

## Serial-interfaced 6-digit LED controller with keyscan

### Features

- LED driver with 14 outputs (8 segments/6 digits)
- 40 mA load current capability for each segment
- Output pins connected directly to the LEDs or can be open-drain
- Key-scanning (8 x 2 matrix)
- Low power consumption in standby mode
- 3-wire serial bus interface (CLK, STB, DIN/DOUT)
- 8-step dimming circuit to control the overall display brightness
- Single external resistor for output current setting
- Inputs with Schmitt trigger give superior noise immunity
- A single LED digit output (DIG1\_LED) can be used to drive up to 8 discrete LEDs
- 8-step dimming circuit to control brightness of individual LEDs for LED digit
- 5.0 V ( $\pm 10\%$ ) for  $V_{CC}$
- Drives common-anode LED digits
- Built-in power on reset and soft-start circuits
- Available in SO24 package
- $-40\text{ }^{\circ}\text{C}$  to  $85\text{ }^{\circ}\text{C}$  operating temperature range

### Applications

- Set-top-boxes
- White goods
- Home appliances
- DVD players and VCRs

**Table 1. Device summary**

| Part number  | Package | Packaging     |
|--------------|---------|---------------|
| STLED316SMTR | SO-24   | Tape and reel |

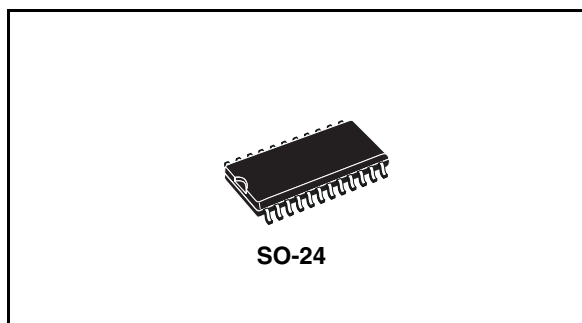

### Description

The STLED316S is a compact LED controller and driver that interface microprocessors to LED displays through a serial 3-wire interface. It drives LED connected in common anode configuration. The STLED316S drives up to 48 discrete LEDs in 8 segment/6 digit configuration while functioning from a supply voltage of 5.0V. Additionally it can be used to drive 8 discrete LEDs which form a part of LED digit. The individual LEDs are wired as segments of a digit and brightness of these individual LEDs can be controlled digitally. The maximum segment current for the display digits is set through a single external resistor. Individual digits may be addressed and updated without re-writing the entire display.

Additionally it includes key scanning for an 8x2 key matrix which automatically scans a matrix of up to 16 switches. STLED316S supports numeric-type displays and reduces the overall BOM costs through high integration. Also it provides ESD protection of greater than 4 kV HBM.

The LED controller/driver is ideal as a peripheral device to interface the display with a singlechip microcomputer.

# Contents

|          |   |           |
|----------|---|-----------|
| <b>1</b> | <b>STLED316S functional and application diagram</b> | <b>3</b>  |
| <b>2</b> | <b>Pin description</b>                              | <b>5</b>  |
| <b>3</b> | <b>STLED316S functional description</b>             | <b>7</b>  |
| 3.1      | Low power mode of operation                         | 7         |
| 3.2      | Serial interface                                    | 7         |
| 3.3      | Initial power up                                    | 7         |
| 3.4      | Display types                                       | 8         |
| 3.5      | Keyscan   | 8         |
| 3.6      | Discrete LED outputs                                | 8         |
| 3.7      | Power on reset and soft-start                       | 8         |
| 3.8      | LED drivers   | 9         |
| 3.9      | Interrupt   | 9         |
| 3.10     | Operating the device with 3.3 V interface voltages  | 9         |
| <b>4</b> | <b>Maximum rating</b>                               | <b>10</b> |
| 4.1      | Thermal data  | 10        |
| <b>5</b> | <b>Recommended operating conditions</b>             | <b>11</b> |
| 5.1      | DC electrical characteristics                       | 11        |
| 5.2      | Power consumption estimation                        | 12        |
| 5.3      | Capacitance   | 12        |
| 5.4      | Power supply characteristics                        | 12        |
| 5.5      | Dynamic switching characteristics                   | 13        |
| 5.6      | Timing characteristics                              | 13        |
| 5.7      | ESD performance                                     | 13        |
| <b>6</b> | <b>Key-scan &amp; display cycle</b>                 | <b>14</b> |
| <b>7</b> | <b>Key matrix and key-input data storage ram</b>    | <b>15</b> |
| <b>8</b> | <b>Commands</b>                                     | <b>16</b> |

---

|           |   |           |
|-----------|---|-----------|
| 8.1       | Write command .....                                     | 16        |
| 8.2       | Read command .....                                      | 17        |
| 8.3       | Device configuration .....                              | 18        |
|           | 8.3.1 Display setting (maximum number of digits): ..... | 19        |
|           | 8.3.2 Dimming setting (brightness levels): .....        | 19        |
| 8.4       | Display memory .....                                    | 20        |
| <b>9</b>  | <b>Key-scanning and display timing .....</b>            | <b>22</b> |
|           | 9.1 Serial communication format (reception) .....       | 23        |
|           | 9.2 Serial communication format (transmission) .....    | 24        |
| <b>10</b> | <b>Switching characteristics waveform .....</b>         | <b>25</b> |
| <b>11</b> | <b>Application information .....</b>                    | <b>26</b> |
|           | 11.1 Graph of ISET against RSET .....                   | 26        |
|           | 11.2 Power supply sequencing .....                      | 27        |
|           | 11.3 Application diagram .....                          | 27        |
| <b>12</b> | <b>Package mechanical data .....</b>                    | <b>28</b> |
| <b>13</b> | <b>Revision history .....</b>                           | <b>29</b> |

## List of figures

|            |   |    |
|------------|---|----|
| Figure 1.  | STLED316S functional diagram . . . . .              | 5  |
| Figure 2.  | STLED316S application diagram . . . . .             | 6  |
| Figure 3.  | STLED316S pin connection . . . . .                  | 7  |
| Figure 4.  | Key matrix. . . . .                                 | 17 |
| Figure 5.  | Serial communication format (reception) . . . . .   | 25 |
| Figure 6.  | Serial communication format (transmission). . . . . | 26 |
| Figure 7.  | Switching characteristics waveform . . . . .        | 27 |
| Figure 8.  | Graph of ISET against RSET . . . . .                | 28 |
| Figure 9.  | STLED316S application diagram . . . . .             | 29 |
| Figure 10. | SO-24 package outline . . . . .                     | 30 |

## List of tables

|           |   |    |
|-----------|---|----|
| Table 1.  | Device summary . . . . .  | 1  |
| Table 2.  | Pin description . . . . .   | 8  |
| Table 3.  | Seven segment display with dot point and common-anode LED panel . . . . .   | 11 |
| Table 4.  | Absolute maximum ratings (all voltages are referenced to GND). . . . .  | 13 |
| Table 5.  | Thermal data. . . . .   | 13 |
| Table 6.  | DC electrical characteristics<br>( $T_A = -40$ to $+85$ °C, $V_{CC} = 5.0$ V $\pm$ 10%, GND = 0 V) . . . . .                                    | 14 |
| Table 7.  | Capacitance ( $T_A = 25$ °C, $f = 1$ MHz) . . . . .   | 15 |
| Table 8.  | Power supply characteristics ( $T_A = -40$ to $+85$ °C). . . . .  | 15 |
| Table 9.  | Dynamic switching characteristics<br>( $T_A = -40$ to $+85$ °C, $V_{CC} = 5.0$ V $\pm$ 10%, GND = 0.0 V, typical values are at 25 °C) . . . . . | 16 |
| Table 10. | Timing characteristics<br>( $T_A = -40$ to $+85$ °C, $V_{CC} = 5.0$ V $\pm$ 10%, GND = 0.0 V, Typical values are at 25 °C) . . . . .            | 16 |
| Table 11. | ESD performance . . . . .   | 16 |
| Table 12. | Read command . . . . .  | 20 |
| Table 13. | Memory page mapping . . . . .   | 21 |
| Table 14. | Digit address mapping . . . . .   | 21 |
| Table 15. | LED address mapping . . . . .   | 22 |
| Table 16. | Memory page address . . . . .   | 23 |
| Table 17. | 7-segment display address. . . . .  | 23 |
| Table 18. | LED display address. . . . .  | 23 |
| Table 19. | Part list . . . . .   | 30 |
| Table 20. | SO-24 package mechanical data . . . . .   | 31 |
| Table 21. | Document revision history . . . . .   | 32 |

# 1 STLED316S functional and application diagram

The STLED 316S consists of the following blocks:

- Current source
- POR and soft-start
- Interrupt generator
- Serial interface
- Digital logic blocks
- Drivers

**Figure 1. STLED316S functional diagram**

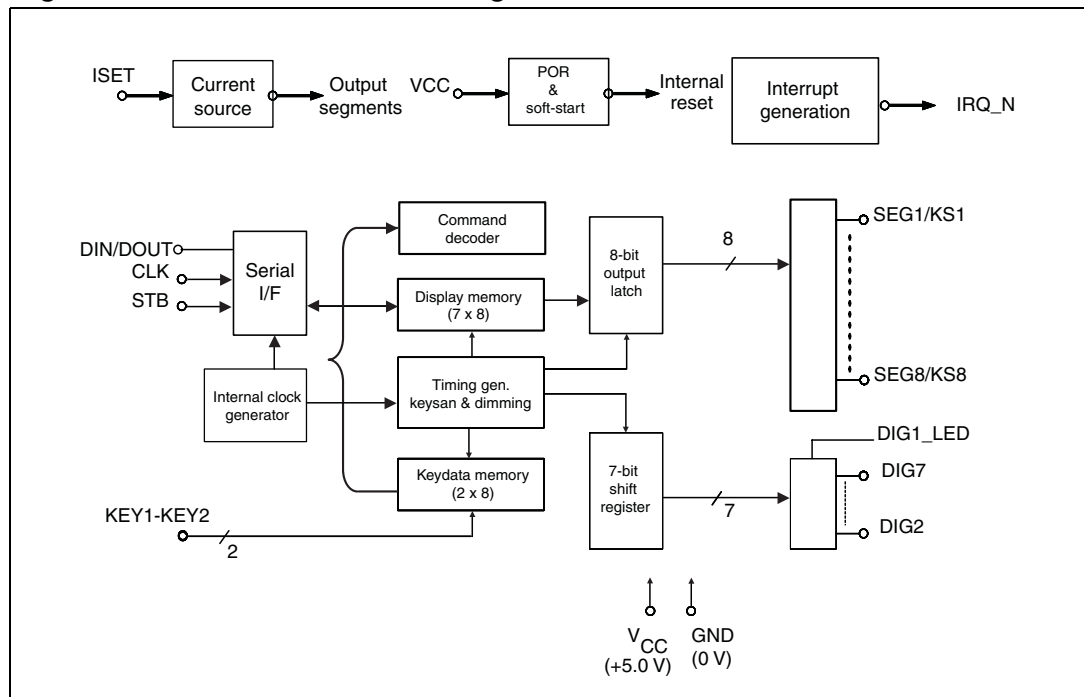
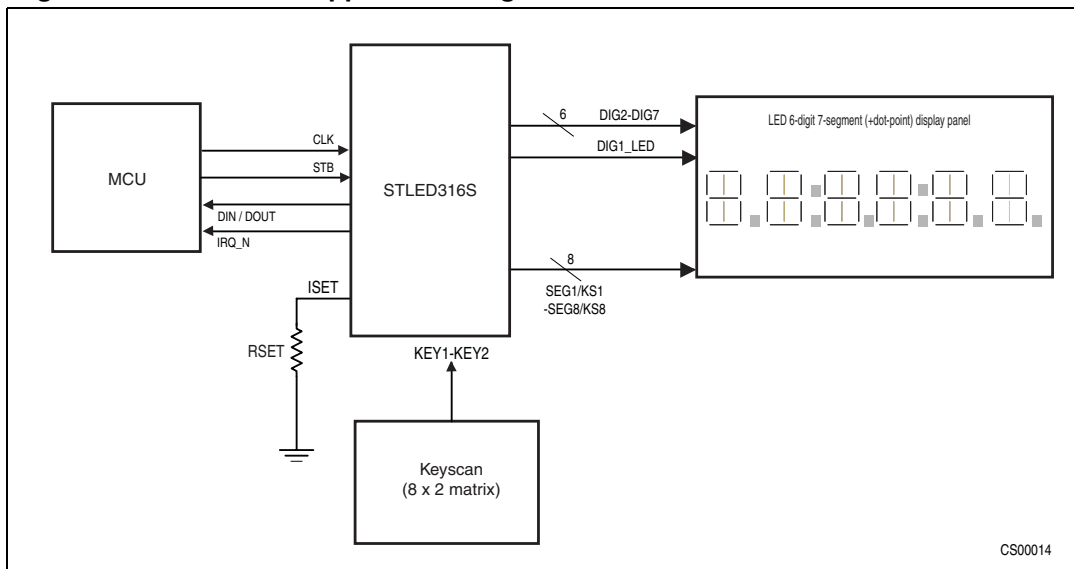

Figure 2. STLED316S application diagram



## 2 Pin description

Figure 3. STLED316S pin connection

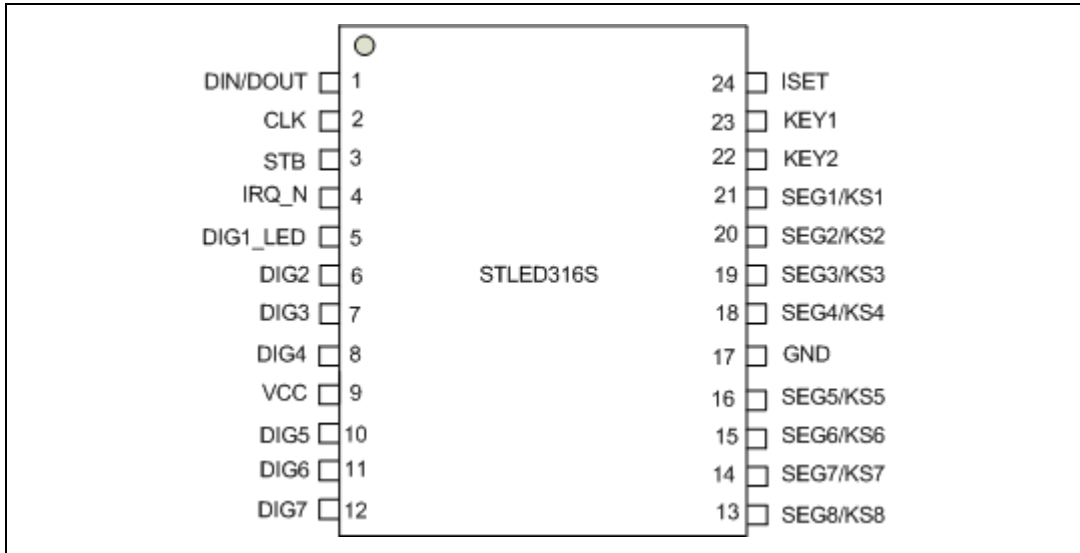

Table 2. Pin description

| Pin number | Symbol           | Type   | Name and function   |
|------------|------------------|--------|---|
| 1          | DIN/DOUT         | IN/OUT | Output serial data at falling edge of the shift clock, starting from lower bit. Input serial data is clocked in at rising edge of the shift clock, starting from lower bit.   |
| 2          | CLK              | IN     | Reads serial data at rising edge, and outputs data at falling edge.   |
| 3          | STB              | IN     | Initializes serial interface at rising or falling edge to make STLED316S wait for reception of command. Data input after the falling edge of STB are processed as a command. While command data are processed, current processing is stopped, and the serial interface is initialized. While STB is high, instructions are ignored. |
| 4          | IRQ_N            | OUT    | Interrupt output (active low) to interrupt the MCU when there is a key press  |
| 5          | DIG1_LED         | OUT    | Single output LED used together with the 8 segments to drive up to 8 discrete LEDs  |
| 6,7,8      | DIG2, DIG3, DIG4 | OUT    | Digit output pins.  |
| 9          | V <sub>CC</sub>  | PWR    | 5.0 V ± 10% Core main supply voltage. Bypass to GND through a 0.1 μF capacitor as close to the pin as possible.   |
| 10,11,12   | DIG5, DIG6, DIG7 | OUT    | Digit output pins.  |



**Table 2. Pin description (continued)**

| Pin number  | Symbol                     | Type | Name and function  |
|-------------|----------------------------|------|--|
| 13,14,15,16 | SEG8/KS8<br>to<br>SEG5/KS5 | OUT  | Segment output pins (dual function as key source).   |
| 17          | GND                        | PWR  | Connect this pin to system GND.  |
| 18,19,20,21 | SEG4/KS4<br>to<br>SEG1/KS1 | OUT  | Segment output pins (dual function as key source).   |
| 22          | KEY2                       | IN   | Key 2 input. Input data to these pins from external keyboard are latched at end of the display cycle (maximum keyboard size is 8 x 2). |
| 23          | KEY1                       | IN   | Key 1 input. Input data to these pins from external keyboard are latched at end of the display cycle (maximum keyboard size is 8 x 2). |
| 24          | ISET                       | IN   | Segment current setting. Connect to GND through a resistor to set the peak segment current.  |

## 3 STLED316S functional description

The STLED316S is a common-anode LED driver controller which can be used to drive red, green or blue LEDs as the current is adjustable through the external resistor. In the common anode configuration, the segment outputs sink the current from the cathodes while the digit outputs source the current to the anodes. The configurable output current can be used to drive LEDs with different current ratings (red, green or blue). The brightness of the whole display can be controlled through the serial interface as described later. The outputs can be connected together in parallel to drive a single LED. In this case, two parallel current sources of equal value drive a single LED. The external resistor value can be set accordingly to determine the desired output current thus controlling the display brightness.

Soft-start limits the inrush current during power-up. The display is blanked (LEDs are turned off or in high-Z state) on power-up.

### 3.1 Low power mode of operation

Upon initial power up or when not configured or when not used, the STLED316S will be in low power mode of operation wherein the current consumption drops to less than 1mA. During this mode, the data configured is maintained as long as the supply voltage is still present (the contents of the internal RAM need the supply voltage to be present). Port configuration and output levels are restored when the STLED316S resumes normal operation. For minimum supply current in shutdown mode, logic inputs should be at GND or  $V_{CC}$ .

### 3.2 Serial interface

The interface is used to write configuration and display data to the STLED316S. The serial interface comprises of a shift register into which DIN is clocked on the rising edge of the CLK when STB is low. When STB is low, falling transitions on CLK clock the data from the device to the microcontroller. The 8-bit data is decoded to determine and execute the command.

STB indicates to the device the start of communication when it goes low. DIN/DOUT pin is bi-directional. The data will be validated during positive pulse of the clock in both write/read modes. If the STB signal goes high before completing the data byte write to the device, the preceding data bits are ignored and the previous configuration remains intact.

### 3.3 Initial power up

On initial power-up, all control registers are reset, the display is blanked and the STLED316S is in the low power mode. All the outputs are in high-impedance state at initial power-up. The DIN/DOUT is pulled high by an external pull-up resistor. The display driver has to be configured before the display can be used.

### 3.4 Display types

Table 3. Seven segment display with dot point and common-anode LED panel

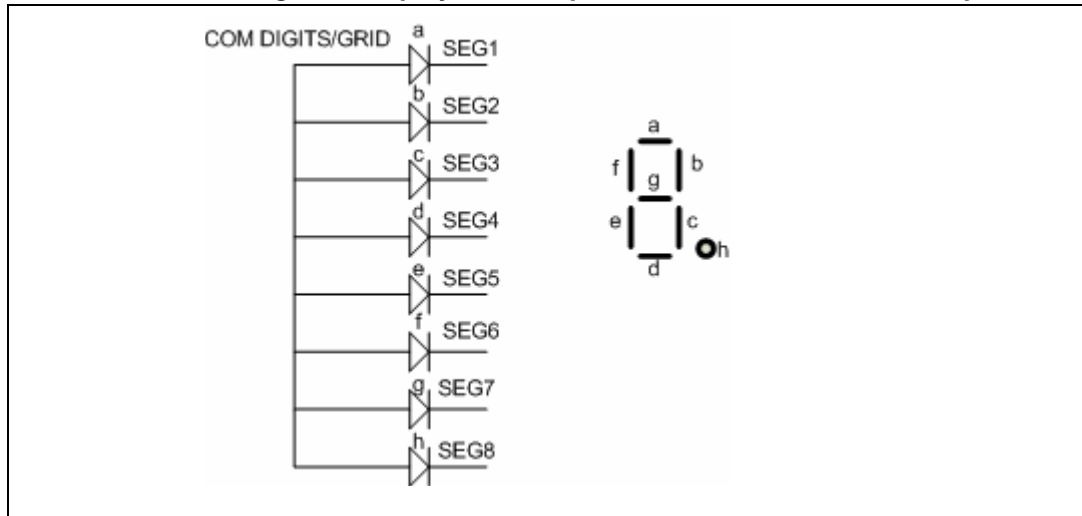

### 3.5 Keyscan

The full keyscan is illustrated in the another section of the datasheet. One diode is required per key switch. The keyscan circuit detects any combination of keys being pressed.

### 3.6 Discrete LED outputs

The STLED316S can be used to drive up to 8 discrete LEDs. The single LED output acts like a digit driver output and can be wired-up with 8 segment outputs to drive up to 8 different discrete LEDs. Physical connections from the LED output as well as the segment outputs must be made to drive the discrete LEDs in the desired manner. The discrete LEDs may be needed to indicate the “Power”, “Standby” status (for example). Also it is possible to separately control the brightness of each single LED.

### 3.7 Power on reset and soft-start

The device integrates an internal power-on-reset circuit which initializes the digital logic upon power up. The soft-start circuit limits the inrush current and high peak current during power-up. This is done by delaying the input circuit’s response to the external applied voltage. During soft-start, the input resistance is higher which lowers the in-rush current when the supply voltage is applied.

### 3.8 LED drivers

The constant current capability is up to 40 mA per output segment and is set for all the outputs using a single external resistor. When acting as digit drivers, the outputs source current to the display anodes. When acting as segment drivers, the LED outputs sink current from the display cathodes. The outputs are high impedance when not being used as digit or segment drivers.

Each port configured as a LED digit driver behaves as a digitally-controlled constant current sink. The LED drivers are suitable for both discrete LEDs and common anode (CA) numeric LED digits. When fully configured as a LED driver, the STLED316S controls up to 8 LED segments in a single digit with 8-step logarithmic brightness control for the digits. A single resistor sets the maximum segment current for all the segments, with a maximum of 40mA per segment. The STLED316S drives any combination of discrete LEDs and CA digits for numeric displays.

The recommended value of  $R_{SET}$  is the minimum allowed value, since it sets the display driver to the maximum allowed segment current.  $R_{SET}$  can be a higher value to set the segment current to a lower maximum value where desired. The user must also ensure that the maximum current specifications of the LEDs connected to the drivers are not exceeded.

The brightness of the individual digits in the display panel can be controlled separately.

### 3.9 Interrupt

The device includes an active low level  $IRQ\_N$  pin to the microprocessor. The STLED316S generates an interrupt when a key is pressed.

### 3.10 Operating the device with 3.3 V interface voltages

The device can detect the input voltage levels reference to 3.3 V from the main controller chip as long as the  $V_{IL}$  and  $V_{IH}$  specifications of the STLED316S are met. If the input voltage to STLED316S is greater than 2.9 V, the STLED316S will recognize the signal level as a valid high and if the input voltage is lower than 1.75 V, it will be recognized as a valid low level.

For the output signals from the device like  $DOUT$  and  $IRQ\_N$ , the signal level depends on the external supply to which the external pull up resistor is connected to. Thus this eliminates the use of any level shifter between the main controller and the STLED316S.

## 4 Maximum rating

Stressing the device above the rating listed in the “Absolute maximum ratings” table may cause permanent damage to the device. These are stress ratings only and operation of the device at these or any other conditions above those indicated in the operating sections of this specification is not implied. Exposure to absolute maximum rating conditions for extended periods may affect device reliability. Refer also to the STMicroelectronics SURE program and other relevant quality documents.

**Table 4. Absolute maximum ratings** (all voltages are referenced to GND)

| Symbol    | Parameters   | Values               | Unit |
|-----------|--|----------------------|------|
| $V_{CC}$  | Supply voltage to ground   | -0.5 to +7.0         | V    |
| $V_I$     | Logic input voltage  | -0.5 to $V_{CC}+0.5$ | V    |
| $P_D$     | Power dissipation <sup>(1)</sup>   | 1200                 | mW   |
| $T_A$     | Operating ambient temperature  | -40 to 85            | °C   |
| $T_J$     | Junction temperature   | 150                  | °C   |
| $T_{STG}$ | Storage temperature  | -65 to +150          | °C   |
| $T_L$     | Lead temperature (10 sec)  | 300                  | °C   |
| $V_{ESD}$ | Electrostatic discharge voltage on all pins <sup>(2)</sup><br>Human body model | -4 to +4             | kV   |

1. De-rate at -9.6 mW/°C at  $T_A = 25^\circ\text{C}$  or higher

2. In accordance with the JEDEC standard

### 4.1 Thermal data

**Table 5. Thermal data**

| Symbol     | Parameter                           | Min | Typ | Max | Unit |
|------------|-------------------------------------|-----|-----|-----|------|
| $T_{thJC}$ | Thermal resistance junction-ambient |     | 75  |     | °C/W |

## 5 Recommended operating conditions

### 5.1 DC electrical characteristics

**Table 6. DC electrical characteristics**  
( $T_A = -40$  to  $+85$  °C,  $V_{CC} = 5.0$  V  $\pm$  10%, GND = 0 V)

| Symbol              | Parameter  | Test conditions                                      | Min           | Typ  | Max          | Unit     |
|---------------------|--|--|---------------|------|--------------|----------|
| $V_{CC}$            | Logic supply voltage   |  | 4.5           | 5.0  | 5.5          | V        |
| $V_{IH}$            | High level input voltage   | High level guaranteed digital pins                   | 0.57 $V_{CC}$ |      | $V_{CC}$     | V        |
| $V_{IL}$            | Low level input voltage  | Low level guaranteed digital pins                    | 0             |      | 0.3 $V_{CC}$ | V        |
| $I_{IH}$ , $I_{IL}$ | Input current  | $V_{IN} = V_{CC}$ or GND                             | -2            |      | 2            | $\mu$ A  |
| $V_{HYS}$           | Hysteresis voltage (DIN, CLK, STB pins)                                      |  | 0.9           | 1.05 | 1.2          | V        |
| $V_{OL(DOUT)}$      | Low level output voltage   | DOUT, $I_{OL2} = 4$ mA                               |               |      | 0.4          | V        |
| $I_{OLEAK}$         | Driver leakage current   | Drivers off  |               |      | -140         | $\mu$ A  |
| $I_{SEG}$           | Segment drive LED sink current   | $V_{LED} = 2.5$ V<br>$V_{DIGIT} = V_{CC} - 1.0$      | -30           | -40  | -50          | mA       |
| $I_{DIG}$           | Digit drive LED source current   | $V_{DIGIT} = V_{CC} - 1.0$                           | 240           | 320  | 400          | mA       |
| $I_{TOLSEG}$        | Segment drive current matching   | $V_{CC} = 5.0$ V, $T_A = 25$ °C<br>$V_{LED} = 2.5$ V |               | 3    |              | %        |
| $R_{SET}$           | External current setting reference resistor (precision = $\pm$ 1% tolerance) | $I_{SEG} = 40$ mA                                    |               | 360  |              | $\Omega$ |

## 5.2 Power consumption estimation

Each port of the STLED316S can sink a maximum current of 40 mA into an LED with a 4.4 V forward voltage drop when operated from a supply voltage of 5.0 V. The minimum voltage drop across the internal LED drivers is thus 5.0 - 4.4 = 0.6 V. The STLED316S can sink  $8 \times 40 = 320$  mA when all outputs are operating as LED segment drivers at full current. On a 5.0 V supply, a STLED316S dissipates  $(5.0 \text{ V} - 4.4 \text{ V}) \times 320 \text{ mA} = 192 \text{ mW}$  when driving 8 of these 4.4 V forward voltage drop LEDs at full current. If the application requires high drive current, consider adding a series resistor to each LED to drop excessive drive voltage off-chip.

If the forward voltage of the LED is lesser than 4.4 V (say 2.4 V), then the maximum power dissipation of STLED316S when all segments are turned on will be  $(5 - 2.4) \text{ V} \times 320 \text{ mA} = 832 \text{ mW}$ . To lower the power dissipation, consider adding a small series resistor in the supply. Another alternative is to increase the value of the  $R_{SET}$  to lower the current of the LEDs from 40 mA to say 30 or 20 mA.

The efficiency will be the power consumption in the LEDs divided by the input power consumed.

$$\text{Efficiency} = V_{\text{diode}} \times I_{\text{diode}} / V_{\text{CC}} \times I_{\text{CC}}$$

As an example, consider LED with forward voltage of  $V_F = 2.4 \text{ V}$ ,  $I_{\text{peak}} = 40 \text{ mA}$ ,  $V_{\text{CC (max)}} = 5.5 \text{ V}$ ,  $N = \text{number of segments} = 8 \text{ (max)}$ ,  $D = \text{duty cycle} = 15/16$ ,

Power dissipation,  $P_{D \text{ (max)}} = 5 \text{ mA} \times 5.5 \text{ V} + (5.5 - 2.4) \text{ V} \times (15/16) \times 40 \text{ mA} \times 8 = 27.5 + 780 = 807.5 \text{ mW}$ . To lower this value, add a series resistor with the supply.

## 5.3 Capacitance

**Table 7. Capacitance** ( $T_A = 25 \text{ }^\circ\text{C}$ ,  $f = 1 \text{ MHz}$ )

| Symbol   | Parameter         | Test conditions | Min | Typ | Max | Unit |
|----------|-------------------|-----------------|-----|-----|-----|------|
| $C_{IN}$ | Input capacitance |                 |     |     | 15  | pF   |

## 5.4 Power supply characteristics

**Table 8. Power supply characteristics** ( $T_A = -40 \text{ to } +85 \text{ }^\circ\text{C}$ )

| Symbol            | Parameter                                   | Test conditions  | Min. | Typ. | Max. | Unit          |
|-------------------|---|--|------|------|------|---------------|
| $I_{\text{STBY}}$ | Quiescent power supply current              | $V_{\text{CC}} = 5.5 \text{ V}$ ,<br>All inputs = $V_{\text{CC}}$ or GND                                   |      | 50   | 1000 | $\mu\text{A}$ |
| $I_{\text{CC}}$   | Operating power supply current (display ON) | All segments ON, all digits scanned, intensity set to full, internal oscillator, no display load connected |      | 10   | 15   | mA            |

## 5.5 Dynamic switching characteristics

**Table 9. Dynamic switching characteristics**

( $T_A = -40$  to  $+85$  °C,  $V_{CC} = 5.0$  V  $\pm$  10%, GND = 0.0 V, typical values are at 25 °C)

| Symbol    | Parameter                      | Test conditions                                      | Min. | Typ. | Max. | Unit |
|-----------|--------------------------------|--|------|------|------|------|
| $f_{OSC}$ | Internal oscillation frequency |  | 400  | 500  | 600  | kHz  |
| $f_{MAX}$ | Clock (CLK) frequency          | Duty = 50%   | 1    |      |      | MHz  |
| $t_{PLZ}$ | Propagation delay              | CLK to DOUT<br>$R_L = 10$ K $\Omega$ , $C_L = 15$ pF |      |      | 300  | ns   |
| $t_{PZL}$ |                                |  |      |      | 100  | ns   |

## 5.6 Timing characteristics

**Table 10. Timing characteristics**

( $T_A = -40$  to  $+85$  °C,  $V_{CC} = 5.0$  V  $\pm$  10%, GND = 0.0 V, Typical values are at 25 °C)

| Symbol        | Parameter          | Test conditions                    | Min. | Typ. | Max. | Unit    |
|---------------|--------------------|------------------------------------|------|------|------|---------|
| $PW_{CLK}$    | Clock pulse width  |                                    | 400  |      |      | ns      |
| $PW_{STB}$    | Strobe pulse width |                                    | 1    |      |      | $\mu$ s |
| $t_{SETUP}$   | Data setup time    |                                    | 100  |      |      | ns      |
| $t_{HOLD}$    | Data hold time     |                                    | 100  |      |      | ns      |
| $t_{CLK-STB}$ | Clock-strobe time  | CLK rising edge to STB rising edge | 1    |      |      | $\mu$ s |

## 5.7 ESD performance

**Table 11. ESD performance**

| Symbol | Parameter                 | Test conditions | Min. | Typ.    | Max. | Unit |
|--------|---------------------------|-----------------|------|---------|------|------|
| ESD    | JEDEC standard (all pins) | HBM             |      | $\pm 4$ |      | kV   |



## 6 Key-scan & display cycle

The display RAM stores the data transmitted from an external device to the STLED316S through the serial interface. Refer to [Section 9: Key-scanning and display timing on page 25](#) for a pictorial representation.

The grid and segment outputs are controlled by the display output module. The entire grid will be turned off on channel 1/16 and 16/16 meaning that the first channel and last channel are off. This is referred to as blanking time.

During the keyscan time (first cycle from timing generator), the entire grid is turned off and only the segments are enabled one by one (seg0 to seg7). The segment on time is 64  $\mu$ s.

During the LED discrete time (second cycle), the data present on the internal LED buffer is checked. If the data is present, then the brightness setting of each LED in the brightness control register is checked. Then each segment will be enabled or disabled based on the register value. In this duration, the grids 1 to 6 are turned off. The grid corresponding to LED digit is turned on. The LED on duty cycle is 14/16. If the LED/seg1 brightness is 12/16, it means that the segment1 OFF time is 12/16 and on time is 2/16.

During 7-segment display time (3<sup>rd</sup> cycle to 8<sup>th</sup> cycle), the display status is checked whether it is ON or OFF. If display is ON, then the dimming settings are checked from the configuration register for the grid (it may be common dimming setting or individual dimming setting for each digit). The minimum turn on time is 1/16 and maximum turn on time is 14/16. The blanking time is valid before the turning on and turning off of the grid. The blanking interval is 32  $\mu$ s. This will continue until the maximum number of digits configured in the register. Once the full cycle is complete, the keyscan cycle will start again.

If the display is not turned on, then the timing generation will immediately go to the key scan mode.

### **Initial:**

All the segments and grids are turned off.

### **During operation:**

1. Turn on segment (keyscan) one by one. On time duration is 64  $\mu$ s.
2. Check the data present in LED register. If data is present, turn on the respective LED grid and segments.
3. Check the display on. If display is turned on, then enable the grid one by one from grid 1 to grid 6 (maximum) and turn on segments.

## 7 Key matrix and key-input data storage ram

During the key scan cycle all the grids are turned off. The first segments turn on is 64  $\mu$ s. The key1 and key2 signals will be sampled after 60  $\mu$ s. The two signals latch into the internal key buffer. The same applies for other segments.

This key buffer compares the data with the previous key status. If any changes are seen in the buffer values, then the IRQ\_N is asserted. The IRQ\_N signal is active low (level). This IRQ\_N signal will be cleared at the end of reading the key buffer (end of byte transfer). The key buffer must be completely read before the IRQ\_N is cleared.

The key matrix is of 8 x 2 configuration, as shown below:

**Figure 4. Key matrix**

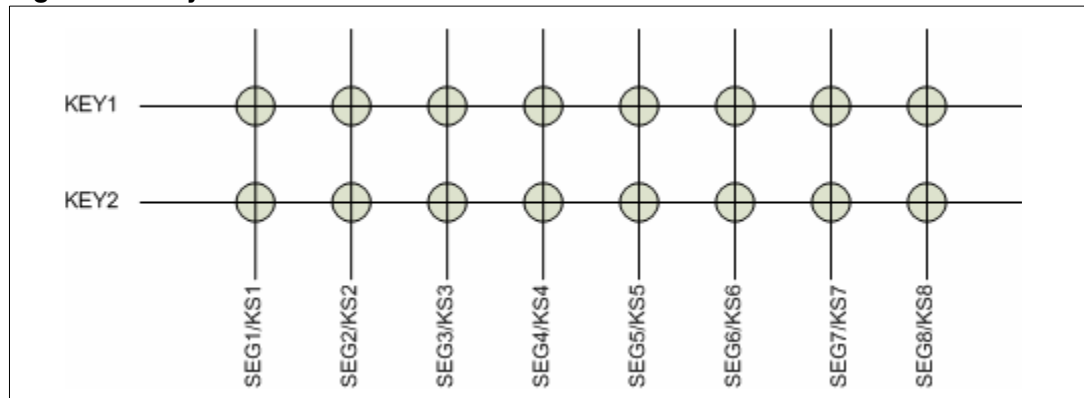

The data of each key are stored as illustrated below, and are read by the appropriate read command, starting from the least significant bit.

### 1<sup>st</sup> byte

|          |          |          |          |          |          |          |          |
|----------|----------|----------|----------|----------|----------|----------|----------|
| KEY1     | KEY1     | KEY1     | KEY1     | KEY1     | KEY1     | KEY1     | KEY1     |
| SEG1/KS1 | SEG2/KS2 | SEG3/KS3 | SEG4/KS4 | SEG5/KS5 | SEG6/KS6 | SEG7/KS7 | SEG8/KS8 |

LSB MSB

### 2<sup>nd</sup> byte

|          |          |          |          |          |          |          |          |
|----------|----------|----------|----------|----------|----------|----------|----------|
| KEY2     | KEY2     | KEY2     | KEY2     | KEY2     | KEY2     | KEY2     | KEY2     |
| SEG1/KS1 | SEG2/KS2 | SEG3/KS3 | SEG4/KS4 | SEG5/KS5 | SEG6/KS6 | SEG7/KS7 | SEG8/KS8 |

LSB MSB

The initial key buffer value is “00”. During operation, the buffer values will change depending upon the values of the key-press.

## 8 Commands

Command sets the display mode and the status of the LED driver. The first byte input to the STLED316S through the DIN input after the STB goes low is regarded as a command. If STB is set high while commands/data are transmitted, serial communication is initialized, and the commands/data being transmitted are invalid (however, the commands/data already transmitted remain valid).

### 8.1 Write command

| MSB 8 | MSB 7 | MSB6 | MSB5 | LSB4 | LSB3 | LSB2 | LSB1 |
|-------|-------|------|------|------|------|------|------|
|-------|-------|------|------|------|------|------|------|

**Description:**

- LSB 3 -1 →address of the memory
- MSB5 and LSB4 →address of memory bank (page)
- MSB →6 '0' auto increment address
  - '1' fixed address
- MSB 7 →0' Write command
  - '1' Read command
- MSB 8 →X' Unused

The following bytes are either configuration data or display data.

During the write command, the control flag display on and auto increment address are latched into the internal control flag register. The default value is '0' for display on control register implying that the display is off. The user must turn on the display to view the display memory. Similarly the auto increment address mode is enabled by default. If the user desires to read from a particular address location, the user can fix the address pointer.

#### Display on:

| MSB 8 | MSB 7 | MSB6 | MSB5 | LSB4 | LSB3 | LSB2 | LSB1 |
|-------|-------|------|------|------|------|------|------|
| x     | 0     | X    | 0    | 1    | 1    | 0    | 1    |

#### Display off:

| MSB 8 | MSB 7 | MSB6 | MSB5 | LSB4 | LSB3 | LSB2 | LSB1 |
|-------|-------|------|------|------|------|------|------|
| x     | 0     | X    | 0    | 1    | 1    | 1    | 0    |

Use these two commands to turn the display 'ON' and 'OFF'.

## 8.2 Read command

|       |       |      |      |      |      |      |      |
|-------|-------|------|------|------|------|------|------|
| MSB 8 | MSB 7 | MSB6 | MSB5 | LSB4 | LSB3 | LSB2 | LSB1 |
|-------|-------|------|------|------|------|------|------|

- Description:**
- LSB 3 -1 →address of the memory
  - MSB5 and LSB4 →address of the memory bank (page)
  - MSB 6 →'0' auto increment address  
'1' fixed address
  - MSB 7 →'0' Write command  
'1' Read command
  - MSB 8 →'X' Unused

Use the page 0x01 to read the LED data and key data.

**Table 12. Read command**

| Address | Function            |
|---------|---------------------|
| 00      | LED data (optional) |
| 01      | Key data byte1      |
| 02      | Key data byte2      |

Set flag for key1 and key2 to ensure that the user reads from the particular key. When reading the key data from the memory, the IRQ\_N will be automatically cleared signifying that the end of the 8<sup>th</sup> bit was transmitted correctly.

If the IRQ\_N is asserted by the last eight keys, then the user reads the key data (one byte only by reading the first byte). In this case, the IRQ\_N will remain active until the second byte is read. When the user uses the read key to read the LED and key data, first the user must choose the address (default address location is 0x00) after which the address will increment only by 3 addresses (maximum).

## 8.3 Device configuration

This section describes how to program and read the configuration of the device. Configuration data comprises of the display setting, dimming setting, display on/off and fixed

address/auto increment. The address pointer will indicate the configuration location and write signal writes the configuration data into the respective location.

The memory block is split into two page locations. One is for the 7-segment brightness configuration memory and the other is for the LED (discrete) configuration memory. The configuration memory address starts from 0x00 to 0x07. The configuration page address is "10" and "11".

**Initial Value:**

**Table 13. Memory page mapping**

| Memory page | Address | Value |
|-------------|---------|-------|
| 10          | 00      | 0xFB  |
| 10          | 01      | 0x00  |
| 10          | 02      | 0x00  |
| 10          | 03      | 0x00  |
| 11          | 00      | 0x00  |
| 11          | 01      | 0x00  |
| 11          | 02      | 0x00  |
| 11          | 03      | 0x00  |

**Description:** Address 0x00; page 0x10  
 LSB 0 – 2 → indicates the number of digits in the display  
 LSB3 MSB 4 → '11' is for constant brightness control for the display  
                   → '00' is for variable brightness control for the display  
                   → '01' is reserved  
                   → '10' is reserved  
 MSB 5 – 7 → indicates constant brightness control value for all including the LED (discrete)

Default is constant brightness control with 14/16 pulse width (for maximum brightness).

Page 0x10 - address 0x01 to 0x03 is for the variable brightness control value for 7 segments:

**Table 14. Digit address mapping**

| Address | MSB     | LSB     |
|---------|---------|---------|
| 0x01    | Digit 2 | Digit 1 |
| 0x02    | Digit 4 | Digit 3 |
| 0x03    | Digit 6 | Digit 5 |

Default is constant brightness control with 14/16 pulse width.

Page 0x11 - address 0x00 to 0x03 is for the variable brightness control value for LED (discrete)

**Table 15. LED address mapping**

| Address | MSB        | LSB        |
|---------|------------|------------|
| 0x00    | LED/ Seg 2 | LED/ Seg 1 |
| 0x01    | LED/ Seg 4 | LED/ Seg 3 |
| 0x02    | LED/ Seg 6 | LED/ Seg 5 |
| 0x03    | LED/ Seg 8 | LED/ Seg 7 |

Default is constant brightness control with 14/16 pulse width.

During normal operation, the user defined value will be stored in the respective location.

**8.3.1 Display setting (maximum number of digits):**

The 3-bit values corresponding to selection of number of digits of display are shown below:

- 000: 1 digit 8 segments
- 001: 2 digits 8 segments
- 010: 3 digits 8 segments
- 011: 4 digits 8 segments
- 100: 5 digits 8 segments
- 101: 6 digits 8 segments

Select the number of digits by writing the value in page 0x10 and the address 0x00 in LSB2 to LSB0.

**8.3.2 Dimming setting (brightness levels):**

The 4-bit values corresponding to different brightness levels are shown below:

- 0000: pulse width is 1/16
- 0001: pulse width is 2/16
- 0010: pulse width is 4/16
- 0011: pulse width is 10/16
- 0100: pulse width is 11/16
- 0101: pulse width is 12/16
- 0110: pulse width is 13/16
- 0111: pulse width is 14/16

Set the dimming timing (write into respective address location from 0x00 to 0x03; page 0x10 & 0x11).

## 8.4 Display memory

The display memory stores the display data and sends to the LED when the display is on. The address pointer, memory page and write signal indicates to this block the location to write the data. This block will manage the address pointer. When the user writes a first byte, the address increments by one if in auto-increment mode, else the address pointer remains in the same location. The initial address is latched during the write/read command into the address pointer. The display memory (7-segment/LED) is directly mapped into the display segments. The user can access only one bank at a time in both the read and write modes. The memory block is split into 4 pages.

**Table 16. Memory page address**

| Page 1<br>7 segment memory    | Page 2<br>LED Display | Page 3<br>7 segment brightness<br>setting | Page 4<br>LED brightness setting |
|-------------------------------|-----------------------|---|----------------------------------|
| Addr 0x00 to 0x05<br>(40 bit) | Addr 0x00<br>(8 bit)  | Addr 0x00 to 0x03<br>(32bit)              | Addr 0x00 to 0x03<br>(32bit)     |

7-segment display memory page 0x00:

**Table 17. 7-segment display address**

| Address | Data |
|---------|------|
| 0x00    | 0x00 |
| 0x01    | 0x00 |
| 0x02    | 0x00 |
| 0x03    | 0x00 |
| 0x04    | 0x00 |
| 0x05    | 0x00 |

LED display memory page 0x01:

**Table 18. LED display address**

| Address | Data  |
|---------|-------|
| 0x00h   | 0x00h |

### Initial memory:

Default memory value is "00" in all locations.

### During operation:

User defined value in these locations.

When the user wants to read the data from a particular location, the user sends the address page through read command and chooses the mode of the address pointer (fixed or auto). In this case, the user can access the whole memory area in that particular page (maximum 0 x 05).

The display RAM stores the data transmitted from an external device to the STLED316S through the serial interface; addresses are as follows, in 8-bits unit:

| Seg1              | Seg4              | Seg8 |
|-------------------|-------------------|------|
| 00 H <sub>L</sub> | 00 H <sub>U</sub> | DIG2 |
| 01 H <sub>L</sub> | 01 H <sub>U</sub> | DIG3 |
| 02 H <sub>L</sub> | 02 H <sub>U</sub> | DIG4 |
| 03 H <sub>L</sub> | 03 H <sub>U</sub> | DIG5 |
| 04 H <sub>L</sub> | 04 H <sub>U</sub> | DIG6 |
| 05 H <sub>L</sub> | 05 H <sub>U</sub> | DIG7 |

| b0                | b3 | b4                | b7 |
|-------------------|----|-------------------|----|
| XX H <sub>L</sub> |    | XX H <sub>U</sub> |    |

“0” in memory means GND on output; “1” in memory means V<sub>CC</sub> on output.



## 9 Key-scanning and display timing

During the first cycle, the 16 channels are used for the keyscan. The keyscan duration is made up of 64  $\mu$ s. The second cycle is used for the display of the LED (discrete). The maximum time is 512 $\mu$ s and the 3<sup>rd</sup>-8<sup>th</sup> cycles are used for the 7-segment display. The number of cycles will increase or decrease depending upon the user configuration.

By default, the configuration is made up of 4 cycles. If any data is written to the discrete LED, only then the 2<sup>nd</sup> cycle is valid. Otherwise the 7-segment moves from 2<sup>nd</sup>-7<sup>th</sup> cycle. This is a continuous operation. During the normal operation, the user cannot control or stop the timing generation.

One cycle of key scanning consists of one frame, and data of 8 x 2 matrices are stored in the RAM.

### 9.1 Serial communication format (reception)

The figure below shows the “reception” by STLED316S for command/data write sequence. The STB must be low for 1  $\mu$ s before the first and last clock rise. The minimum time the STB must remain low is 9  $\mu$ s.

The maximum clock frequency is 1 MHz with a duty cycle of 50%. Data set-up and hold time must be 100 ns.

**Figure 5. Serial communication format (reception)**

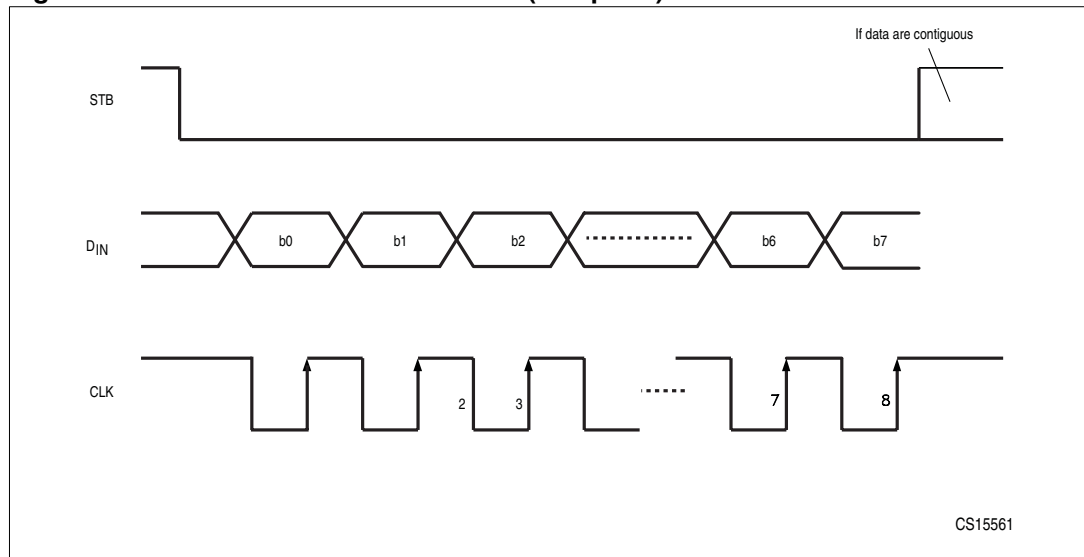

## 9.2 Serial communication format (transmission)

The figure below shows the “transmission” from STLED316S for data read sequence.

**Figure 6. Serial communication format (transmission)**

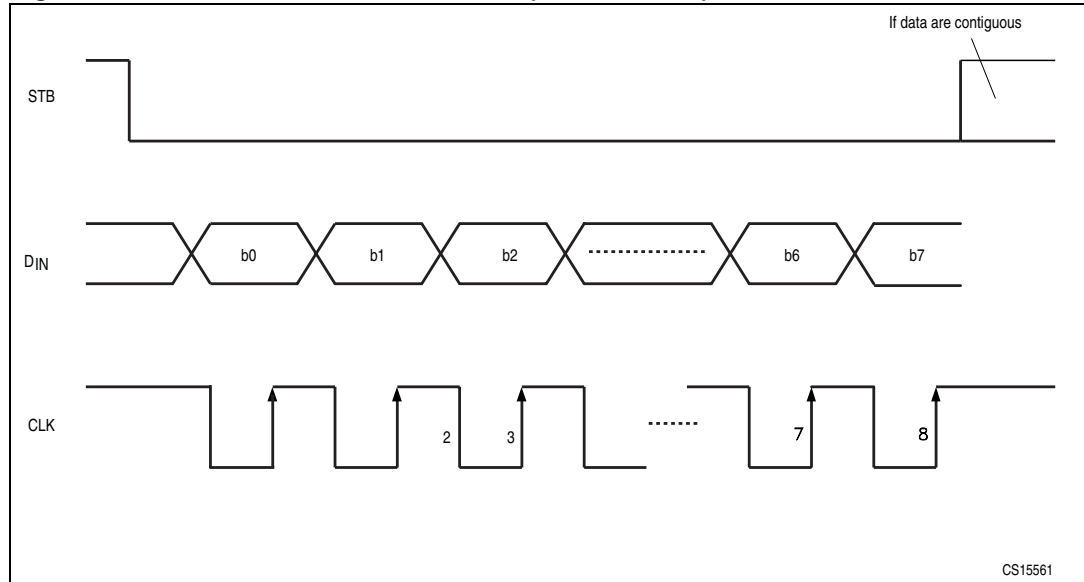

Because the DIN/DOUT pin in a bi-directional pin, it is recommended to connect an external pull-up resistor to this pin (1 KΩ to 10 KΩ).

*Note: No minimum wait time is needed to read the data from the device. The STLED316S will output the data about 250 ns after the 8<sup>th</sup> clock pulse’s falling edge. It is therefore suggested that the host must release the bus within 100ns after clocking the last bit on the 8<sup>th</sup> clock pulse. The STLED316S is able to clock out the valid data on the immediate falling edge of the CLK without missing any clock cycle.*

# 10 Switching characteristics waveform

Figure 7. Switching characteristics waveform

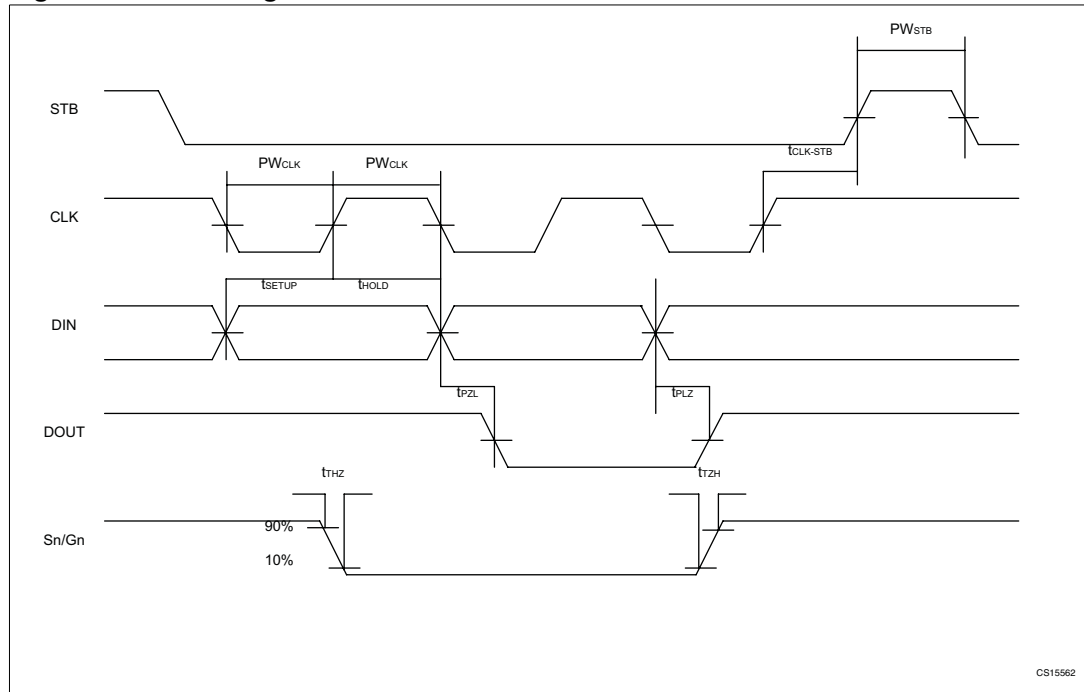

CS15562

# 11 Application information

## 11.1 Graph of ISET against RSET

Figure 8. Graph of ISET against RSET

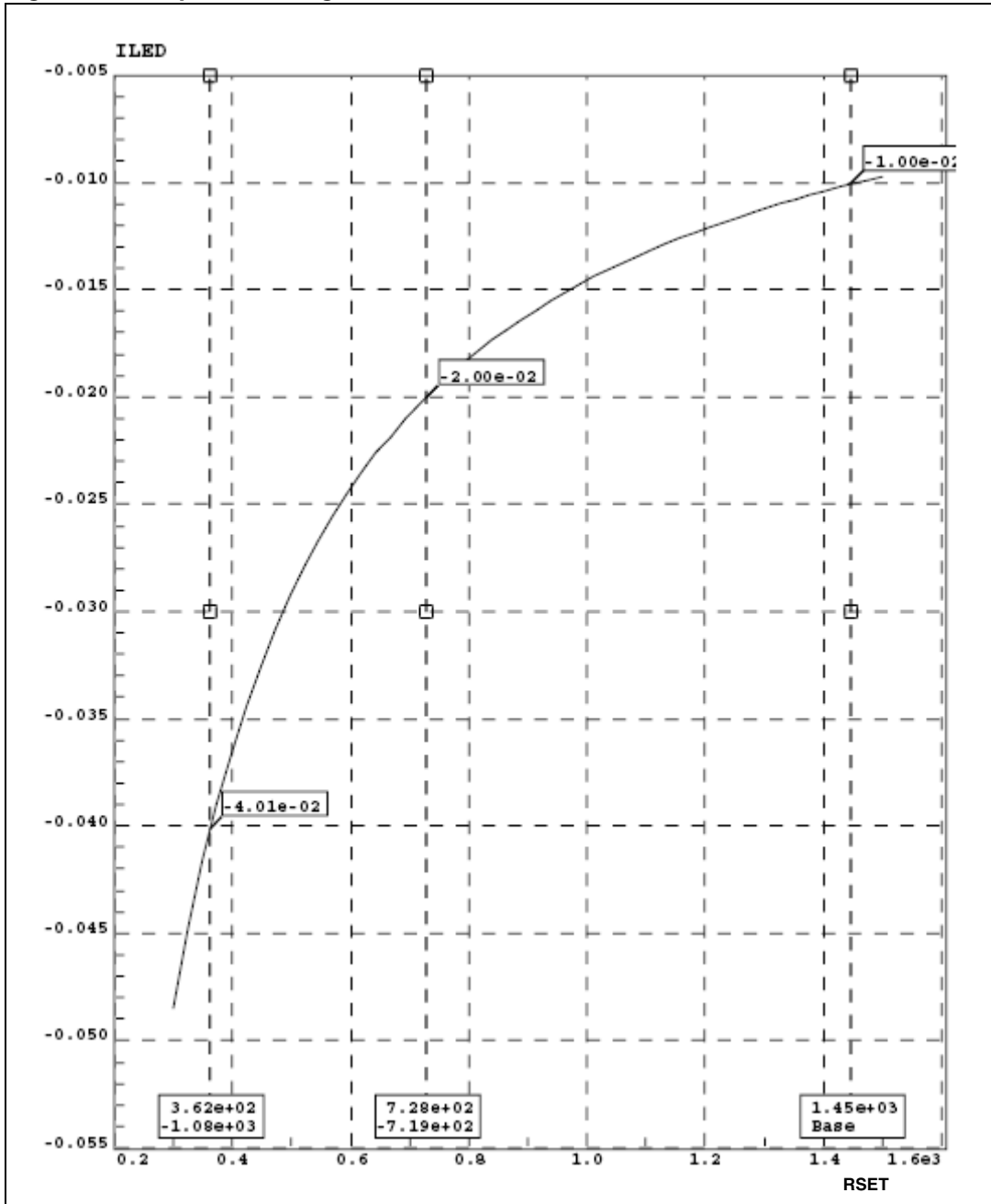

## 11.2 Power supply sequencing

Proper power-supply sequencing is advised for all CMOS devices. It is recommended to always apply  $V_{CC}$  before applying any signals to the input/output or control pins.

## 11.3 Application diagram

Figure 9. STLED316S application diagram

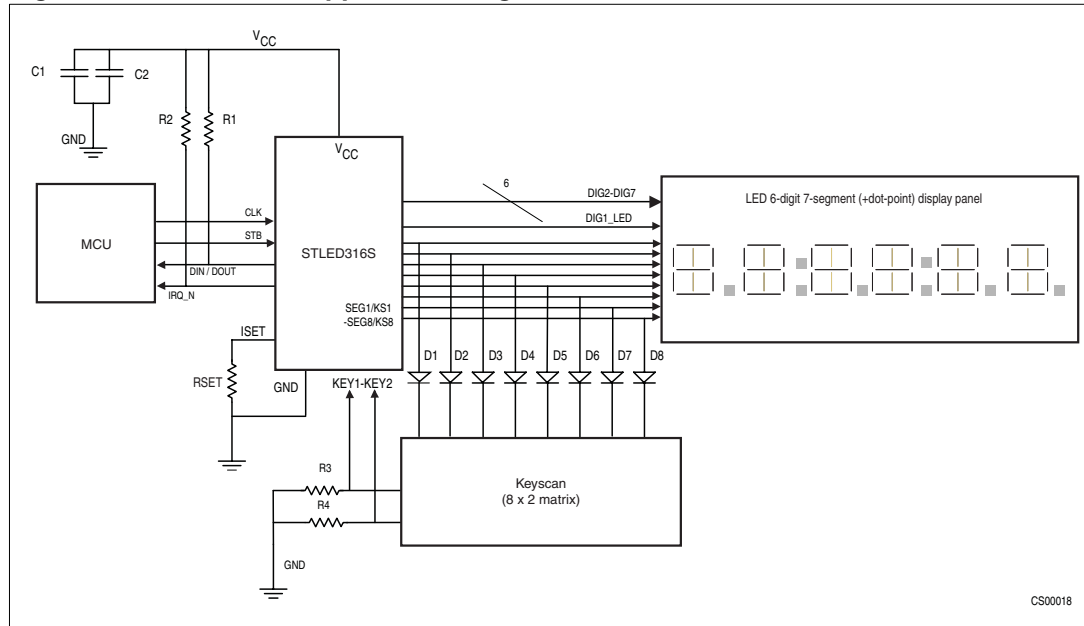

Table 19. Part list

| Resistors   | Capacitors                            | Diodes         | Supply V            |
|---|---------------------------------------|----------------|---------------------|
| RSET = external resistor for current setting                  | C1 = 33 $\mu$ F (25V) electrolytic    | D1-D8 = 1N4148 | VCC = 5 V $\pm$ 10% |
| R1 = 1-10 K $\Omega$ DIN/DOUT external pull-up resistor       | C2 = 0.01- 0.1 $\mu$ F (25 V) ceramic |                |                     |
| R2 = 1-10 K $\Omega$ IRQ_N external pull-up resistor          |                                       |                |                     |
| R3-R4 = 10 K $\Omega$ external key-matrix pull-down resistors |                                       |                |                     |

## 12 Package mechanical data

In order to meet environmental requirements, ST offers these devices in ECOPACK<sup>®</sup> packages. These packages have a Lead-free second level interconnect. The category of second level interconnect is marked on the package and on the inner box label, in compliance with JEDEC Standard JESD97. The maximum ratings related to soldering conditions are also marked on the inner box label. ECOPACK is an ST trademark. ECOPACK specifications are available at: [www.st.com](http://www.st.com).

Figure 10. SO-24 package outline

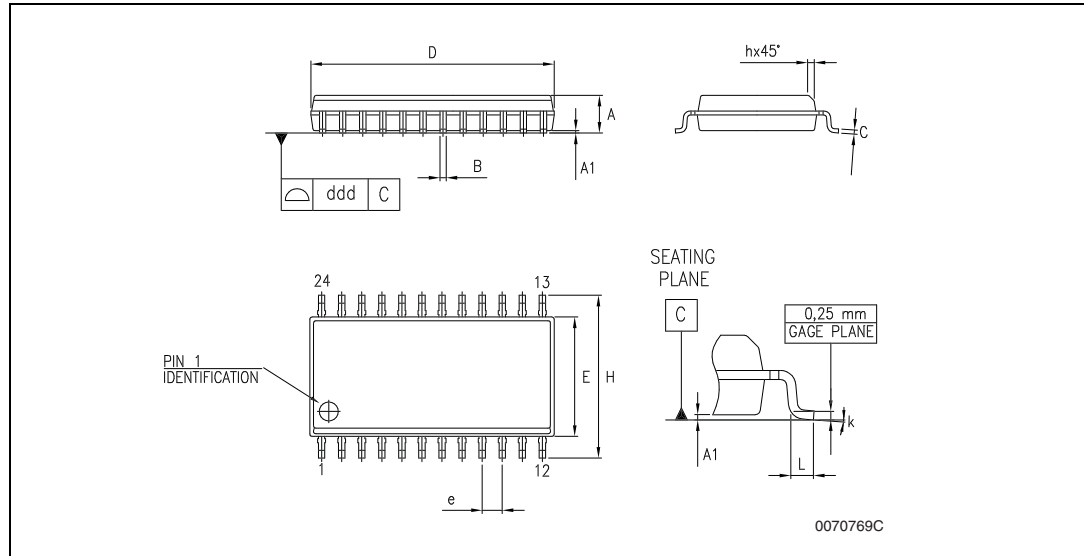

Table 20. SO-24 package mechanical data

| Symbol | millimeters |      |       | inches |       |       |
|--------|-------------|------|-------|--------|-------|-------|
|        | Min         | Typ  | Max   | Min    | Typ   | Max   |
| A      | 2.35        |      | 2.65  | 0.093  |       | 0.104 |
| A1     | 0.1         |      | 0.30  | 0.004  |       | 0.012 |
| B      | 0.33        |      | 0.51  | 0.013  |       | 0.020 |
| C      | 0.23        |      | 0.32  | 0.009  |       | 0.013 |
| D      | 15.20       |      | 15.60 | 0.598  |       | 0.614 |
| E      | 7.4         |      | 7.6   | 0.291  |       | 0.299 |
| e      |             | 1.27 |       |        | 0.050 |       |
| H      | 10.00       |      | 10.65 | 0.394  |       | 0.419 |
| h      | 0.25        |      | 0.75  | 0.010  |       | 0.030 |
| L      | 0.4         |      | 1.27  | 0.016  |       | 0.050 |
| k      | 0°          |      | 8°    | 0°     |       | 8°    |
| ddd    |             |      | 0.100 |        |       | 0.004 |

## 13 Revision history

Table 21. Document revision history

| Date       | Revision | Changes          |
|------------|----------|------------------|
| 9-Jan-2008 | 1        | Initial release. |



**Please Read Carefully:**

Information in this document is provided solely in connection with ST products. STMicroelectronics NV and its subsidiaries ("ST") reserve the right to make changes, corrections, modifications or improvements, to this document, and the products and services described herein at any time, without notice.

All ST products are sold pursuant to ST's terms and conditions of sale.

Purchasers are solely responsible for the choice, selection and use of the ST products and services described herein, and ST assumes no liability whatsoever relating to the choice, selection or use of the ST products and services described herein.

No license, express or implied, by estoppel or otherwise, to any intellectual property rights is granted under this document. If any part of this document refers to any third party products or services it shall not be deemed a license grant by ST for the use of such third party products or services, or any intellectual property contained therein or considered as a warranty covering the use in any manner whatsoever of such third party products or services or any intellectual property contained therein.

**UNLESS OTHERWISE SET FORTH IN ST'S TERMS AND CONDITIONS OF SALE ST DISCLAIMS ANY EXPRESS OR IMPLIED WARRANTY WITH RESPECT TO THE USE AND/OR SALE OF ST PRODUCTS INCLUDING WITHOUT LIMITATION IMPLIED WARRANTIES OF MERCHANTABILITY, FITNESS FOR A PARTICULAR PURPOSE (AND THEIR EQUIVALENTS UNDER THE LAWS OF ANY JURISDICTION), OR INFRINGEMENT OF ANY PATENT, COPYRIGHT OR OTHER INTELLECTUAL PROPERTY RIGHT.**

**UNLESS EXPRESSLY APPROVED IN WRITING BY AN AUTHORIZED ST REPRESENTATIVE, ST PRODUCTS ARE NOT RECOMMENDED, AUTHORIZED OR WARRANTED FOR USE IN MILITARY, AIR CRAFT, SPACE, LIFE SAVING, OR LIFE SUSTAINING APPLICATIONS, NOR IN PRODUCTS OR SYSTEMS WHERE FAILURE OR MALFUNCTION MAY RESULT IN PERSONAL INJURY, DEATH, OR SEVERE PROPERTY OR ENVIRONMENTAL DAMAGE. ST PRODUCTS WHICH ARE NOT SPECIFIED AS "AUTOMOTIVE GRADE" MAY ONLY BE USED IN AUTOMOTIVE APPLICATIONS AT USER'S OWN RISK.**

Resale of ST products with provisions different from the statements and/or technical features set forth in this document shall immediately void any warranty granted by ST for the ST product or service described herein and shall not create or extend in any manner whatsoever, any liability of ST.

ST and the ST logo are trademarks or registered trademarks of ST in various countries.

Information in this document supersedes and replaces all information previously supplied.

The ST logo is a registered trademark of STMicroelectronics. All other names are the property of their respective owners.

© 2008 STMicroelectronics - All rights reserved

STMicroelectronics group of companies

Australia - Belgium - Brazil - Canada - China - Czech Republic - Finland - France - Germany - Hong Kong - India - Israel - Italy - Japan - Malaysia - Malta - Morocco - Singapore - Spain - Sweden - Switzerland - United Kingdom - United States of America

[www.st.com](http://www.st.com)



Компания «ЭлектроПласт» предлагает заключение долгосрочных отношений при поставках импортных электронных компонентов на взаимовыгодных условиях!

Наши преимущества:

- Оперативные поставки широкого спектра электронных компонентов отечественного и импортного производства напрямую от производителей и с крупнейших мировых складов;
- Поставка более 17-ти миллионов наименований электронных компонентов;
- Поставка сложных, дефицитных, либо снятых с производства позиций;
- Оперативные сроки поставки под заказ (от 5 рабочих дней);
- Экспресс доставка в любую точку России;
- Техническая поддержка проекта, помощь в подборе аналогов, поставка прототипов;
- Система менеджмента качества сертифицирована по Международному стандарту ISO 9001;
- Лицензия ФСБ на осуществление работ с использованием сведений, составляющих государственную тайну;
- Поставка специализированных компонентов (Xilinx, Altera, Analog Devices, Intersil, Interpoint, Microsemi, Aeroflex, Peregrine, Syfer, Eurofarad, Texas Instrument, Miteq, Cobham, E2V, MA-COM, Hittite, Mini-Circuits, General Dynamics и др.);

Помимо этого, одним из направлений компании «ЭлектроПласт» является направление «Источники питания». Мы предлагаем Вам помощь Конструкторского отдела:

- Подбор оптимального решения, техническое обоснование при выборе компонента;
- Подбор аналогов;
- Консультации по применению компонента;
- Поставка образцов и прототипов;
- Техническая поддержка проекта;
- Защита от снятия компонента с производства.



#### Как с нами связаться

**Телефон:** 8 (812) 309 58 32 (многоканальный)

**Факс:** 8 (812) 320-02-42

**Электронная почта:** [org@eplast1.ru](mailto:org@eplast1.ru)

**Адрес:** 198099, г. Санкт-Петербург, ул. Калинина, дом 2, корпус 4, литера А.