

## PROTECTION PRODUCTS

### Description

P Clamp TVS diodes are designed for use in harsh transient environments to protect sensitive electronics from damage or latch-up due to EOS, lightning, CDE, and ESD. They feature large cross-sectional area junctions for conducting high transient currents. These devices offer desirable characteristics for board level protection including fast response time, low operating and clamping voltage, and no device degradation.

They feature extremely good protection characteristics highlighted by high surge current capability (180A,  $t_p = 8/20\mu s$ ), low peak ESD clamping voltage, and high ESD withstand voltage (+/- 30kV per IEC 61000-4-2). Each device will protect power line operating up to 13.5V.

P Clamp1211P is in a 6-pin SLP2018P6 package measuring 2.0 x 1.8 mm with a nominal height of 0.57mm. The leads are finished with lead-free NiPdAu. High surge current capability and low clamping voltage making them ideal for protecting VBus, battery, and other power lines in portable electronics, industrial, and automotive applications.

### Features

- Transient Protection to
  - ♦ IEC 61000-4-2 (ESD) 30kV (Air), 30kV (Contact)
  - ♦ IEC 61000-4-4 (EFT) 4kV (5/50ns)
  - ♦ IEC 61000-4-5 (Lightning) 180A (8/20 $\mu s$ )
  - ♦ ISO-10605 (ESD) 30kV (Air), 30kV (Contact)
- Protects power line
- Working Voltage: 13.5V
- Low leakage current
- Solid-state silicon-avalanche technology

### Mechanical Characteristics

- SLP2018P6 package
- Pb-Free, Halogen Free, RoHS/WEEE compliant
- Nominal Dimensions: 2.0 x 1.8 x 0.57 mm
- Lead Finish: NiPdAu
- Marking: Marking code
- Packaging: Tape and Reel

### Applications

- Cellular Handsets & Accessories
- Industrial Equipment
- Voltage Supply Lines
- Battery protection
- USB VBus

### Schematic

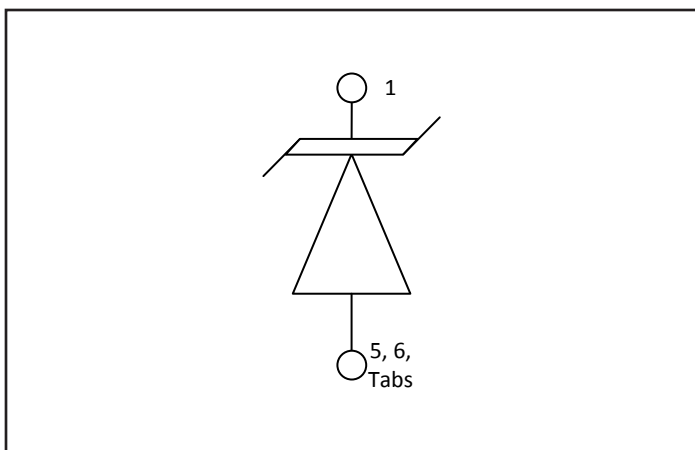

### Pin Configuration

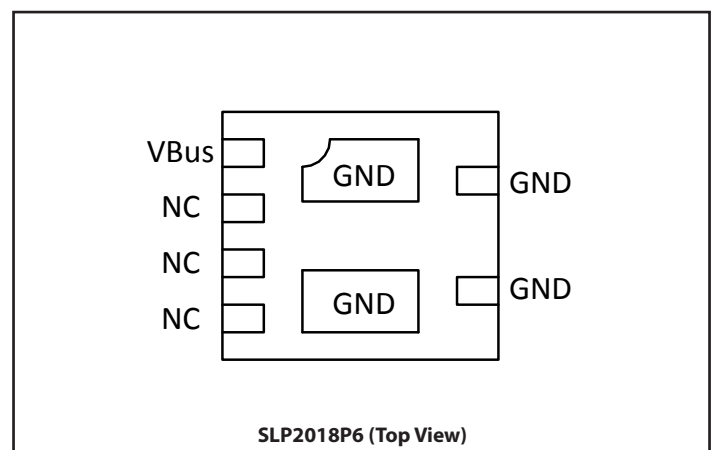

## Absolute Maximum Ratings

Rating	Symbol	Value	Units
Peak Pulse Power (tp = 8/20μs)	P <sub>PK</sub>	5000	W
Peak Pulse Current (tp = 8/20μs)	I <sub>PP</sub>	180	A
Peak Pulse Current (tp = 10/1000μs)	I <sub>PP</sub>	15	A
ESD per IEC 61000-4-2 (Contact) <sup>(1)</sup> ESD per IEC 61000-4-2 (Air) <sup>(1)</sup>	V <sub>ESD</sub>	±30 ±30	kV
Operating Temperature	T <sub>J</sub>	-40 to +125	°C
Storage Temperature	T <sub>STG</sub>	-55 to +150	°C

## Electrical Characteristics (T=25°C unless otherwise specified)

P Clamp1211P						
Parameter	Symbol	Conditions	Min.	Typ.	Max.	Units
Reverse Stand-Off Voltage	V <sub>RWM</sub>	Pin 1 to Pin 5, 6 <sup>(5)</sup>			13.5	V
Reverse Breakdown Voltage	V <sub>BR</sub>	I <sub>t</sub> = 1mA, Pin 1 to Pin 5, 6 <sup>(5)</sup>	14.5	15	17.5	V
Reverse Leakage Current	I <sub>R</sub>	V <sub>RWM</sub> = 13.5V Pin 1 to Pin 5, 6 <sup>(5)</sup>		0.300	0.350	μA
Clamping Voltage <sup>(2)</sup>	V <sub>C</sub>	I <sub>PP</sub> = 100A, tp = 8/20μs, Pin 1 to Pin 5, 6 <sup>(5)</sup>		18	25	V
Clamping Voltage <sup>(2)</sup>	V <sub>C</sub>	I <sub>PP</sub> = 180A, tp = 8/20μs, Pin 1 to Pin 5, 6 <sup>(5)</sup>		23.5	28	V
Dynamic Resistance <sup>(3), (4)</sup>	R <sub>DYN</sub>	tp = 0.2/100ns (TLP) Pin 1 to Pin 5, 6 <sup>(5)</sup>		0.01		Ohms
Junction Capacitance	C <sub>J</sub>	V <sub>R</sub> = 0V, f = 1MHz Pin 1 to Pin 5, 6 <sup>(5)</sup>		1500	2500	pF

Notes:

(1): ESD Gun return path to Ground Reference Plane (GRP)

(2): Tested using a constant current source

(3): Transmission Line Pulse Test (TLP) Settings: tp = 100ns, tr = 0.2ns, I<sub>TLP</sub> and V<sub>TLP</sub> averaging window: t<sub>1</sub> = 70ns to t<sub>2</sub> = 90ns.

(4): Dynamic resistance calculated from I<sub>TLP</sub> = 4A to I<sub>TLP</sub> = 16A

(5) Pins 5 and 6 are electrically connected to the center tabs

# Typical Characteristics

### Non-Repetitive Peak Pulse Power vs. Pulse Time

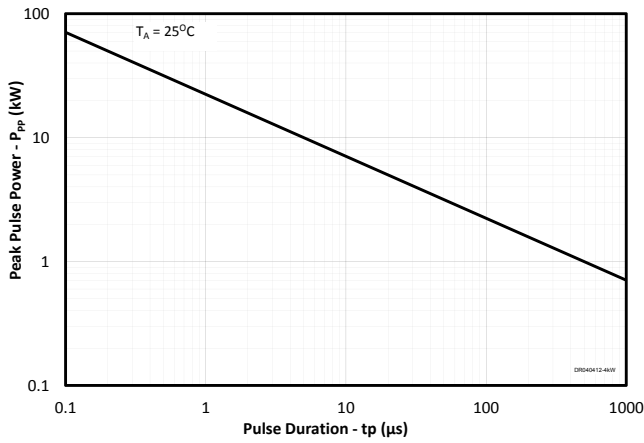

### Power Derating Curve

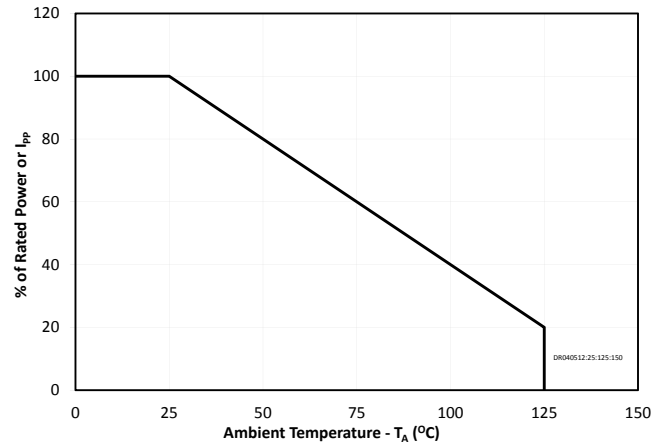

### Clamping Voltage vs. Peak Pulse Current ( $t_p=8/20\mu$ s)

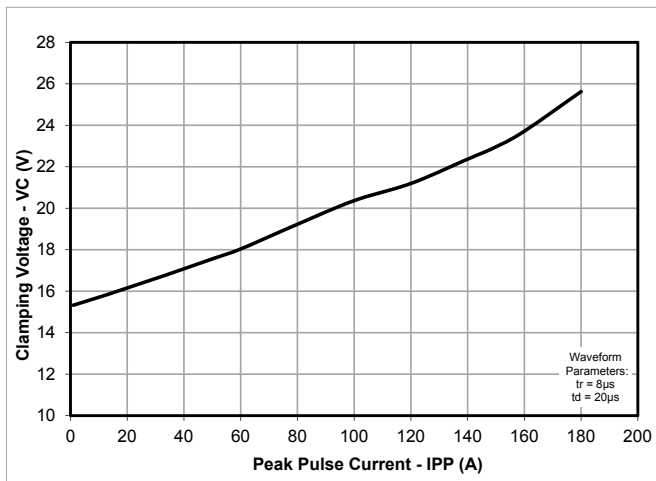

### Forward Voltage vs. Peak Pulse Current ( $t_p=8/20\mu$ s)

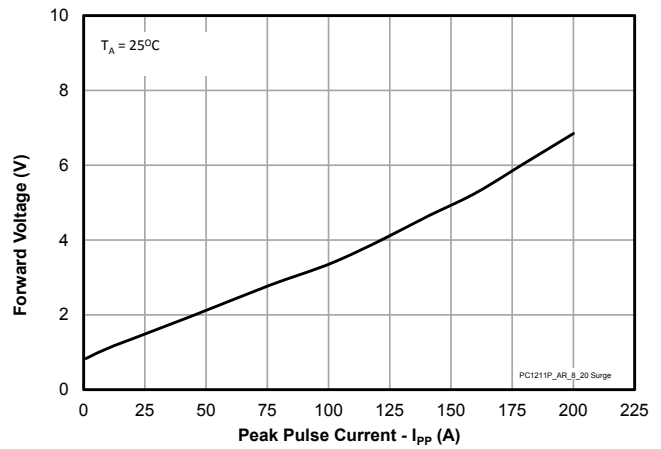

### Breakdown Voltage ( $V_{BR}$ ) vs. Temperature

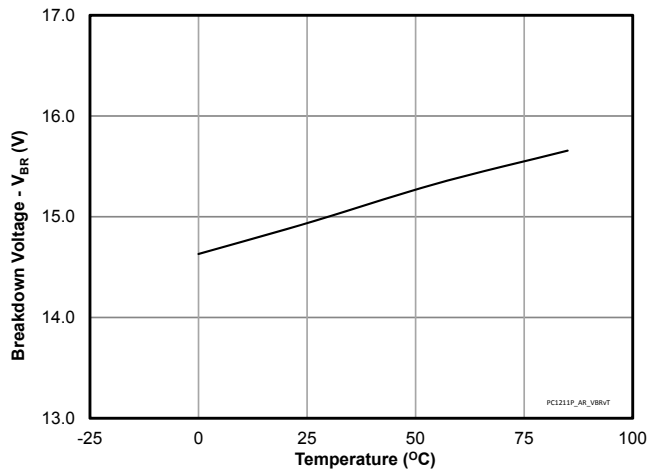

### TLP Characteristic

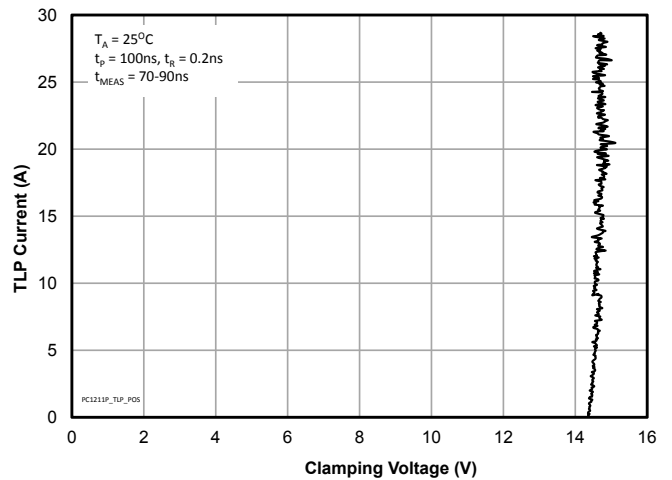

# Typical Characteristics

ESD Clamping (8kV Contact per IEC 61000-4-2)

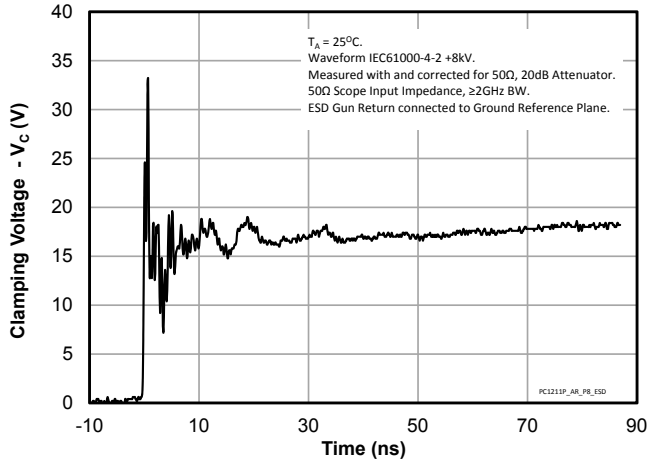

ESD Clamping (-8kV Contact per IEC 61000-4-2)

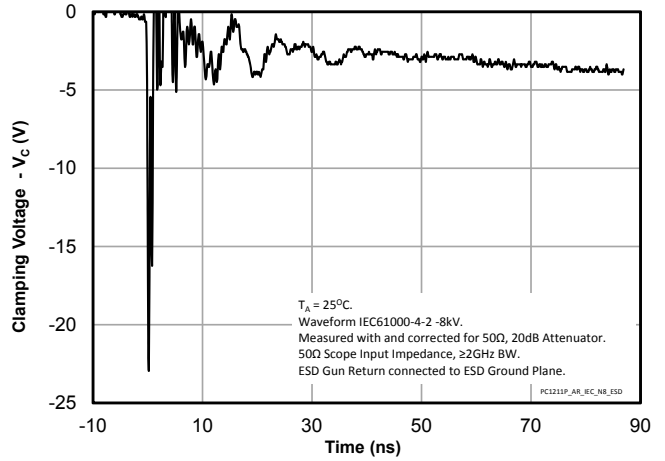

ESD Clamping (30kV Contact per IEC 61000-4-2)

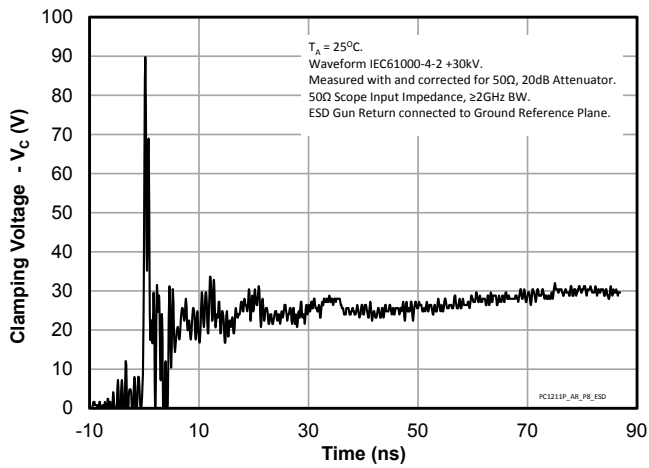

ESD Clamping (-30kV Contact per IEC 61000-4-2)

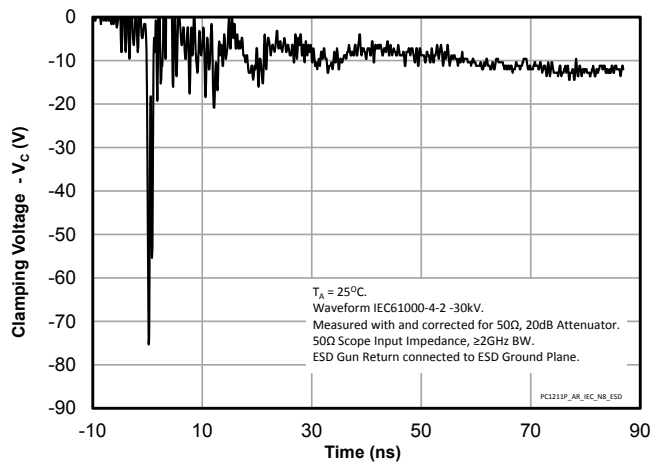

# Application Information

## Assembly Guidelines

The figure at the right details Semtech’s recommended mounting pattern. Recommended assembly guidelines are shown in Table 1. Note that these are only recommendations and should serve only as a starting point for design since there are many factors that affect the assembly process. Exact manufacturing parameters will require some experimentation to get the desired solder application. Semtech’s recommended mounting pattern is based on the following design guidelines:

### Land Pattern

The recommended land pattern follows IPC standards and is designed for maximum solder coverage. Detailed dimensions are shown elsewhere in this document.

### Solder Stencil

Stencil design is one of the key factors which will determine the volume of solder paste deposited onto the land pad. The area ratio of the stencil aperture will determine how well the stencil will print. The area ratio takes into account the aperture shape, aperture size, and stencil thickness. An area ratio of 0.70 – 0.75 is preferred for the subject package. The area ratio of a rectangular aperture is given as:

$$\text{Area Ratio} = (L * W) / (2 * (L + W) * T)$$

Where:

- L = Aperture Length
- W = Aperture Width
- T = Stencil Thickness

Semtech recommends a stencil thickness of 0.125mm for this device. The stencil should be laser cut with electro-polished finish. The stencil should have a positive taper of approximately 5 degrees. Electro polishing and tapering the walls results in reduced surface friction and better paste release. Solder paste with Type 3 or smaller particles are recommended. Assuming a 125µm thick stencil, the aperture dimensions shown will yield an area ratio of approximately 0.75.

## Recommended Mounting Pattern

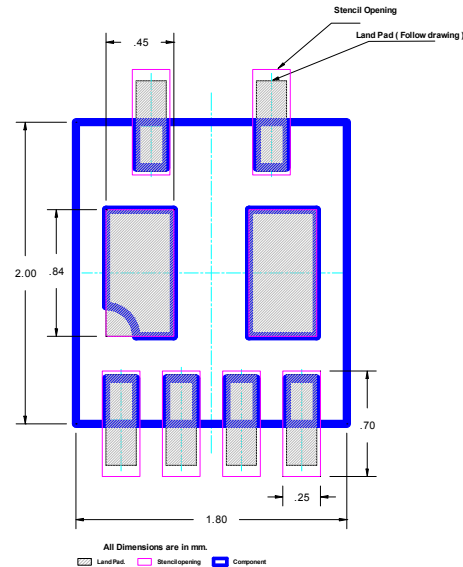

Assembly Parameter	Recommendation
Solder Stencil Design	Laser Cut, Electro-Polished
Aperture Shape	Rectangular
Solder Stencil Thickness	0.125mm (0.005")
Solder Paste Type	Type 3 size sphere or smaller
Solder Reflow Profile	Per JEDEC J-STD-020
PCB Solder pad Design	Non-Solder Mask Defined
PCB Pad Finish	OSP or NiAu

# Outline Drawing - SLP2018P6

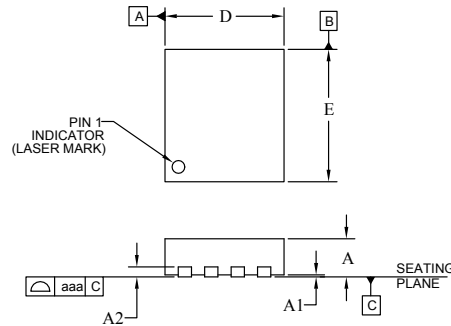

DIMENSIONS			
DIM	MILLIMETERS		
	MIN	NOM	MAX
A	0.50	0.575	0.65
A1	0.00	0.03	0.05
A2	(0.127)		
b	0.15	0.20	0.25
D	1.70	1.80	1.90
E	1.90	2.00	2.10
D1	0.30	0.45	0.55
E1	0.69	0.84	0.94
e	0.40 BSC		
e1	0.80 BSC		
L	0.25	0.30	0.35
N	6		
aaa	0.08		
bbb	0.10		

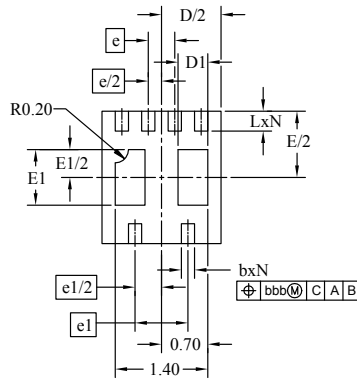

NOTES:  
1. CONTROLLING DIMENSIONS ARE IN MILLIMETERS (ANGLES IN DEGREES).

# Land Pattern - SLP2018P6

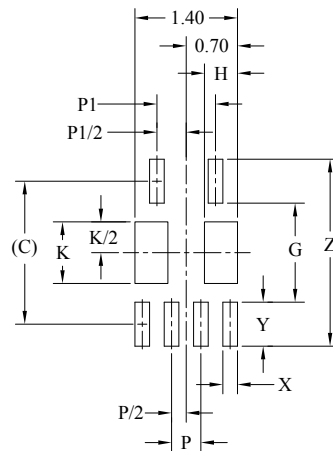

DIMENSIONS	
DIM	MILLIMETERS
C	(1.95)
G	1.35
H	0.45
K	0.84
P	0.40
P1	0.80
X	0.20
Y	0.60
Z	2.55

NOTES:  
1. CONTROLLING DIMENSIONS ARE IN MILLIMETERS (ANGLES IN DEGREES).  
2. THIS LAND PATTERN IS FOR REFERENCE PURPOSES ONLY. CONSULT YOUR MANUFACTURING GROUP TO ENSURE YOUR COMPANY'S MANUFACTURING GUIDELINES ARE MET.

## Marking Example

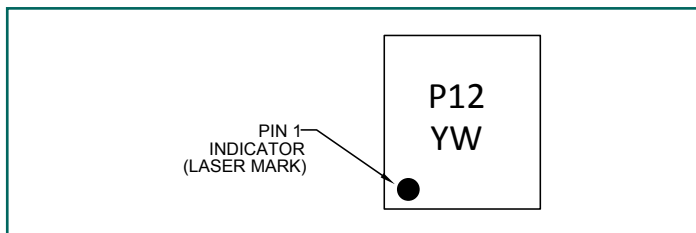

## Tape and Reel Specification

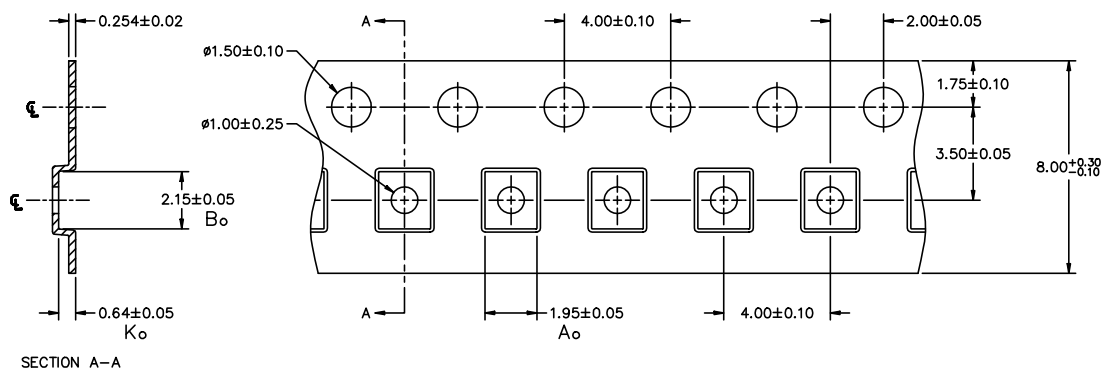

NOTE: ALL DIMENSIONS IN MILLIMETERS UNLESS OTHERWISE SPECIFIED.

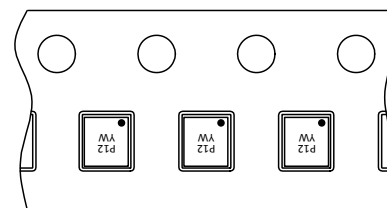

Pin 1 Located Towards Sprocket Holes

## Ordering Information

Part Number	Working Voltage	Qty per Reel	Reel Size
P Clamp1211P.TGT	12V	10,000	13"
P Clamp and MicroClamp are trademarks of Semtech Corporation			



---

#### IMPORTANT NOTICE

Information relating to this product and the application or design described herein is believed to be reliable, however such information is provided as a guide only and Semtech assumes no liability for any errors in this document, or for the application or design described herein. Semtech reserves the right to make changes to the product or this document at any time without notice. Buyers should obtain the latest relevant information before placing orders and should verify that such information is current and complete. Semtech warrants performance of its products to the specifications applicable at the time of sale, and all sales are made in accordance with Semtech's standard terms and conditions of sale.

SEMTECH PRODUCTS ARE NOT DESIGNED, INTENDED, AUTHORIZED OR WARRANTED TO BE SUITABLE FOR USE IN LIFE-SUPPORT APPLICATIONS, DEVICES OR SYSTEMS, OR IN NUCLEAR APPLICATIONS IN WHICH THE FAILURE COULD BE REASONABLY EXPECTED TO RESULT IN PERSONAL INJURY, LOSS OF LIFE OR SEVERE PROPERTY OR ENVIRONMENTAL DAMAGE. INCLUSION OF SEMTECH PRODUCTS IN SUCH APPLICATIONS IS UNDERSTOOD TO BE UNDERTAKEN SOLELY AT THE CUSTOMER'S OWN RISK. Should a customer purchase or use Semtech products for any such unauthorized application, the customer shall indemnify and hold Semtech and its officers, employees, subsidiaries, affiliates, and distributors harmless against all claims, costs damages and attorney fees which could arise.

The Semtech name and logo are registered trademarks of the Semtech Corporation. All other trademarks and trade names mentioned may be marks and names of Semtech or their respective companies. Semtech reserves the right to make changes to, or discontinue any products described in this document without further notice. Semtech makes no warranty, representation or guarantee, express or implied, regarding the suitability of its products for any particular purpose. All rights reserved.

© Semtech 2015

---

#### Contact Information

Semtech Corporation  
200 Flynn Road, Camarillo, CA 93012  
Phone: (805) 498-2111, Fax: (805) 498-3804  
[www.semtech.com](http://www.semtech.com)





Компания «ЭлектроПласт» предлагает заключение долгосрочных отношений при поставках импортных электронных компонентов на взаимовыгодных условиях!

Наши преимущества:

- Оперативные поставки широкого спектра электронных компонентов отечественного и импортного производства напрямую от производителей и с крупнейших мировых складов;
- Поставка более 17-ти миллионов наименований электронных компонентов;
- Поставка сложных, дефицитных, либо снятых с производства позиций;
- Оперативные сроки поставки под заказ (от 5 рабочих дней);
- Экспресс доставка в любую точку России;
- Техническая поддержка проекта, помощь в подборе аналогов, поставка прототипов;
- Система менеджмента качества сертифицирована по Международному стандарту ISO 9001;
- Лицензия ФСБ на осуществление работ с использованием сведений, составляющих государственную тайну;
- Поставка специализированных компонентов (Xilinx, Altera, Analog Devices, Intersil, Interpoint, Microsemi, Aeroflex, Peregrine, Syfer, Eurofarad, Texas Instrument, Miteq, Cobham, E2V, MA-COM, Hittite, Mini-Circuits, General Dynamics и др.);

Помимо этого, одним из направлений компании «ЭлектроПласт» является направление «Источники питания». Мы предлагаем Вам помощь Конструкторского отдела:

- Подбор оптимального решения, техническое обоснование при выборе компонента;
- Подбор аналогов;
- Консультации по применению компонента;
- Поставка образцов и прототипов;
- Техническая поддержка проекта;
- Защита от снятия компонента с производства.



#### Как с нами связаться

**Телефон:** 8 (812) 309 58 32 (многоканальный)

**Факс:** 8 (812) 320-02-42

**Электронная почта:** [org@eplast1.ru](mailto:org@eplast1.ru)

**Адрес:** 198099, г. Санкт-Петербург, ул. Калинина, дом 2, корпус 4, литера А.