

Specification

AX32X0

SSC		고객명
Drawn	Approval	Approval

Contents

1. Part number of AX32X0
2. Outline dimensions
3. Characteristics of Acriche
4. Color spectrum, Ta=25°C
5. Current – Voltage characteristics, Ta=25°C
6. Voltage – Relative flux characteristics, Ta=25°C
7. Relative Flux – Junction temperature characteristics
8. Typical dome type radiation pattern, Ta=25°C
9. Acriche Binning structure graphical representation
10. Operating instructions of AX32X0
11. Recommended solder pad
12. Solder profile
13. Packaging
14. Precaution for use
15. Handling of silicone resin for LEDs

AX32X0

Description

The Acriche series of LEDs are designed for AC operation and high flux output applications. Acriche LEDs are an environmentally friendly semiconductor lighting source that can be directly connected to an AC power source without any DC conversion required.

Acriche's thermal management performance exceeds other power LED solutions by incorporating state-of-the-art SMD design and use of specialized thermal emission material. Acriche is an ideal light source for general purpose illumination applications



AX32X0

Features

- Connect directly to AC power
- Power Saving
- Long Life
- Simplified B.O.M
- Small design footprint
- Low thermal resistance
- SMT solderability
- Lead Free and RoHS compliant

Applications

- Architectural lighting
- Task lighting
- Decorative and Pathway lighting
- White goods and gaming
- Spot lighting

* product specification may change without notice

Part number of AX32X0

1. Part Number form : A X₁ X₂ X₃ X₄ X₅

X ₁	Color
W	Pure White
N	Warm White

X ₂	Acrich Series
1	-
2	-
3	A3

X ₃	LENS Type
2	Dome Type

X ₄	Operating Voltage [V]
0	100 / 110 / 120
1	-
2	220 / 230
3	-

X ₅	PCB Type
0	Emitter
1	-

2. Part Number of AX32X0

Part number	Operating voltage	Operating current
AW3200 / AN3200	100V/110V/120 [RMS]	40mA [RMS]
AW3220 / AN3220	220V/230V [RMS]	20mA [RMS]

Outline dimensions

1. AX3200

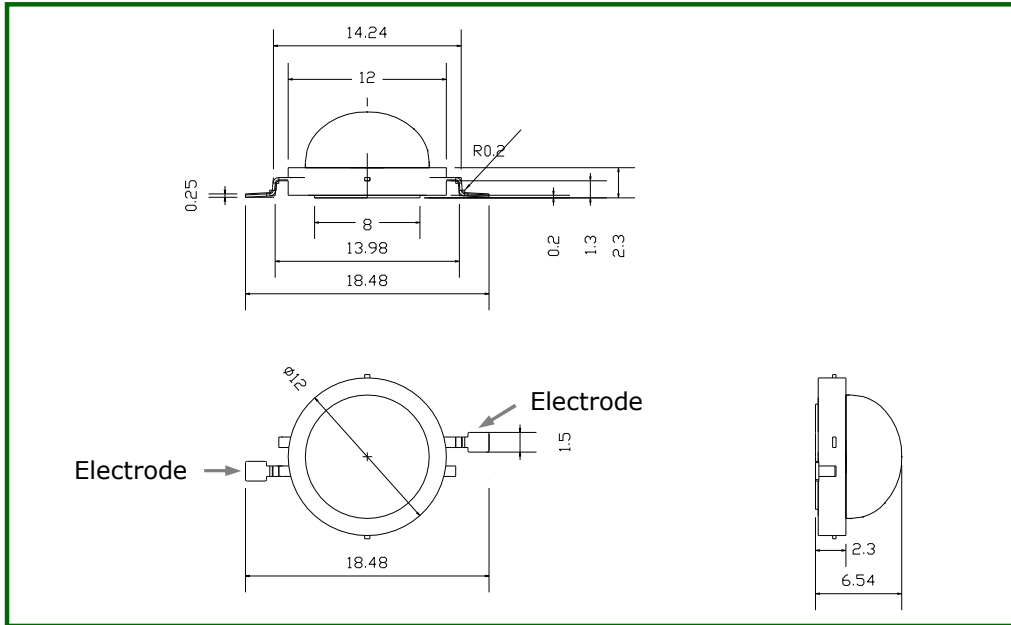

2. AX3220

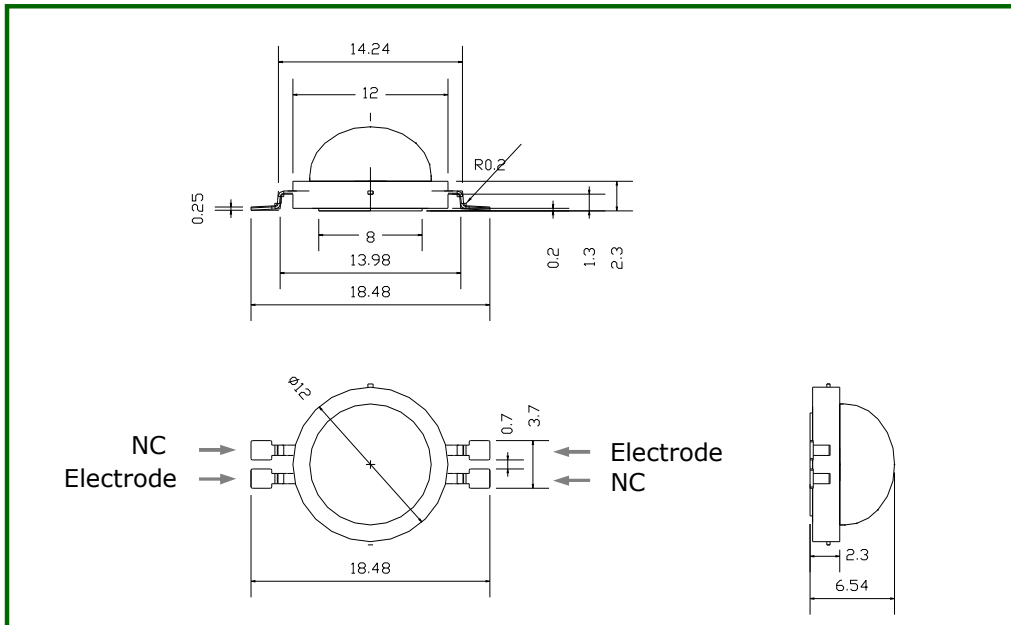

Notes :

- [1] All dimensions are in millimeters. (tolerance: ± 0.2)
- [2] Scale : none
- [3] Slug of package is electrically isolated
- [4] NC pin has no electrical or thermal connection

Characteristics of Acriche

1. AW3200

1-1 Electro-Optical characteristics at 100V/110V/120V Ta=25°C

Parameter	Symbol	Value			Unit
		Min	Typ	Max	
Luminous Flux ^[1]	Φ_V ^[2]	-	330	-	lm
Illuminance ^[3]	Φ_I	-	365	-	lx
Correlated Color Temperature ^[4]	CCT	-	6300	-	K
CRI	R _a	-	65	-	-
Operating Current	I _{opt}	-	40	-	mA [RMS]
Power Dissipation	P _D	3.3			W
Operating Frequency	Freq	50 / 60			Hz
View Angle	2 Θ 1/2	130			deg.

1-2 Absolute Maximum Ratings

Parameter	Symbol	Value	Unit
Operating Voltage	V _{opt} ^[5]	115/127/138	V [RMS]
Power Dissipation	P _D	6.4	W
Junction Temperature	T _j	125	°C
Operating Temperature	T _{opr}	-40 ~ +85	°C
Storage Temperature	T _{stg}	-40 ~ +120	°C
ESD Sensitivity	-	±2,000V HBM	-

*Notes :

- [1] Acriche series maintains a tolerance of ±10% on flux and power measurements.
- [2] Φ_V is the total luminous flux output as measured with an integrating sphere.
- [3] Illuminance is measured at 50cm distance
- [4] Correlated Color Temperature is derived from the CIE 1931 Chromaticity diagram.
CCT ±5% tester tolerance
- [5] 'Operating Voltage' doesn't indicate the maximum voltage which customers use, but it means tolerable voltage according to the voltage variation rate by one's country.
It is recommended that the temperature of lead frame should be below 70 °C.

Characteristics of Acriche

2. AN3200

1-1 Electro-Optical characteristics at 100V/110V/120V Ta=25°C

Parameter	Symbol	Value			Unit
		Min	Typ	Max	
Luminous Flux ^[1]	Φ_V ^[2]	-	220	-	lm
Illuminance ^[3]	Φ_I	-	245	-	lx
Correlated Color Temperature ^[4]	CCT	-	3000	-	K
CRI	R _a	-	80	-	-
Operating Current	I _{opt}	-	40	-	mA [RMS]
Power Dissipation	P _D	3.3			W
Operating Frequency	Freq	50 / 60			Hz
View Angle	2 Θ 1/2	130			deg.

1-2 Absolute Maximum Ratings

Parameter	Symbol	Value	Unit
Operating Voltage	V _{opt} ^[5]	115/127/138	V [RMS]
Power Dissipation	P _D	6.4	W
Junction Temperature	T _j	125	°C
Operating Temperature	T _{opr}	-40 ~ +85	°C
Storage Temperature	T _{stg}	-40 ~ +120	°C
ESD Sensitivity	-	±2,000V HBM	-

*Notes :

- [1] Acriche series maintains a tolerance of ±10% on flux and power measurements.
- [2] Φ_V is the total luminous flux output as measured with an integrating sphere.
- [3] Illuminance is measured at 50cm distance
- [4] Correlated Color Temperature is derived from the CIE 1931 Chromaticity diagram.
CCT ±5% tester tolerance
- [5] 'Operating Voltage' doesn't indicate the maximum voltage which customers use, but it means tolerable voltage according to the voltage variation rate by one's country.
It is recommended that the temperature of lead frame should be below 70 °C.

Characteristics of Acriche

3. AW3220

1-1 Electro-Optical characteristics at 220V/230V Ta=25°C

Parameter	Symbol	Value			Unit
		Min	Typ	Max	
Luminous Flux ^[1]	Φ_V ^[2]	-	330	-	lm
Illuminance ^[3]	Φ_I	-	365	-	lx
Correlated Color Temperature ^[4]	CCT	-	6300	-	K
CRI	R _a	-	65	-	-
Operating Current	I _{opt}	-	20	-	mA [RMS]
Power Dissipation	P _D	3.3			W
Operating Frequency	Freq	50 / 60			Hz
View Angle	2 Θ 1/2	130			deg.

1-2 Absolute Maximum Ratings

Parameter	Symbol	Value	Unit
Operating Voltage	V _{opt} ^[5]	253/265	V [RMS]
Power Dissipation	P _D	6.4	W
Junction Temperature	T _j	125	°C
Operating Temperature	T _{opr}	-40 ~ +85	°C
Storage Temperature	T _{stg}	-40 ~ +120	°C
ESD Sensitivity	-	±2,000V HBM	-

*Notes :

- [1] Acriche series maintains a tolerance of ±10% on flux and power measurements.
- [2] Φ_V is the total luminous flux output as measured with an integrating sphere.
- [3] Illuminance is measured at 50cm distance
- [4] Correlated Color Temperature is derived from the CIE 1931 Chromaticity diagram.
CCT ±5% tester tolerance
- [5] 'Operating Voltage' doesn't indicate the maximum voltage which customers use, but it means tolerable voltage according to the voltage variation rate by one's country.
It is recommended that the temperature of lead frame should be below 70 °C.

Characteristics of Acriche

4. AN3220

1-1 Electro-Optical characteristics at 220V/230V Ta=25°C

Parameter	Symbol	Value			Unit
		Min	Typ	Max	
Luminous Flux ^[1]	Φ_V ^[2]	-	220	-	lm
Illuminance ^[3]	Φ_I	-	245	-	lx
Correlated Color Temperature ^[4]	CCT	-	3000	-	K
CRI	R _a	-	80	-	-
Operating Current	I _{opt}	-	20	-	mA [RMS]
Power Dissipation	P _D	3.3			W
Operating Frequency	Freq	50 / 60			Hz
View Angle	2 Θ 1/2	130			deg.

1-2 Absolute Maximum Ratings

Parameter	Symbol	Value	Unit
Operating Voltage	V _{opt} ^[5]	253/265	V [RMS]
Power Dissipation	P _D	6.4	W
Junction Temperature	T _j	125	°C
Operating Temperature	T _{opr}	-40 ~ +85	°C
Storage Temperature	T _{stg}	-40 ~ +120	°C
ESD Sensitivity	-	±2,000V HBM	-

*Notes :

- [1] Acriche series maintains a tolerance of ±10% on flux and power measurements.
- [2] Φ_V is the total luminous flux output as measured with an integrating sphere.
- [3] Illuminance is measured at 50cm distance
- [4] Correlated Color Temperature is derived from the CIE 1931 Chromaticity diagram.
CCT ±5% tester tolerance
- [5] 'Operating Voltage' doesn't indicate the maximum voltage which customers use, but it means tolerable voltage according to the voltage variation rate by one's country.
It is recommended that the temperature of lead frame should be below 70 °C.

Color spectrum, Ta=25°C

1. Pure white

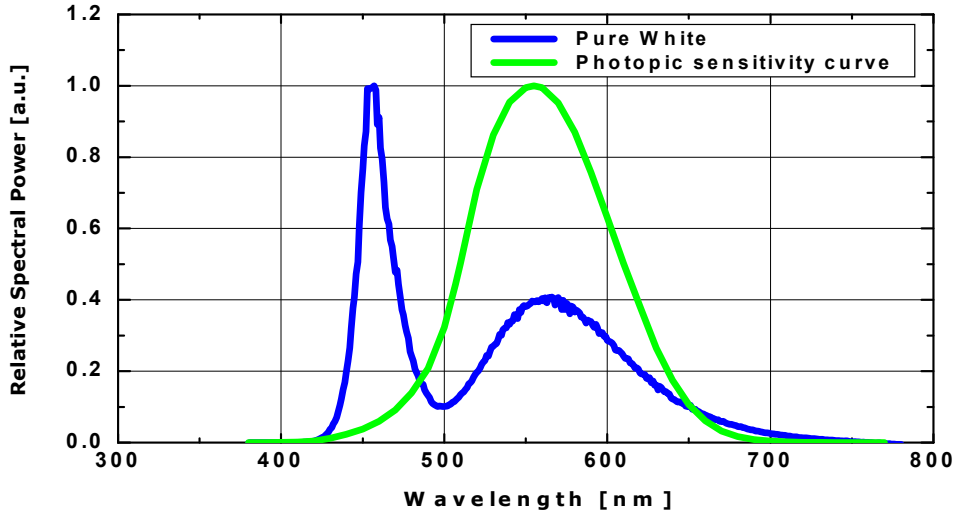

2. Warm white

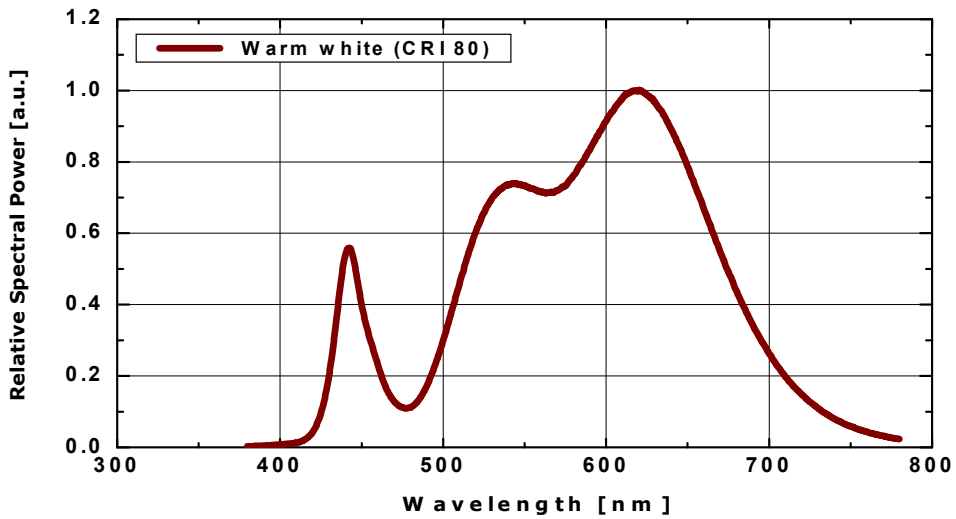

Current – Voltage characteristics, Ta=25°C

1. AX3200 with external resistor @100V

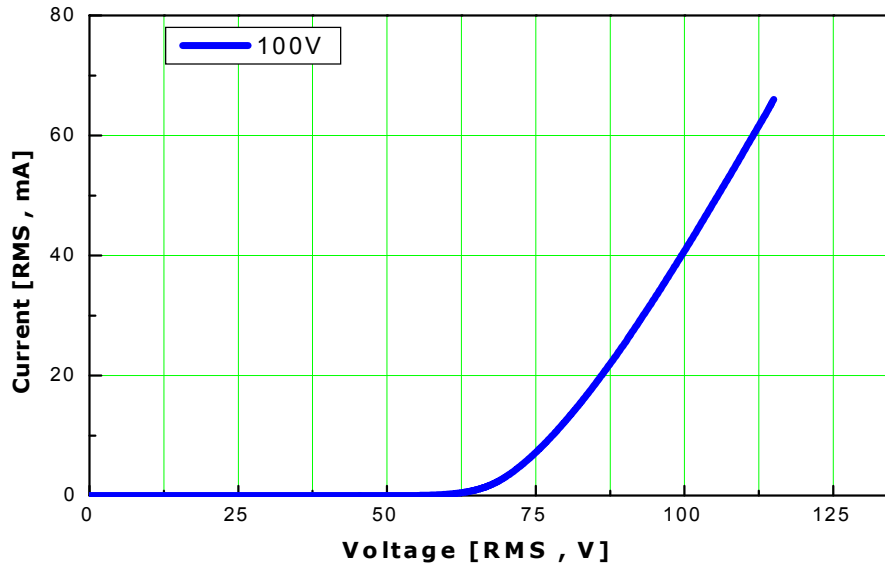

2. AX3200 with external resistor @110V

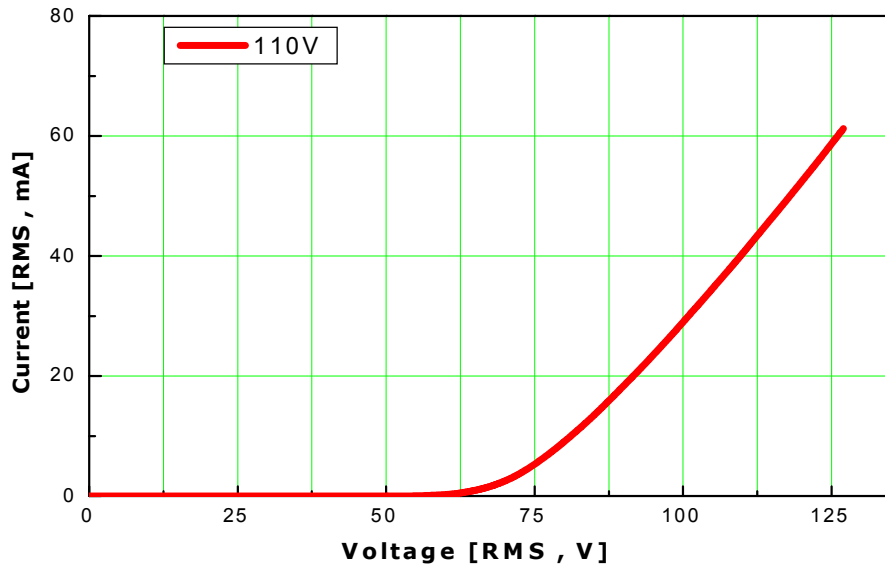

Current – Voltage characteristics, Ta=25°C

3. AX3200 with external resistor @120V

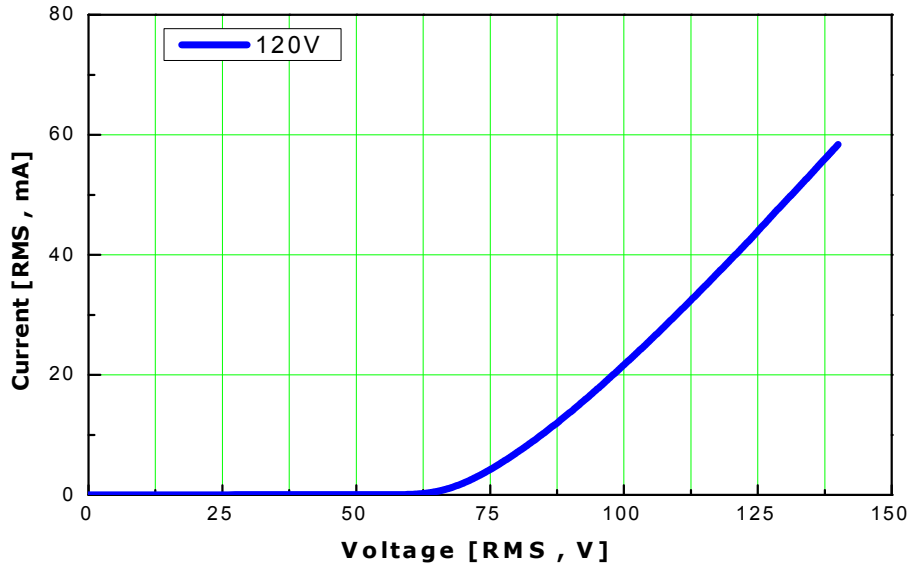

Current – Voltage characteristics, Ta=25°C

4. AX3220 with external resistor @220V

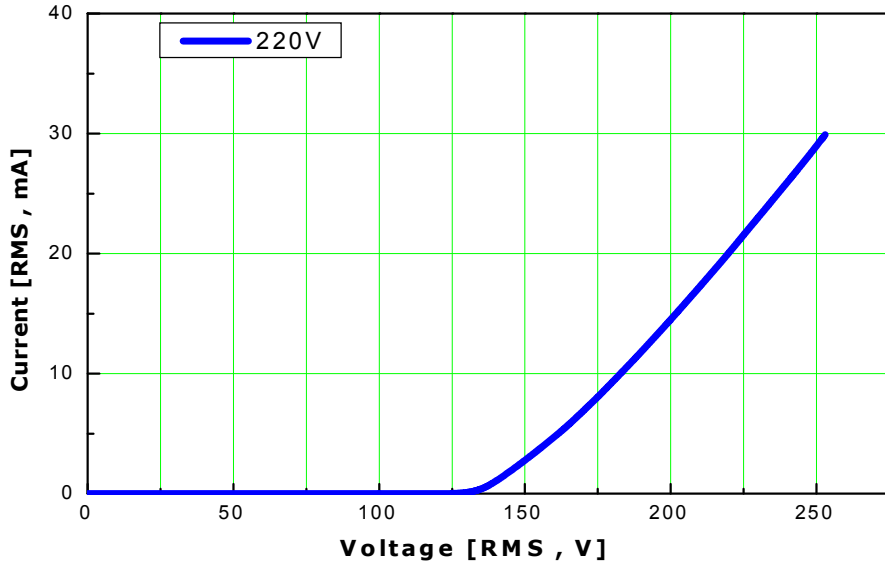

5. AX3220 with external resistor @230V

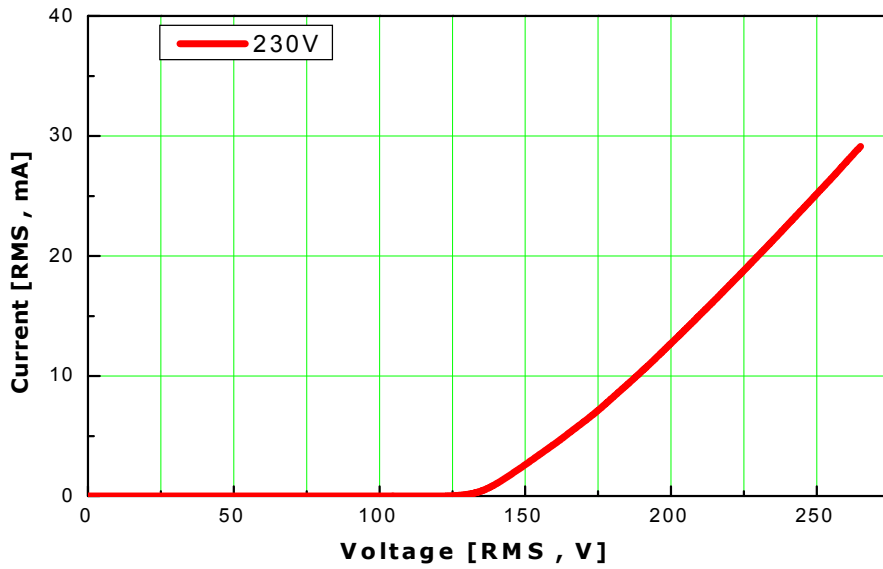

Voltage – Relative flux characteristics, Ta=25°C

1. AX3200 with external resistor @100V

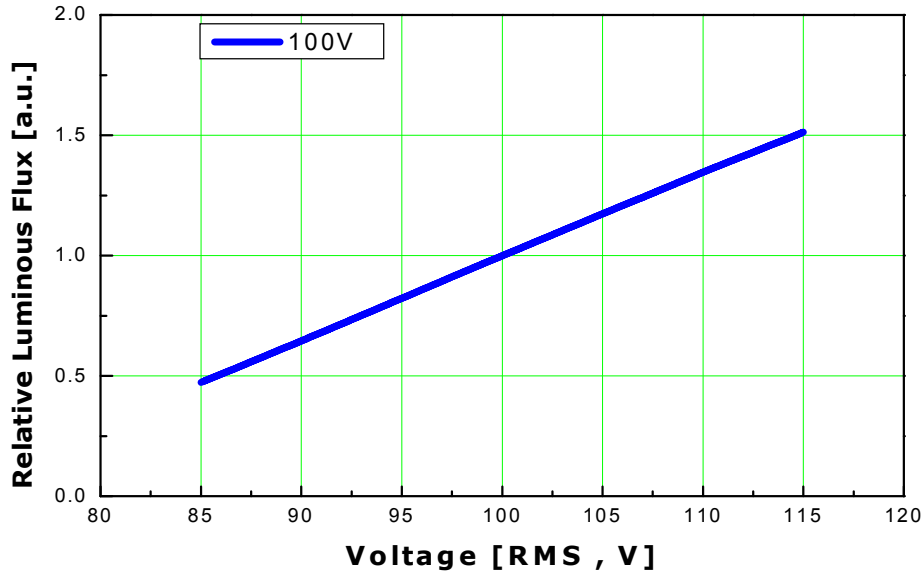

2. AX3200 with external resistor @110V

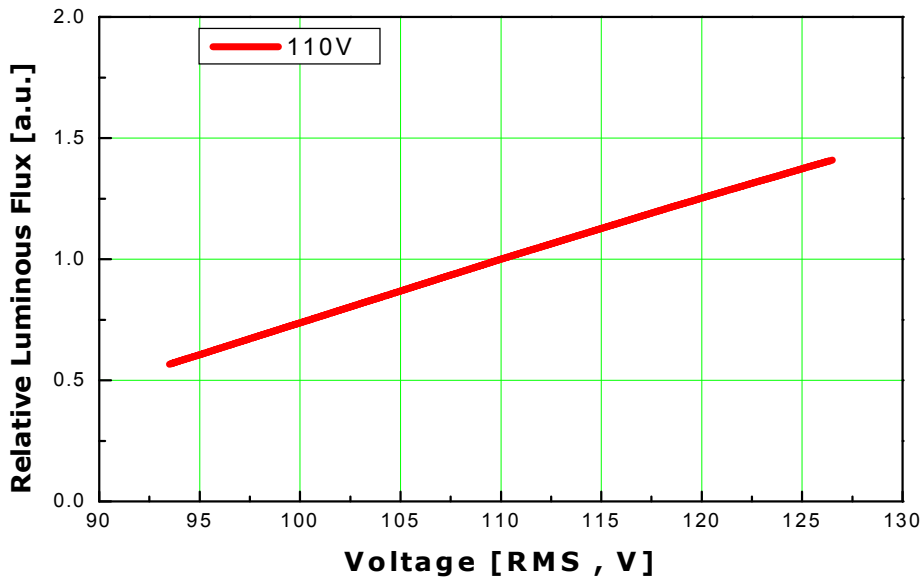

Voltage – Relative flux characteristics, Ta=25°C

3. AX3200 with external resistor @120V

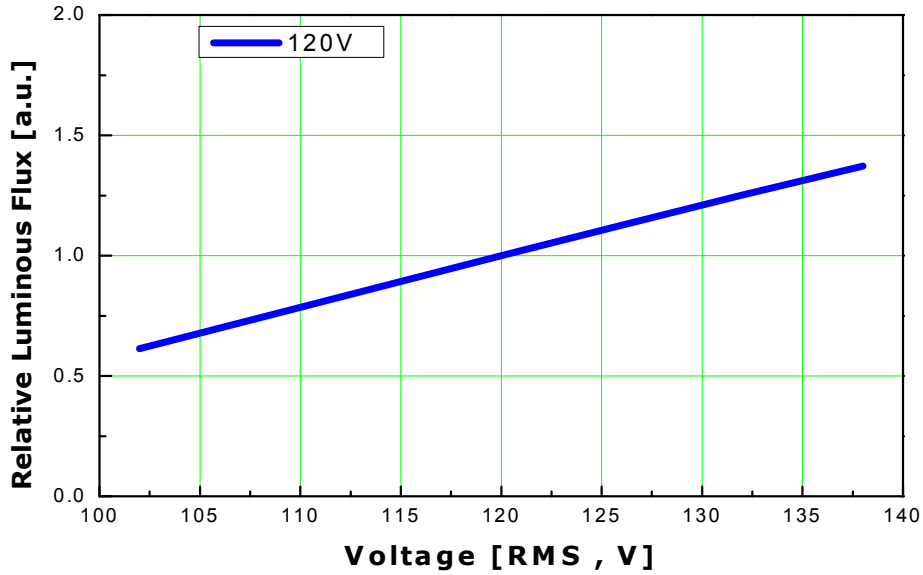

Voltage – Relative flux characteristics, Ta=25°C

4. AX3220 with external resistor @220V

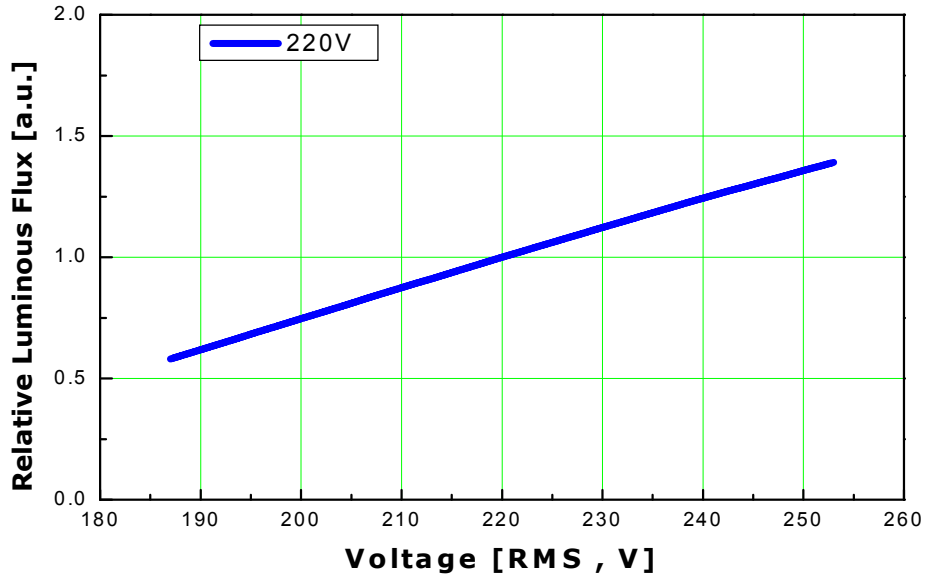

5. AX3220 with external resistor @230V

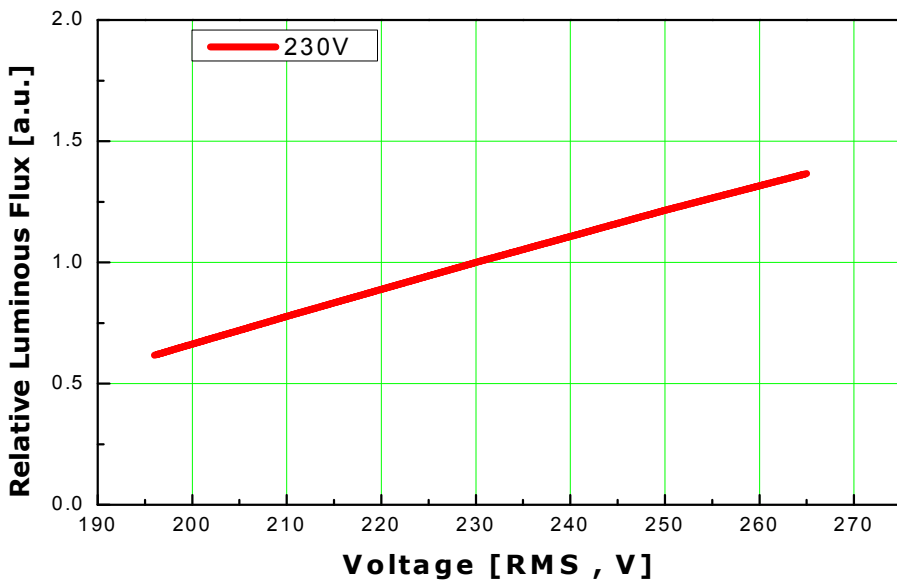

Relative Flux – Junction temperature characteristics

1. AX32X0

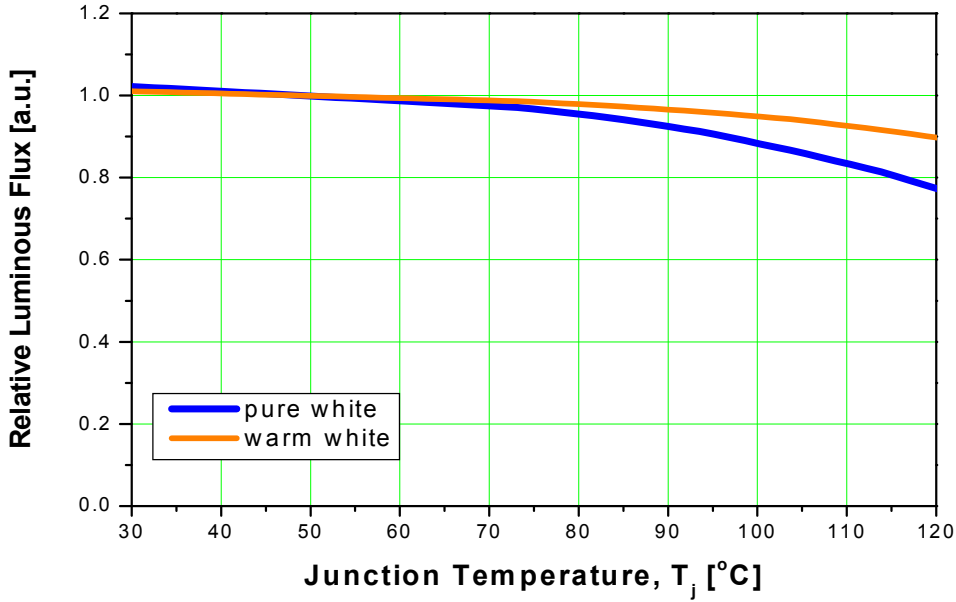

Typical dome type radiation pattern, $T_a=25^\circ\text{C}$

1. AX32X0

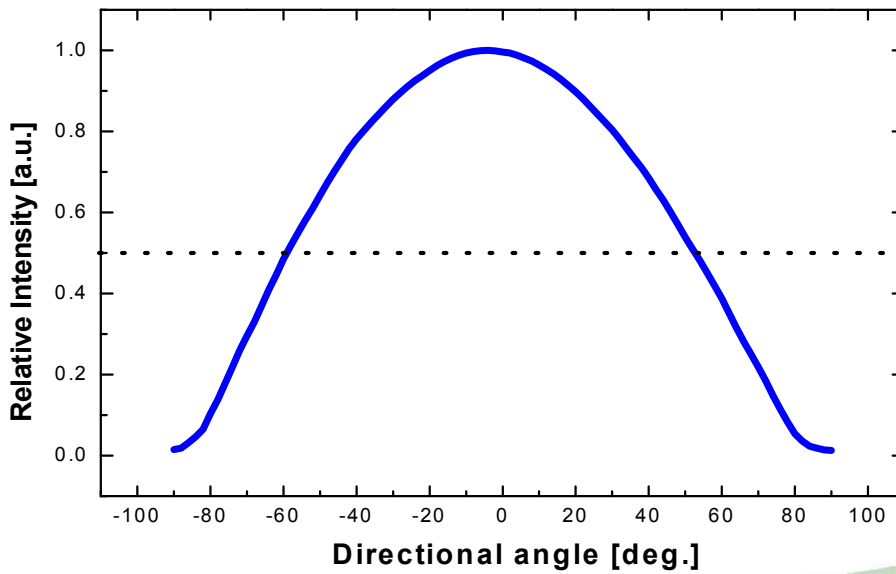

Acriche Binning structure graphical representation

1. AX32X0

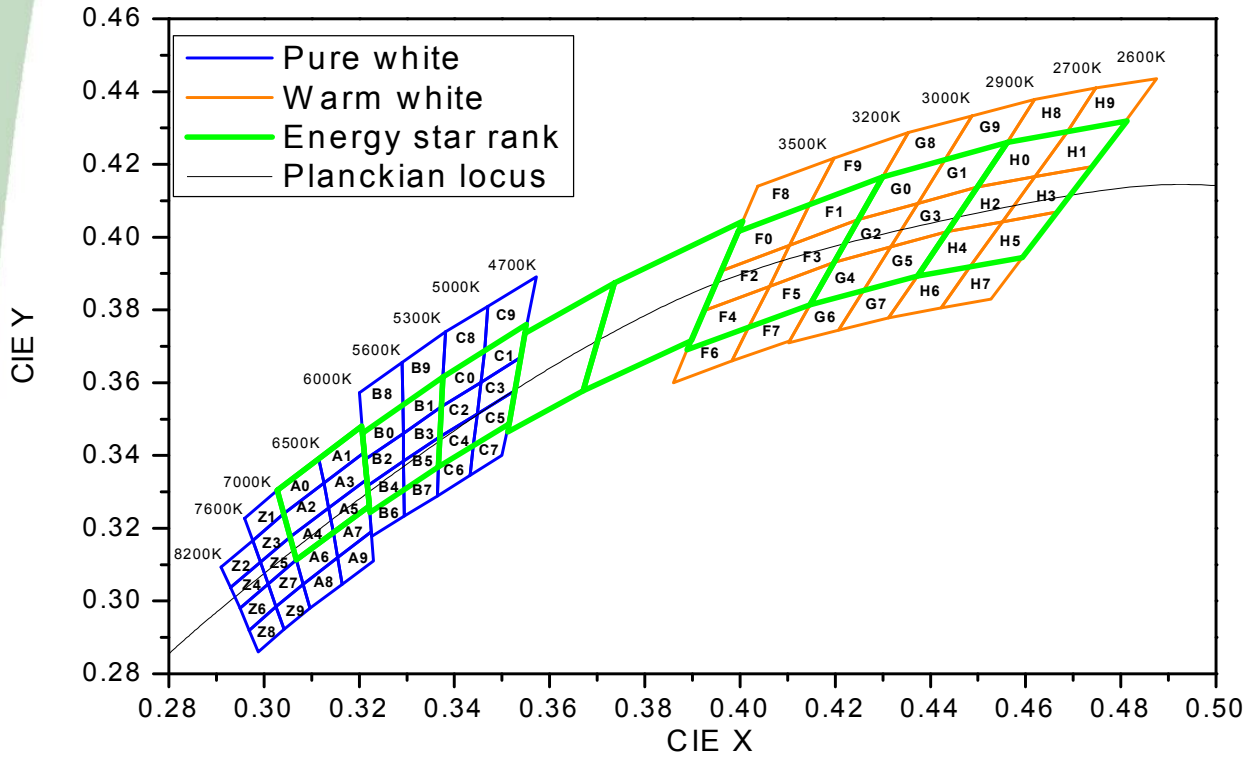

*Notes : For more detailed information on Acriche binning see the "Acriche Binning and Labeling" document at www.Acriche.com

Operating and biasing instructions of AX32X0

1. Operating circuit

Attention: see notes 1 through 4 below

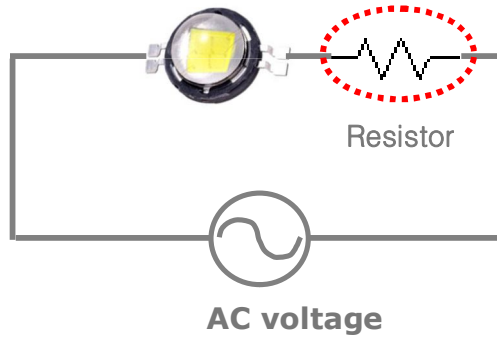

2. Resistor sheet

VF Bin	AX3200 [1]			AX3220 [1]		
	Drive current : 40mA [RMS] [2]			Drive current : 20mA [RMS] [2]		
	Resistor value [3] [4]			Resistor value [3] [4]		
	100V	110V	120V	220V	230V	240V
A	300Ω	500Ω	750Ω	2.2kΩ	2.6kΩ	3kΩ
B	250Ω	450Ω	700Ω	1.9kΩ	2.35kΩ	2.75kΩ
C	200Ω	400Ω	650Ω	1.63kΩ	2.1kΩ	2.55kΩ
D	-	350Ω	600Ω	1.36kΩ	1.85kΩ	2.3kΩ

Notes :

- [1] External resistor is required for proper Acriche biasing.
- [2] Drive current and voltage levels must not cause Acriche to operate outside Absolute Maximum Rating for power dissipation in table 1-2.
- [3] Drive current tolerance is ±10% on each resistor value.
- [4] Resistor power value must be taken into consideration when choosing the type of resistor.
[rated power = operating current² X resistance]

Operating and biasing instructions of AX32X0

3. Operating temperature



Lead Temperature (T_L)

Parameter	Value	Unit
R θ_{jL}	7	°C/W
T _j max	125	°C
T _L max	100	°C

4. Thermal modeling

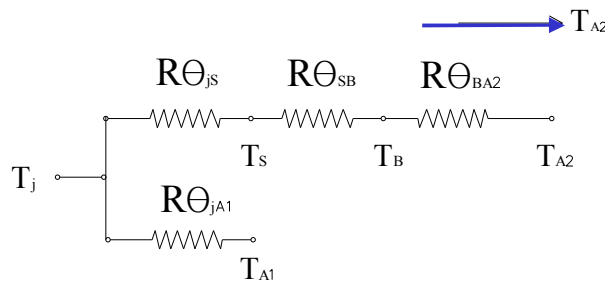
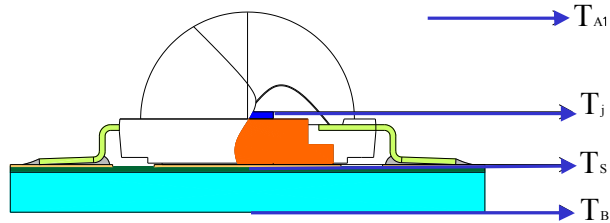

Notes :

- [1] Acrich must be used with proper heat management.
- [2] It is recommended that the temperature of board should be below 70 °C.
- [3] For more information, refer to Z Power led Thermal Management Guide.
(www.essc.co.kr/HOMEPAGE/home_kor/product/spec/thermal.pdf)

Operating and biasing instructions of AX32X0

5. Heat sink

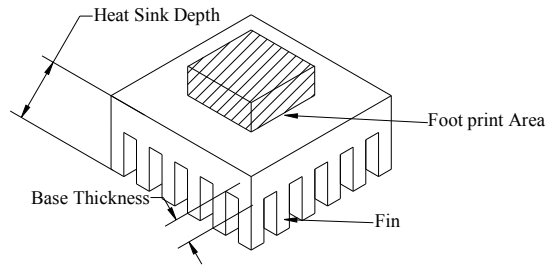
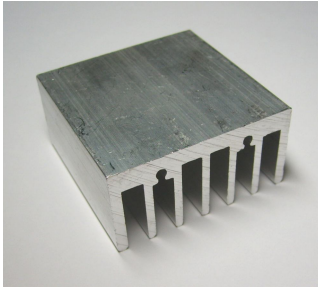

Specification & Size	T _B (°C)	R _{θBA} (°C /W)
Size : 44 x 44 mm S : 7mm T _B : 4mm, D _H : 22.mm F _H : 18mm N : 7ea Footprint: 745mm ² Power Dissipation:4W	73.8	10

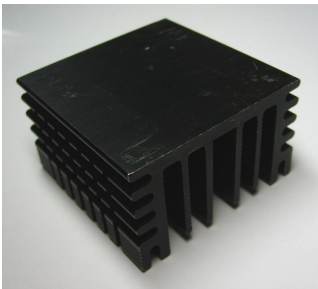

Specification & Size	T _B (°C)	R _{θBA} (°C /W)
Size : 50 x 50 mm S : T _B : mm, D _H : 25 mm F _H : mm N : Footprint: 745mm ² Power Dissipation:4W	56.2	5

Recommended solder pad

1. Solder pad

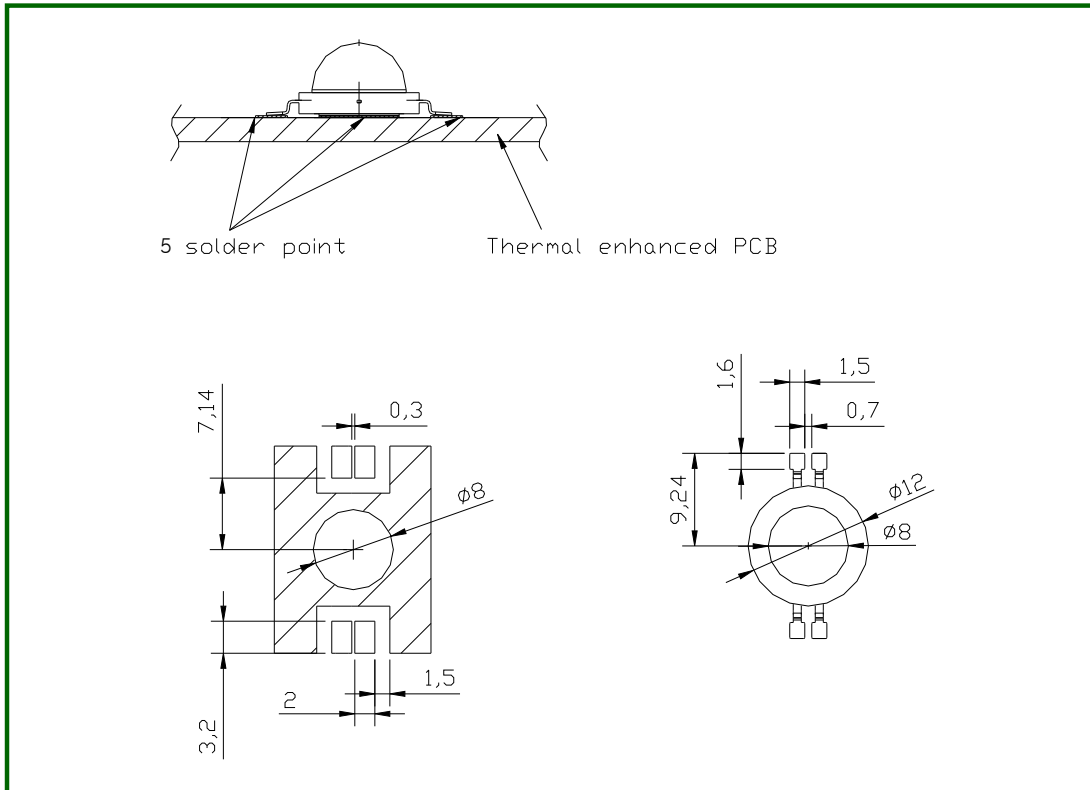

2. Solder paste pattern

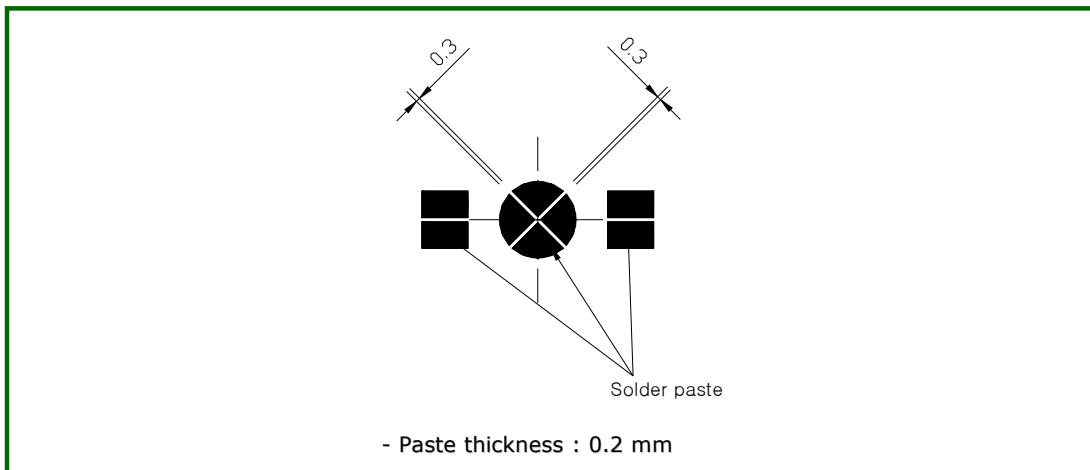

Solder profile

1. Reflow solder conditions / profile

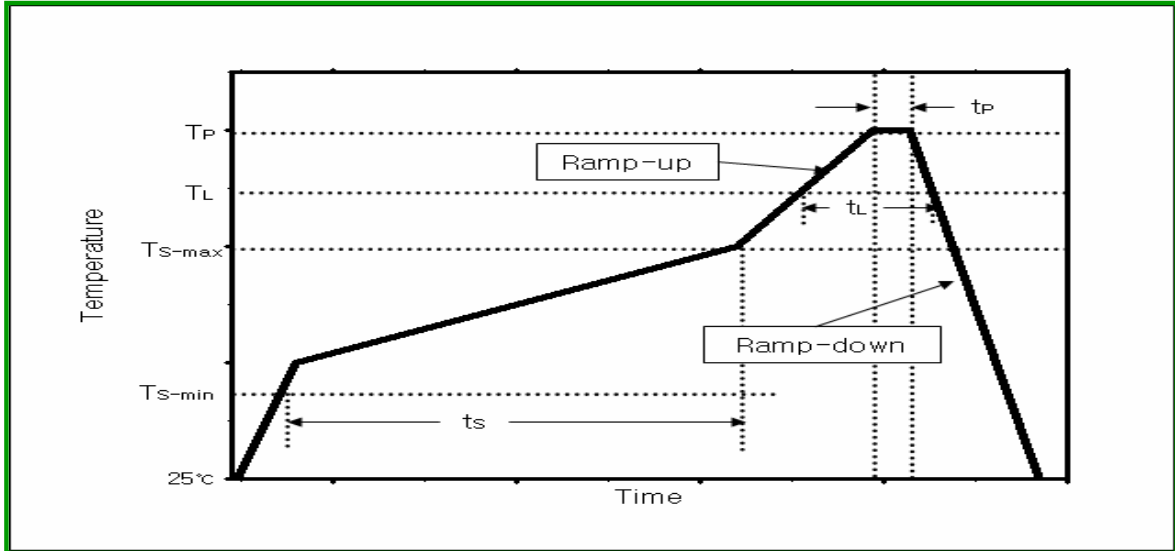

Reflow condition	Pb-Free assembly
Average ramp-up rate (TS-max to Peak)	2~3°C / second
Preheat Temperature Min (TS-min)	150°C
Preheat Temperature Max (TS-max)	200°C
Time maintained above: : Liquidus Temperature (TL)	217~220°C
Time maintained above: Time (tL)	60~150 seconds
Peak Temperature (TP)	250°C
Time within 5°C of actual Peak Temperature (tp)	20~40 seconds
ramp-down rate	4~6°C / second
Time 25°C to Peak Temperature	6 minutes max

2. Hand Solder conditions

- 2-1 Lead : Not more than 3 seconds @MAX280°C
- 2-2 Slug : Use a thermal adhesive

*** Caution**

- [1] Reflow soldering should not be done more than one time.
- [2] Repairs should not be done after the LED has been soldered to the board. If repairs are unavoidable, suitable tools must be used.
- [3] Die slug is to be soldered.
- [4] During the soldering process, do not put stress on the LED.
- [5] After soldering, do not warp or twist circuit board.
- [6] Recommend to use a convection type reflow machine with 7 ~ 8 zones. Rev. 08

September 2012

Emitter Reel Packaging

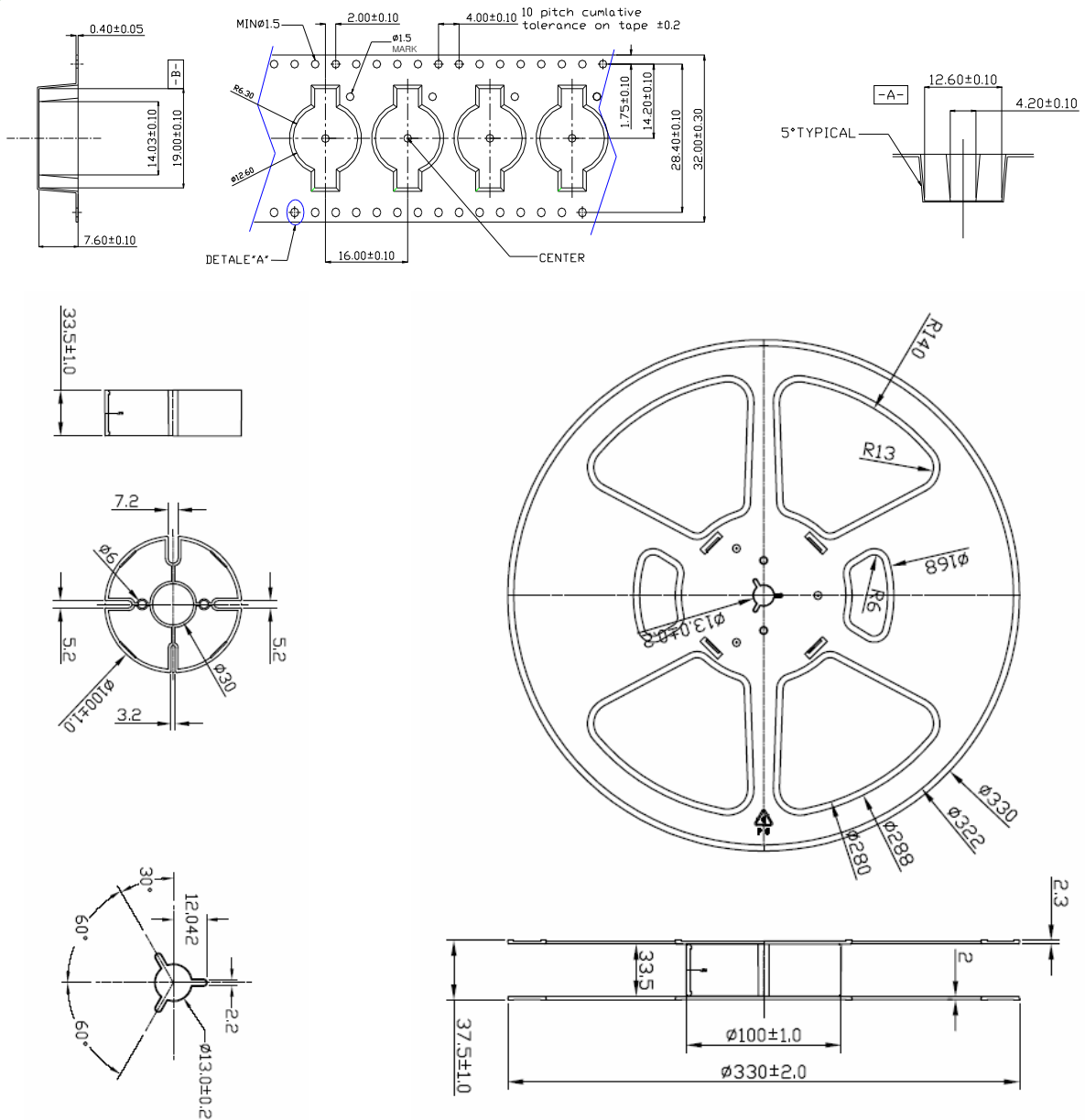

Note :

1. The number of loaded products in the reel is 250ea
2. All dimensions are in millimeters
3. Scale none

*The appearance and specifications of the product may be changed for improvement without notice.

Packaging Structure

Aluminum Vinyl Bag

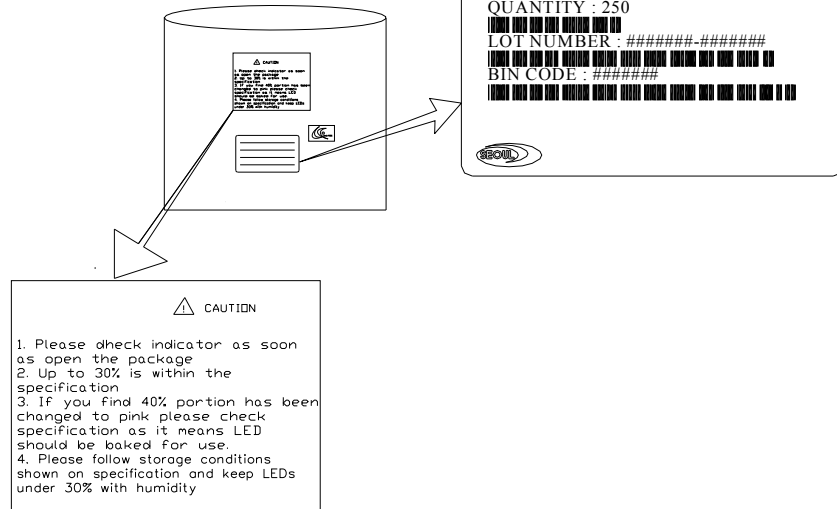

Outer Box

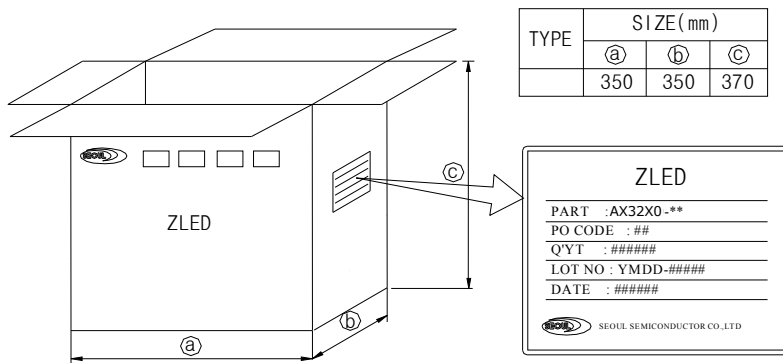

Note :

1. 6~10 reels are loaded in box
2. Scale none
3. For more information about binning and labeling, refer to the Application Note - 1

Precautions for use

- [1] Please note Acriche runs on high voltage so use caution when near the leads or if a dome is inadvertently removed while circuit is active
- [2] Please do not touch any of the circuit board, components or terminals with bare hands or metal while circuit is electrically active.
- [3] Please do not add or change wires while Acriche circuit is active

Handling of silicone resin for LEDs

- [1] Acriche series is encapsulated by silicone resin for the highest flux efficiency.
- [2] Avoid touching silicone resin portion of LED especially with sharp tools such as Pincette (tweezers).
- [3] Avoid leaving fingerprints on silicone resin parts.
- [4] Silicone resin is dust sensitive and needs a covered container for storage
- [5] When populating boards in SMT production there are no unusual restrictions regarding the form of the pick and place nozzle except that mechanical assure on the surface of the resin must be avoided.
- [6] Please do not apply diagonal force to the silicone lens in excess of 3000gf or permanent and fatal damage will occur.
- [7] Please do not cover the silicone resin with any other resin (epoxy, urethane, etc)



Компания «ЭлектроПласт» предлагает заключение долгосрочных отношений при поставках импортных электронных компонентов на взаимовыгодных условиях!

Наши преимущества:

- Оперативные поставки широкого спектра электронных компонентов отечественного и импортного производства напрямую от производителей и с крупнейших мировых складов;
- Поставка более 17-ти миллионов наименований электронных компонентов;
- Поставка сложных, дефицитных, либо снятых с производства позиций;
- Оперативные сроки поставки под заказ (от 5 рабочих дней);
- Экспресс доставка в любую точку России;
- Техническая поддержка проекта, помощь в подборе аналогов, поставка прототипов;
- Система менеджмента качества сертифицирована по Международному стандарту ISO 9001;
- Лицензия ФСБ на осуществление работ с использованием сведений, составляющих государственную тайну;
- Поставка специализированных компонентов (Xilinx, Altera, Analog Devices, Intersil, Interpoint, Microsemi, Aeroflex, Peregrine, Syfer, Eurofarad, Texas Instrument, Miteq, Cobham, E2V, MA-COM, Hittite, Mini-Circuits, General Dynamics и др.);

Помимо этого, одним из направлений компании «ЭлектроПласт» является направление «Источники питания». Мы предлагаем Вам помощь Конструкторского отдела:

- Подбор оптимального решения, техническое обоснование при выборе компонента;
- Подбор аналогов;
- Консультации по применению компонента;
- Поставка образцов и прототипов;
- Техническая поддержка проекта;
- Защита от снятия компонента с производства.



Как с нами связаться

Телефон: 8 (812) 309 58 32 (многоканальный)

Факс: 8 (812) 320-02-42

Электронная почта: org@eplast1.ru

Адрес: 198099, г. Санкт-Петербург, ул. Калинина, дом 2, корпус 4, литера А.