

NB3N121K

3.3V Differential 1:21 Fanout Clock and Data Driver with HCSL Outputs

Description

The NB3N121K is a differential 1:21 Clock and Data fanout buffer with High-speed Current Steering Logic (HCSL) outputs optimized for ultra low propagation delay variation. The NB3N121K is designed with HCSL PCI Express clock distribution and FBDIMM applications in mind.

Inputs can directly accept differential LVPECL, HCSL, and LVDS signals per Figures 7, 8, and 9. Single ended LVPECL, HCSL, LVCMOS, or LVTTTL levels are accepted with a proper external V_{th} reference supply per Figures 4 and 10. Input pins incorporate separate internal $50\ \Omega$ termination resistors allowing additional single ended system interconnect flexibility.

Output drive current is set by connecting a $475\ \Omega$ resistor from IREF (Pin 1) to GND per Figure 6. Outputs can also interface to LVDS receivers when terminated per Figure 11.

The NB3N121K specifically guarantees low output-to-output skew. Optimal design, layout, and processing minimize skew within a device and from device to device. System designers can take advantage of the NB3N121K's performance to distribute low skew clocks across the backplane or the motherboard.

Features

- Typical Input Clock Frequency 100, 133, 166, 200, 266, 333 and 400 MHz
- 340 ps Typical Rise and Fall Times
- 800 ps Typical Propagation Delay
- 100 ps Max Within Device Skew
- 150 ps Max Device-to-Device Skew
- Δt_{pd} 100 ps Maximum Propagation Delay Variation Per Each Differential Pair
- 0.1 ps Typical RMS Additive Phase Jitter
- LVDS Output Levels Optional with Interface Termination
- Operating Range: $V_{CC} = 3.0\text{ V to }3.6\text{ V}$ with $GND = 0\text{ V}$
- Typical HCSL Output Level (700 mV Peak-to-Peak)
- These are Pb-Free Devices

Applications

- Clock Distribution
- PCIe I, II, III
- Networking
- High End Computing
- Routers

End Products

- Servers
- FBDIMM Memory Card



ON Semiconductor®

<http://onsemi.com>

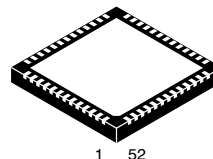

QFN-52
MN SUFFIX
CASE 485M

MARKING DIAGRAM*

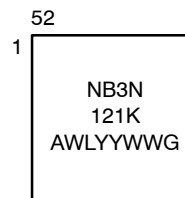

A = Assembly Site
WL = Wafer Lot
YY = Year
WW = Work Week
G = Pb-Free Package

*For additional marking information, refer to Application Note AND8002/D.

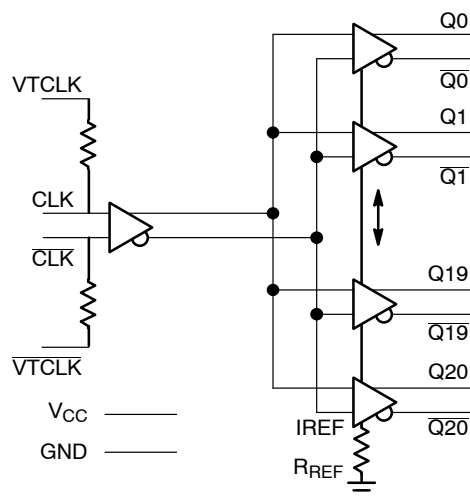

Figure 1. Simplified Logic Diagram

ORDERING INFORMATION

See detailed ordering and shipping information in the package dimensions section on page 10 of this data sheet.

NB3N121K

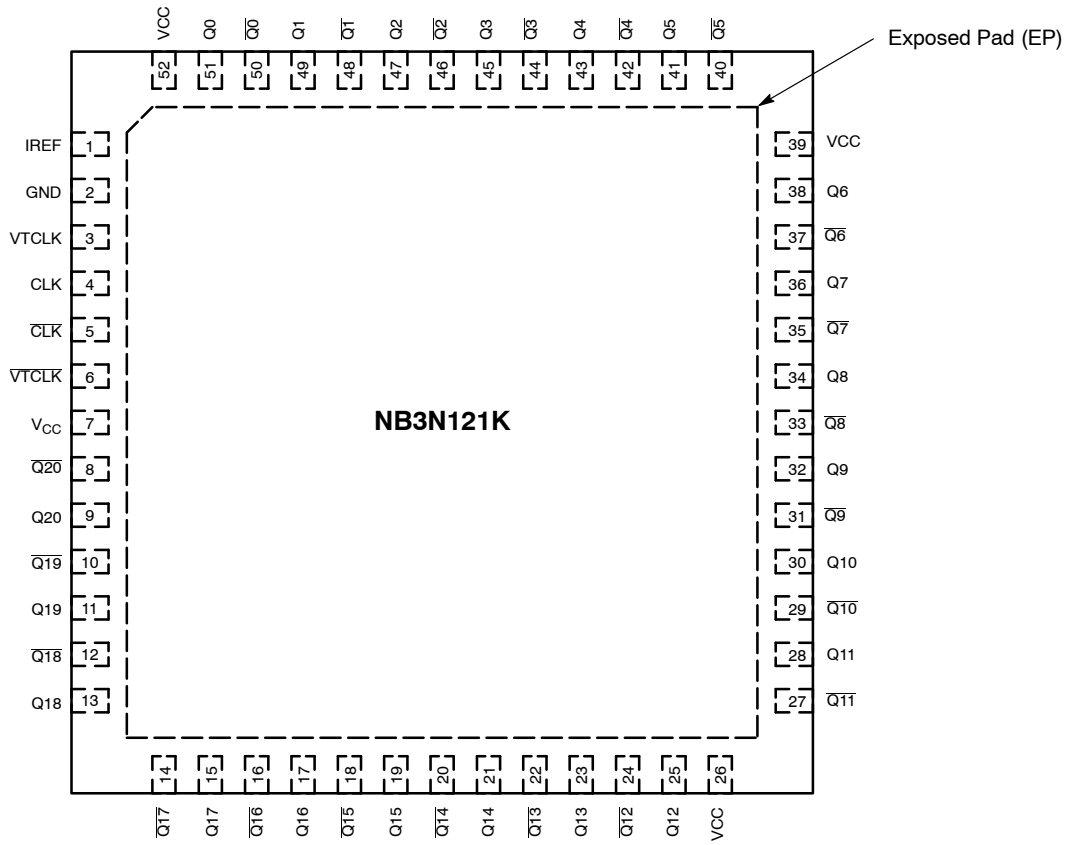

Figure 2. Pinout Configuration (Top View)

NB3N121K

Table 1. PIN DESCRIPTION

Pin	Name	I/O	Description
1	IREF	Output	Use the IREF pin to set the output drive. Connect a 475 Ω RREF resistor from the IREF pin to GND to produce 2.63 mA of IREF current. A current mirror multiplies IREF by a factor of 5.4 to force 14.2 mA through a 50 Ω output load. See Figures 6 and 12. Minimize capacitance.
2	GND	–	Supply Ground. GND pin must be externally connected to power supply to guarantee proper operation.
3, 6	VTCLK, VTCLK	–	Internal 50 Ω Termination Resistor connection Pins. In the differential configuration when the input termination pins are connected to the common termination voltage, and if no signal is applied then the device may be susceptible to self-oscillation.
4	CLK	LVPECL, HCSL, LVCMOS or LVTTTL Input	Clock (TRUE) Input
5	CLK	LVPECL, HCSL, LVCMOS or LVTTTL Input	Clock (INVERT) Input
7, 26, 39, 52	VCC	–	Positive Supply pins. VCC pins must be externally connected to a power supply to guarantee proper operation.
8, 10, 12, 14, 16, 18, 20, 22, 24, 27, 29, 31, 33, 35, 37, 40, 42, 44, 46, 48, 50	Q[20–0]	HCSL or LVDS (Note 1) Output	Output (INVERT) (Note 1)
9, 11, 13, 15, 17, 19, 21, 23, 25, 28, 30, 32, 34, 36, 38, 41, 43, 45, 47, 49, 51	Q[20–0]	HCSL or LVDS (Note 1) Output	Output (TRUE) (Note 1)
Exposed Pad	EP	GND	Exposed Pad. The thermally exposed pad (EP) on package bottom (see case drawing) must be attached to a sufficient heat-sinking conduit for proper thermal operation. The pad is electrically connected to GND and must be connected to GND on the PC board.

1. Outputs can also interface to LVDS receiver when terminated per Figure 11.

NB3N121K

Table 2. ATTRIBUTES

Characteristic		Value
ESD Protection	Human Body Model Machine Model	>2 kV 200 V
Moisture Sensitivity (Note 2)	QFN-52	Level 1
Flammability Rating	Oxygen Index: 28 to 34	UL 94 V-0 @ 0.125 in
Transistor Count		409
Meets or exceeds JEDEC Spec EIA/JESD78 IC Latchup Test		

2. For additional information, see Application Note AND8003/D.

Table 3. MAXIMUM RATINGS (Note 3)

Symbol	Parameter	Condition 1	Condition 2	Rating	Unit
V _{CC}	Positive Power Supply	GND = 0 V		4.6	V
V _I	Positive Input	GND = 0 V		GND - 0.3 ≤ V _I ≤ V _{CC}	V
I _{OUT}	Output Current	Continuous Surge		50 100	mA mA
T _A	Operating Temperature Range	QFN-52		-40 to +85	°C
T _{stg}	Storage Temperature Range			-65 to +150	°C
θ _{JA}	Thermal Resistance (Junction-to-Ambient) (Note 3)	0 lfpm 500 lfpm	QFN-52 QFN-52	25 19.6	°C/W °C/W
θ _{JC}	Thermal Resistance (Junction-to-Case)	2S2P (Note 4)	QFN-52	21	°C/W
T _{sol}	Wave Solder Pb-Free			265	°C

Stresses exceeding Maximum Ratings may damage the device. Maximum Ratings are stress ratings only. Functional operation above the Recommended Operating Conditions is not implied. Extended exposure to stresses above the Recommended Operating Conditions may affect device reliability.

3. JEDEC standard 51-6, multilayer board - 2S2P (2 signal, 2 power).

4. JEDEC standard multilayer board - 2S2P (2 signal, 2 power) with 8 filled thermal vias under exposed pad.

NB3N121K

Table 4. DC CHARACTERISTICS ($V_{CC} = 3.0\text{ V to }3.6\text{ V}$, $T_A = -40^\circ\text{C to }+85^\circ\text{C}$ Note 5)

Symbol	Characteristic	Min	Typ	Max	Unit
I_{GND}	GND Supply Current (All Outputs Loaded)		120	150	mA
I_{CC}	Power Supply Current (All Outputs Loaded)		440	500	mA
I_{IH}	Input HIGH Current		2.0	150	μA
I_{IL}	Input LOW Current	-150	-2.0		μA
R_{TIN}	Internal Input Termination Resistor	45	50	55	Ω

DIFFERENTIAL INPUT DRIVEN SINGLE – ENDED (See Figures 4 and 5)

V_{th}	Input Threshold Reference Voltage Range (Note 6)	350		$V_{CC} - 1000$	mV
V_{IH}	Single-Ended Input HIGH Voltage	$V_{th} + 150$		V_{CC}	mV
V_{IL}	Single-Ended Input LOW Voltage	GND		$V_{th} - 150$	mV

DIFFERENTIAL INPUTS DRIVEN DIFFERENTIALLY (Figures 7, 8 and 9)

V_{IHD}	Differential Input HIGH Voltage	425		$V_{CC} - 850$	mV
V_{ILD}	Differential Input LOW Voltage	GND		$V_{CC} - 1000$	mV
V_{ID}	Differential Input Voltage ($V_{IHD} - V_{ILD}$)	150		$V_{CC} - 850$	mV
V_{CMR}	Input Common Mode Range	350		$V_{CC} - 1000$	mV

HCSL OUTPUTS (Figure 4)

V_{OH}	Output HIGH Voltage	600	740	900	mV
V_{OL}	Output LOW Voltage	-150	0	150	mV

NOTE: Device will meet the specifications after thermal equilibrium has been established when mounted in a test socket or printed circuit board with maintained transverse airflow greater than 500 lfm. Electrical parameters are guaranteed only over the declared operating temperature range. Functional operation of the device exceeding these conditions is not implied. Device specification limit values are applied individually under normal operating conditions and not valid simultaneously.

- Measurements taken with with outputs loaded $50\ \Omega$ to GND. Connect a $475\ \Omega$ resistor from IREF (Pin 1) to GND. See Figure 6.
- V_{th} is applied to the complementary input when operating in single ended mode per Figure 4.

NB3N121K

Table 5. AC CHARACTERISTICS $V_{CC} = 3.0\text{ V to }3.6\text{ V}$, $GND = 0\text{ V}$; $-40^{\circ}\text{C to }+85^{\circ}\text{C}$ (Note 7)

Symbol	Characteristic	Min	Typ	Max	Unit
V_{OUTPP}	Output Voltage Amplitude (@ $V_{INPPmin}$) $f_{in} \leq 400\text{ MHz}$		725	1000	mV
t_{PLH} , t_{PHL}	Propagation Delay (See Figure 3a) CLK/ $\overline{\text{CLK}}$ to $Q_x/\overline{Q_x}$	550	800	950	ps
Δt_{PLH} , Δt_{PHL}	Propagation Delay Variations Per Each Diff Pair (Note 8) (See Figure 3a) CLK/ $\overline{\text{CLK}}$ to $Q_x/\overline{Q_x}$			100	ps
t_{SKEW}	Duty Cycle Skew (Note 9) Within -Device Skew Device to Device Skew (Note 10)			20 100 150	ps
t_{JIT}	Additive RMS Phase Jitter (Note 11) $F_{in} = 100\text{ MHz}$		0.1		ps
V_{INPP}	Input Voltage Swing/Sensitivity (Differential Configuration)	150		$V_{CC} - 850$	mV
V_{CROSS}	Absolute Crossing Magnitude Voltage (See Figure 3c)	250		550	mV
ΔV_{CROSS}	Variation in Magnitude of V_{CROSS} (See Figure 3c)			150	mV
t_r , t_f	Absolute Magnitude in Output Risetime and Falltime (from 175 mV to 525 mV) (See Figure 3b) $Q_x, \overline{Q_x}$	100	340	700	ps
Δt_r , Δt_f	Variation in Magnitude of Risetime and Falltime (Single-Ended) (See Figure 3b) $Q_x, \overline{Q_x}$			125	ps

NOTE: Device will meet the specifications after thermal equilibrium has been established when mounted in a test socket or printed circuit board with maintained transverse airflow greater than 500 lfm. Electrical parameters are guaranteed only over the declared operating temperature range. Functional operation of the device exceeding these conditions is not implied. Device specification limit values are applied individually under normal operating conditions and not valid simultaneously.

7. Measured by forcing V_{INPP} (MIN) from a 50% duty cycle clock source. Connect a 475 Ω resistor from IREF (Pin 1) to GND. All outputs loaded 50 Ω to GND per Figure 6.
8. Measured from the input pair crosspoint to each single output pair crosspoint across temp and voltage ranges per Figure 3.
9. Duty cycle skew is measured between differential outputs using the deviations of the sum of T_{pw-} and T_{pw+} .
10. Skew is measured between outputs under identical conditions @ 50 MHz.
11. Phase noise integrated from 12 kHz to 20 MHz

NB3N121K

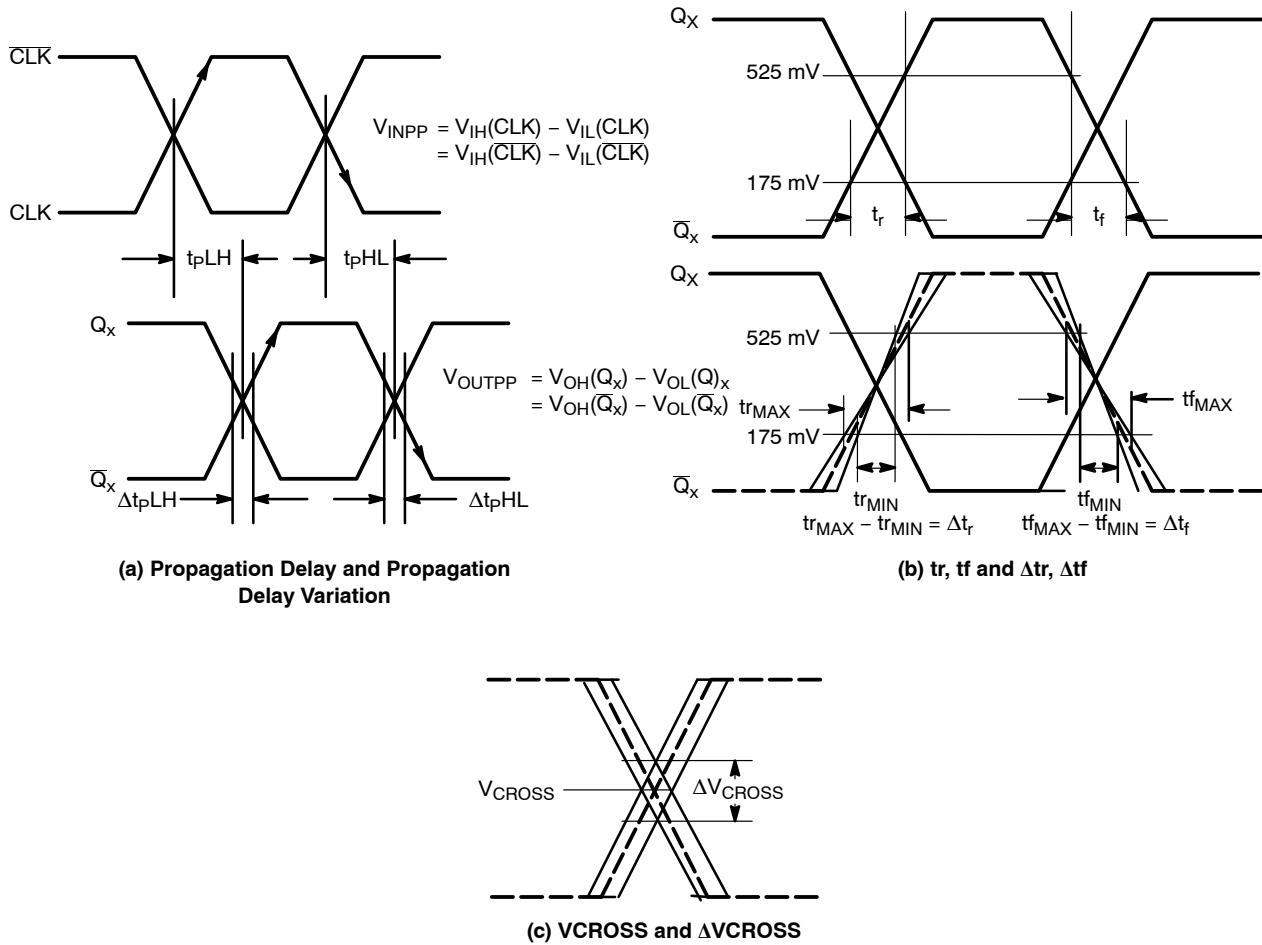

Figure 3. AC Reference Measurement

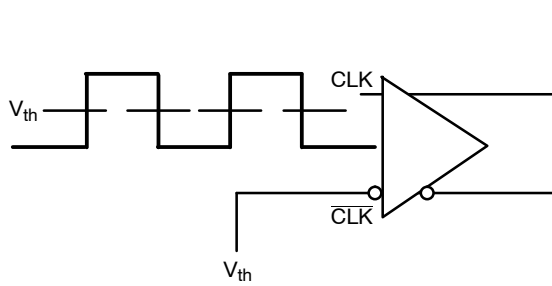

Figure 4. Single-Ended Interconnect V_{th} Reference Voltage

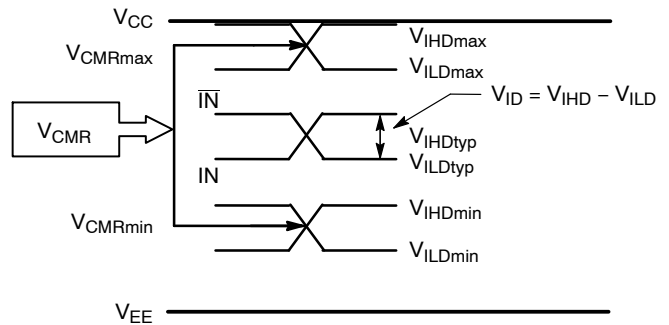
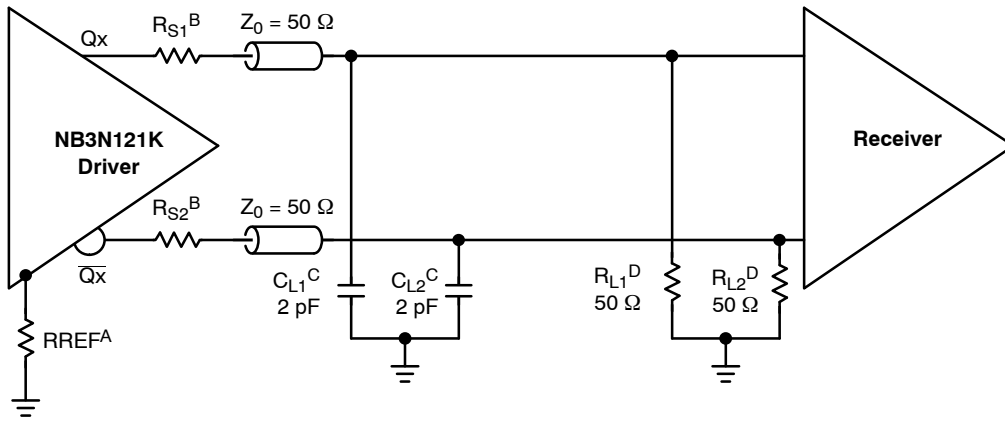

Figure 5. V_{th} Diagram

NB3N121K



- A. Connect 475 Ω resistor RREF from IREF pin to GND.
- B. R_{S1} , R_{S2} : 0 Ω for Test and Evaluation. Select to Minimizing Ringing.
- C. C_{L1} , C_{L2} : Receiver Input Simulation (for test only not added to application circuit).
- D. R_{L1} , R_{L2} Termination and Load Resistors Located at Receiver Inputs.

Figure 6. Typical Termination Configuration for Output Driver and Device Evaluation

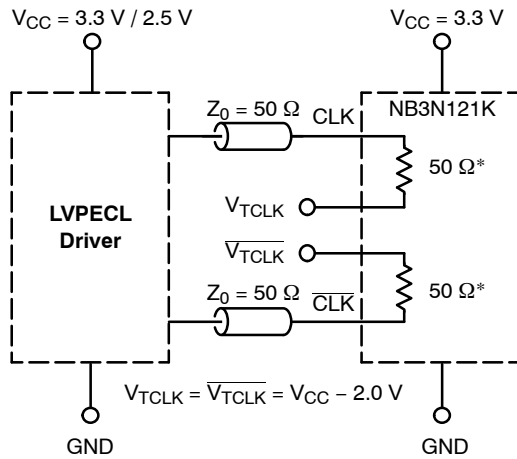

*RTIN, Internal Input Termination Resistor

Figure 7. LVPECL Interface

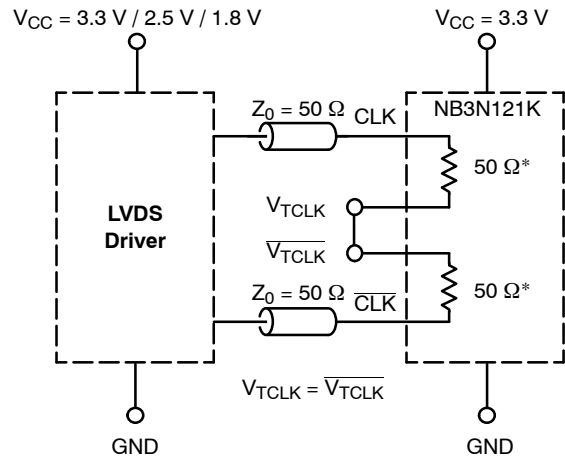

*RTIN, Internal Input Termination Resistor

Figure 8. LVDS Interface

NB3N121K

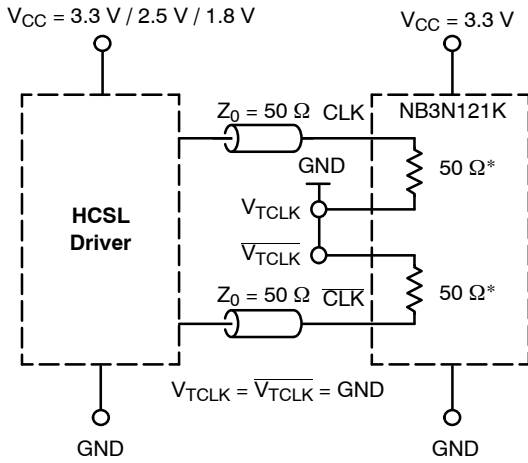

*RTIN, Internal Input Termination Resistor

Figure 9. Standard 50 Ω Load HCSL Interface

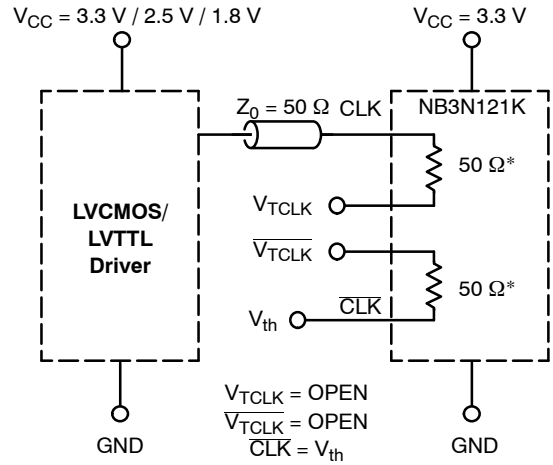

*RTIN, Internal Input Termination Resistor

Figure 10. LVCMOS/LVTTL Interface

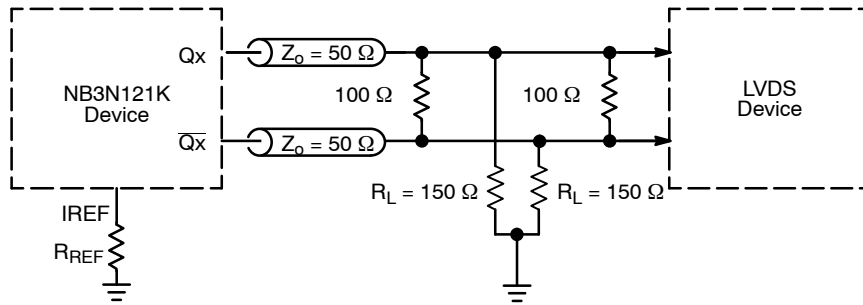

Figure 11. HCSL Interface Termination to LVDS

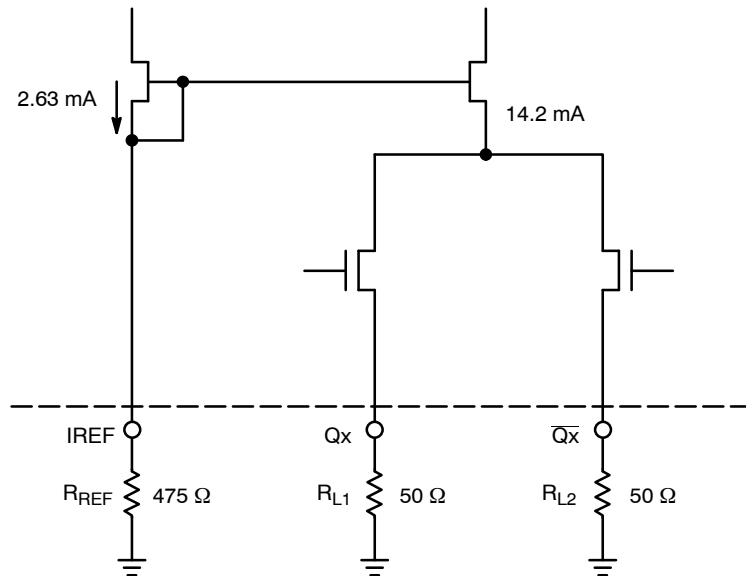

Figure 12. Simplified HCSL Output Structure

NB3N121K

ORDERING INFORMATION

Device	Package	Shipping†
NB3N121KMNG	QFN-52 (Pb-Free)	260 Units / Tray
NB3N121KMNR2G	QFN-52 (Pb-Free)	2000 / Tape & Reel

†For information on tape and reel specifications, including part orientation and tape sizes, please refer to our Tape and Reel Packaging Specifications Brochure, BRD8011/D.

NB3N121K

PACKAGE DIMENSIONS

QFN52 8x8, 0.5P
CASE 485M-01
ISSUE C

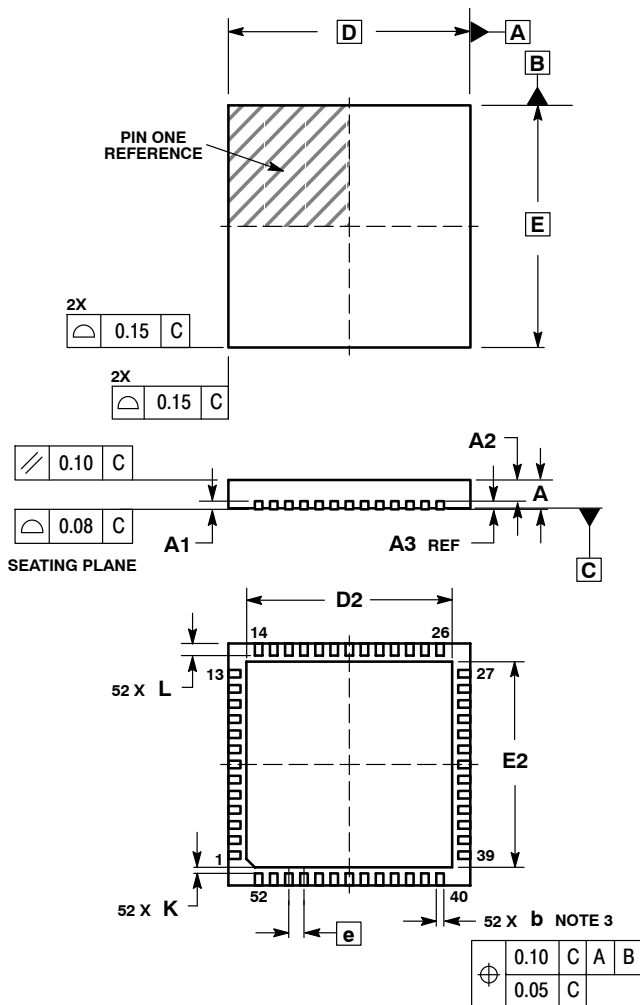

NOTES:

1. DIMENSIONING AND TOLERANCING PER ASME Y14.5M, 1994.
2. CONTROLLING DIMENSION: MILLIMETERS
3. DIMENSION b APPLIES TO PLATED TERMINAL AND IS MEASURED BETWEEN 0.25 AND 0.30 MM FROM TERMINAL.
4. COPLANARITY APPLIES TO THE EXPOSED PAD AS WELL AS THE TERMINALS.

DIM	MILLIMETERS	
	MIN	MAX
A	0.80	1.00
A1	0.00	0.05
A2	0.60	0.80
A3	0.20	REF
b	0.18	0.30
D	8.00	BSC
D2	6.50	6.80
E	8.00	BSC
E2	6.50	6.80
e	0.50	BSC
K	0.20	---
L	0.30	0.50

RECOMMENDED SOLDERING FOOTPRINT

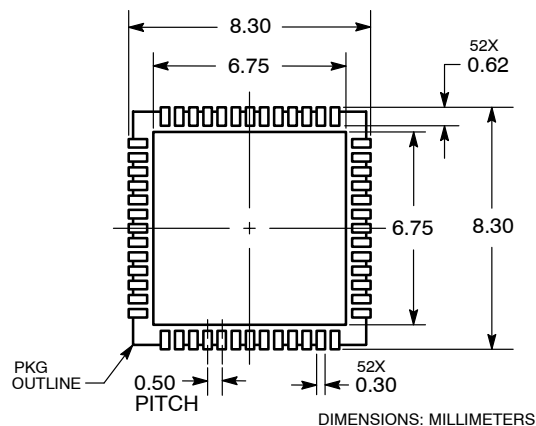

*For additional information on our Pb-Free strategy and soldering details, please download the ON Semiconductor Soldering and Mounting Techniques Reference Manual, SOLDERRM/D.

ON Semiconductor and are registered trademarks of Semiconductor Components Industries, LLC (SCILLC). SCILLC reserves the right to make changes without further notice to any products herein. SCILLC makes no warranty, representation or guarantee regarding the suitability of its products for any particular purpose, nor does SCILLC assume any liability arising out of the application or use of any product or circuit, and specifically disclaims any and all liability, including without limitation special, consequential or incidental damages. "Typical" parameters which may be provided in SCILLC data sheets and/or specifications can and do vary in different applications and actual performance may vary over time. All operating parameters, including "Typicals" must be validated for each customer application by customer's technical experts. SCILLC does not convey any license under its patent rights nor the rights of others. SCILLC products are not designed, intended, or authorized for use as components in systems intended for surgical implant into the body, or other applications intended to support or sustain life, or for any other application in which the failure of the SCILLC product could create a situation where personal injury or death may occur. Should Buyer purchase or use SCILLC products for any such unintended or unauthorized application, Buyer shall indemnify and hold SCILLC and its officers, employees, subsidiaries, affiliates, and distributors harmless against all claims, costs, damages, and expenses, and reasonable attorney fees arising out of, directly or indirectly, any claim of personal injury or death associated with such unintended or unauthorized use, even if such claim alleges that SCILLC was negligent regarding the design or manufacture of the part. SCILLC is an Equal Opportunity/Affirmative Action Employer. This literature is subject to all applicable copyright laws and is not for resale in any manner.

PUBLICATION ORDERING INFORMATION

LITERATURE FULFILLMENT:

Literature Distribution Center for ON Semiconductor
P.O. Box 5163, Denver, Colorado 80217 USA
Phone: 303-675-2175 or 800-344-3860 Toll Free USA/Canada
Fax: 303-675-2176 or 800-344-3867 Toll Free USA/Canada
Email: orderlit@onsemi.com

N. American Technical Support: 800-282-9855 Toll Free
USA/Canada
Europe, Middle East and Africa Technical Support:
Phone: 421 33 790 2910
Japan Customer Focus Center
Phone: 81-3-5817-1050

ON Semiconductor Website: www.onsemi.com

Order Literature: <http://www.onsemi.com/orderlit>

For additional information, please contact your local Sales Representative



Компания «ЭлектроПласт» предлагает заключение долгосрочных отношений при поставках импортных электронных компонентов на взаимовыгодных условиях!

Наши преимущества:

- Оперативные поставки широкого спектра электронных компонентов отечественного и импортного производства напрямую от производителей и с крупнейших мировых складов;
- Поставка более 17-ти миллионов наименований электронных компонентов;
- Поставка сложных, дефицитных, либо снятых с производства позиций;
- Оперативные сроки поставки под заказ (от 5 рабочих дней);
- Экспресс доставка в любую точку России;
- Техническая поддержка проекта, помощь в подборе аналогов, поставка прототипов;
- Система менеджмента качества сертифицирована по Международному стандарту ISO 9001;
- Лицензия ФСБ на осуществление работ с использованием сведений, составляющих государственную тайну;
- Поставка специализированных компонентов (Xilinx, Altera, Analog Devices, Intersil, Interpoint, Microsemi, Aeroflex, Peregrine, Syfer, Eurofarad, Texas Instrument, Miteq, Cobham, E2V, MA-COM, Hittite, Mini-Circuits, General Dynamics и др.);

Помимо этого, одним из направлений компании «ЭлектроПласт» является направление «Источники питания». Мы предлагаем Вам помощь Конструкторского отдела:

- Подбор оптимального решения, техническое обоснование при выборе компонента;
- Подбор аналогов;
- Консультации по применению компонента;
- Поставка образцов и прототипов;
- Техническая поддержка проекта;
- Защита от снятия компонента с производства.



Как с нами связаться

Телефон: 8 (812) 309 58 32 (многоканальный)

Факс: 8 (812) 320-02-42

Электронная почта: org@eplast1.ru

Адрес: 198099, г. Санкт-Петербург, ул. Калинина, дом 2, корпус 4, литера А.