



<i>Product Specification</i>	<i>Model:</i>	AWT-320240T35P02	<i>Rev. No.</i>	<i>Issued Date.</i>	<i>Page.</i>
			A	2012/03/05	1 / 21

**LIQUID CRYSTAL DISPLAY MODULE**  
**MODEL: AWT-320240T35P02**  
**Customer's No.:**

Acceptance

10-1 Floor, No.192, Tahtung Road,  
 Sec. 3, Hsi-Chih City,  
 Taipei Hsien, Taiwan

Approved and Checked by

Approved by	Checked by		Made by
 榉 叡 2009/11/23 NICK	 榉 叡 2009/11/23 JOE		 榉 叡 2009/11/23 TOM

<i>Product Specification</i>	<i>Model:</i>	<i>AWT-320240T35P02</i>	<i>Rev. No.</i>	<i>Issued Date.</i>	<i>Page.</i>
			A	2012/03/05	2 / 21

## Contents

1. General Description.....	3
2. Physical Features.....	3
3. Mechanical Specification.....	3
4. Outline Dimension.....	4
5. Absolute Maximum Ratings .....	5
6. Electrical Characteristics.....	5
7. Module Function Description.....	6
8. Backlight Characteristics .....	9
9. Electro-Optical Characteristics .....	10
10. Reliability.....	12
11. Inspection Standards.....	13
12. Precautions For Using LCD Modules .....	19
13. Records Of Version .....	21

<i>Product Specification</i>	<i>Model:</i>	AWT-320240T35P02	<i>Rev. No.</i>	<i>Issued Date.</i>	<i>Page.</i>
			A	2012/03/05	3 / 21

## 1. General Description

AWT-320240T35P02 is a transmissive type a-Si TFT-LCD (amorphous silicon thin film transistor liquid crystal display) module, which is composed of a TFT-LCD panel, a driver circuit and a backlight unit. The panel size is 3.5 inch and the resolution is 320x240, the panel can display up to 262K colors. The LCM can be easily accessed by micro-controller via parallel interface.

## 2. Physical Features

Display Mode	TFT-LCD Module
	Active matrix TFT, Transmissive type
Display Format	Graphic 320×RGB×240 Dot-matrix
Input Data	24 bit RGB with Serial Interface\CCIR656
Viewing Direction	6 O'clock
Drive	HX8238-A

## 3. Mechanical Specification

Item	Contents	Unit
Module size (W×H×T)	63.9 × 76.9 × 4.4	mm
Number of dots	320(RGB) × 240	---
Active area (W×H)	70.08 × 52.56	mm

Product Specification	Model:	AWT-320240T35P02	Rev. No.	Issued Date.	Page.
			A	2012/03/05	4 / 21

# 4.Outline

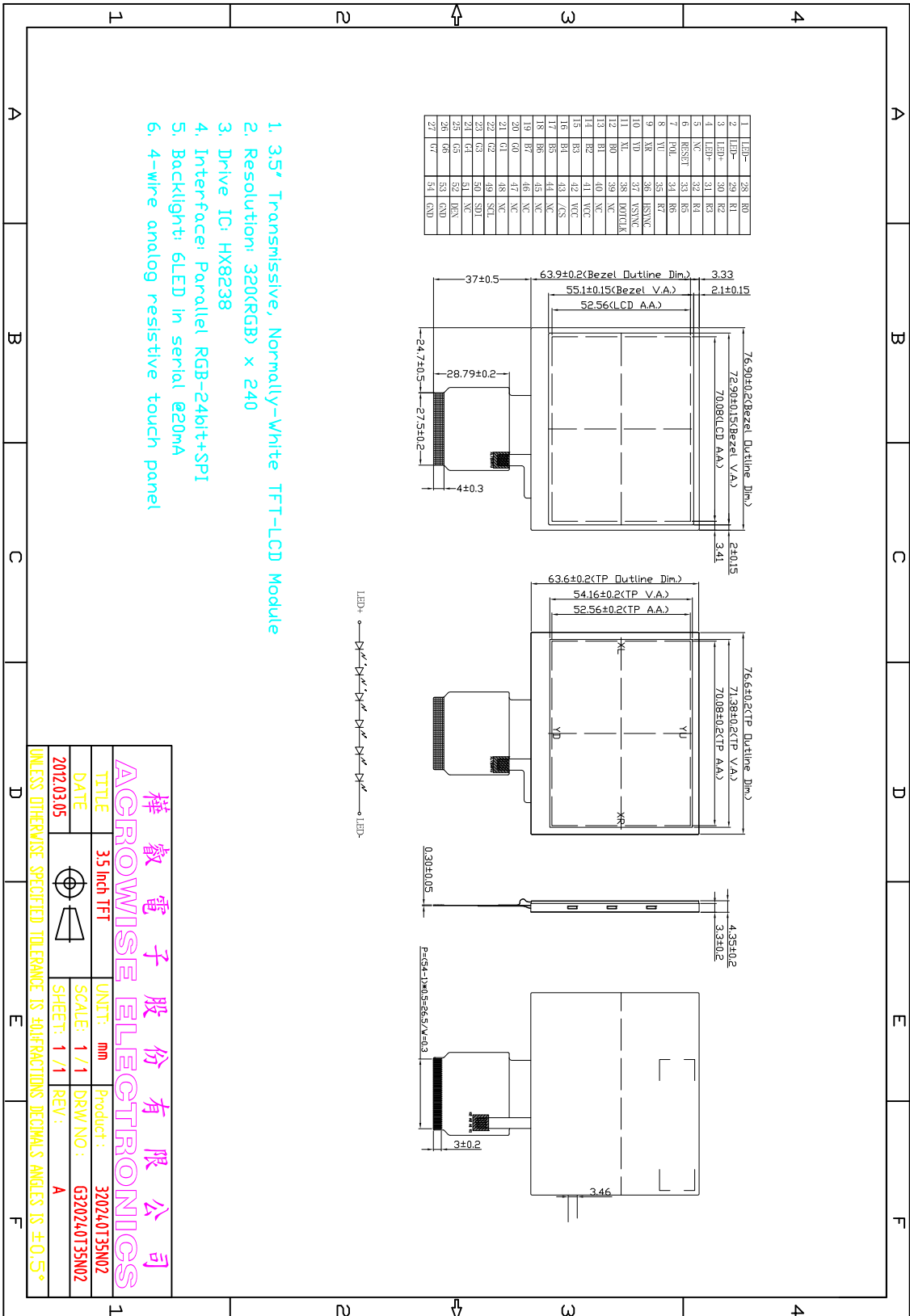

Product Specification	Model:	AWT-320240T35P02	Rev. No.	Issued Date.	Page.
			A	2012/03/05	5 / 21

## 5. Absolute Maximum Ratings

Item	Symbol	Min	Max	Unit	Remark
Power Voltage	VCC	-0.3	3.6	V	Note1、 Note2
Input Voltage	VIN	-0.3	VCC+0.3	V	
Operating temperature	TOPR	-20	70	°C	
Storage temperature	TSTR	-30	80	°C	
Humidity	---	---	90	%RH	---

Remark:

Note 1) The HX8238 may be permanently damaged if it is used under the condition exceeding the above absolute maximum values. It is also recommended to use the HX8238 within the limit of its electric characteristics during normal operation. Exceeding the conditions may lead to malfunction of HX8238 and affect its credibility.

Note 2) The voltage from VSS.

## 6. Electrical Characteristics

Item		Symbol	Rating			Unit	Remark
			Min	Typ	Max		
Power Voltage	Logic	VCC	2.5	3.3	3.6	V	Note1
Input Voltage	L level	VIL	-0.3	---	0.2*VCC	V	VCC=2.5 ~ 3.6V
	H level	VIH	0.8* VCC	---	---	V	
LCD Drive Power current		ILCD	---	---	15	mA	---

Remark:

Note1:Vcom must be adjusted to optimize display quality: Cross-talk, Contrast Ratio and etc.

Product Specification	Model:	AWT-320240T35P02	Rev. No.	Issued Date.	Page.
			A	2012/03/05	6 / 21

## 7. Module Function Description

### 7-1. Block Diagram Of LCM

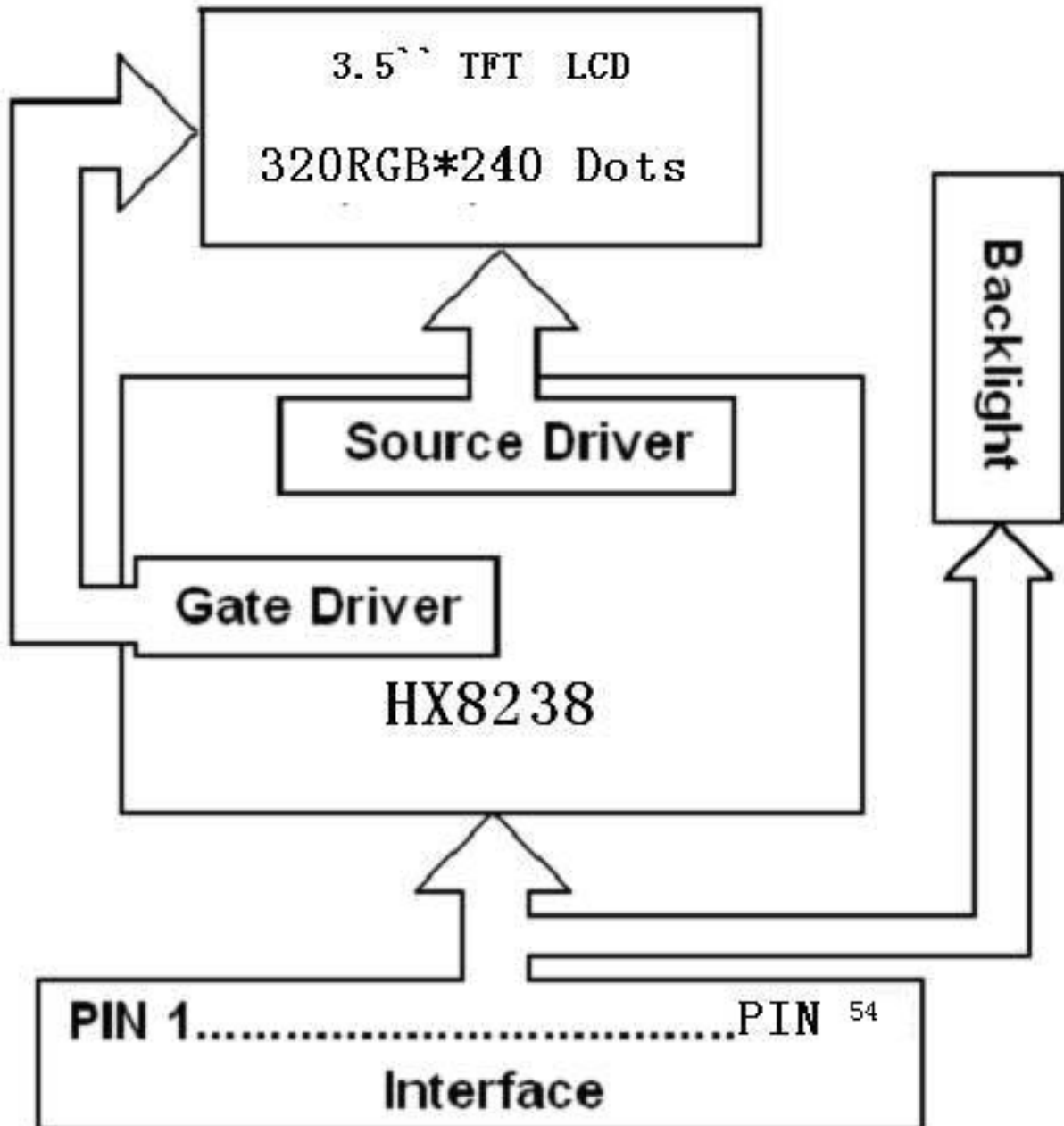

<i>Product Specification</i>	<i>Model:</i>	AWT-320240T35P02	<i>Rev. No.</i>	<i>Issued Date.</i>	<i>Page.</i>
			A	2012/03/05	7 / 21

## 7-2. Pin Description

NO.	Symbol	Function
1-2	LED-K	CATHODE OF BACKLIGHT LED
3-4	LED-A	ANODE OF BACKLIGHT LED
5	NC	DUMMY PIN
6	/RESET	SYSTEM Reset
7	NC	DUMMY PIN
8	YU	TOUCH PANEL PINS
9	XR	
10	YD	
11	XL	
12-35	DB00-DB23	PARALLE RGB Data BUS
36	HSYNC	Line synchronization signal
37	VSYNC	Frame synchronization signal
38	DCLK	DOTCLK
39	NC	DUMMY PINS
40	NC	DUMMY PINS
41	VCC	SYSTEM VCC
42	VCC	SYSTEM VCC
43	SPENA	SPI ENABLE
44-47	NC	DUMMY PINS
48	GND	SYSTEM GND
49	SPCLK	SERIAL CLOCK SIGNAL
50	SPDAT	SERIAL DATA SIGNAL
51	NC	DUMMY PINS
52	DEN	Display enable pin from controller
53	GND	SYSTEM GND
54	GND	SYSTEM GND

Product Specification	Model:	AWT-320240T35P02	Rev. No.	Issued Date.	Page.
			A	2012/03/05	8 / 21

## 7-3. Timing Characteristics

### 7.3.1 RGB Interface Timing Characteristics

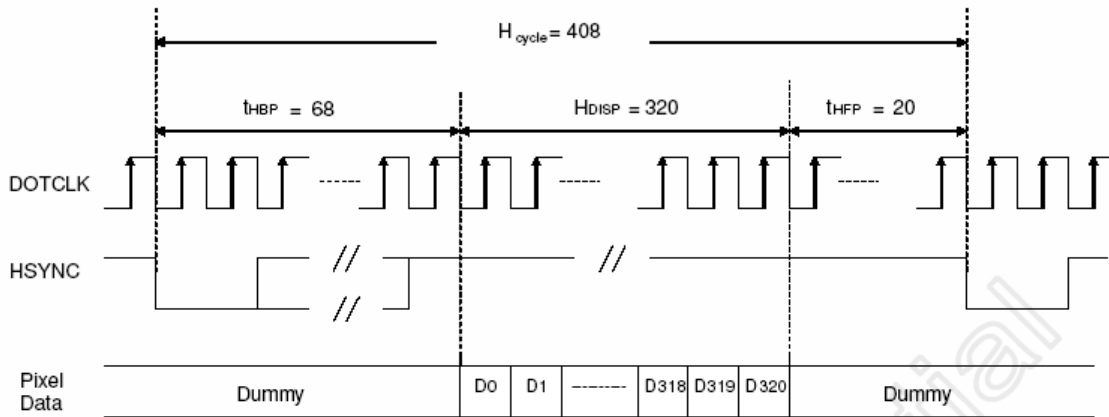

a) Horizontal Data Transaction Timing

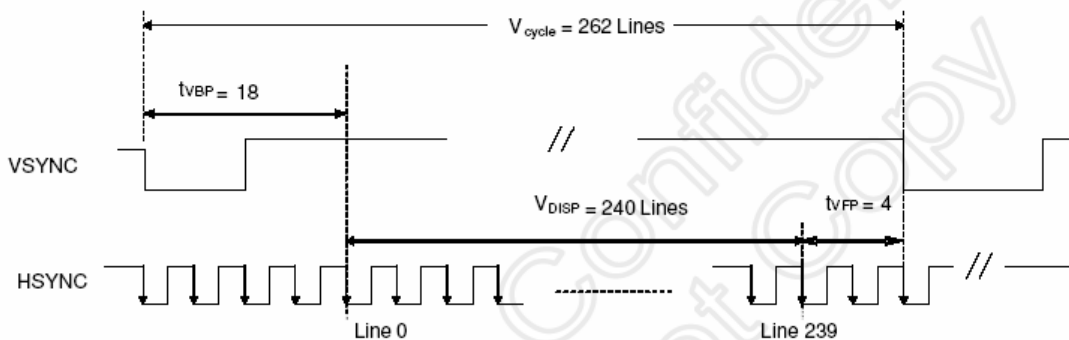

VCC=2.5~3.3V , Ta=25°C

Signal	Symbol	Parameter	Min.	Max.	Unit	description
RS	t <sub>AST</sub>	Address setup time	10	-	ns	-
	t <sub>AHT</sub>	Address hold time	10	-		
/CS	t <sub>CHW</sub>	Chip select 'H' pulse width	0	-	ns	-
	t <sub>TCS</sub>	Chip select setup time	35	-		
	t <sub>RCSFM</sub>	Chip select setup time	355	-		
	t <sub>CSF</sub>	Chip select wait time	10	-		
	t <sub>CSH</sub>	Chip select hold time	10	-		
/WR	t <sub>WC</sub>	Write cycle	100	-	ns	-
	t <sub>WRH</sub>	Control pulse 'H' duration	35	-		
	t <sub>WRL</sub>	Control pulse /L/ duration	35	-		
/RD	t <sub>RCFM</sub>	Read cycle	450	-	ns	When read from GRAM.
	t <sub>RDHFM</sub>	Control pulse 'H' duration	90	-		
	t <sub>RDLFM</sub>	Control pulse 'L' duration	355	-		
DB0~15	t <sub>DST</sub>	Data setup time	15	-	ns	-
	t <sub>DHT</sub>	Data hold time	10	-		
	t <sub>RATFM</sub>	Read access time	-	340		
	t <sub>ODH</sub>	Output disable time	20	80		



Product Specification	Model:	AWT-320240T35P02	Rev. No.	Issued Date.	Page.
			A	2012/03/05	9/21

## 8. Backlight Characteristics

Item	Symbol	Min	Typ	Max	Unit	Remark
Forward voltage	V <sub>BL</sub>	18	19.2	20	V	-
Current	I <sub>BL</sub>	-	15	-	mA/chip	-
ICE	X	0.26	-	0.32	-	-
	Y	0.26	-	0.32	-	-
Brightness	-	2600	-	-	cd/m <sup>2</sup>	★1
Uniformity	-	80	-	-	%	★2

★1 Test condition is :

- (a) Center point on active area
- (b) Best Contrast

★2 Uniform measure condition :

- (1) Measure 9 point. Measure location is show below :
- (2) Uniform = (Min. brightness / Max. brightness) × 100%
- (3) Best Contrast.

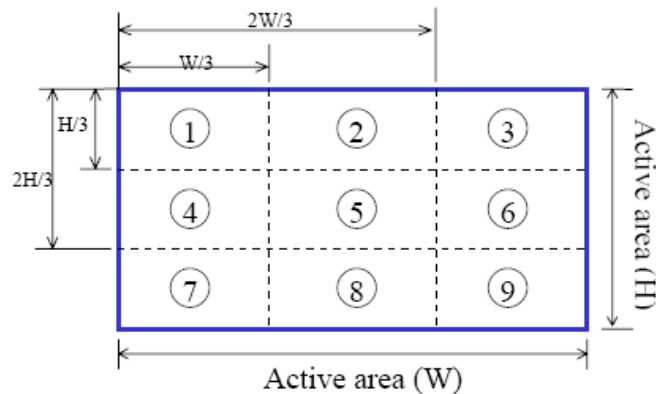

Product Specification	Model:	AWT-320240T35P02	Rev. No.	Issued Date.	Page.
			A	2012/03/05	10 / 21

## 9. Electro-Optical Characteristics

Item		Symbol	Condition	Min.	Typ.	Max.	Unit	Remark
Response time		Tr +Tf		---	50	70	ms	Reference Only
Contrast Ratio		CR		150	250	---	---	
Transmittance		T%		---	6.3	---	%	
Color chromaticity	white	Wx	$\theta_x = \theta_y = 0$	0.264	0.294	0.324	-	
		Wy		0.304	0.334	0.364		
	Red	Rx		0.603	0.633	0.663		
		Ry		0.296	0.326	0.356		
	Green	Gx		0.267	0.297	0.327		
		Gy		0.547	0.577	0.607		
Blue	Bx	0.103	0.133	0.163				
	By	0.099	0.129	0.159				
Viewing angle	Hor.	$\theta_{x+}$	CR $\geq 10$	50	60	---	Deg.	
		$\theta_{x-}$		50	60	---		
	Ver.	$\theta_{y+}$		40	50	---		
		$\theta_{y-}$		45	55	---		
Brightness		---	---	160	200	---	cd/m <sup>2</sup>	

Note (1) Definition of Viewing Angle x and y:

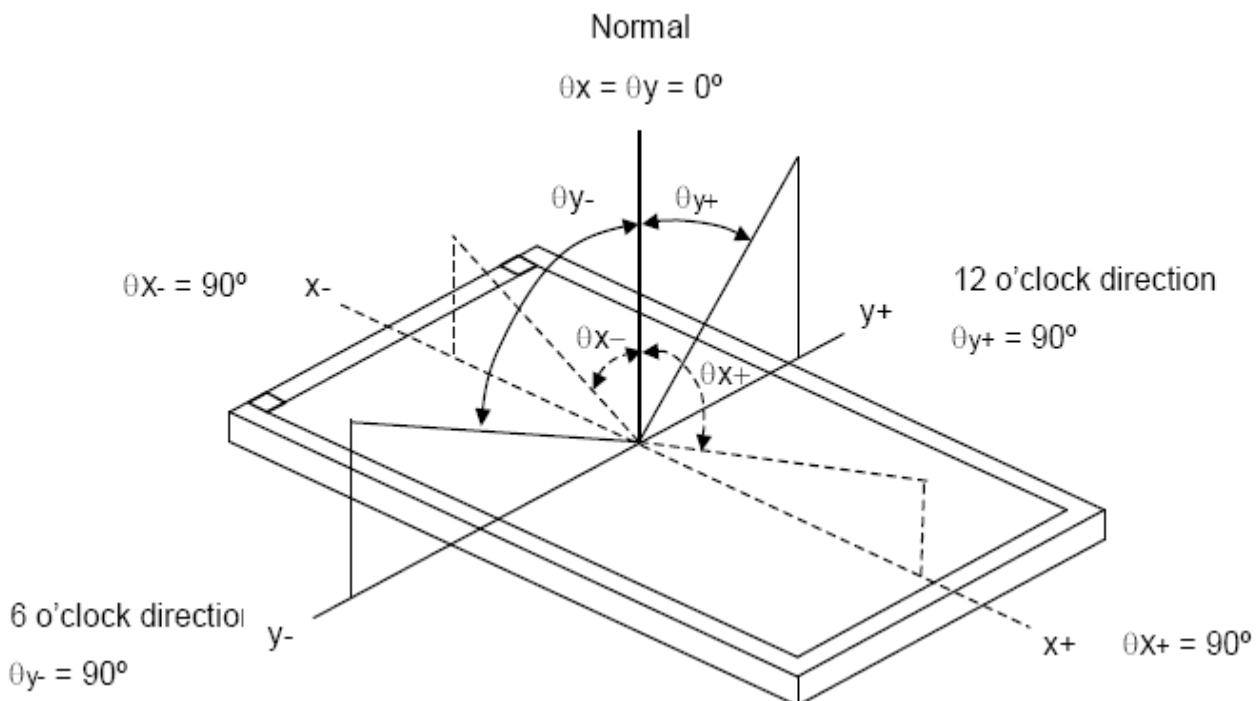

Product Specification	Model:	AWT-320240T35P02	Rev. No.	Issued Date.	Page.
			A	2012/03/05	11 / 21

**Note (2)** Definition of Contrast Ratio(CR) :  
measured at the center point of panel

$$CR = \frac{\text{Luminance with all pixels white}}{\text{Luminance with all pixels black}}$$

**Note (3)** Definition of Response Time : Sum of  $T_R$  and  $T_F$

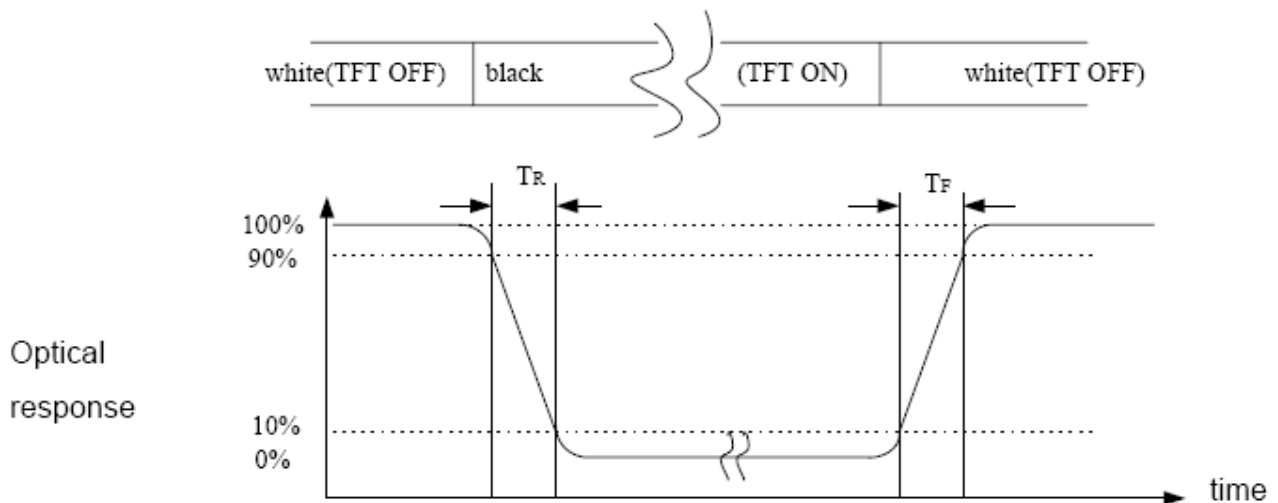

**Note (4)** Definition of optical measurement setup

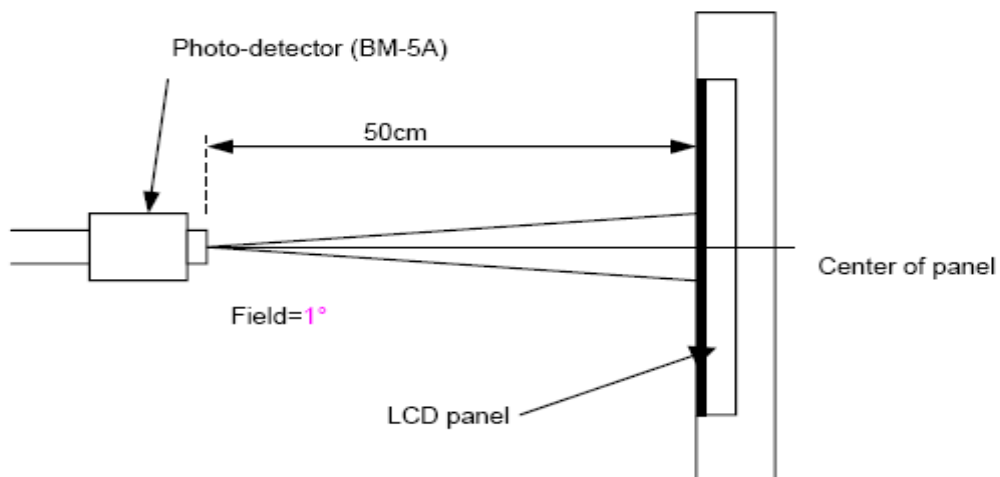

<i>Product Specification</i>	<i>Model:</i>	<i>AWT-320240T35P02</i>	<i>Rev. No.</i>	<i>Issued Date.</i>	<i>Page.</i>
			A	2012/03/05	12 / 21

## 10. Reliability

### 10. 1. MTBF

The LCD module shall be designed to meet a minimum MTBF value of 50000 hours with normal. (25°C in the room without sunlight)

### 10. 2. Test condition

NO.	ITEM	CONDITION	CRITERION
1	High Temperature Non-Operating Test	80°C * 240Hrs	<ul style="list-style-type: none"> <li>◦ No Defect Of Operational Function In Room Temperature Are Allowable.</li> <li>◦ IDD of LCM in Pre-and Post-Test Should Follow Specification</li> </ul>
2	Low Temperature Non-Operating Test	-30°C * 240Hrs	
3	High Temperature/Humidity Non-Operating Test	50°C * 90%RH * 240 Hrs	
4	High Temperature Operating Test	70°C * 240Hrs	
5	Low Temperature Operating Test	-20°C * 240Hrs	
6	Thermal Shock Test	-30°C(30Min) ↔ 80(30Min)* 10 Cycles	

**Notes:**

1. Judgments should be made after exposure in room temperature for two hours.
2. The distill water is used for the high temperature / humidity test.
3. The sample above is individually for every reliability tests condition.

Product Specification	Model:	AWT-320240T35P02	Rev. No.	Issued Date.	Page.
			A	2012/03/05	13 / 21

# 11. Inspection Standards

1. AQL(Acceptable Quality Level)  
AQL of major and minor defect

	MAJOR DEFECT	MINOR DEFECT	MAJOR+MINOR
APPEARANCE	0.40%	1.0%	1.0%
ELECTRIC-OPTICAL	0.15%	0.15%	0.15%

## 2. Basic conditions for inspection

The LCM face to us, in normal environment, the lux is 1000±200.(Darkroom's lux:100±50),

About an angle of incidence 30, a distance of 30cm with normal eye,with an angle of 45 degree to check the products without uncovering the film!

(As shown below)

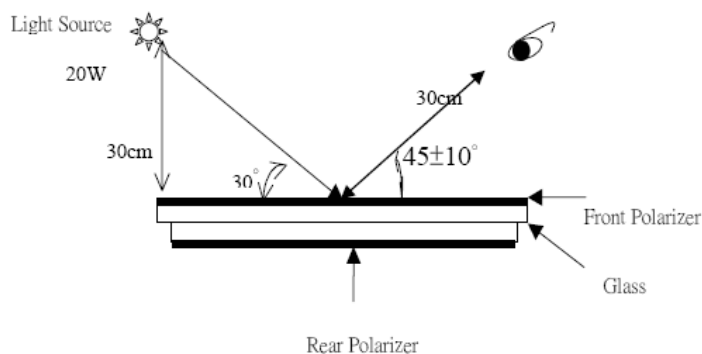

## 3. Inspection item and criteria

### 3.1 Visual inspection criterion in immobility

#### 3.1.1 Glass defect

No	Defect item	Criteria	Remark
1	Dimension Unconformity  (Major defect)	By Engineering Drawing	

Product Specification	Model:	AWT-320240T35P02	Rev. No.	Issued Date.	Page.
			A	2012/03/05	14 / 21

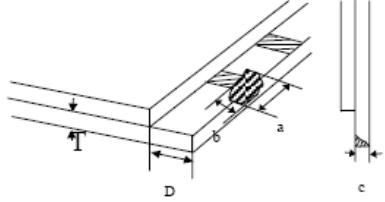
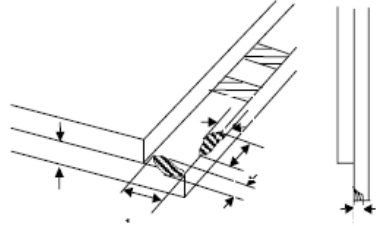
No	Defect item	Criteria	Remark
2	Cracks  (Major defect)	1.Linear cracks on panel <b>【Reject】</b> 2. Nonlinear crack contrast by limited sample	
3	Glass extrude the conductive area  (minor defect)	a: disregards and no influence assemblage 1) $b \leq 1/3$ Pin width (non bonding area) <b>【Accept】</b> 2) bonding area $\leq 0.5$ mm <b>【Accept】</b>	a:Length, b:Width
4	Pin-side · conductive area damaged  (minor defect)	(a c : disregards) $b \leq 1/3$ of effective length for bonding electrode  <b>【Accept】</b>	a : Length · b : Width · c : Thickness 
5	Pin-side · non-conductive area damaged  (minor defect)	1) Damage area don't touch the ITO (Including contraposition mark, except scribing mark ) <b>【Accept】</b> 2) $c < T$ $b \leq BM$ 1/3 of width <b>【Accept】</b> 3) $c = T$ b not touch the seal glue <b>【Accept】</b> 4) a disregards	a : Length · b : Width · c : Thickness 

Product Specification	Model:	AWT-320240T35P02	Rev. No.	Issued Date.	Page.
			A	2012/03/05	15 / 21

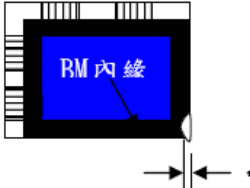
No	Defect item	Criteria	Remark
6	Non-pin-side damage  (minor defect)	c<T  1) b exceeds 1/3 BM  <b>【Reject】</b>	c : Thickness    b: width of damage  
		c=T b not touch the seal glue  <b>【Reject】</b>	

### 3.1.2 LCD appearance defect (View area)

No	Defect item	Criteria	Remark
1	Fiber 、 glass cratch 、 polarizer scratch/folded  (minor defect)	Specification	note1: L : Length , W : Width note2: disregard if out of AA 
		Allowable	
2	Polarizer bubble 、 concave and convex  (minor defect)	$0.05\text{mm} < W \leq 0.1\text{mm};$ $L \leq 3.0\text{mm}$	1
		$W > 0.1\text{mm}; L > 3.0\text{mm}$	0
		$\psi \leq 0.2\text{mm}$	disregard
		$0.2\text{mm} < \psi \leq 0.3\text{mm}$	2
3	Black dots 、 dirty dots 、 impurities 、 eyewinker  (Major defect)	$0.3\text{mm} < \psi \leq 0.5\text{mm}$	1
		$0.5\text{mm} < \psi$	0
		$\psi \leq 0.15\text{mm}$	disregard
		$0.15\text{mm} < \psi \leq 0.25\text{mm}$	2
4	Polarizer prick  (Major defect)	$0.25\text{mm} < \psi \leq 0.3\text{mm}$	1
		$0.3\text{mm} < \psi$	0
		$\psi \leq 0.15\text{mm}$	disregard
4	Polarizer prick  (Major defect)	$\psi \leq 0.1\text{mm}$	disregard
		$0.1\text{mm} < \psi \leq 0.25\text{mm}$	3
		$\psi > 0.25\text{mm}$	0

Product Specification	Model:	AWT-320240T35P02	Rev. No.	Issued Date.	Page.
			A	2012/03/05	16 / 21

### 3.1.3 .FPC

No	Defect item	Criteria		Remark
1	Copper screen peel (Major defect)	Copper screen peel	<b>【 Reject】</b>	
2	No release tape or peel (Major defect)	No release tape or peel	<b>【 Reject】</b>	
3	Dirty dot and impurity of FPC for customer using side (minor defect)	Specification	Allowable	note1: Cannot have stride ITO impurities
		$\psi \leq 0.25\text{mm}$	2	
		$\psi > 0.25$	0	

### 3.1.4 Black tape & Mara tape

1	FPC or H/S black tape shift  (minor defect)	1.shift spec: 1)glue to the polarize <b>【 Reject】</b> 2) IC bare <b>【 Reject】</b> 2. left-and-right spec: 1) exceed of FPC edge or H-S edge <b>【 Reject】</b> 2)IC bare <b>【 Reject】</b>	
2	No black tape (Major defect)	No black tape <b>【 Reject】</b>	
3	Tape position mistake (minor defect)	Not by engineering drawing <b>【 Reject】</b>	
4	Mara tape defect (minor defect)	Peel before pulling the protecting film. <b>【 Reject】</b>	

### 3.1.5 Silicon and Tuffy glue

No	Defect item	Criteria	Remark
1	Quantity of silicon (minor defect)	Uncover the ITO and circuit area. <b>【 Reject】</b>	note: compared by engineering drawing.

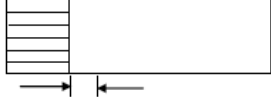

Product Specification	Model:	AWT-320240T35P02	Rev. No.	Issued Date.	Page.
			A	2012/03/05	17 / 21

No	Defect item	Criteria	Remark
2	Tuffy glue (minor defect)	1. Uncover the reveal copper area 【Reject】 2. Cover layer 0.3mm(Min) ~ 3.0mm(Max) 【accept】	note:if customer has special requirement , refer to the technical document. 
3	Depth of glue covering (minor defect)	Depth of glue covering ovetop front Polarizer 【Reject】	Except of the special requirement °

### 3.2 Electrical criteria

No	Defect item	Criteria	Remark
1	No display (Major defect)	No display 【Reject】	
2	Missing line (Major defect)	Missing line 【Reject】	
3	Seg-com light and dark (Major defect)	Seg-com light and dark 【Reject】	ND filter 2% test
4	No display in immobility (Major defect)	No display in immobility 【Reject】	
5	Flicker of Pattern (Major defect)	Flicker of Pattern 【Reject】	
6	Mura (Major defect)	ND filter 2% test	
7	Over current (Major defect)	Over current 【Reject】	
8	Voltage out of specification (Major defect)	Voltage out of specification 【Reject】	
9	Pattern blur ,error code (Major defect)	Pattern blur ,error code 【Reject】	
10	Dark light, Flicker (Major defect)	Dark light, Flicker 【Reject】	

Product Specification	Model:	AWT-320240T35P02	Rev. No.	Issued Date.	Page.
			A	2012/03/05	18 / 21

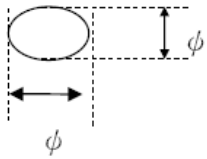
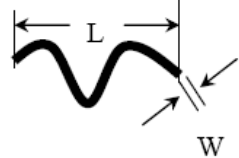
No	Defect item	Criteria	Allowable	Remark
11	Black/White dots · Dirty dots · eyewinker  (Major defect)	Specification	Allowable	Note1: disregard if out of AA  
		$\psi \leq 0.15\text{mm}$	disregard	
		$0.15\text{mm} < \psi \leq 0.25\text{mm}$	2	
		$0.25\text{mm} < \psi \leq 0.3\text{mm}$	1	
		$0.3\text{mm} < \psi$	0	
12	Fiber · glass cratch · polarizer scratch/folded  (minor defect)	$W \leq 0.03\text{mm}$	disregard	note1: L : Length · W : Width note2: disregard if out of AA  
		$0.03\text{mm} < W \leq 0.05\text{mm}$ ; $L \leq 3.0\text{mm}$	2	
		$0.05\text{mm} < W \leq 0.1\text{mm}$ ; $L \leq 3.0\text{mm}$	1	
		$W > 0.1\text{mm}$ ; $L > 3.0\text{mm}$	0	

<i>Product Specification</i>	<i>Model:</i>	AWT-320240T35P02	<i>Rev. No.</i>	<i>Issued Date.</i>	<i>Page.</i>
			A	2012/03/05	19 / 21

## 12. Precautions For Using LCD Modules

Please pay attentions to the followings as using the LCD module.

### 12.1 Handling

- (a) Do not apply strong mechanical stress like drop, shock or any force to LCD module. It may cause improper operation, even damage.
- (b) Because the ITO film very fragile and easy to be damaged, do not hit, press or rub the display surface with hard materials.
- (c) Do not put heavy or hard material on the display surface, and do not stack LCD modules.
- (d) If the display surface is dirty, please wipe the surface softly with cotton swab or clean cloth.
- (e) Wipe off water droplets or oil immediately.
- (f) Protect the LCD module from ESD. It will damage the LSI and the electronic circuit.
- (g) Do not touch the output pins directly with bare hands.
- (h) Do not disassemble the LCD module.

### 12.2 Storage

- (a) Do not leave the LCD modules in high temperature, especially in high humidity for a long time.
- (b) Do not expose the LCD modules to sunlight directly.
- (c) The liquid crystal is deteriorated by ultraviolet. Do not leave it in strong ultraviolet ray for a long time.
- (d) Avoid condensation of water. It may cause improper operation.
- (e) Please stack only up to the number stated on carton box for storage and transportation. Excessive weight will cause deformation and damage of carton box.

### 12.3 Operation

- (a) When mounting or dismounting the LCD modules, turn the power off.
- (b) Protect the LCD modules from electric shock.
- (c) The Driver IC control algorithms stated above should always obeyed to avoid damaging the LSI and electronic circuit.
- (d) Be careful to avoid mixing up the polarity of power supply for backlight.

<i>Product Specification</i>	<i>Model:</i>	<i>AWT-320240T35P02</i>	<i>Rev. No.</i>	<i>Issued Date.</i>	<i>Page.</i>
			A	2012/03/05	20 / 21

- (e) Absolute maximum rating specified above has to be always kept in any case. Exceeding it may cause non-recoverable damage of electronic components or, nevertheless, burning.
- (f) When a static image is displayed for a long time, remnant image is likely to occur.
- (g) Be sure to avoid bending the FPC to an acute shape, it might break FPC.

#### **12.4 Others**

- (a) If the liquid crystal leaks from the panel, it should be kept away from the eyes or mouth.
- (b) It is recommended to peel off the protection film on the ITO film slowly so that the electrostatic charge can be minimized.
- (c) It is recommended to peel off the protection film on the polarizer slowly so that the electrostatic charge can be minimized.

<i>Product Specification</i>	<i>Model:</i>	AWT-320240T35P02	<i>Rev. No.</i>	<i>Issued Date.</i>	<i>Page.</i>
			A	2012/03/05	21 / 21

### 13. Records Of Version

<b>Version</b>	<b>Revise Date</b>	<b>Page</b>	<b>Content</b>
A	2012-03-05	All	FIRST ISSUE



Компания «ЭлектроПласт» предлагает заключение долгосрочных отношений при поставках импортных электронных компонентов на взаимовыгодных условиях!

Наши преимущества:

- Оперативные поставки широкого спектра электронных компонентов отечественного и импортного производства напрямую от производителей и с крупнейших мировых складов;
- Поставка более 17-ти миллионов наименований электронных компонентов;
- Поставка сложных, дефицитных, либо снятых с производства позиций;
- Оперативные сроки поставки под заказ (от 5 рабочих дней);
- Экспресс доставка в любую точку России;
- Техническая поддержка проекта, помощь в подборе аналогов, поставка прототипов;
- Система менеджмента качества сертифицирована по Международному стандарту ISO 9001;
- Лицензия ФСБ на осуществление работ с использованием сведений, составляющих государственную тайну;
- Поставка специализированных компонентов (Xilinx, Altera, Analog Devices, Intersil, Interpoint, Microsemi, Aeroflex, Peregrine, Syfer, Eurofarad, Texas Instrument, Miteq, Cobham, E2V, MA-COM, Hittite, Mini-Circuits, General Dynamics и др.);

Помимо этого, одним из направлений компании «ЭлектроПласт» является направление «Источники питания». Мы предлагаем Вам помощь Конструкторского отдела:

- Подбор оптимального решения, техническое обоснование при выборе компонента;
- Подбор аналогов;
- Консультации по применению компонента;
- Поставка образцов и прототипов;
- Техническая поддержка проекта;
- Защита от снятия компонента с производства.



#### Как с нами связаться

**Телефон:** 8 (812) 309 58 32 (многоканальный)

**Факс:** 8 (812) 320-02-42

**Электронная почта:** [org@eplast1.ru](mailto:org@eplast1.ru)

**Адрес:** 198099, г. Санкт-Петербург, ул. Калинина, дом 2, корпус 4, литера А.