



# har-bus® HM male connector



## General information

|                                |  |                        |
|--------------------------------|--|------------------------|
| Design                         | IEC 61076-4-101  |                        |
| No. of contacts                | 55 - 220 signal (77 - 308 fully shielded); or customized |                        |
| Contact spacing                | 2,0mm  |                        |
| Test voltage                   | 750V AC  |                        |
| Contact resistance             | max. 20mOhm  |                        |
| Insulation resistance          | min. 10 <sup>10</sup> Ohm                                |                        |
| Working current                | 1A at 70°C   | (see derating diagram) |
| Temperature range              | -55°C ... +125°C   |                        |
| Termination technology         | press-in   |                        |
| Clearance & creepage distance  | 0,8 mm each for fixed connector                          |                        |
| Insertion and withdrawal force | insertion force per contact:                             | 0,75N max.             |
|                                | withdrawal force per contact:                            | 0,15N min.             |
| Mating cycles                  | acc. to performance level, see table below               |                        |
| UL file                        | E102079  |                        |
| RoHS - compliant               | Yes  |                        |
| Leadfree                       | Yes  |                        |

## Insulator material

|                                    |   |
|------------------------------------|---|
| Material                           | PC (Polycarbonate, glass fiber reinforcement 20%) |
| Colour                             | RAL 7032 (grey)                                   |
| UL classification                  | UL 94-V0  |
| Material group acc. to IEC 60664-1 | IIIa (175 ≤ CTI < 400)                            |
| NFF classification                 | I2, F1  |

## Contact material

|                        |  |
|------------------------|--|
| Contact material       | Copper alloy                               |
| Treatment contact zone | Bellcore recommended lubricant (PPE)       |
| Plating press-in zone  | Ni   |
| Plating contact zone   | acc. to performance level, see table below |

| performance level | mating cycles           |                                       | plating contact zone                              |
|-------------------|-------------------------|---------------------------------------|---|
|                   | acc. to IEC 61076-4-101 | complementary acc. to IEC 61076-4-101 |   |
| 1                 | 500                     |                                       | <i>Au over PdNi over Ni</i>                       |
| 2                 | 250                     |                                       | <i>Au over PdNi over Ni</i>                       |
| NM30 (S4)         |                         | 500                                   | min. 0,76µm (30pinch) noble metal (alloy) over Ni |
| Au30              |                         | 500                                   | min. 0,76µm (30pinch) Au over Ni                  |
| Au50              |                         | 500                                   | min. 1,27µm (50pinch) Au over Ni                  |

Standard plating options highlighted in *italic*, other plating options are available on request.

## Recommended configuration of plated through holes for press-in termination

In addition to the hot-air-level (HAL), other PCB surfaces are getting more important. Due to their different properties - such as mechanical strength and coefficient of friction - we recommend the following configuration of PCB through holes.

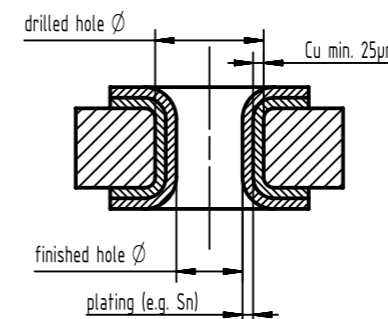

|   |                |               |
|---|----------------|---------------|
| Tin plated PCB (HAL) acc. to EN 60352-5 | Drilled hole Ø | 0,7±0,02mm    |
|   | Sn             | max. 15µm     |
|   | plated hole Ø  | 0,60 - 0,65mm |
| Chemical tin plated PCB                 | Drilled hole Ø | 0,7±0,02mm    |
|   | Sn             | min. 0,8µm    |
|   | plated hole Ø  | 0,60 - 0,65mm |
| Gold /Nickel plated PCB                 | Drilled hole Ø | 0,7±0,02mm    |
|   | Ni             | 3 - 7µm       |
|   | Au             | 0,05 - 0,12µm |
| plated hole Ø                           | 0,60 - 0,65mm  |               |
| Silver plated PCB                       | Drilled hole Ø | 0,7±0,02mm    |
|   | Ag             | 0,1 - 0,3µm   |
|   | plated hole Ø  | 0,60 - 0,65mm |
| Copper plated PCB (OSP)                 | Drilled hole Ø | 0,7±0,02mm    |
|   | plated hole Ø  | 0,60 - 0,65mm |

## Assembly instructions

It is highly recommended to use HARTING press-in tools to ensure a reliable press-in process. Please refer to the catalogue for tools, machines and further information about the press-in process.

## Circuit density

When using the specified diameter of the finished through hole according to IEC 61 076-4-101 (0.6 ± 0.05mm) with an appropriate annular ring, the remaining distance between the rings is about 1mm.

Under the condition that the width of the track and the space between should be equal, two tracks of 0.2mm width or three tracks of 0.14mm width can be placed between two rings.

Typical designs are shown in the drawing on the right side.



## Derating diagram acc. to IEC 60512-5 (Current carrying capacity)

The current carrying capacity is limited by maximum temperature of materials for inserts and contacts including terminals. The current capacity curve is valid for continuous, non interrupted current loaded contacts of connectors when simultaneous power on all contacts is given, without exceeding the maximum temperature.

Control and test procedures according to DIN IEC 60512-5

Curve 1 shows raise in temperature  
Curve 2 shows nominal derating Date Name  
Curve 3 shows reduced values as per IEC512

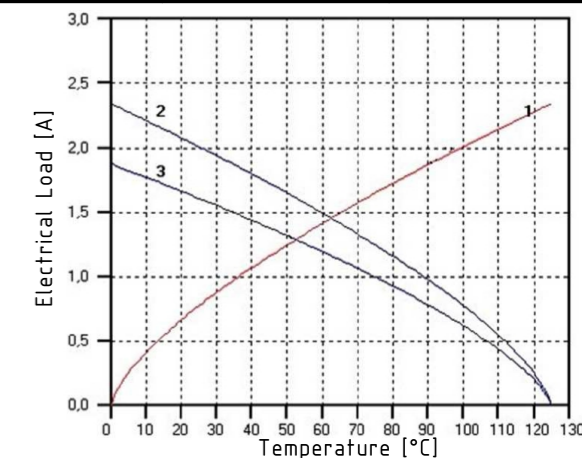

|                          |                       |                            |              |                 |                                     |               |
|--------------------------|-----------------------|----------------------------|--------------|-----------------|-------------------------------------|---------------|
|                          | All rights reserved   | Created by                 | Inspected by | Standardisation | Date                                | State         |
|                          | Department EC PD - DE | STORCK                     | LEHNERT      | HOFFMANN        | 2018-04-23                          | Final Release |
| HARTING Electronics GmbH |                       | Title                      |              |                 | Doc-Key / ECM-Nr.                   |               |
| D-32339 Espelkamp        |                       | har-bus® HM male connector |              |                 | 100580919/UGD/000/B<br>500000134078 |               |
|                          |                       | Type                       | Number       | Rev.            |                                     | Page          |
|                          |                       | DS                         | 17001100101  | B               |                                     | 1/1           |

# Mouser Electronics

Authorized Distributor

Click to View Pricing, Inventory, Delivery & Lifecycle Information:

## HARTING:

[17011101201](#) [17011102201](#) [17102002201](#) [17111761201](#) [17111762201](#) [17112202001](#) [17112202201](#)  
[17122001201](#) [17122002201](#) [17122501001](#) [17122502001](#) [17130951201](#) [17130952201](#) [17131271201](#) [17131271202](#)  
[17141102201](#) [17122502201](#) [17151692003](#) [17102001201](#) [17102441001](#) [17102441201](#) [17102442201](#)  
[17131272202](#) [17141461202](#) [17141462601](#) [17151691201](#) [17151692201](#) [17151252201](#) [17131272201](#) [17141461201](#)  
[17141462201](#) [17141462202](#) [17102442001](#) [17131272601](#)



Компания «ЭлектроПласт» предлагает заключение долгосрочных отношений при поставках импортных электронных компонентов на взаимовыгодных условиях!

Наши преимущества:

- Оперативные поставки широкого спектра электронных компонентов отечественного и импортного производства напрямую от производителей и с крупнейших мировых складов;
- Поставка более 17-ти миллионов наименований электронных компонентов;
- Поставка сложных, дефицитных, либо снятых с производства позиций;
- Оперативные сроки поставки под заказ (от 5 рабочих дней);
- Экспресс доставка в любую точку России;
- Техническая поддержка проекта, помощь в подборе аналогов, поставка прототипов;
- Система менеджмента качества сертифицирована по Международному стандарту ISO 9001;
- Лицензия ФСБ на осуществление работ с использованием сведений, составляющих государственную тайну;
- Поставка специализированных компонентов (Xilinx, Altera, Analog Devices, Intersil, Interpoint, Microsemi, Aeroflex, Peregrine, Syfer, Eurofarad, Texas Instrument, Miteq, Cobham, E2V, MA-COM, Hittite, Mini-Circuits, General Dynamics и др.);

Помимо этого, одним из направлений компании «ЭлектроПласт» является направление «Источники питания». Мы предлагаем Вам помощь Конструкторского отдела:

- Подбор оптимального решения, техническое обоснование при выборе компонента;
- Подбор аналогов;
- Консультации по применению компонента;
- Поставка образцов и прототипов;
- Техническая поддержка проекта;
- Защита от снятия компонента с производства.



#### Как с нами связаться

**Телефон:** 8 (812) 309 58 32 (многоканальный)

**Факс:** 8 (812) 320-02-42

**Электронная почта:** [org@eplast1.ru](mailto:org@eplast1.ru)

**Адрес:** 198099, г. Санкт-Петербург, ул. Калинина, дом 2, корпус 4, литера А.