



## Multi-Output Power-Supply Controller

### DESCRIPTION

The Si9136 is a current-mode PWM and PSM converter controller, with two synchronous buck converters (3.3 V and 5 V) and a flyback (non-isolated buck-boost) converter (12 V). Designed for portable devices, it offers a total five power outputs (three tightly regulated dc/dc converter outputs, a precision 3.3 V reference and a 5 V LDO output). It requires minimum external components and is capable of achieving conversion efficiencies approaching 95 %.

The Si9136 is available in a 28-pin SSOP package and specified to operate over the extended commercial (0 °C to 90 °C) temperature range.

### FEATURES

- Up to 95 % Efficiency
- 3 % Total Regulation (Each Controller)
- 5.5 V to 30 V Input Voltage Range
- 3.3 V, 5 V, and 12 V Outputs
- 200 kHz Low-Noise Fixed Frequency Operation
- Precision 3.3 V Reference Output
- 30 mA Linear Regulator Output
- High Efficiency Pulse Skipping Mode Operation at Light Load
- Only Three Inductors Required - No Transformer
- LITTLE FOOT® Optimized Output Drivers
- Internal Soft-Start
- Minimal External Control Components
- 28-Pin SSOP Package

### FUNCTIONAL BLOCK DIAGRAM

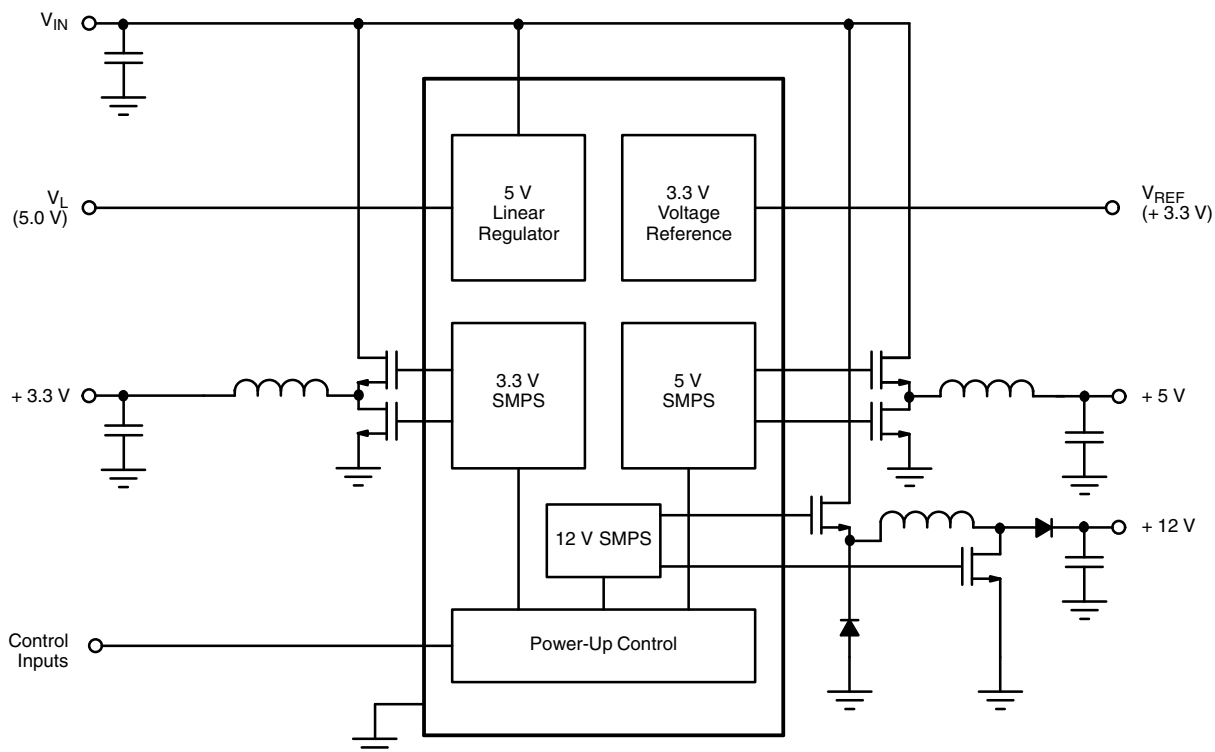

ABSOLUTE MAXIMUM RATINGS			
Parameter	Limit	Unit	
$V_{IN}$ to GND	- 0.3 to + 36 V	V	
$P_{GND}$ to GND	$\pm 2$		
$V_L$ to GND	- 0.3 to + 6.5 V		
BST <sub>3</sub> , BST <sub>5</sub> , BSTFY to GND	- 0.3 V to + 36 V		
$V_L$ Short to GND	Continuous		
LX <sub>3</sub> to BST <sub>3</sub> ; LX <sub>5</sub> to BST <sub>5</sub> ; LXFY to BST	- 6.5 V to 0.3 V	V	
Inputs/Outputs to GND (CS <sub>3</sub> , CS <sub>5</sub> , CSP, CSN)	- 0.3 V to ( $V_L + 0.3$ V)		
5 ON/OFF, 3 ON/OFF, 12 ON/OFF	- 0.3 V to + 5.5 V		
DL3, DL5 to PGND	- 0.3 V to ( $V_L + 0.3$ V)		
DLFY to PGND	Input of Flyback		
DH3 to LX <sub>3</sub> , DH5 to LX <sub>5</sub> , DHFY to LXFY	- 0.3 V to (BSTX + 0.3 V)	V	
Continuous Power Dissipation ( $T_A = 90$ °C) <sup>a</sup>	28-Pin SSOP <sup>b</sup>	572	mW
Operating Temperature Range		0 °C to 90 °C	°C
Storage Temperature Range		- 40 °C to 125 °C	
Lead Temperature (Soldering, 10 Sec.)		300	

Notes:

a. Device Mounted with all leads soldered or welded to PC board.

b. Derate 9.25 mW/°C above 90 °C.

Stresses beyond those listed under "Absolute Maximum Ratings" may cause permanent damage to the device. These are stress ratings only, and functional operation of the device at these or any other conditions beyond those indicated in the operational sections of the specifications is not implied. Exposure to absolute maximum rating conditions for extended periods may affect device reliability.

SPECIFICATIONS					
Parameter	Specific Test Conditions $V_{IN} = 15$ V, $I_{VL} = I_{REF} = 0$ mA $T_A = 0$ °C to 90 °C, All Converters ON	Limits			Unit
		Min. <sup>a</sup>	Typ. <sup>b</sup>	Max. <sup>a</sup>	
<b>3.3 V Buck Controller</b>					
Total Regulation (Line, Load, and Temperature)	$V_{IN} = 6$ to 30 V, $0 < V_{CS3} - V_{FB3} < 90$ mV	3.23	3.33	3.43	V
Line Regulation	$V_{IN} = 6$ to 30 V			$\pm 0.5$	%
Load Regulation	$0 < V_{CS3} - V_{FB3} < 90$ mV			$\pm 0.5$	
Current Limit	$V_{CS3} - V_{FB3}$	90	125	160	mV
Bandwidth	$L = 10$ $\mu$ H, $C = 330$ $\mu$ F		50		kHz
Phase Margin	$R_{SENSE} = 20$ m $\Omega$		65		°
<b>5 V Buck Controller</b>					
Total Regulation (Line, Load, and Temperature)	$V_{IN} = 6$ to 30 V, $0 < V_{CS5} - V_{FB5} < 90$ mV	4.88	5.03	5.18	V
Line Regulation	$V_{IN} = 6$ to 30 V			$\pm 0.5$	%
Load Regulation	$0 < V_{CS5} - V_{FB5} < 90$ mV			$\pm 0.5$	
Current Limit	$V_{CS5} - V_{FB5}$	90	125	160	mV
Bandwidth	$L = 10$ $\mu$ H, $C = 330$ $\mu$ F		50		kHz
Phase Margin	$R_{SENSE} = 20$ m $\Omega$		65		°
<b>12 V Flyback Controller</b>					
Total Regulation (Line, Load, and Temperature)	$V_{IN} = 6$ to 30 V, $0 < V_{CSP} - V_{CSN} < 300$ mV	11.4	12.0	12.6	V
Line Regulation	$V_{IN} = 6$ to 30 V			$\pm 0.5$	%
Load Regulation	$0 < V_{CSP} - V_{FBN} < 300$ mV			$\pm 0.5$	
Current Limit	$V_{CSP} - V_{CSN}$	330	410	500	mV
Bandwidth	$L = 10$ $\mu$ H, $C = 100$ $\mu$ F		10		kHz
Phase Margin	$R_{SENSE} = 100$ m $\Omega$ , $C_{comp} = 120$ pF		65		°
<b>Internal Regulator</b>					
$V_L$ Output	All Converters OFF, $V_{IN} > 5.5$ , $0 < I_L < 30$ mA	4.7		5.5	V
$V_L$ Fault Lockout Voltage		3.6		4.2	
$V_L$ Fault Lockout Hysteresis			75		mV
$V_L$ /FB5 Switchover Voltage		4.2		4.7	V
$V_L$ /FB5 Switchover Hysteresis			75		mV

<b>SPECIFICATIONS</b>						
Parameter	Specific Test Conditions $V_{IN} = 15\text{ V}$ , $I_{VL} = I_{REF} = 0\text{ mA}$ $T_A = 0\text{ }^\circ\text{C to } 90\text{ }^\circ\text{C}$ , All Converters ON	Limits			Unit	
		Min. <sup>a</sup>	Typ. <sup>b</sup>	Max. <sup>a</sup>		
<b>Reference</b>						
REF Output	No External Load	3.24	3.30	3.36	V	
REF Load Regulation	0 to 1 mA		30	75	mV	
<b>Supply Current</b>						
Supply Current-Shutdown	All Converters OFF, No Load		35	60	$\mu\text{A}$	
Supply Current-Operation	All Converters ON, No Load, $F_{OCS} = 200\text{ kHz}$		1100	1800		
<b>Oscillator</b>						
Oscillator Frequency		180	200	220	kHz	
Maximum Duty Cycle		92	95		%	
<b>Outputs</b>						
Gate Driver Sink/Source Current (Buck)	DL3, DH3, DL5, DH5 Forced to 2 V		1		A	
Gate Driver On-Resistance (Buck)	High or Low		2	7	$\Omega$	
Gate Driver Sink/Source Current (Flyback)	DHFY, DLFY Forced to 2 V		0.2		A	
Gate Driver On-Resistance (Flyback)	High or Low			15	$\Omega$	
<b>5 ON/OFF, 3 ON/OFF, and 12 ON/OFF</b>						
$V_{IL}$				0.8	V	
$V_{IH}$		2.4				

Notes:

a. The algebraic convention whereby the most negative value is a minimum and the most positive a maximum.

b. Typical values are for DESIGN AID ONLY, not guaranteed nor subject to production testing.

## PIN CONFIGURATION

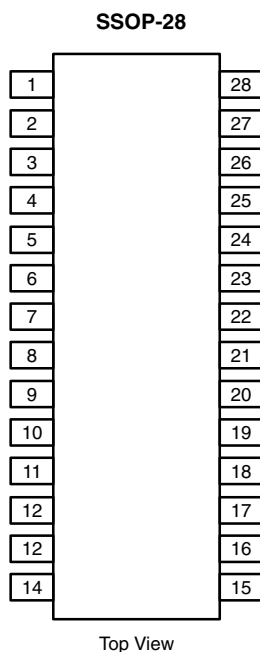

<b>ORDERING DESCRIPTION</b>		
Part Number	Temperature Range	$V_{OUT}$
Si9136LG	0 °C to 90 °C	3.3 V, 5 V, 12 V
Evaluation Board	Temperature Range	Board Type
Si9136DB	0 °C to 90 °C	Surface Mount

PIN DESCRIPTION		
Pin Number	Symbol	Description
1	CS <sub>3</sub>	Current sense input for 3.3 V buck.
2	FBFY	Feedback for flyback.
3	BSTFY	Boost capacitor connection for flyback converter.
4	DH FY	Gate-drive output for flyback high-side MOSFET.
5	LX FY	Inductor connection for flyback converter.
6	DL FY	Gate-drive output for flyback low-side MOSFET.
7	CSP	Current sense positive input for flyback converter.
8	CSN	Current sense negative input for flyback converter.
9	GND	Analog ground.
10	COMP	Flyback compensation connection, if required.
11	REF	3.3 V internal reference.
12	12 ON/ $\overline{\text{OFF}}$	ON and OFF control input for 12 V flyback controller.
13	3.3 ON/ $\overline{\text{OFF}}$	ON and OFF control input for 3.3 V buck controller.
14	5 ON/ $\overline{\text{OFF}}$	ON and OFF control input for 5 V buck controller.
15	CS <sub>5</sub>	Current sense input for 5 V buck controller.
16	DH <sub>5</sub>	Inductor connection for buck 5 V.
17	LX <sub>5</sub>	Gate-drive output for 5 V buck high-side MOSFET.
18	BST <sub>5</sub>	Boost capacitor connection for 5 V buck converter.
19	DL <sub>5</sub>	Gate-drive output for 5 V buck low-side MOSFET.
20	PGND	Power ground.
21	FB <sub>5</sub>	Feedback for 5 V buck.
22	V <sub>L</sub>	5 V logic supply voltage for internal circuitry.
23	V <sub>IN</sub>	Input voltage
24	DL <sub>3</sub>	Gate-drive output for 3.3 V buck low-side MOSFET.
25	BST <sub>3</sub>	Boost capacitor connection for 3.3 V buck converter.
26	LX <sub>3</sub>	Inductor connection for 3.3 V buck low-side MOSFET.
27	DH <sub>3</sub>	Gate-drive output for 3.3 V buck high-side MOSFET.
28	FB <sub>3</sub>	Feedback for 3.3 V buck.

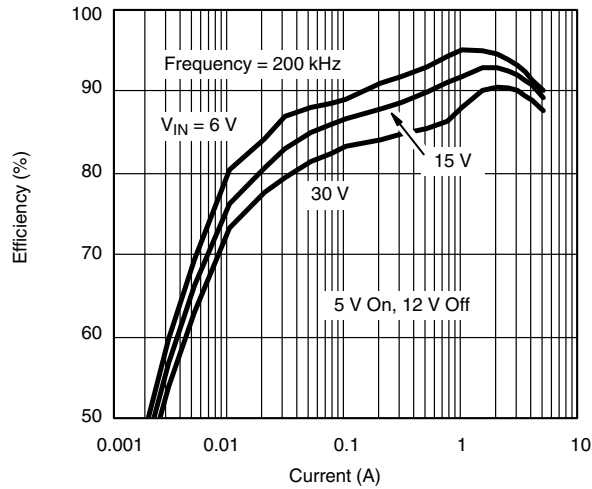
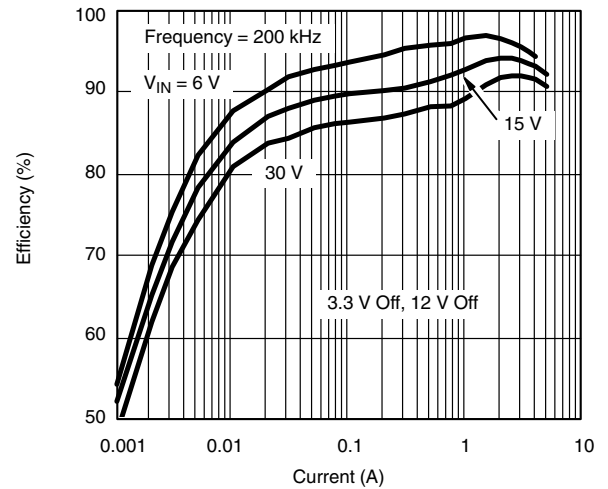
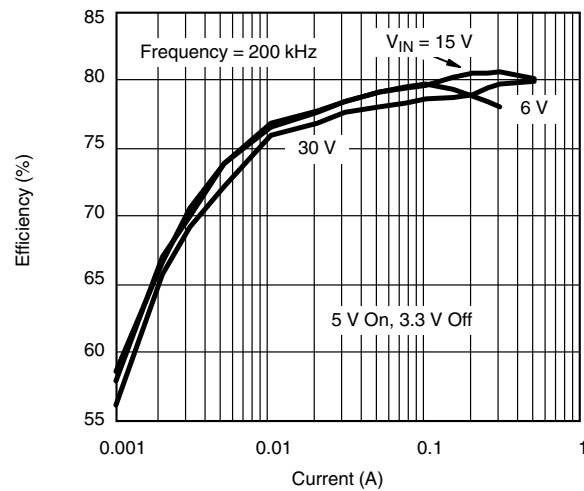
**TYPICAL CHARACTERISTICS** (25 °C, unless otherwise noted)

**Efficiency vs. 3.3 V Output Current**

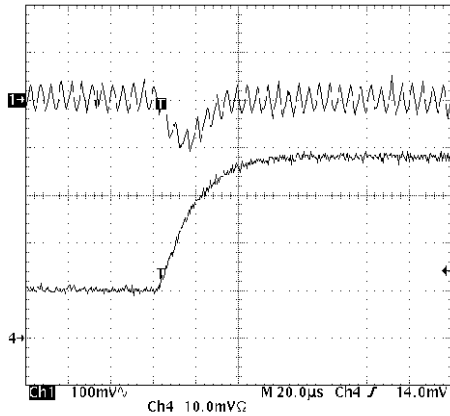
**Efficiency vs. 5.0 V Output Current**

**Efficiency vs. 12 V Output Current**

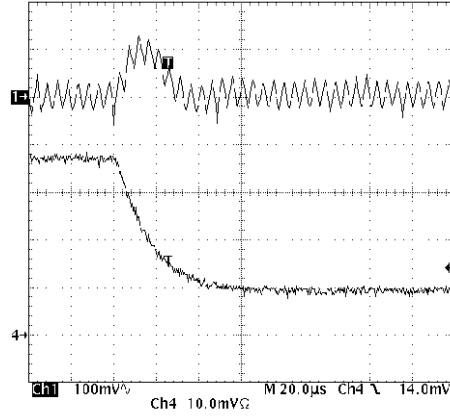
**TYPICAL WAVEFORMS**



PWM Loading  
5 V Converter ( $V_{IN} = 10 V$ )



PWM Unloading  
5 V Converter ( $V_{IN} = 10 V$ )

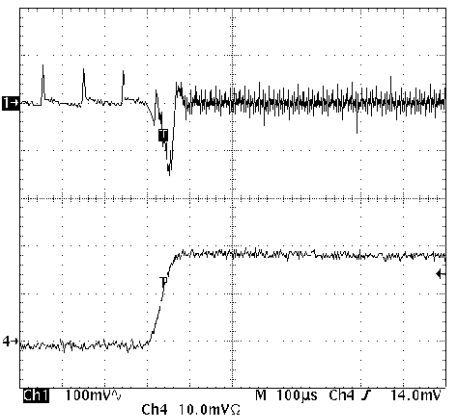

PSM to PWM  
5 V Converter ( $V_{IN} = 10 V$ )

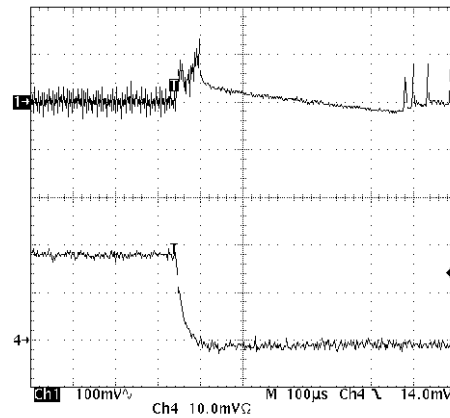

PWM to PSM  
5 V Converter ( $V_{IN} = 10 V$ )

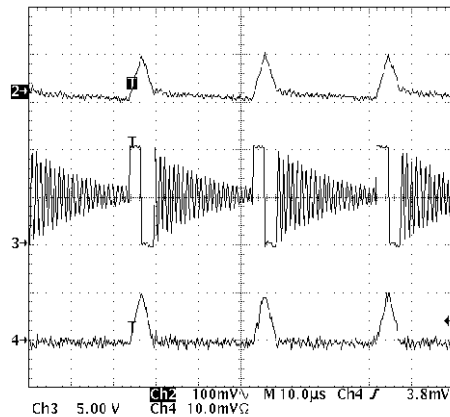

PSM Operation  
5 V Converter ( $V_{IN} = 10 V$ )

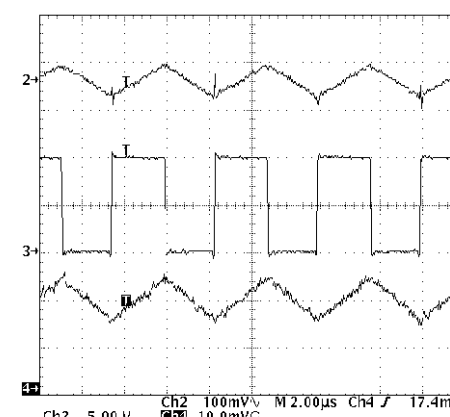

PWM Operation  
5 V Converter ( $V_{IN} = 10 V$ )

**TYPICAL WAVEFORMS**

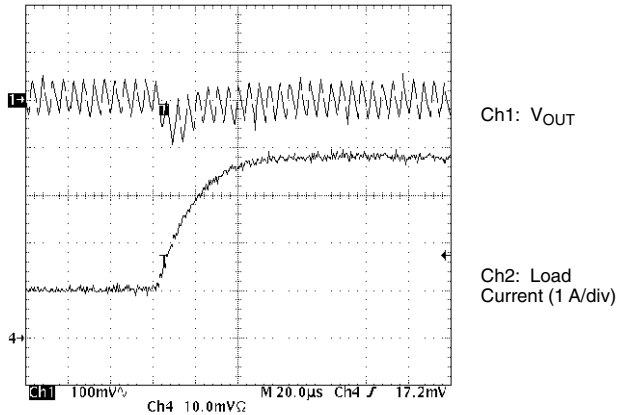

PWM, Loading  
3 V Converter ( $V_{IN} = 10\text{ V}$ )

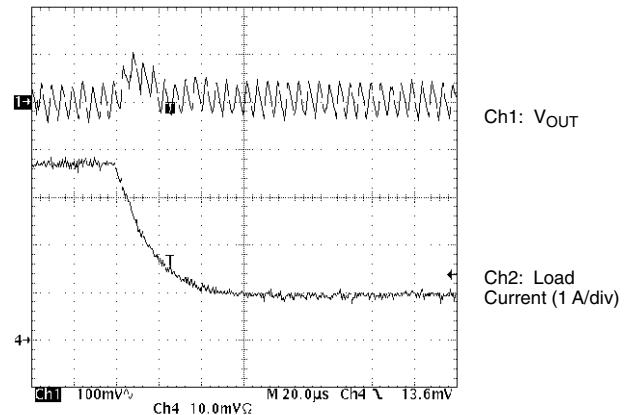

PWM, Unloading  
3 V Converter ( $V_{IN} = 10\text{ V}$ )

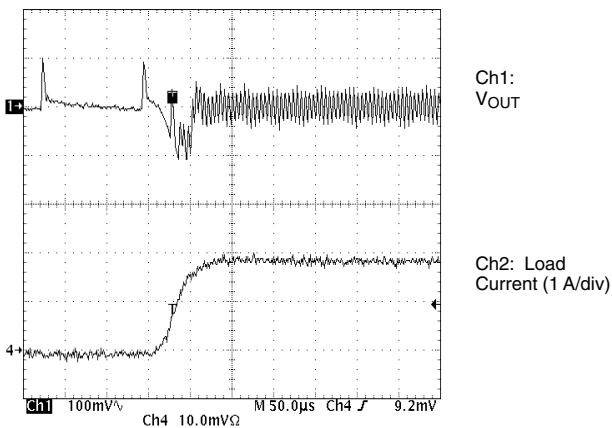

PSM to PWM  
3 V Converter ( $V_{IN} = 10\text{ V}$ )

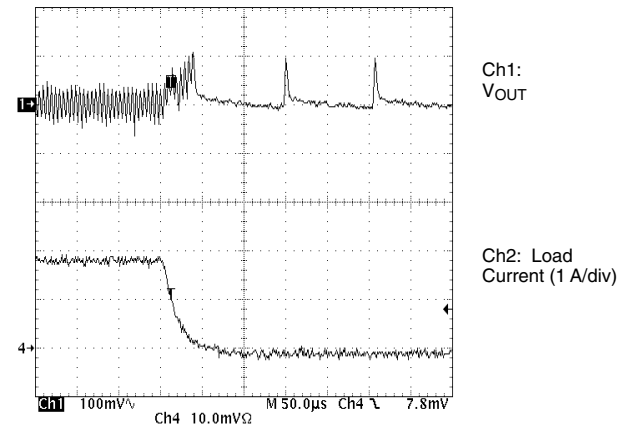

PWM to PSM  
3 V Converter ( $V_{IN} = 10\text{ V}$ )

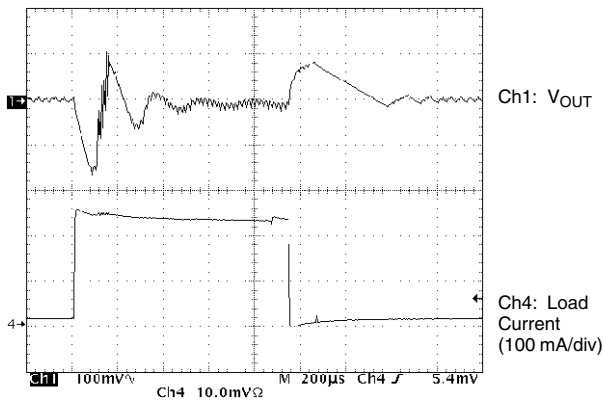

250 mA Transient  
12 V Converter ( $V_{IN} = 10\text{ V}$ )

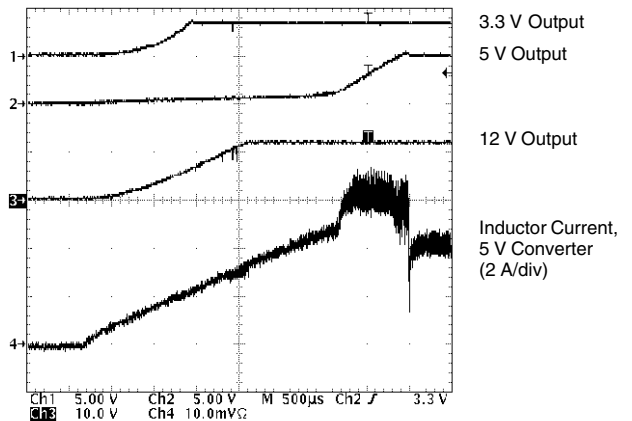

Start-Up

STANDARD APPLICATION CIRCUIT

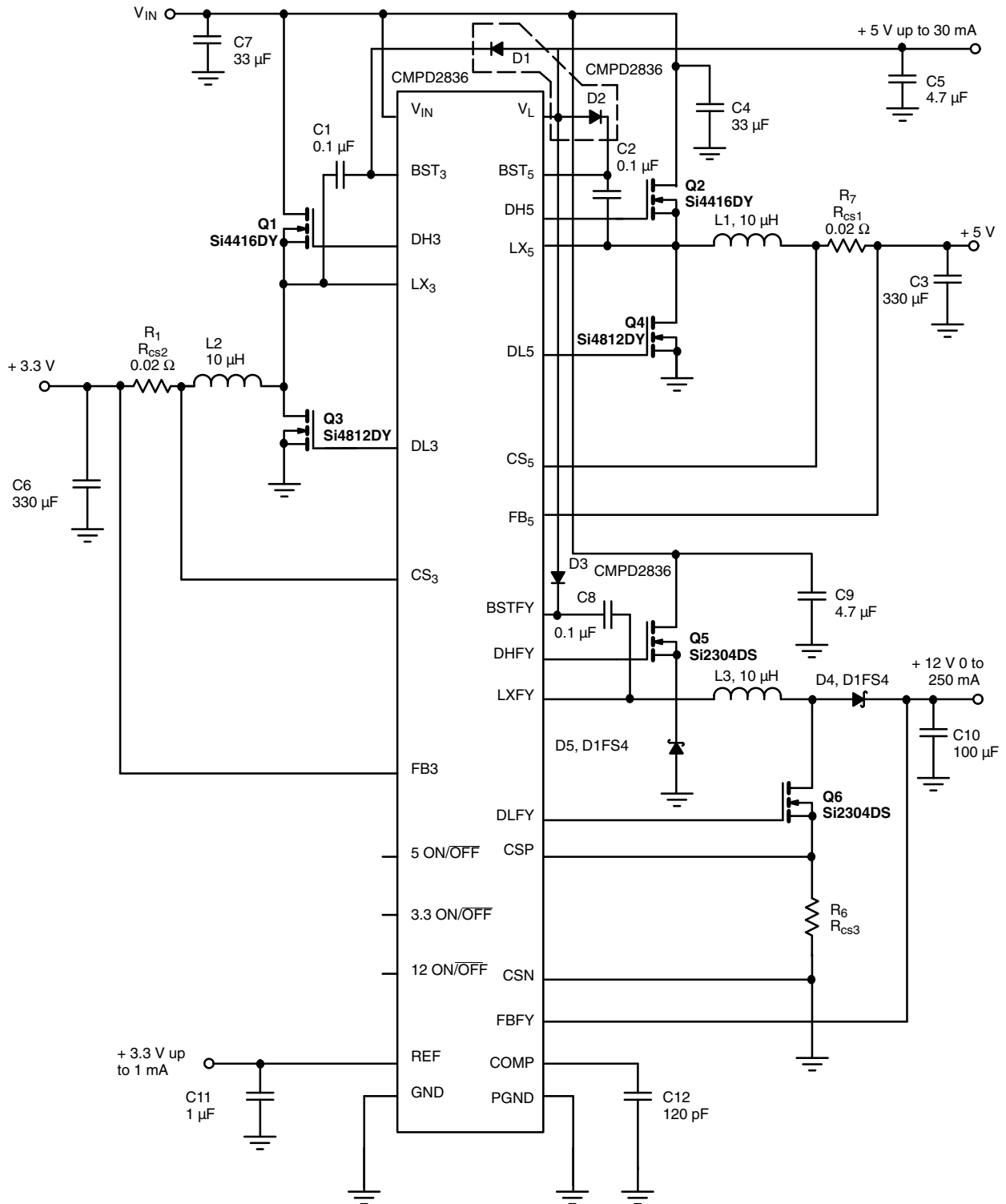
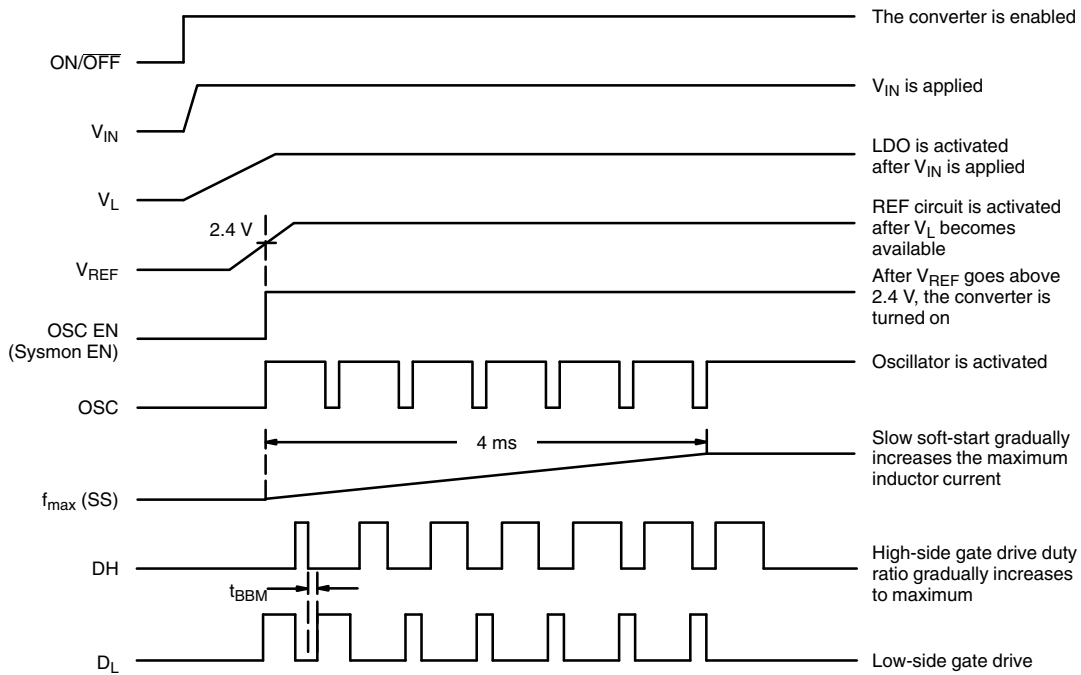
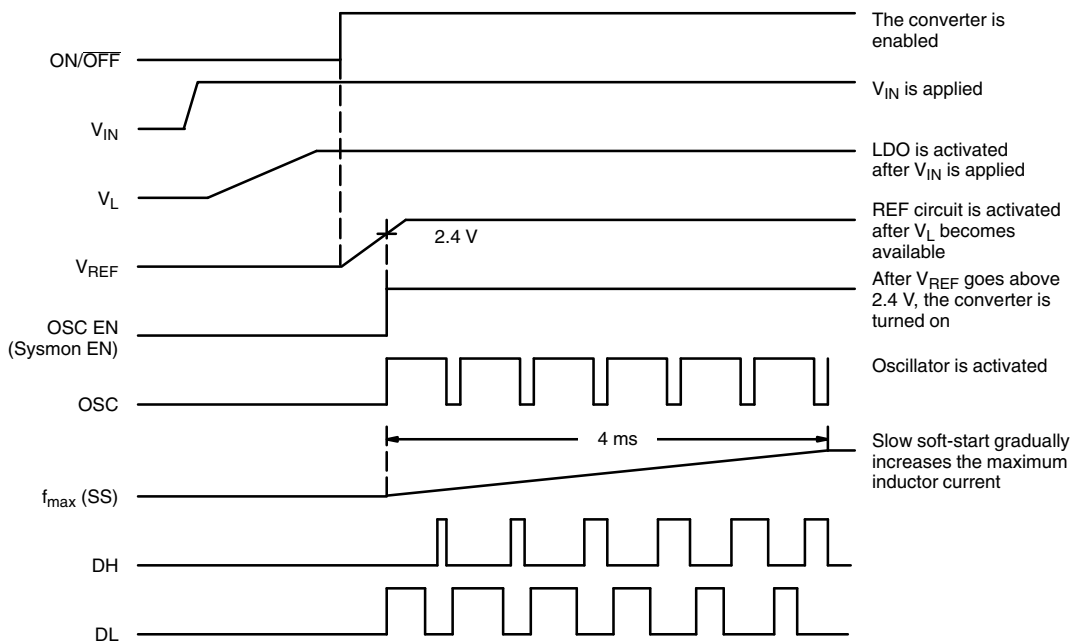

Figure 1.



**TIMING DIAGRAMS**

**Figure 2. Converter is Enabled Before  $V_{IN}$  is Applied**

**Figure 3. Converter is Enabled After  $V_{IN}$  is Applied**

**TIMING DIAGRAMS**

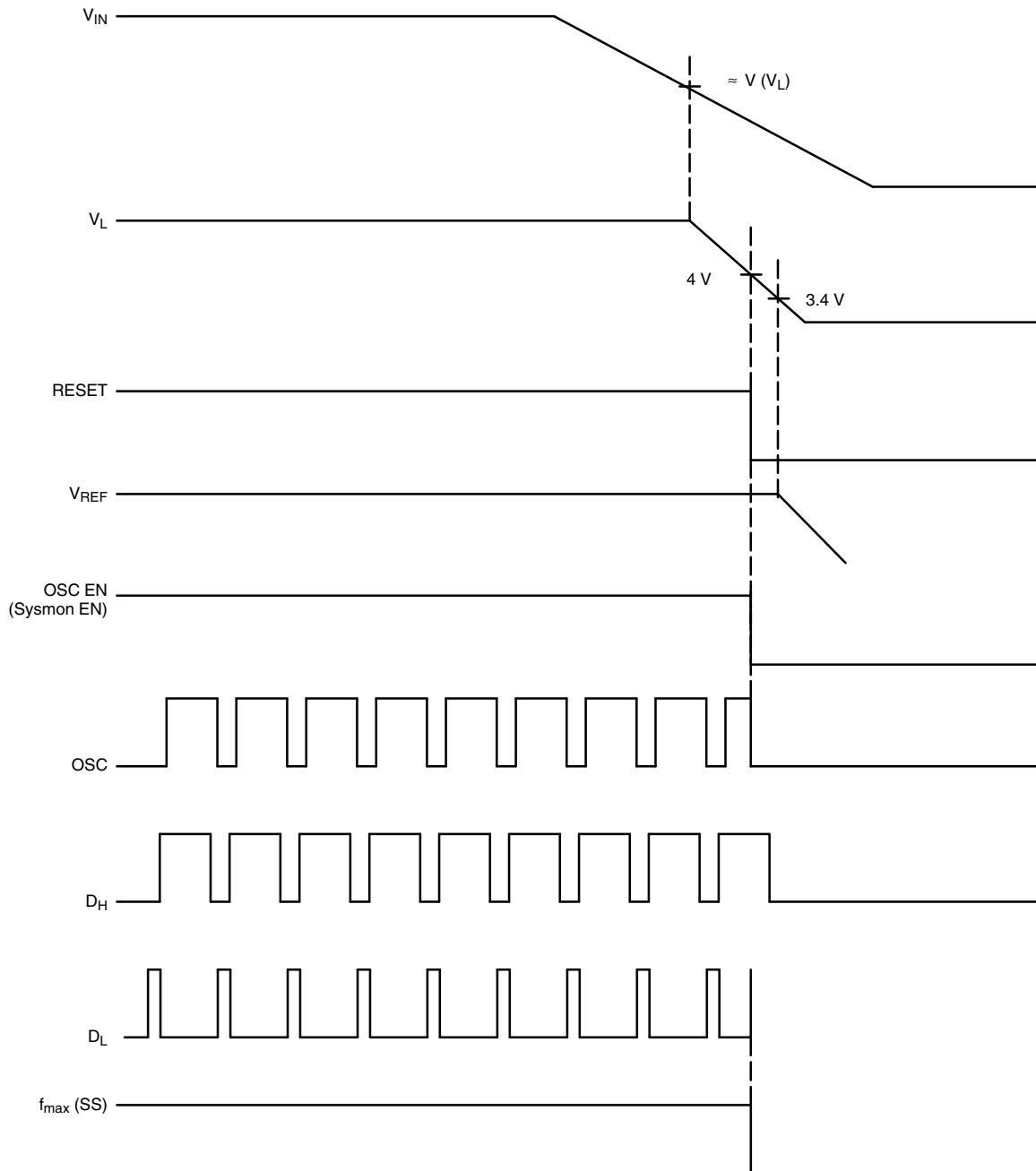
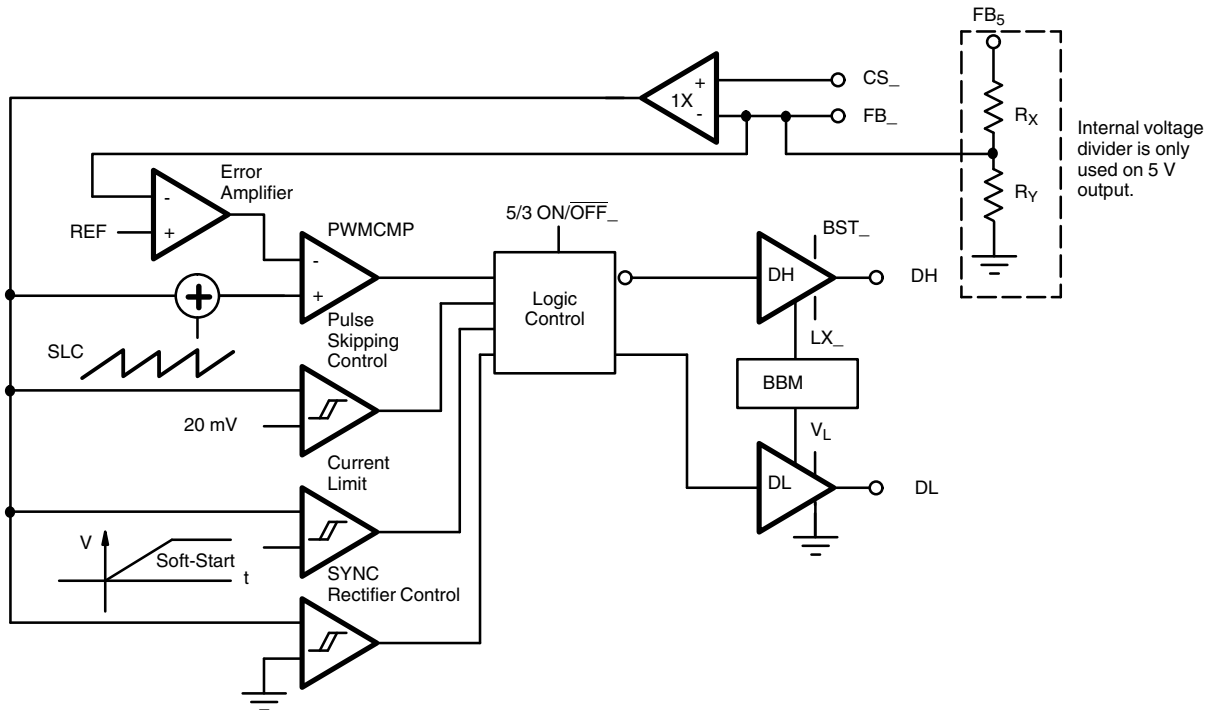
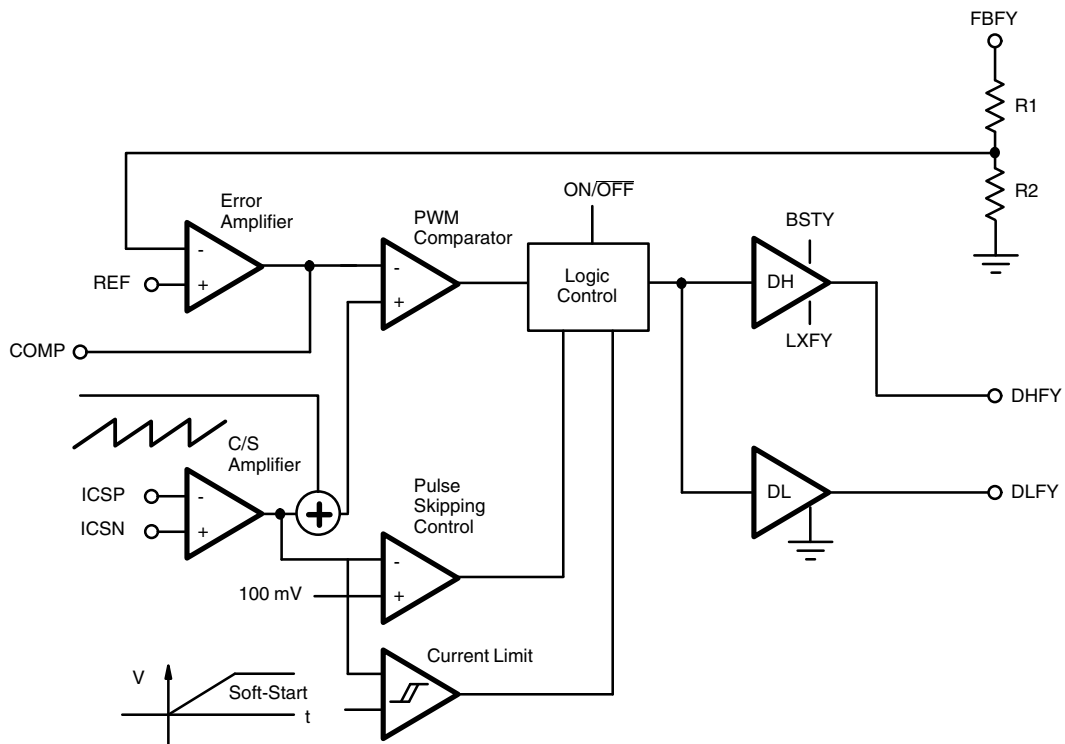

Figure 4. Power Off Sequence

**DETAIL FUNCTIONAL BLOCK DIAGRAM**

**Figure 5. Buck Block Diagram**

**Figure 6. PWM Flyback Block Diagram**

## DETAIL FUNCTIONAL BLOCK DIAGRAM

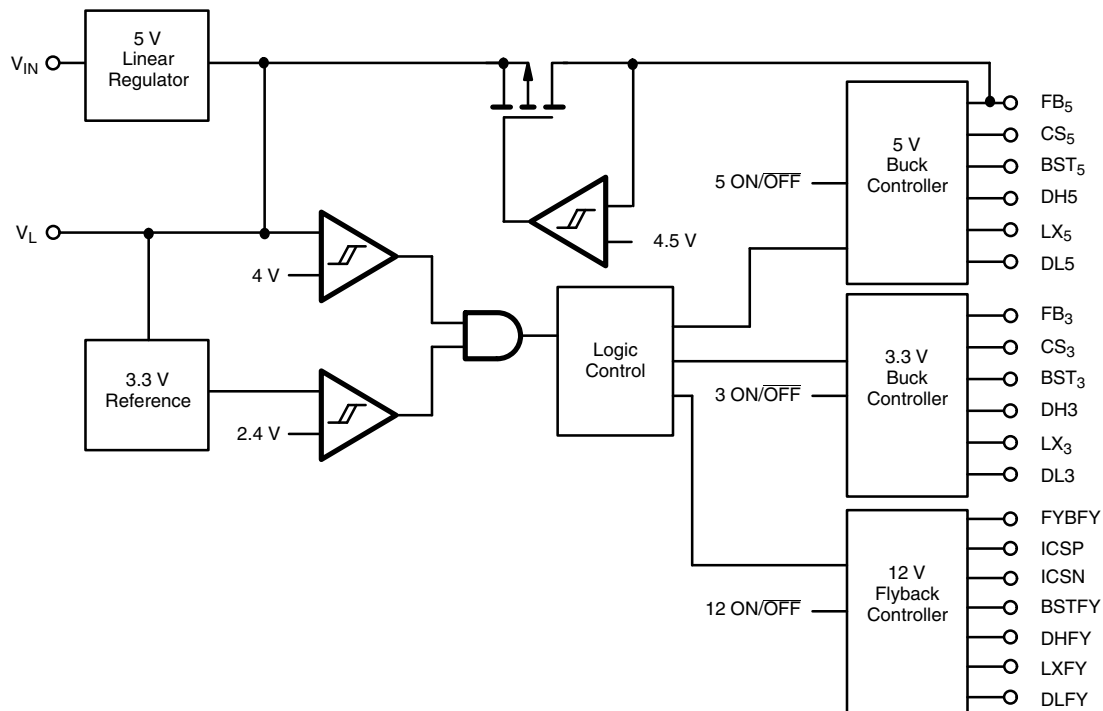

Figure 7. Complete Si9136 Block Diagram

## DESCRIPTION OF OPERATION

### Start-up Sequence

Si9136's outputs are controlled by three specific input control lines; 3.3 ON/OFF, 5 ON/OFF, and 12 ON/OFF. Once  $V_{IN}$  is applied, the  $V_L$ , the 5 V LDO will come up within its tolerance. When any one of these control lines becomes logic high, the precision 3.3 V reference will also come up. Immediately afterwards, the oscillator will begin and the corresponding converter will come up with its own tolerance. In the event of all three converters are turned off, the oscillator and the reference output will be turned off, and the total system will only draw 35  $\mu$ A of supply current.

Each converter can soft-start independently. This internal soft-start circuitry for each converter will gradually increases the inductor maximum peak current during the soft-start period (approximately 4 ms), preventing excessive currents from being drawn from the input.

Si9136 converts a 5.5 V to 30 V input voltage to five different output voltages; two buck (step-down) high current, PWM, switch-mode supplies of 3.3 V and 5 V, one "flyback" PWM switch-mode supply of 12 V, one precision 3.3 V reference and one 5 V low drop out (LDO) linear regulator output.

Switch-mode supply output current capabilities depend on external components (can be selected to exceed 10 A). In the standard application circuit illustrated in Figure 1, each buck converter is capable of delivering 5 A, with the flyback converter delivering 250 mA. The recommended load currents for the precision 3.3 V reference output is less than 1 mA, and the 5 V LDO output is less than 30 mA. In order to maximize power efficiency of the converter, when the 5 V buck converter output (FB5) voltage is above 4.5 V, the internal 5 V LDO is turned off and  $V_L$  is supplied by the 5 V converter output.

### Buck Converter Operation:

The 3.3 V and 5 V buck converters are both current-mode PWM and PSM (during light load operation) regulators using high-side bootstrap N-Channel and low-side N-Channel MOSFETs. At light load conditions, the converters switch at a lower frequency than the clock frequency, seen like some clock pulses between the actual switching are skipped, this operating condition is defined as pulse-skipping. The operation of the converter(s) switching at clock frequency is defined as normal operation.

## DESCRIPTION OF OPERATION (CONT'D)

### Normal Operation: Buck Converters

In normal operation, the buck converter high-side MOSFET is turned on with a delay (known as break-before-make time -  $t_{BBM}$ ), after the rising edge of the clock. After a certain on time, the high-side MOSFET is turned off and then after a delay ( $t_{BBM}$ ), the low-side MOSFET is turned on until the next rising edge of the clock, or the inductor current reaches zero. The  $t_{BBM}$  (approximately 25 ns to 60 ns), has been optimized to guarantee the efficiency is not adversely affected at the high switching frequency and a specified minimum to account for variations of possible MOSFET gate capacitances.

During the normal operation, the high-side MOSFET switch on-time is controlled internally to provide excellent line and load regulation over temperature. Both buck converters should have load, line, regulation to within 0.5 % tolerance.

### Pulse Skipping: Buck Converters

When the buck converter switching frequency is less than the internal clock frequency, its operation mode is defined as pulse skipping mode. During this mode, the high-side MOSFET is turned on until  $V_{CS}-V_{FB}$  reaches 20 mV, or the on time reaches its maximum duty ratio. After the high-side MOSFET is turned off, the low-side MOSFET is turned on after the  $t_{BBM}$  delay, which will remain on until the inductor current reaches zero. The output voltage will rise slightly above the regulation voltage after this sequence, causing the controller to stay idle for the next one, or several clock cycles. When the output voltage falls slightly below the regulation level, the high-side MOSFET will be turned on again at the next clock cycle. With the converter remaining idle during some clock cycles, the switching losses are reduced in order to preserve conversion efficiency during the light output current condition.

### Current Limit: Buck Converters

When the buck converter inductor current is too high, the voltage across pin CS3(5) and pin FB3(5) exceeds approximately 120 mV, the high-side MOSFET would be turned off instantaneously regardless of the input, or output condition. The Si9136 features clock cycle by clock cycle current limiting capability.

### Flyback Converter Operation:

Designed mainly for PCMCIA or EEPROM programming, the Si9136 has a 12 V output non-isolated buck boost converter, called for brevity a flyback.

It consists of two N-Channel MOSFET switches that are turned on and off in phase, and two diodes. Similar to the buck converter, during the light load conditions, the flyback converter will switch at a frequency lower than the internal clock frequency, which can be defined as pulse skipping mode (PSM); otherwise, it is operating in normal PWM mode.

### Normal Operation: Flyback Converter

In normal operation mode, the two MOSFETs are turned on at the rising edge of the clock, and then turned off. The on time is controlled internally to provide excellent load, line, and temperature regulation. The flyback converter has load, line and temperature regulation well within 0.5 %.

### Pulse Skipping: Flyback Converter

Under the light load conditions, similar to the buck converter, the flyback converter will enter pulse skipping mode. The MOSFETs will be turned on until the inductor current increases to such a level that the voltage across the pin CSP and pin CSN reaches 100 mV, or the on time reaches the maximum duty cycle. After the MOSFETs are turned off, the inductor current will conduct through two diodes until it reaches zero. At this point, the flyback converter output will rise slightly above the regulation level, and the converter will stay idle for one or several clock cycle(s) until the output falls back slightly below the regulation level. The switching losses are reduced by skipping pulses and so the efficiency during light load is preserved.

### Current Limit: Flyback Converter

Similar to the buck converter; when the voltage across pin CSP and pin CSN exceeds 410 mV typical, the two MOSFETs will be turned off regardless of the input and output conditions.

### Flyback Lowside Drive

Unlike the gate drive for the two buck converters, the flyback lowside gate drive DLFY is powered by a voltage that can be as high as 15 V with 20 V input for the flyback converter. If this poses concerns on the MOSFET  $V_{GS}$  rating, a simple resistor-zener circuit can be used: a resistor series with gate and zener diode across the gate and source to clamp its voltage. A 100  $\Omega$ , 10 V combination works well.

## DESCRIPTION OF OPERATION (CONT'D)

### Grounding:

There are two separate grounds on the Si9136, analog signal ground (GND) and power ground (PGND). The purpose of two separate grounds is to prevent the high currents on the power devices (both external and internal) from interfering with the analog signals. The internal components of Si9136 have their grounds tied (internally) together. These two grounds are then tied together (externally) at a single point, to ensure Si9136 noise immunity.

This separation of grounds should be maintained in the external circuitry, with the power ground of all power devices being returned directly to the input capacitors, and the small signal ground being returned to the GND pin of Si9136.

### ON/OFF Function

Logic-low shuts off the appropriate section by disabling the gate drive stage. High-side and low-side gate drivers are turned off when ON/OFF pins are logic-low. Logic-high enables the DH and DL pins.

### Stability:

#### Buck Converters:

In order to simplify designs, the Si9136 requires no specified external components except load capacitors for stability control. Meanwhile, it achieves excellent regulation and

efficiency. The converters are current mode control, with a bandwidth substantially higher than the LC tank dominant pole frequency of the output filter. To ensure stability, the minimum capacitance and maximum ESR values are:

$$C_{LOAD} \geq \frac{V_{REF}}{2\pi \times V_{OUT} \times R_{CS} \times BW} \quad ESR \leq \frac{V_{OUT} \times R_{CS}}{V_{REF}}$$

Where  $V_{REF} = 3.3 \text{ V}$ ,  $V_{OUT}$  is the output voltage (5 V or 3.3 V),  $R_{CS}$  is the current sensing resistor in ohms and  $BW = 50 \text{ kHz}$

With the components specified in the application circuit ( $L = 10 \mu\text{H}$ ,  $R_{CS} = 0.02 \Omega$ ,  $C_{OUT} = 330 \mu\text{F}$ , ESR approximately  $0.1 \Omega$ , the converter should have a bandwidth at approximately 50 kHz, with minimum phase margin of  $65^\circ$ , and dc gain above 50 dB.

### Other Outputs

The Si9136 also provides a 3.3 V reference which can be external loaded up to 1 mA, as well as, a 5 V LDO output which can be loaded 30 mA, or even more depending on the system application. When the 5 V buck converter is turned on, the 5 V LDO output is shorted with the 5 V buck converter output, so its loading capability is substantially increased. For stability, the 3.3 V reference output requires a  $1 \mu\text{F}$  capacitor, and 5 V LDO output requires a  $4.7 \mu\text{F}$  capacitor.

*Vishay Siliconix maintains worldwide manufacturing capability. Products may be manufactured at one of several qualified locations. Reliability data for Silicon Technology and Package Reliability represent a composite of all qualified locations. For related documents such as package/tape drawings, part marking, and reliability data, see [www.vishay.com/ppg?70818](http://www.vishay.com/ppg?70818).*

### SSOP: 28-LEAD (5.3 MM) (POWER IC ONLY)

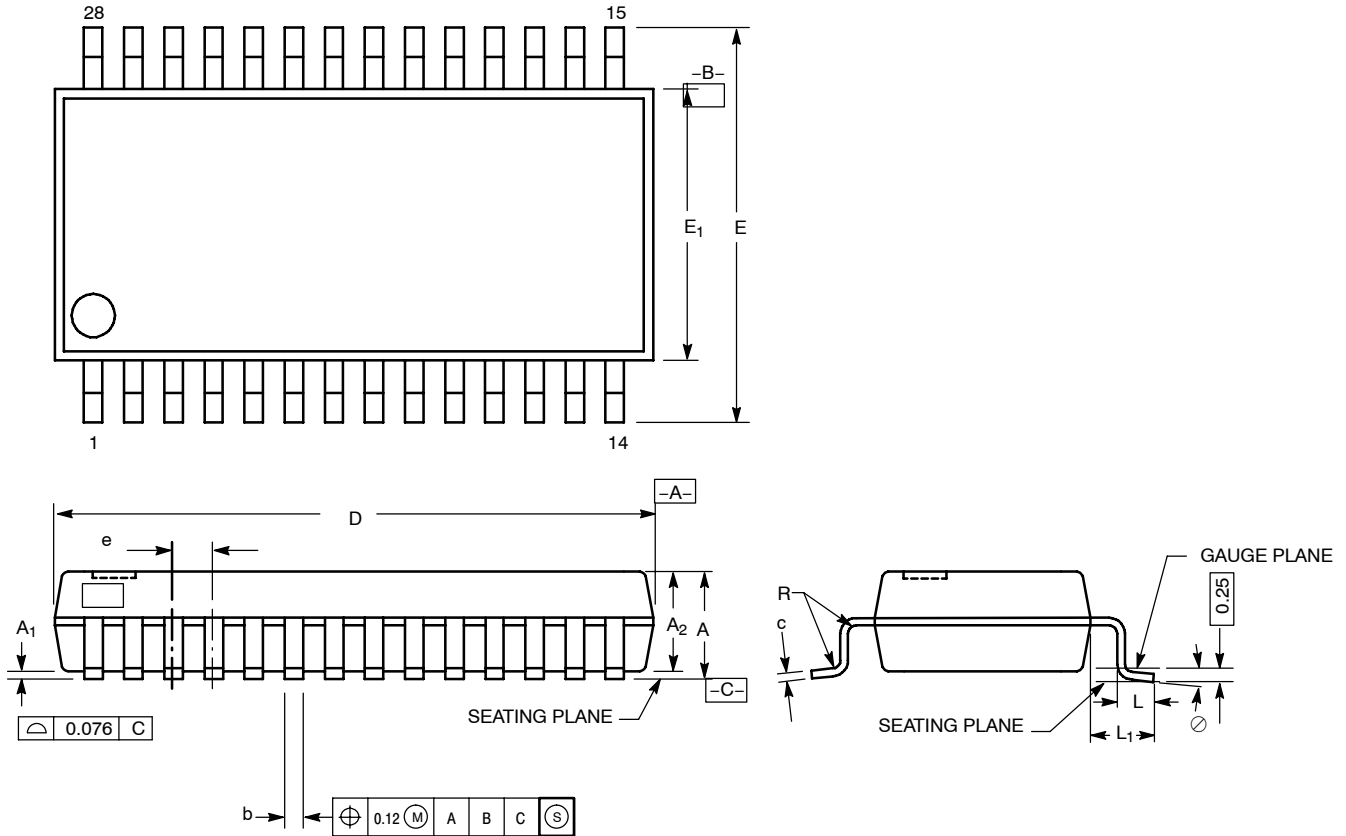

Dim	MILLIMETERS		
	Min	Nom	Max
A	1.73	1.88	1.99
A <sub>1</sub>	0.05	0.13	0.21
A <sub>2</sub>	1.68	1.75	1.78
b	0.25	0.30	0.38
c	0.09	0.15	0.20
D	10.07	10.20	10.33
E	7.60	7.80	8.00
E <sub>1</sub>	5.20	5.30	5.40
e	0.65 BSC		
L	0.63	0.75	0.95
L <sub>1</sub>	1.25 BSC		
R	0.09	0.15	---
∅	0°	4°	8°

ECN: S-40080—Rev. A, 02-Feb-04  
DWG: 5915



## Disclaimer

ALL PRODUCT, PRODUCT SPECIFICATIONS AND DATA ARE SUBJECT TO CHANGE WITHOUT NOTICE TO IMPROVE RELIABILITY, FUNCTION OR DESIGN OR OTHERWISE.

Vishay Intertechnology, Inc., its affiliates, agents, and employees, and all persons acting on its or their behalf (collectively, "Vishay"), disclaim any and all liability for any errors, inaccuracies or incompleteness contained in any datasheet or in any other disclosure relating to any product.

Vishay makes no warranty, representation or guarantee regarding the suitability of the products for any particular purpose or the continuing production of any product. To the maximum extent permitted by applicable law, Vishay disclaims (i) any and all liability arising out of the application or use of any product, (ii) any and all liability, including without limitation special, consequential or incidental damages, and (iii) any and all implied warranties, including warranties of fitness for particular purpose, non-infringement and merchantability.

Statements regarding the suitability of products for certain types of applications are based on Vishay's knowledge of typical requirements that are often placed on Vishay products in generic applications. Such statements are not binding statements about the suitability of products for a particular application. It is the customer's responsibility to validate that a particular product with the properties described in the product specification is suitable for use in a particular application. Parameters provided in datasheets and/or specifications may vary in different applications and performance may vary over time. All operating parameters, including typical parameters, must be validated for each customer application by the customer's technical experts. Product specifications do not expand or otherwise modify Vishay's terms and conditions of purchase, including but not limited to the warranty expressed therein.

Except as expressly indicated in writing, Vishay products are not designed for use in medical, life-saving, or life-sustaining applications or for any other application in which the failure of the Vishay product could result in personal injury or death. Customers using or selling Vishay products not expressly indicated for use in such applications do so at their own risk and agree to fully indemnify and hold Vishay and its distributors harmless from and against any and all claims, liabilities, expenses and damages arising or resulting in connection with such use or sale, including attorneys fees, even if such claim alleges that Vishay or its distributor was negligent regarding the design or manufacture of the part. Please contact authorized Vishay personnel to obtain written terms and conditions regarding products designed for such applications.

No license, express or implied, by estoppel or otherwise, to any intellectual property rights is granted by this document or by any conduct of Vishay. Product names and markings noted herein may be trademarks of their respective owners.





Компания «ЭлектроПласт» предлагает заключение долгосрочных отношений при поставках импортных электронных компонентов на взаимовыгодных условиях!

Наши преимущества:

- Оперативные поставки широкого спектра электронных компонентов отечественного и импортного производства напрямую от производителей и с крупнейших мировых складов;
- Поставка более 17-ти миллионов наименований электронных компонентов;
- Поставка сложных, дефицитных, либо снятых с производства позиций;
- Оперативные сроки поставки под заказ (от 5 рабочих дней);
- Экспресс доставка в любую точку России;
- Техническая поддержка проекта, помощь в подборе аналогов, поставка прототипов;
- Система менеджмента качества сертифицирована по Международному стандарту ISO 9001;
- Лицензия ФСБ на осуществление работ с использованием сведений, составляющих государственную тайну;
- Поставка специализированных компонентов (Xilinx, Altera, Analog Devices, Intersil, Interpoint, Microsemi, Aeroflex, Peregrine, Syfer, Eurofarad, Texas Instrument, Miteq, Cobham, E2V, MA-COM, Hittite, Mini-Circuits, General Dynamics и др.);

Помимо этого, одним из направлений компании «ЭлектроПласт» является направление «Источники питания». Мы предлагаем Вам помощь Конструкторского отдела:

- Подбор оптимального решения, техническое обоснование при выборе компонента;
- Подбор аналогов;
- Консультации по применению компонента;
- Поставка образцов и прототипов;
- Техническая поддержка проекта;
- Защита от снятия компонента с производства.



#### Как с нами связаться

**Телефон:** 8 (812) 309 58 32 (многоканальный)

**Факс:** 8 (812) 320-02-42

**Электронная почта:** [org@eplast1.ru](mailto:org@eplast1.ru)

**Адрес:** 198099, г. Санкт-Петербург, ул. Калинина, дом 2, корпус 4, литера А.