

LOC	DIST	REVISIONS				
		REV	DESCRIPTION	DATE	DWN	APVD
		B	REV PER ECO-08-032072	15JAN2009	CR	PD
		C	REV PER ECO-10-019210	04NOV2010	RG	MS

1. PART NUMBER CHANGES AND OR DESIGN CHANGES AFFECTING ITEM INTERCHANGEABILITY REQUIRE PRIOR TYCO ELECTRONICS APPROVAL AND AUTHORIZATION BY REVISION TO THIS DRAWING.

2. MATERIALS:
 INSULATORS: THERMOPLASTIC, GLASS REINFORCED
 UL94V-0 FLAMMABILITY RATED.
 CONTACTS: COPPER ALLOY

3. FINISHES:
 CONTACT PLATING: SELECTIVE GOLD: 0.76µm MIN THK
 OVER NICKEL: 1.27µm MIN THK
 TERMINALS: TIN: 1.78µm THK
 OVER NICKEL: 1.27µm MIN THK

4. CONNECTOR ACCEPTS 1.57±.13 THK PCB.

5. KEEP OUT AREA FOR COMPONENTS ONLY.

6. RECOMMENDED PRINTED CIRCUIT HOLE
 FINISHED HOLE: Ø1.02±.08
 DRILLED HOLE: Ø1.15±.013
 COPPER PLATE: .025 MINIMUM (PER SURFACE)
 TIN PLATE: .008 MINIMUM (PER SURFACE)

7. FEATURE REQUIRED FOR USE WITH LATCH.

8. CAUTION: LATCHES ARE INTENDED FOR RETENTION OF PC BOARD TO CONNECTOR. DO NOT ATTEMPT TO FULLY EJECT PC BOARD FROM CONNECTOR WHILE DISENGAGING LATCHES. DAMAGE TO LATCHES AND OR CONNECTOR MAY OCCUR.

9. RECOMMENDED GOLD FINGER LENGTH FOR RELIABLE CONTACT.

10. ITEMS PROVIDED TO THIS SPECIFICATION TO BE PERMANENTLY IDENTIFIED PER THE FOLLOWING IDENTIFIER:

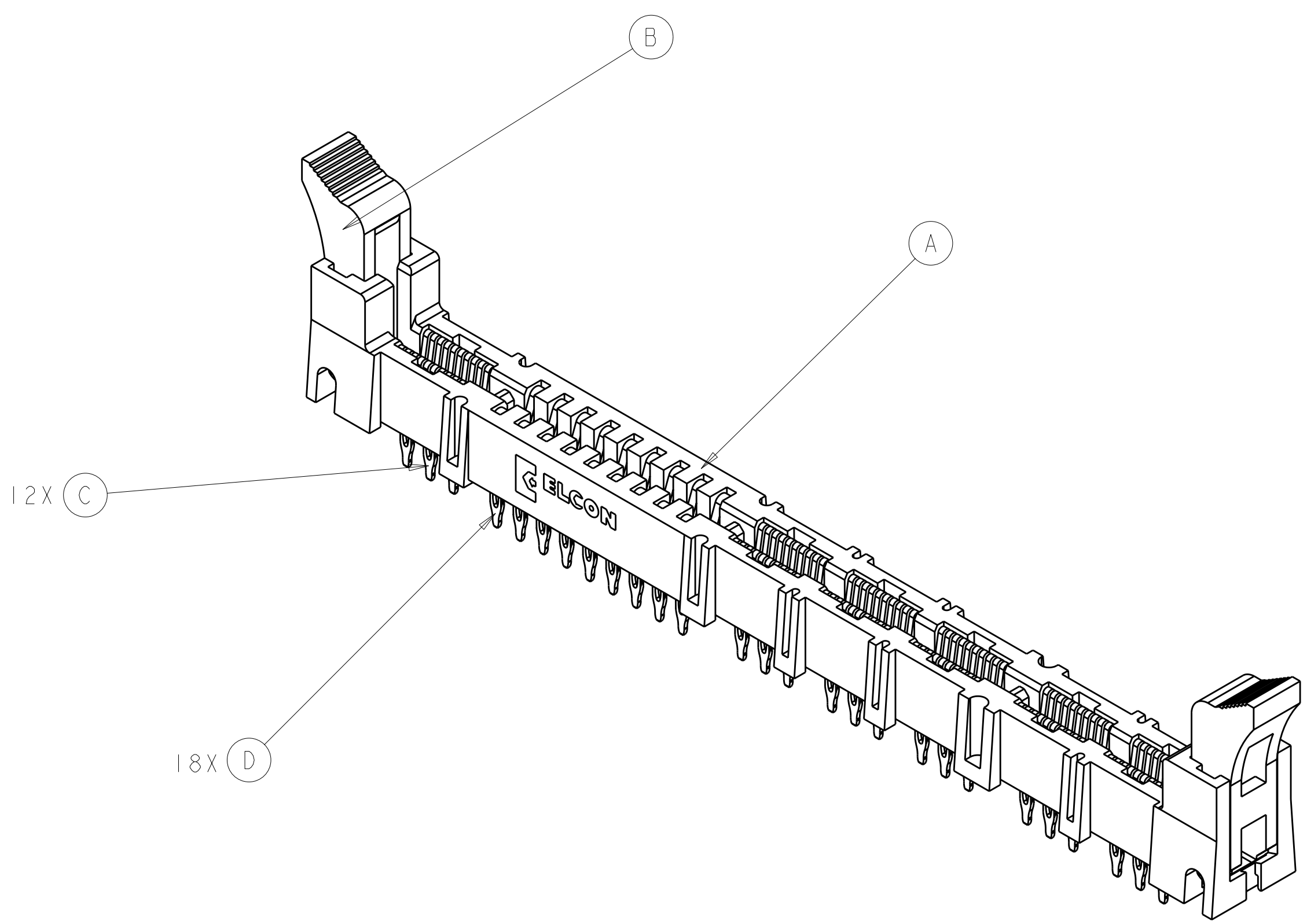
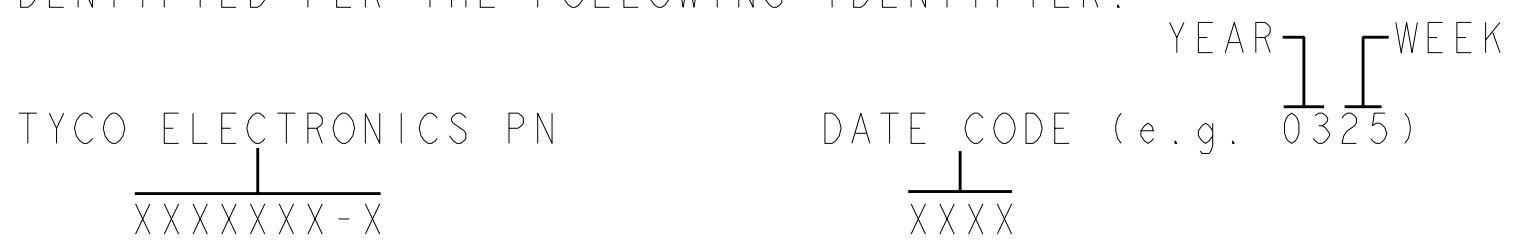

ITEM	QTY	PART NO.	DESCRIPTION	ITEM
18		1651808-2	CONTACT, SIGNAL	D
12		1651807-2	CONTACT, POWER	C
2		1651724-1	MINI-CROWNEDGE LATCH	B
1		1651723-1	HSG, SKT, MC-P6S9, MINI-CROWNEDGE	A
-1			PART NO. DESCRIPTION	ITEM

DIMENSIONS: mm 		TOLERANCES UNLESS OTHERWISE SPECIFIED: 9 PLC ±.5 1 PLC ±.5 5 PLC ±.25 4 PLC ±. ANGLES ±.5 FINISH: 3		DWN: C. ROHLER 15JAN2009 CHK: P. DAMATO 15JAN2009 APVD: M. PERCHERKE 15JAN2009		Tyco Electronics Harrisburg, PA 17105-3608	
MATERIAL: 2		WEIGHT: -		NAME: TOP ASSEM MC-P6S9, SOCKET CONNECTOR MINI CROWN EDGE, W/LATCHES, COMPLIANT PN 283-0172-04003		SIZE: A CAGE CODE: 00779 DRAWING NO: C=1766436	
CUSTOMER DRAWING				SCALE: 1:1		SHEET 1 OF 4 REV C	

LOC		DIST		REVISIONS			
P	LTB	DESCRIPTION	DATE	DWN	APVD		
-	-	SEE SHEET 1	-	-	-		

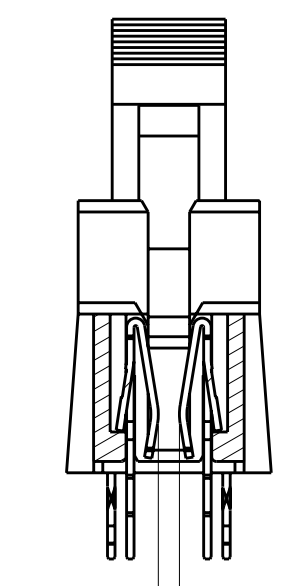
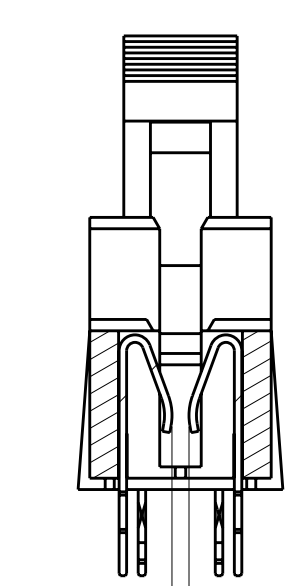
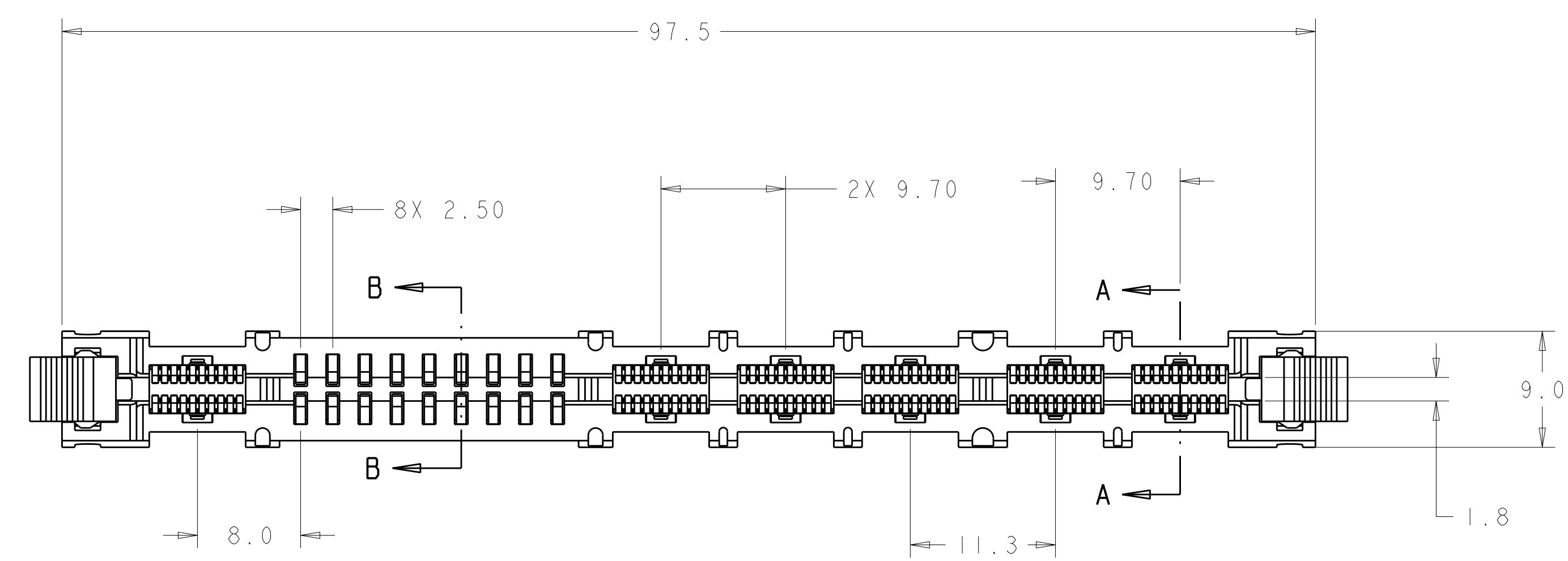

0.75 ± 0.10
 0.93^{+0.08}_{-0.24}

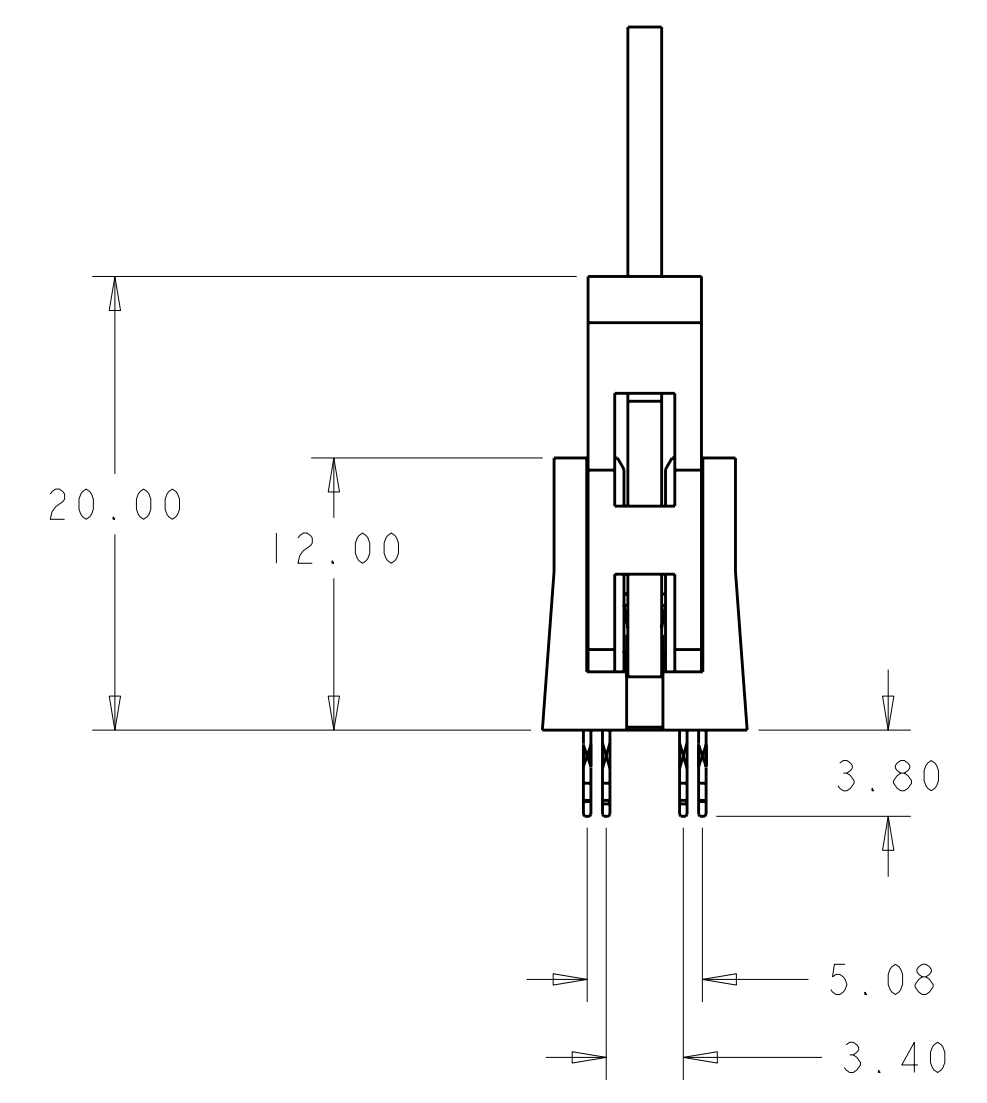
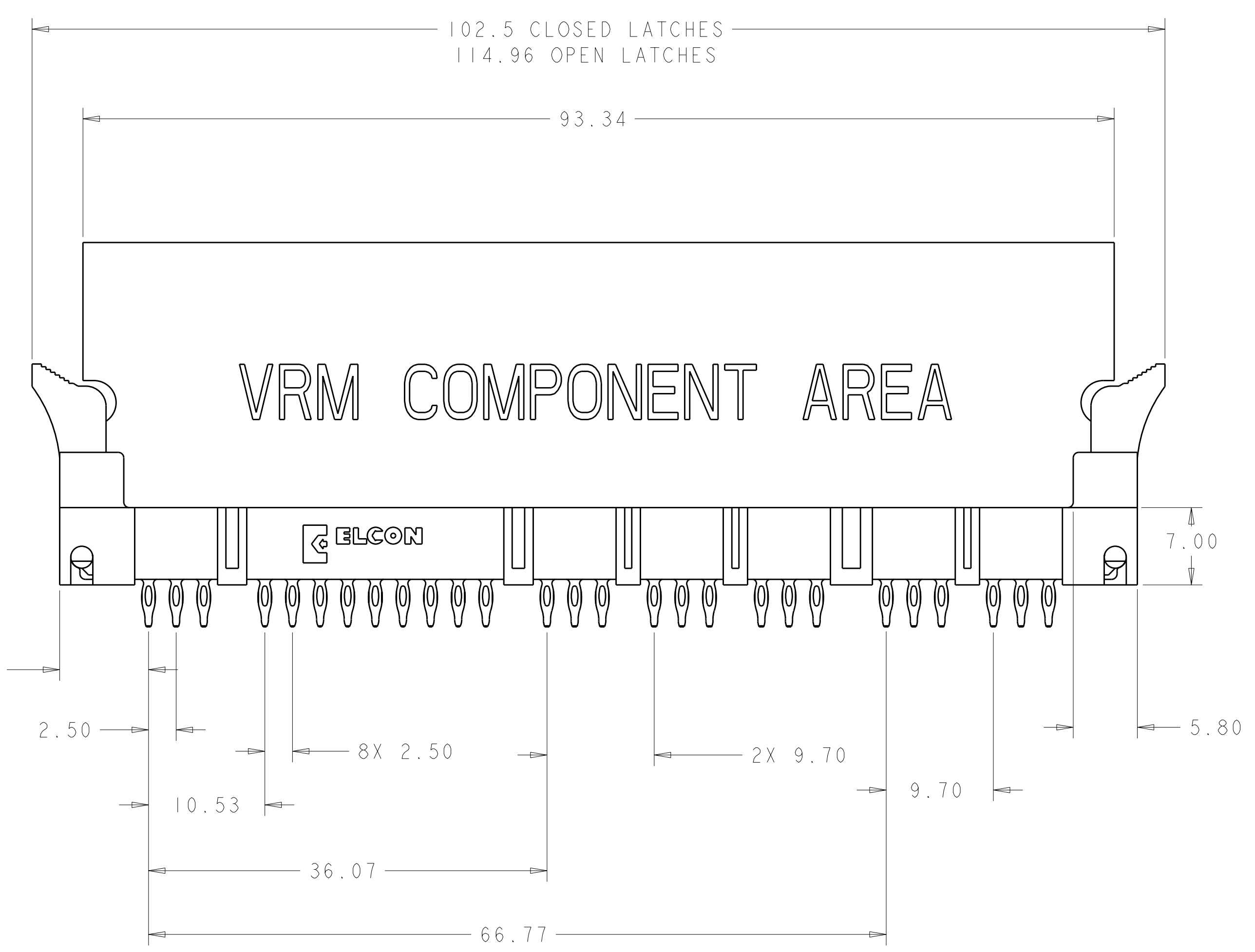

<small>THIS DRAWING IS UNPUBLISHED. RELEASED FOR PUBLICATION. THIS IS SUBJECT TO CHANGE WITHOUT NOTICE AND WITHOUT LIABILITY. DIMENSIONS ARE IN MILLIMETERS UNLESS OTHERWISE SPECIFIED. CONTACT TYCO ELECTRONICS CORPORATION FOR THE LATEST REVISION.</small>		DWN: C. ROHLER 15JAN2009 CHK: P. DAMATO 15JAN2009 APVD: M. PERCHERKE 15JAN2009	Tyco Electronics Harrisburg, PA 17105-3608
DIMENSIONS: mm 	TOLERANCES UNLESS OTHERWISE SPECIFIED: 0 PLC ±.5 1 PLC ±.5 2 PLC ±.25 3 PLC ±.5 4 PLC ±.5 ANGLES ±.5 FINISH	NAME: TOP ASSEM MC-P6S9, SOCKET CONNECTOR PRODUCT SPEC: MINI CROWN EDGE, W/LATCHES, COMPLIANT APPLICATION SPEC: PN 283-0172-04003 SIZE: A100779 CAGE CODE: C=1766436 DRAWING NO:	RESTRICTED TO:
MATERIAL:	FINISH:	WEIGHT:	CUSTOMER DRAWING
SCALE: 1:1		SHEET 2 OF 4 REV C	

LOC	DIST	REV	DESCRIPTION	DATE	DWN	APVD
-	-	1	SEE SHEET 1	-	-	-

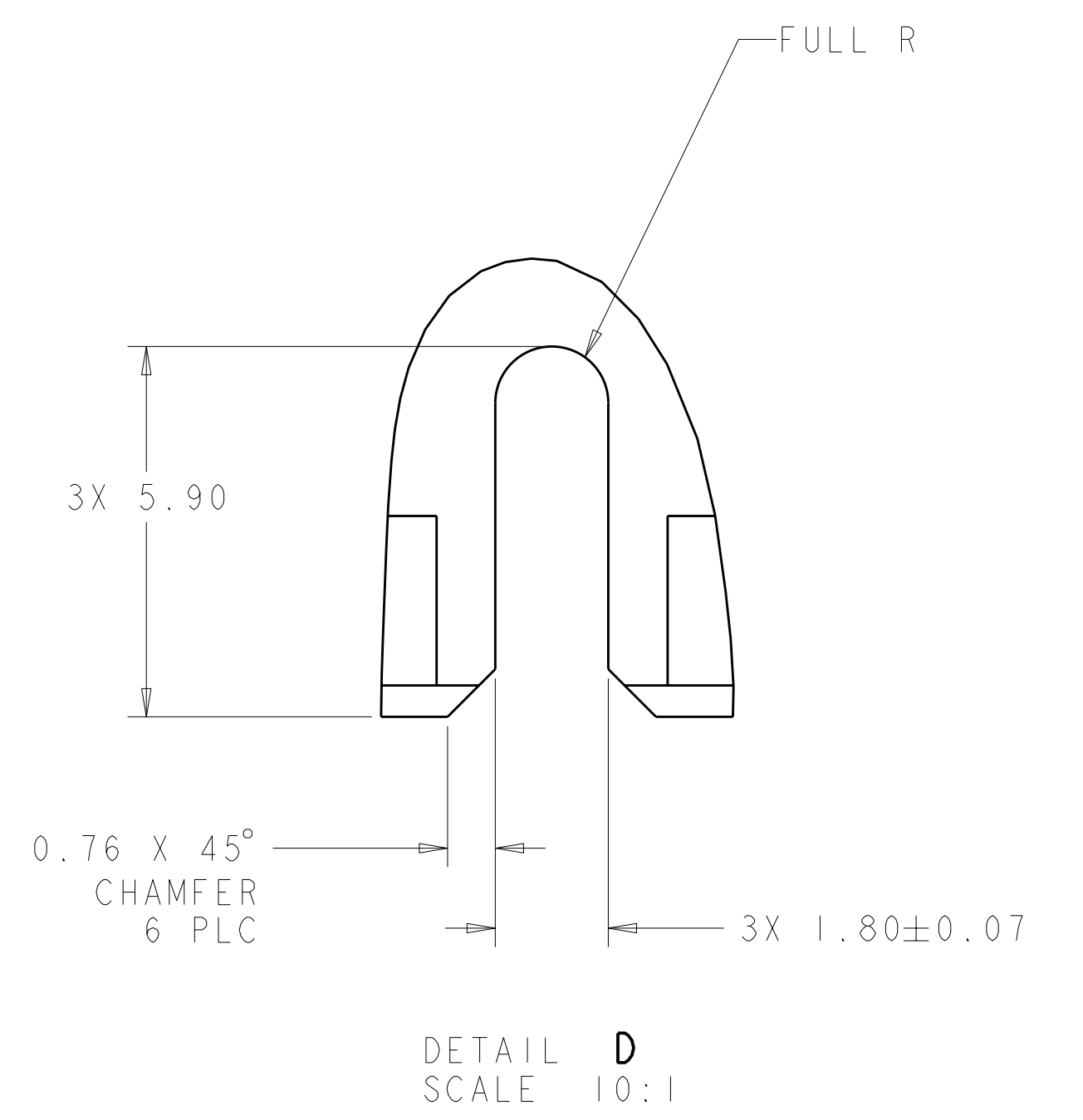
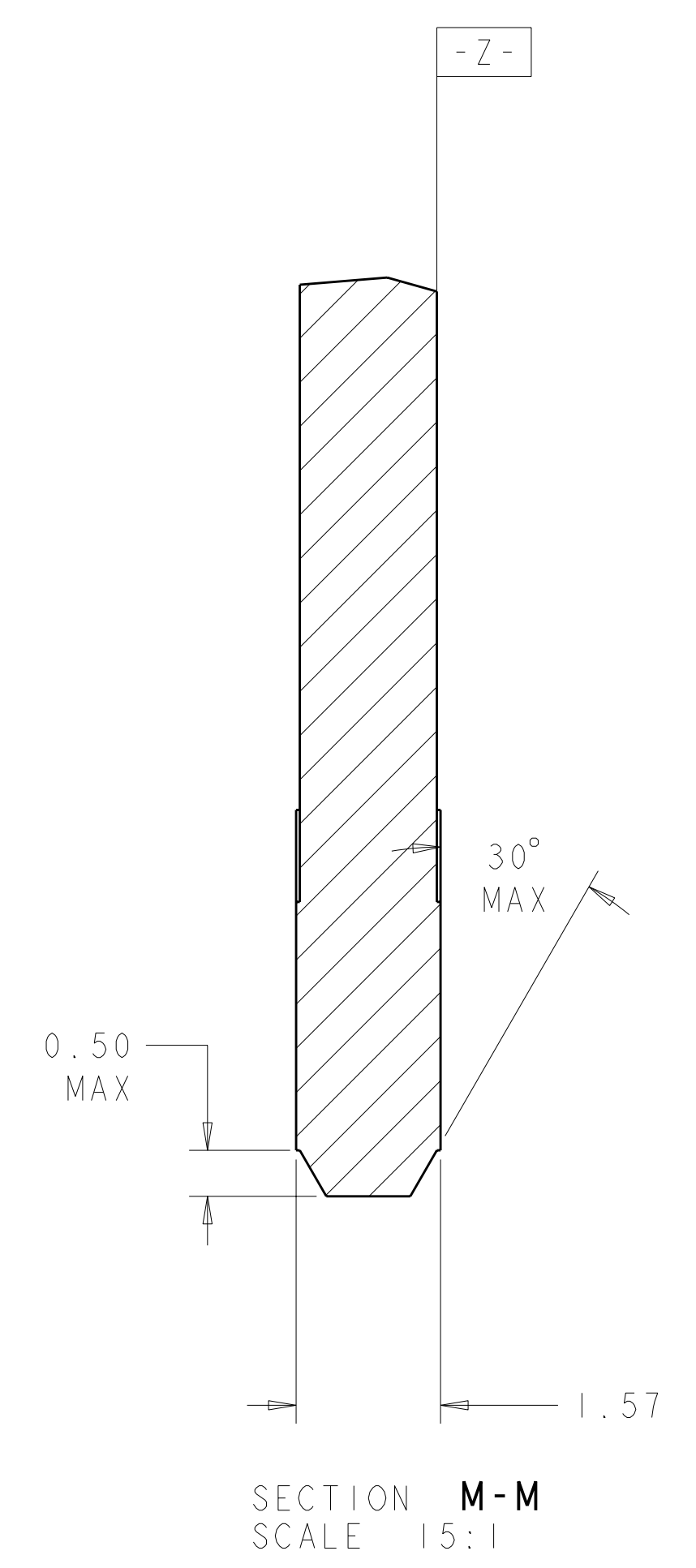
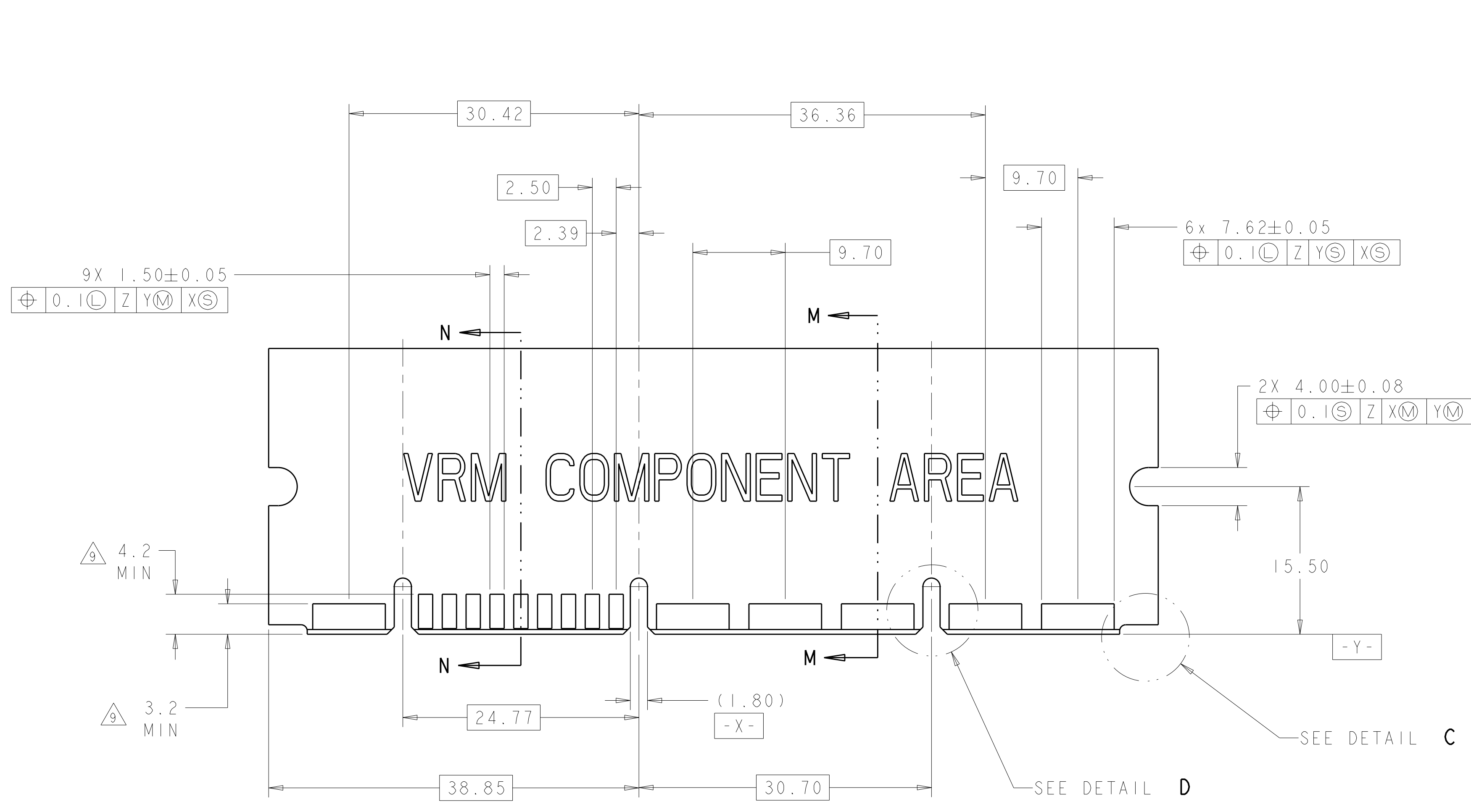

RECOMMENDED MATING BOARD

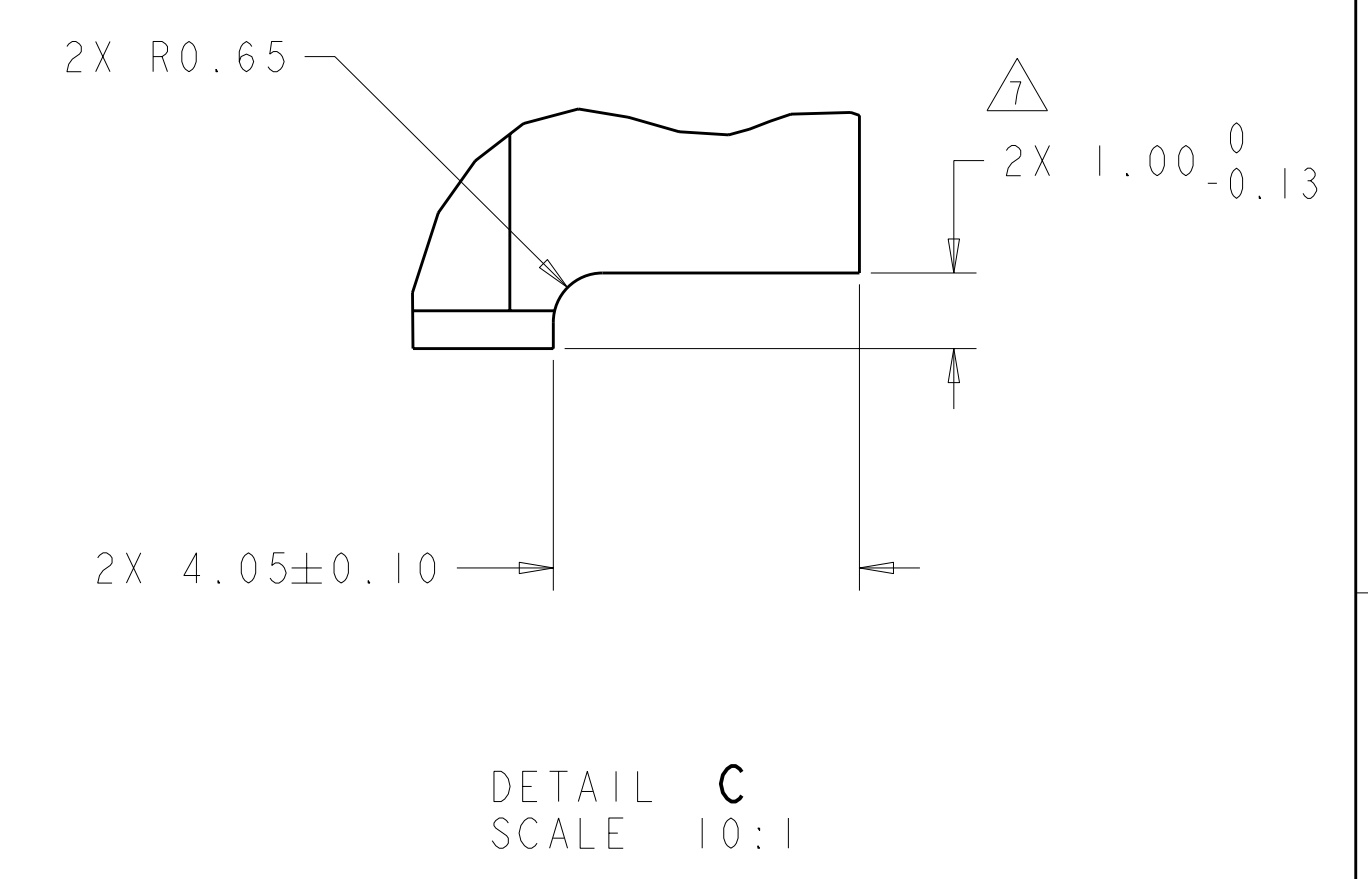
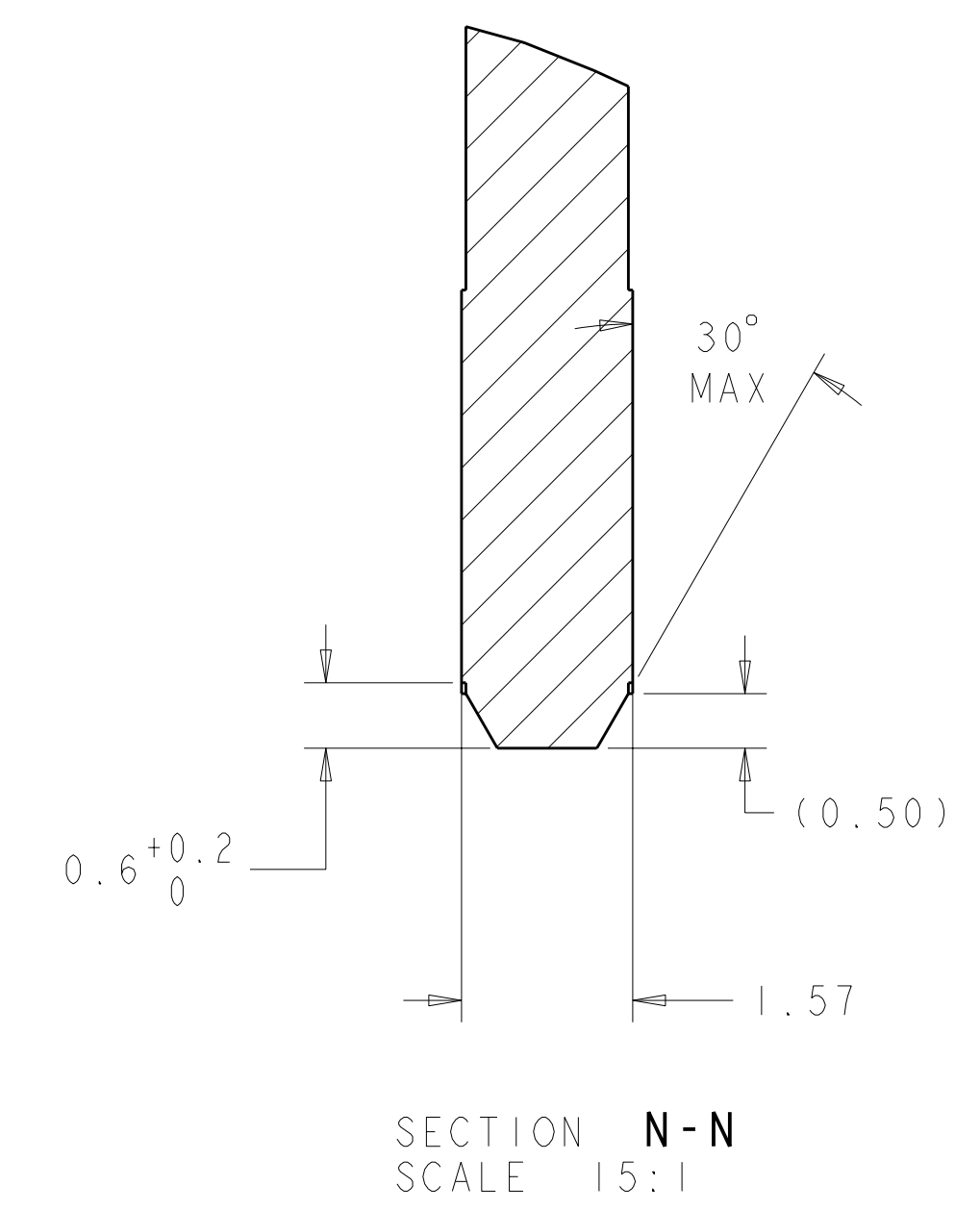
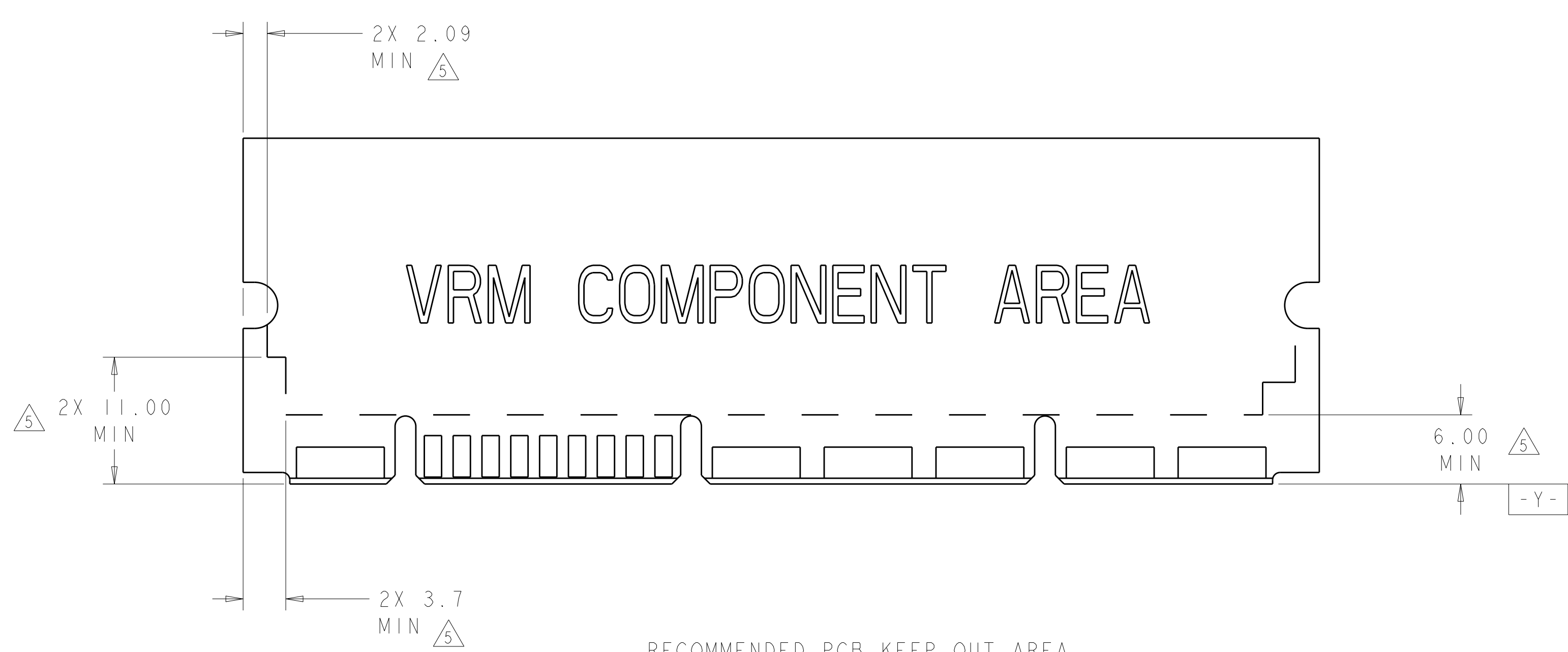

RECOMMENDED PCB KEEP OUT AREA

DIMENSIONS: mm 		TOLERANCES UNLESS OTHERWISE SPECIFIED: 9 PLC ±.5 5 PLC ±.25 4 PLC ±.5 ANGLES ±.5 FINISH		DWN C. ROHLER 15JAN2009 CHK P. DAMATO 15JAN2009 APVD M. PERCHERKE 15JAN2009 PRODUCT SPEC APPLICATION SPEC WEIGHT CUSTOMER DRAWING		Tyco Electronics Harrisburg, PA 17105-3608 NAME: TOP ASSEM MC-P6S9, SOCKET CONNECTOR MINI CROWN EDGE, W/LATCHES, COMPLIANT PN 283-0172-04003 SIZE: A1100779 CAGE CODE: 1766436 SCALE: 1:1 SHEET: 3 OF 4 REV: C	
-----------------------	--	--	--	---	--	---	--

LOC		DIST		REVISIONS			
NO.	REV.	DATE	BY	DESCRIPTION	DATE	DWN	APVD
-	-	-	-	SEE SHEET 1	-	-	-

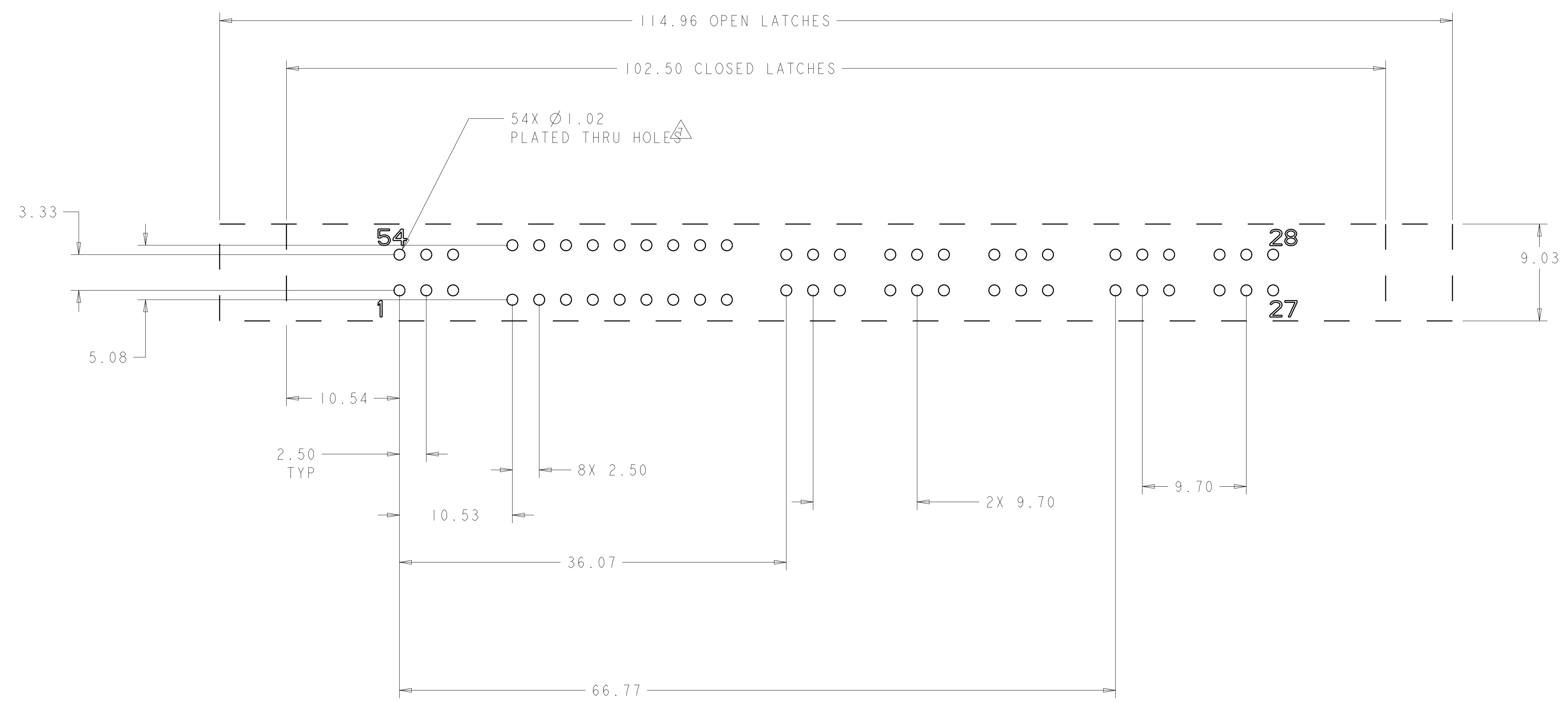

RECOMMENDED PC LAYOUT (VIEW FROM CONNECTOR SIDE)
 SCALE 4:1

<small>THIS DRAWING IS UNPUBLISHED. RELEASED FOR PUBLICATION. ALL RIGHTS RESERVED. THIS DRAWING IS UNPUBLISHED. RELEASED FOR PUBLICATION. ALL RIGHTS RESERVED. THIS DRAWING IS UNPUBLISHED. RELEASED FOR PUBLICATION. ALL RIGHTS RESERVED.</small>		DWN C. ROHLER 15JAN2009	Tyco Electronics Harrisburg, PA 17105-3608
DIMENSIONS: mm 		TOLERANCES UNLESS OTHERWISE SPECIFIED: 0 PLC ±.5 1 PLC ±.5 2 PLC ±.25 3 PLC ±.5 4 PLC ±.5 ANGLES ±.5 FINISH	Tyco Electronics NAME: TOP ASSEM MC-P6S9, SOCKET CONNECTOR MINI CROWN EDGE, W/LATCHES, COMPLIANT PN 283-0172-04003 SIZE: A 00779 C=1766436 SCALE: 4:1 SHEET 4 OF 4 REV C
MATERIAL: - FINISH: -		CHECKED: P. DAMATO 15JAN2009 APVD: M. PERCHERKE 15JAN2009 PRODUCT SPEC: APPLICATION SPEC: WEIGHT: - CUSTOMER DRAWING	RESTRICTED TO: -



Компания «ЭлектроПласт» предлагает заключение долгосрочных отношений при поставках импортных электронных компонентов на взаимовыгодных условиях!

Наши преимущества:

- Оперативные поставки широкого спектра электронных компонентов отечественного и импортного производства напрямую от производителей и с крупнейших мировых складов;
- Поставка более 17-ти миллионов наименований электронных компонентов;
- Поставка сложных, дефицитных, либо снятых с производства позиций;
- Оперативные сроки поставки под заказ (от 5 рабочих дней);
- Экспресс доставка в любую точку России;
- Техническая поддержка проекта, помощь в подборе аналогов, поставка прототипов;
- Система менеджмента качества сертифицирована по Международному стандарту ISO 9001;
- Лицензия ФСБ на осуществление работ с использованием сведений, составляющих государственную тайну;
- Поставка специализированных компонентов (Xilinx, Altera, Analog Devices, Intersil, Interpoint, Microsemi, Aeroflex, Peregrine, Syfer, Eurofarad, Texas Instrument, Miteq, Cobham, E2V, MA-COM, Hittite, Mini-Circuits, General Dynamics и др.);

Помимо этого, одним из направлений компании «ЭлектроПласт» является направление «Источники питания». Мы предлагаем Вам помощь Конструкторского отдела:

- Подбор оптимального решения, техническое обоснование при выборе компонента;
- Подбор аналогов;
- Консультации по применению компонента;
- Поставка образцов и прототипов;
- Техническая поддержка проекта;
- Защита от снятия компонента с производства.



Как с нами связаться

Телефон: 8 (812) 309 58 32 (многоканальный)

Факс: 8 (812) 320-02-42

Электронная почта: org@eplast1.ru

Адрес: 198099, г. Санкт-Петербург, ул. Калинина, дом 2, корпус 4, литера А.