

General Description

The SY88932L is the smallest available laser driver with a programmable modulation current up to 60mA for Fabry-Perot (FP) or distribution feedback (DFB) lasers. The device is suitable for SONET/SDH applications with data rates up to 4.25Gbps. The SY88932L accepts either CML level or AC-coupled PECL inputs, and incorporates an active low TTL /EN function which shuts off the modulation current when HIGH.

Datasheets and support documentation can be found on Micrel's web site at www.micrel.com.

Features

- Up to 4.25Gbps operation
- Modulation current to 60mA
- Rise/fall times 65ps typical
- Input 50Ω internally terminated to VCC
- TTL /EN with internal 75kΩ pull-down
- Designed for use with MIC3000 optical transceiver management IC
- Voltage programmable laser modulation current
- Single 3.3V power supply
- Operating temperature range of -40°C to +85°C
- Available in tiny 16-pin QFN package

Applications

- Fiber optical module
- Transponder
- XAUI CWDM
- SONET/ SDH transmission system
- Add-drop MUX
- Metro area network
- 4.25Gbps optical transmitter

Block Diagram

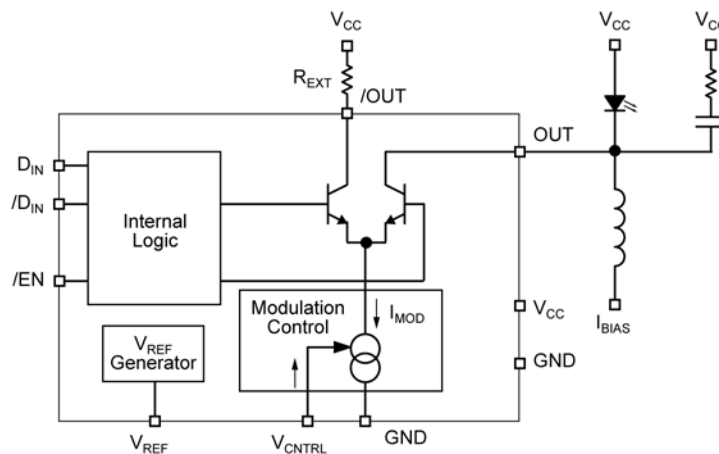

Ordering Information

Part Number	Package Type	Operating Range	Package Marking	Lead Finish
SY88932LMI	QFN-16	Industrial	932L	Sn-Pb
SY88932LMITR ⁽¹⁾	QFN-16	Industrial	932L	Sn-Pb
SY88932LMG	QFN-16	Industrial	932L with Pb-Free bar-line indicator	Pb-Free NiPdAu
SY88932LMGTR ⁽¹⁾	QFN-16	Industrial	932L with Pb-Free bar-line indicator	Pb-Free NiPdAu

Note:

1. Tape and Reel.

Pin Configuration

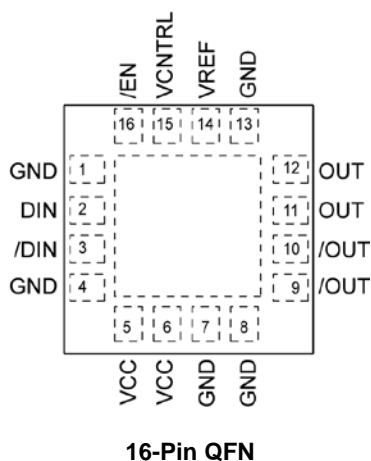

Pin Description

Pin Number	Pin Name	Pin Function
2, 3	DIN, /DIN	NRZ differential data (inputs), CML terminated interface with 50Ω to V _{CC} .
1, 4, 7, 8, 13	GND	Ground.
5, 6	VCC	Positive power supply.
9, 10, 11, 12	OUT, /OUT	Open collector (outputs) from the modulation driver.
14	VREF	Voltage reference, nominally 1.25V with respect to ground.
15	VCNTRL	Voltage control of I _{MOD} . 5kΩ input impedance. See "Typical Operating Characteristics."
16	/EN	Enable: TTL-compatible active low input with 75kΩ pull-down resistor.

Truth Table^(1,2)

D	/D	/EN	OUT ⁽³⁾	/OUT
L	H	L	H	L
H	L	L	L	H
X	X	H	H	L

Notes:

1. Truth table parameters are given for voltage rather than optical outputs. Hence, a voltage HIGH and OUT means no modulation current is flowing through OUT, and a voltage LOW on OUT means modulation current is flowing through OUT. A voltage LOW implies an optical HIGH, and vice versa.
2. L = LOW, H = HIGH, X = don't care.
3. I_{OUT} ≤ I_{MOD_OFF} when /EN is HIGH.

Absolute Maximum Ratings⁽¹⁾

Supply Voltage (V_{CC})	-0.5V to +4.0V
CML Input Voltage (V_{IN})	$V_{CC} - 1.0V$ to $V_{CC} + 0.5V$
TTL Control Input Voltage (V_{IN})	0V to V_{CC}
Lead Temperature (soldering, 20sec.)	265°C
Storage Temperature (T_s)	-65°C to +150°C

Operating Ratings⁽²⁾

Supply Voltage (V_{CC})	+3.0V to +3.6V
Ambient Temperature (T_A)	-40°C to +85°C
Junction Temperature (T_J)	-40°C to +120°C
Junction Thermal Resistance ⁽³⁾	
QFN	
(θ_{JA}) Still-Air	61°C/W
(ψ_{JB}) Still-Air	38°C/W

DC Electrical Characteristics

$V_{CC} = 3.0V$ to $3.6V$; $GND = 0V$; $T_A = -40^\circ C$ to $+85^\circ C$, Typical values at $V_{CC} = 3.3V$, $T_A = 25^\circ C$.

Symbol	Parameter	Condition	Min	Typ	Max	Units
I_{CC}	Power Supply Current	Note 4		57	80	mA
I_{MOD}	Modulation Current Range		10		60	mA
I_{MOD_OFF}	Modulation Off Current	/EN = V_{IHEN}			200	μA
V_{IR}	CML Input Voltage Range		$V_{CC} - 0.8$		$V_{CC} + 0.4$	V
V_{ID}	CML Input Differential Voltage (D_{IN} , / D_{IN})	Note 5	400	800	1600	mV _{PP}
V_{IHEN}	TTL Input HIGH Voltage (/EN)		2.0			V
V_{ILEN}	TTL Input LOW Voltage (/EN)				0.8	V
V_{OUT}	Voltage (OUT, /OUT)	Note 6	$V_{CC} - 1.5$		V_{CC}	V
V_{REF}	Reference Voltage	Note 7	1.2	1.25	1.3	V

Notes:

1. Permanent device damage may occur if Absolute Maximum Ratings are exceeded. This is a stress rating only and functional operation is not implied at conditions other than those detailed in the operational sections of this datasheet. Exposed to Absolute Maximum Ratings conditions for extended periods may affect device reliability.
2. The device is not guaranteed to function outside its operating rating.
3. Thermal resistance numbers are 4-layer PCB. Thermal performance assumes exposed pad is soldered (or equivalent) to the same potential as the ground pins on the PCB.
4. Excluding I_{MOD} . I_{MOD} set to 60mA with 25 Ω load to V_{CC} on OUT, /OUT. Inputs floating.
5. V_{ID} is the voltage required to guarantee a stable logic level. For logic "1", D_{IN} must be $V_{ID}/2$ above / D_{IN} . For stable logic "0", D_{IN} must be $V_{ID}/2$ below / D_{IN} .
6. OUT and /OUT are current outputs. This specification defines the voltage range that the user must guarantee these pins remain within for proper operation.
7. V_{REF} intended to source/sink $\leq |5mA|$.

AC Electrical Characteristics⁽⁸⁾

$V_{CC} = 3.0V$ to $3.6V$; $GND = 0V$; $T_A = -40^{\circ}C$ to $+85^{\circ}C$, Typical values at $V_{CC} = 3.3V$, $T_A = 25^{\circ}C$.

Symbol	Parameter	Condition	Min	Typ	Max	Units
t_r, t_f	Output Rise/Fall Times (20% to 80%)	Note 9		65	100	ps
DJ	Deterministic Jitter	Note 9, 10		20		pSPP

Notes:

- 8. AC characteristics are guaranteed by design and characterization.
- 9. $I_{MOD} = 60mA$.
- 10. Deterministic jitter measured using K28.5 pattern of 2.486Gbps, $V_{ID} = 1600mV_{PP}$.

Typical Operating Characteristics

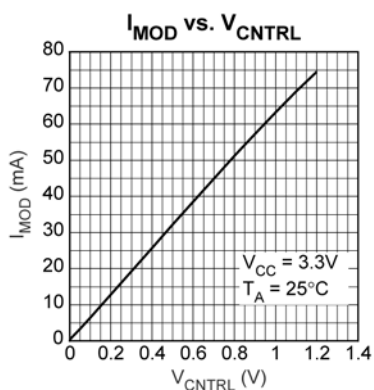

Package Information

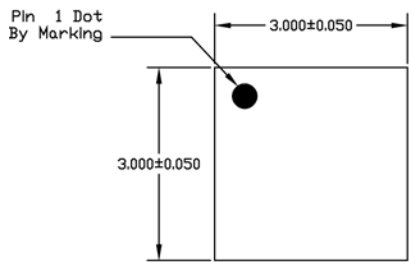

TOP VIEW

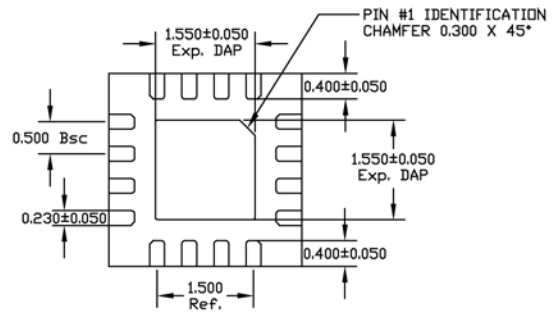

BOTTOM VIEW

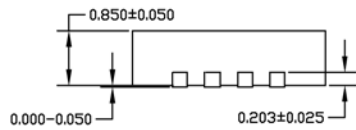

SIDE VIEW

NOTE:

1. ALL DIMENSIONS ARE IN MILLIMETERS.
2. MAX. PACKAGE WARPAGE IS 0.05 mm.
3. MAXIMUM ALLOWABLE BURRS IS 0.076 mm IN ALL DIRECTIONS.
4. PIN #1 ID ON TOP WILL BE LASER/INK MARKED.

16-Pin QFN

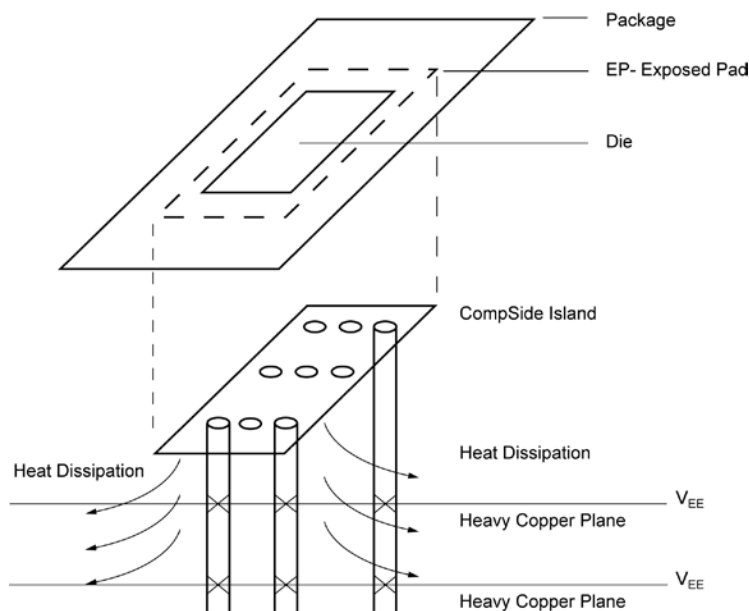

PCB Thermal Consideration for 16-Pin QFN Package

Package Notes:

1. Package meets Level 2 qualifications.
2. All parts are dry-packaged before shipment.
3. Exposed pads must be soldered to a ground for proper thermal management.

MICREL, INC. 2180 FORTUNE DRIVE SAN JOSE, CA 95131 USA
 TEL +1 (408) 944-0800 FAX +1 (408) 474-1000 WEB <http://www.micrel.com>

The information furnished by Micrel in this data sheet is believed to be accurate and reliable. However, no responsibility is assumed by Micrel for its use. Micrel reserves the right to change circuitry and specifications at any time without notification to the customer.

Micrel Products are not designed or authorized for use as components in life support appliances, devices or systems where malfunction of a product can reasonably be expected to result in personal injury. Life support devices or systems are devices or systems that (a) are intended for surgical implant into the body or (b) support or sustain life, and whose failure to perform can be reasonably expected to result in a significant injury to the user. A Purchaser's use or sale of Micrel Products for use in life support appliances, devices or systems is a Purchaser's own risk and Purchaser agrees to fully indemnify Micrel for any damages resulting from such use or sale.

© 2008 Micrel, Incorporated.



Компания «ЭлектроПласт» предлагает заключение долгосрочных отношений при поставках импортных электронных компонентов на взаимовыгодных условиях!

Наши преимущества:

- Оперативные поставки широкого спектра электронных компонентов отечественного и импортного производства напрямую от производителей и с крупнейших мировых складов;
- Поставка более 17-ти миллионов наименований электронных компонентов;
- Поставка сложных, дефицитных, либо снятых с производства позиций;
- Оперативные сроки поставки под заказ (от 5 рабочих дней);
- Экспресс доставка в любую точку России;
- Техническая поддержка проекта, помощь в подборе аналогов, поставка прототипов;
- Система менеджмента качества сертифицирована по Международному стандарту ISO 9001;
- Лицензия ФСБ на осуществление работ с использованием сведений, составляющих государственную тайну;
- Поставка специализированных компонентов (Xilinx, Altera, Analog Devices, Intersil, Interpoint, Microsemi, Aeroflex, Peregrine, Syfer, Eurofarad, Texas Instrument, Miteq, Cobham, E2V, MA-COM, Hittite, Mini-Circuits, General Dynamics и др.);

Помимо этого, одним из направлений компании «ЭлектроПласт» является направление «Источники питания». Мы предлагаем Вам помощь Конструкторского отдела:

- Подбор оптимального решения, техническое обоснование при выборе компонента;
- Подбор аналогов;
- Консультации по применению компонента;
- Поставка образцов и прототипов;
- Техническая поддержка проекта;
- Защита от снятия компонента с производства.



Как с нами связаться

Телефон: 8 (812) 309 58 32 (многоканальный)

Факс: 8 (812) 320-02-42

Электронная почта: org@eplast1.ru

Адрес: 198099, г. Санкт-Петербург, ул. Калинина, дом 2, корпус 4, литера А.