



MAX686 Evaluation Kit

Evaluates: MAX686

General Description

The MAX686 evaluation kit (EV kit) is a fully assembled and tested surface-mount circuit board that contains two separate switching-regulator circuits. The first circuit converts a +0.8V to +18V battery voltage to a +18V LCD bias voltage for currents up to 20mA. The second circuit converts a +0.8V to +12V battery voltage to a -17V voltage for currents up to 20mA.

The MAX686 requires a +2.7V to +5.5V supply at VIN, but the inductor can be powered from as low as +0.8V. The device features an internal N-channel MOSFET switch, programmable current limit, and internal 6-bit DAC for digital adjustment of the output voltage. The MAX686 EV kit provides low quiescent current and high efficiency for maximum battery life. Operation up to 300kHz allows the use of a tiny surface-mount inductor.

Ordering Information

PART	TEMP. RANGE	IC PACKAGE
MAX686EVKIT	0°C to +70°C	16 QSOP

Features

- ◆ **Output Voltage:**
 - +18V Typical Positive Output (or +12.6V to +24V adjustable with up/down)
 - 17V Typical Negative Output (or -22.7V to -11.4V adjustable with up/down)
- ◆ **Battery Input Voltage:**
 - +0.8V to +18V (Positive Output)
 - +0.8V to +12V (Negative Output)
- ◆ **+2.7V to +5.5V VIN Supply Range**
- ◆ **Up to 20mA Output Current**
- ◆ **6-Bit DAC-Controlled Output Voltage**
- ◆ **Internal 0.5A, 28V N-Channel Switch**
- ◆ **1.3µA IC Shutdown Current**
- ◆ **Up to 300kHz Switching Frequency**
- ◆ **Surface-Mount Components**
- ◆ **Fully Assembled and Tested**

Component List

DESIGNATION	QTY	DESCRIPTION
C1, C8	2	15µF, 35V tantalum capacitors AVX TPSD156M035R0300 or Sprague 593D156X0035E2W
C2	1	4.7µF, 35V tantalum capacitor AVX TPSC475M035R0600 or Sprague 595D475X0035C
C3	1	1µF ceramic capacitor
C4, C5, C11, C12, C13	5	0.1µF ceramic capacitors
C6	1	2.2µF, 25V ceramic capacitor United Chemi-Con/Marcon THCR30E1E225Z
C7	1	22pF ceramic capacitor
C9	1	2.2µF, 35V tantalum capacitor AVX TAJB225M035R or Sprague 595D225X0035B
C10	1	100pF ceramic capacitor
D1, D2, D3	3	Schottky diodes Motorola MBR0540T1

DESIGNATION	QTY	DESCRIPTION
D4	0	Not installed
L1, L2	2	22µH inductors Sumida CD54-220
R1, R9	2	1MΩ, 1% resistors
R2, R3, R10, R11	4	110kΩ, 1% resistors
R4, R5, R16, R17, Q1	0	Not installed
R6, R7, R8, R12 R13, R14	6	100kΩ, 5% resistors
R15	1	2Ω, 5% resistor
R18	1	100Ω, 5% resistor
U1, U2	2	MAX686EEE
JU1, JU4	2	3-pin headers
JU2, JU3, JU5, JU6	4	2-pin headers
None	2	Shunt
None	1	MAX686 PC board
None	1	MAX686 data sheet



MAX686 Evaluation Kit

Component Suppliers

SUPPLIER	PHONE	FAX
AVX	(803) 946-0690	(803) 626-3123
Coilcraft	(708) 639-6400	(708) 639-1469
Coiltronics	(561) 241-7876	(561) 241-9339
Dale-Vishay	(402) 564-3131	(402) 563-6418
Motorola	(602) 303-5454	(602) 994-6430
Sprague	(603) 224-1961	(603) 224-1430
Sumida	(708) 956-0666	(708) 956-0702
United Chemi-Con/ Marcon	(847) 696-2000	(847) 696-9278
Vishay/Vitramon	(203) 268-6261	(203) 452-5670

Note: Please indicate that you are using the MAX686 when contacting these component suppliers.

Quick Start

The MAX686 EV kit is fully assembled and tested. Follow these steps to verify board operation. VIN and VBATT are separated on each circuit to demonstrate operation of VBATT down to +0.8V. VIN and VBATT can be connected together and to a single supply from +2.7V to +5.5V via jumpers JU3 and JU6. **Do not turn on the power supply until all connections are completed.**

Positive Output

- 1) Connect a +2.7V to +5.5V supply to the VIN pad, and connect a +0.8V to +18V supply to the VBATT pad. Connect the grounds to the GND pads.
- 2) Connect a voltmeter and load, if any, to the VOUT pad.
- 3) Place the shunt on JU1 across pins 2 and 3.
- 4) Turn on the power supplies and verify that the output voltage is typically +18V.

Negative Output

- 1) Connect a +2.7V to +5.5V supply to the VIN pad, and connect a +0.8V to +12V supply to the VBATT pad. Connect the grounds to the GND pads.
- 2) Connect a voltmeter and load, if any, to the -VOUT pad.
- 3) Place the shunt on JU4 across pins 2 and 3.
- 4) Turn on the power supplies and verify that the output voltage is typically -17V.

For instructions on selecting the feedback resistors for other output voltages, refer to the *Setting the Output Voltage* section in the MAX686 data sheet.

Detailed Description

The MAX686 EV kit contains two separate switching-regulator circuits. The first circuit provides an +18V output for currents up to 20mA with 90% typical conversion efficiency. The second circuit provides a -17V output voltage for currents up to 20mA with 82% typical conversion efficiency. Both output voltages can be adjusted with the internal 6-bit DAC. Each output can be controlled by logic signals applied to the UP/DN pads.

Output Voltage Control

The output voltage is set with the combination of a voltage divider and a summing resistor from DACOUT. The 6-bit DAC is controlled with an up/down counter via the UP and DN pins. This EV kit has the UP and DN pins connected to ground via 100k Ω resistors (R7, R8, R13, R14). On power-up, the output voltage is set to mid-scale. A rising edge on UP increases the output voltage; a rising edge on DN decreases the output voltage. Holding both UP and DN high resets the output voltage to mid-scale. Refer to the section *Setting the Output Voltage* in the MAX686 data sheet for more information on controlling the MAX686 output voltage.

Controlling the LCD Using POK and LCDON

$\overline{\text{LCDON}}$ can be used to turn on a positive LCD bias voltage when VBATT is above the desired threshold. A resistor-divider (R16-R17) from VBATT to POK controls the open-drain output $\overline{\text{LCDON}}$, which pulls low when $V_{\text{POK}} > 1.125\text{V}$.

$\overline{\text{LCDON}}$ can drive an external PNP transistor, Q1, switching a positive V_{OUT} to the LCD. The EV kit provides additional pads for Q1, R4, and R5. Choose a PNP with low saturation voltage at the required load current.

R4 limits the base current in Q1. R5 is used to turn off Q1 when $\overline{\text{LCDON}}$ is floating. R4 and R5 can be the same value. Refer to the section *Controlling the LCD Using POK and LCDON* in the MAX686 data sheet for instructions on selecting resistors R4, R5, R16, and R17.

MAX686 Evaluation Kit

Evaluates: MAX686

Jumper Selection Shutdown Mode

The MAX686 EV kit features a shutdown mode that reduces the MAX686's quiescent current to 1.5 μ A (typical), preserving battery life. The 2-pin header JU1 selects the shutdown mode for the positive output, while JU4 selects the shutdown mode for the negative output. Tables 1 and 2 list the selectable jumper options.

Current Limit

The 2-pin header JU2 selects the current limit for the positive output circuit, while JU3 selects the current limit for the negative output. Table 3 lists the selectable jumper options. The MAX686 EV kit comes configured for a 500mA current limit.

**Table 1. Jumper JU1 Functions
(Positive Output)**

SHUNT LOCATION	$\overline{\text{SHDN}}$ PIN	MAX686 OUTPUT
1 & 2	Connected to GND	Shutdown mode $V_{\text{OUT}} = V_{\text{BATT}} - V_{\text{DIODE}}$
2 & 3	Connected to VIN	MAX686 enabled, $V_{\text{OUT}} = +18\text{V}$

**Table 2. Jumper JU4 Functions
(Negative Output)**

SHUNT LOCATION	$\overline{\text{SHDN}}$ PIN	MAX686 OUTPUT
1 & 2	Connected to GND	Shutdown mode, $V_{\text{OUT}} = 0\text{V}$
2 & 3	Connected to VIN	MAX686 enabled, $V_{\text{OUT}} = -17\text{V}$

Table 3. Jumpers JU2 and JU3 Functions

SHUNT LOCATION	ISET PIN	CURRENT LIMIT (mA)
On	Connected to GND	250
Off	Connected to VIN	500

MAX686 Evaluation Kit

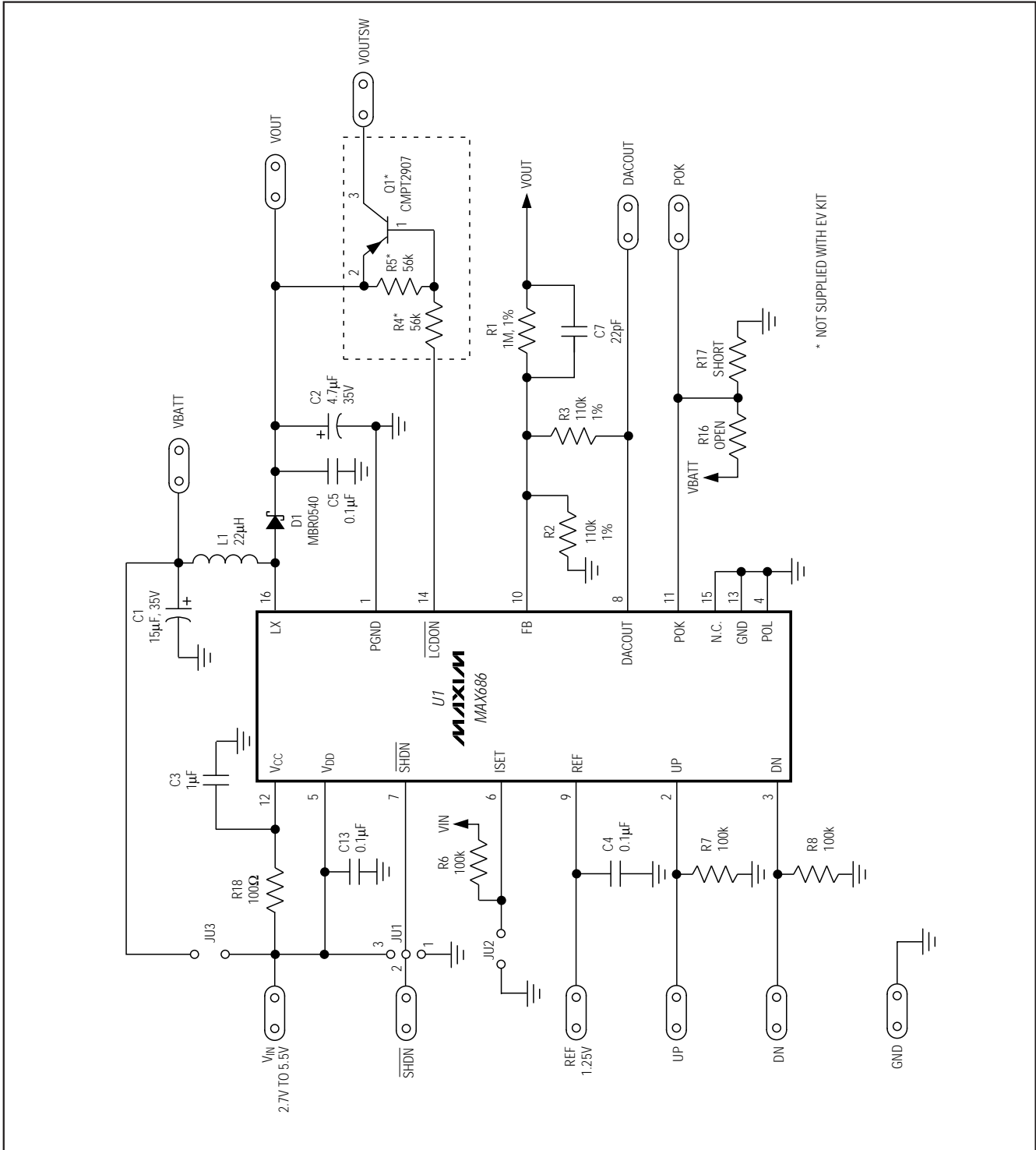

* NOT SUPPLIED WITH EV KIT

Figure 1a. MAX686 EV Kit Positive Output Schematic

MAX686 Evaluation Kit

Evaluates: MAX686

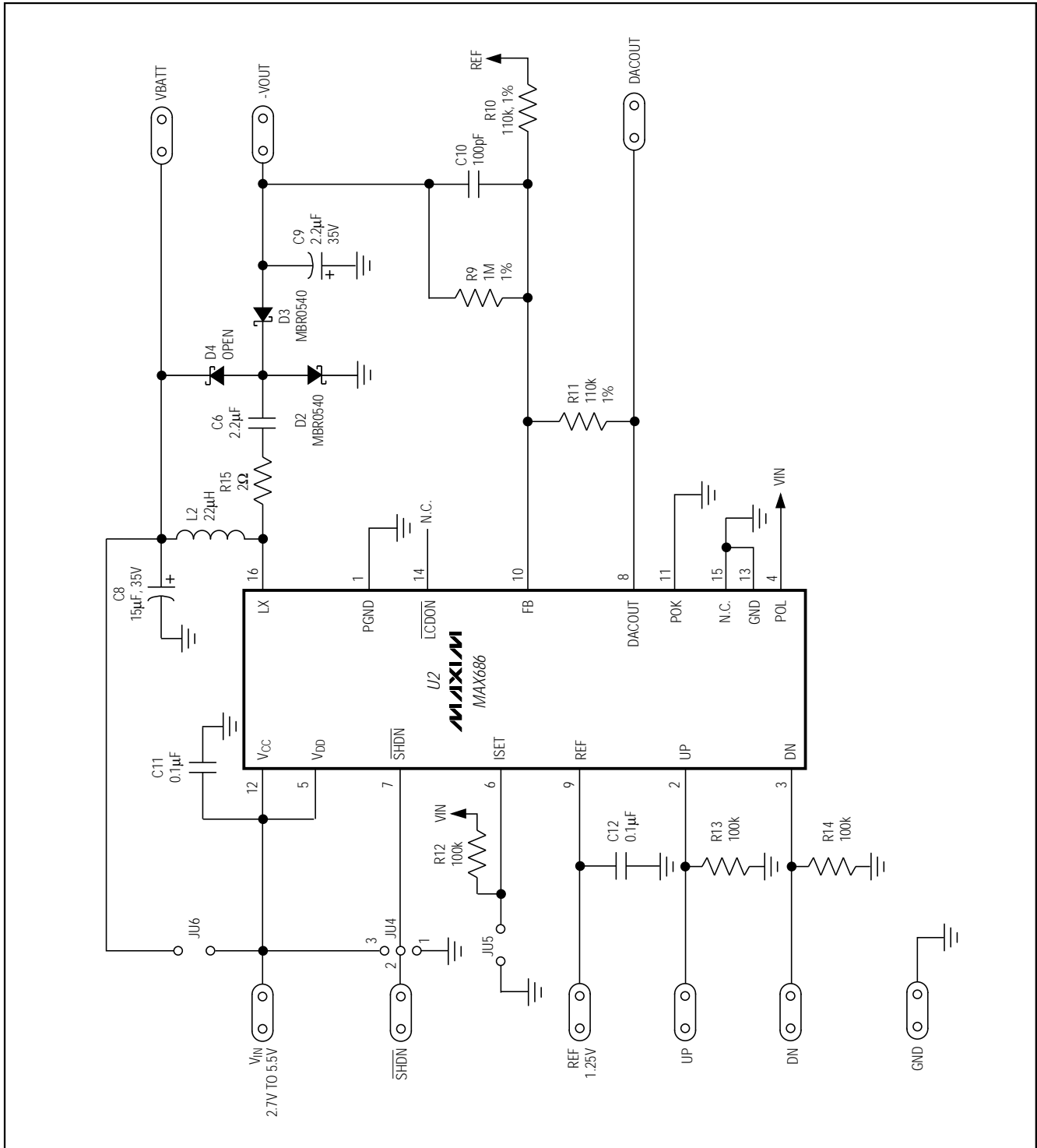

Figure 1b. MAX686 EV Kit Negative Output Schematic

MAX686 Evaluation Kit

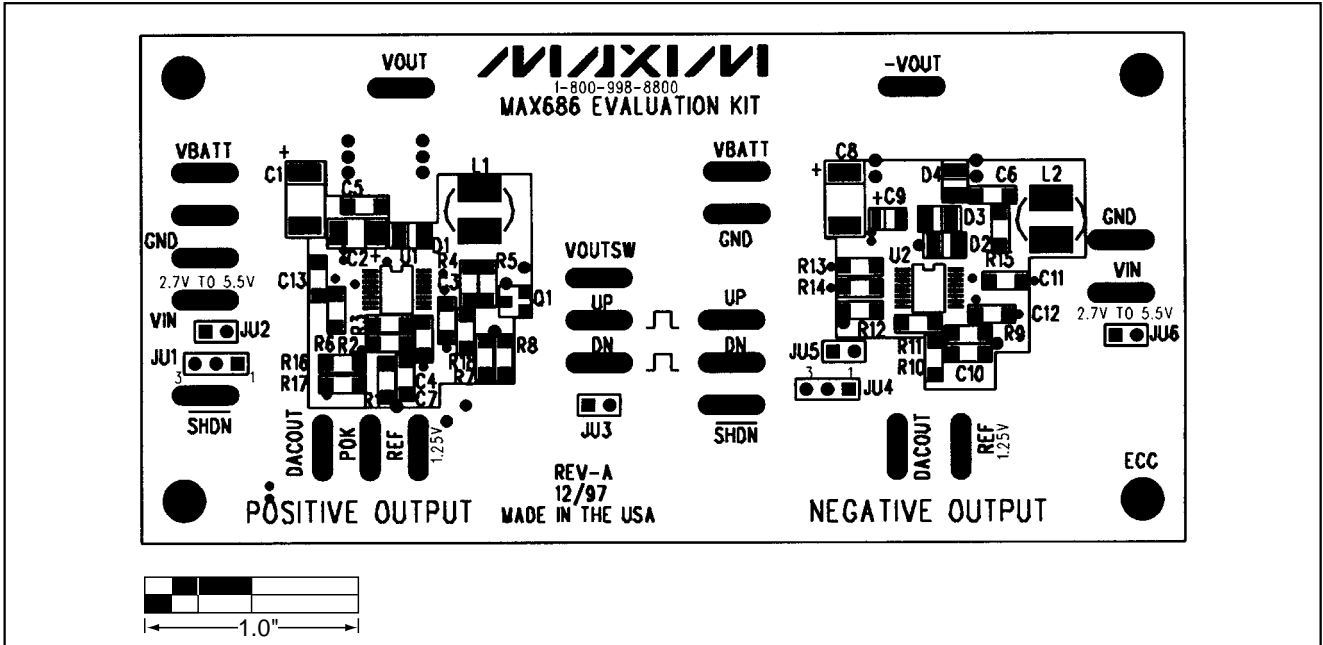

Figure 2. MAX686 EV Kit Component Placement Guide

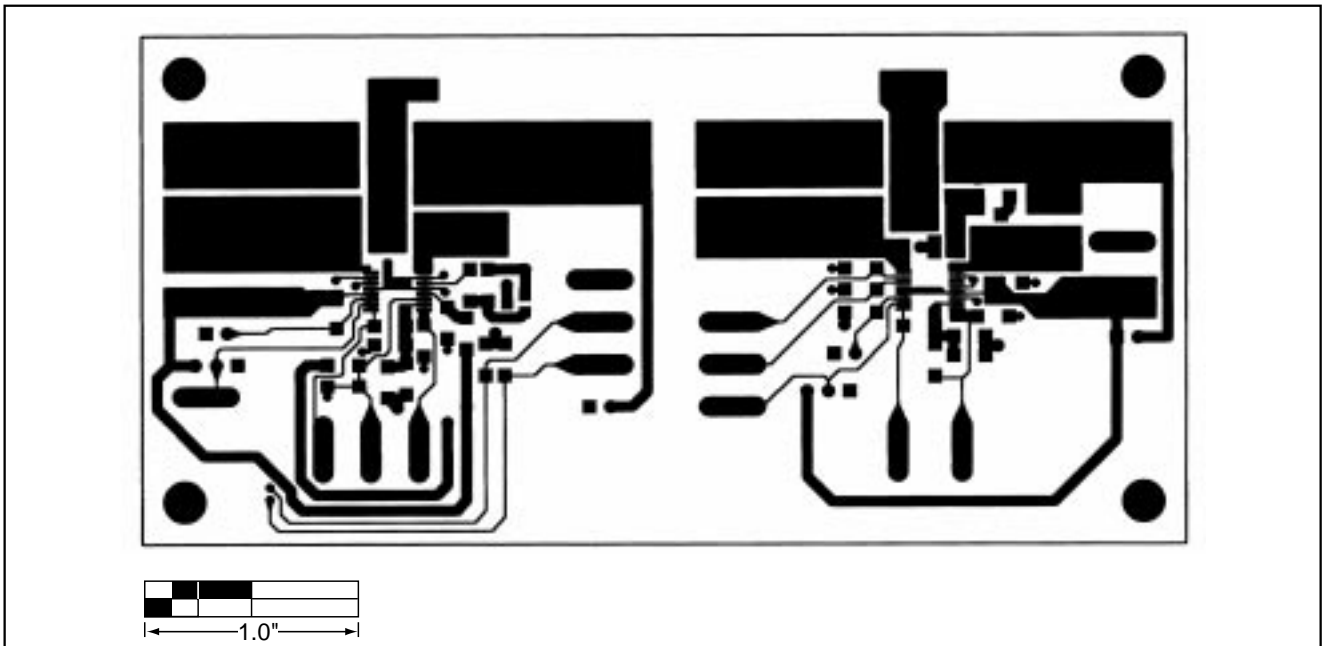

Figure 3. MAX686 EV Kit PC Board Layout—Component Side

MAX686 Evaluation Kit

Evaluates: MAX686

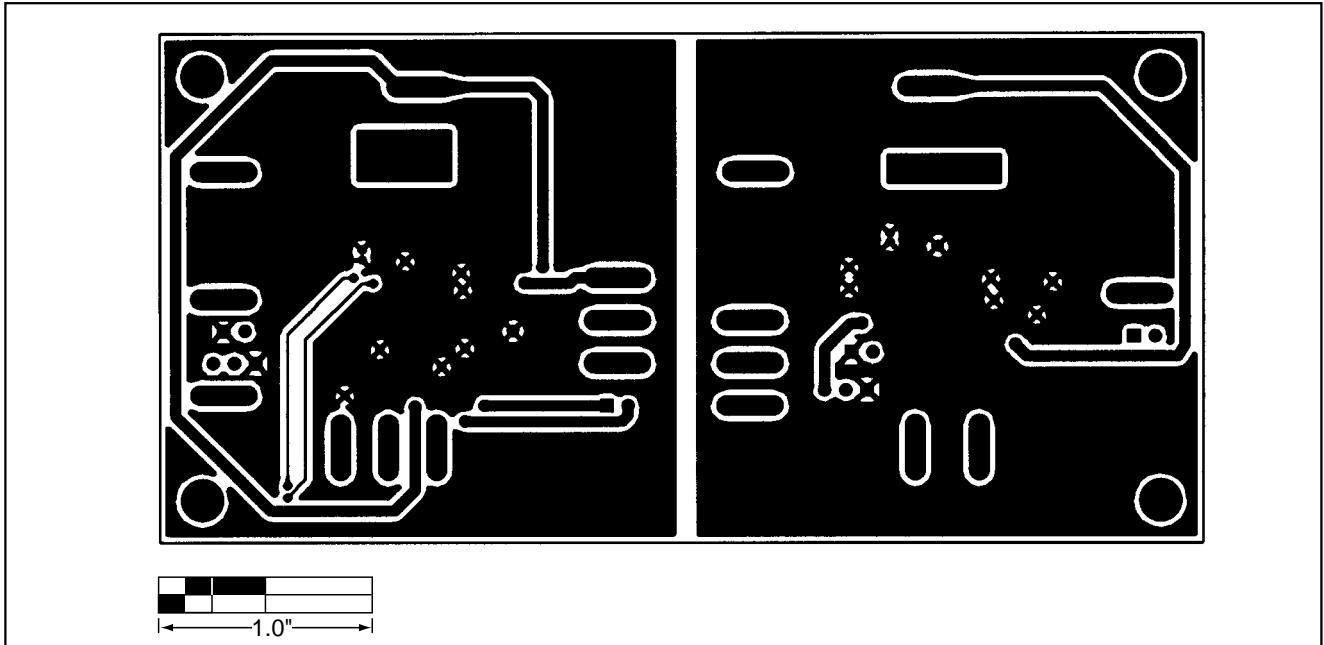

Figure 4. MAX686 EV Kit PC Board Layout—Solder Side

MAX686 Evaluation Kit

Evaluates: MAX686

NOTES

Maxim cannot assume responsibility for use of any circuitry other than circuitry entirely embodied in a Maxim product. No circuit patent licenses are implied. Maxim reserves the right to change the circuitry and specifications without notice at any time.

8 _____ Maxim Integrated Products, 120 San Gabriel Drive, Sunnyvale, CA 94086 408-737-7600

© 1998 Maxim Integrated Products

Printed USA

MAXIM is a registered trademark of Maxim Integrated Products.



Компания «ЭлектроПласт» предлагает заключение долгосрочных отношений при поставках импортных электронных компонентов на взаимовыгодных условиях!

Наши преимущества:

- Оперативные поставки широкого спектра электронных компонентов отечественного и импортного производства напрямую от производителей и с крупнейших мировых складов;
- Поставка более 17-ти миллионов наименований электронных компонентов;
- Поставка сложных, дефицитных, либо снятых с производства позиций;
- Оперативные сроки поставки под заказ (от 5 рабочих дней);
- Экспресс доставка в любую точку России;
- Техническая поддержка проекта, помощь в подборе аналогов, поставка прототипов;
- Система менеджмента качества сертифицирована по Международному стандарту ISO 9001;
- Лицензия ФСБ на осуществление работ с использованием сведений, составляющих государственную тайну;
- Поставка специализированных компонентов (Xilinx, Altera, Analog Devices, Intersil, Interpoint, Microsemi, Aeroflex, Peregrine, Syfer, Eurofarad, Texas Instrument, Miteq, Cobham, E2V, MA-COM, Hittite, Mini-Circuits, General Dynamics и др.);

Помимо этого, одним из направлений компании «ЭлектроПласт» является направление «Источники питания». Мы предлагаем Вам помощь Конструкторского отдела:

- Подбор оптимального решения, техническое обоснование при выборе компонента;
- Подбор аналогов;
- Консультации по применению компонента;
- Поставка образцов и прототипов;
- Техническая поддержка проекта;
- Защита от снятия компонента с производства.



Как с нами связаться

Телефон: 8 (812) 309 58 32 (многоканальный)

Факс: 8 (812) 320-02-42

Электронная почта: org@eplast1.ru

Адрес: 198099, г. Санкт-Петербург, ул. Калинина, дом 2, корпус 4, литера А.