

ELCO EUROPE (A DIVISION OF AVX LTD.) CONFIDENTIAL PROPRIETARY
 THE DRAWING ON THIS PRINT AND INFORMATION THEREWITH ARE
 PROPRIETARY TO ELCO EUROPE (A DIVISION OF AVX LTD.) AND
 SHALL NOT BE USED OR DISCUSSED IN WHOLE OR IN PART
 WITHOUT ELCO EUROPE'S WRITTEN CONSENT.

00-9276-00X-021-X06



PREFIX _____

CODE	TYPE
00	WIRE TO BOARD CONNECTOR

SERIES _____

NO. OF WAYS _____

CODE	NO. OF WAYS	DETAILS
001	1	SHEET 2
002	2	SHEET 3
003	3	SHEET 4
004	4	SHEET 5
006	6	SHEET 6
008	8	SHEET 7

STYLE _____

CODE	CONNECTOR STYLE
0	HORIZONTAL MOUNTING

WIRE SIZE _____

CODE	WIRE GAUGE	MAX CONDUCTOR	MAX INSULATION
21	18 TO 24 AWG	1.20mm DIAMETER	2.10mm DIAMETER

INSULATOR COLOUR _____

CODE	COLOUR	AVAILABILITY
0	BLACK	SPECIAL ORDER
1	WHITE	STANDARD

PLATING OPTION _____

CODE	CONTACT
06	TIN ALL OVER

FORM-106-01-056-6 ISS 7

Release No.
History
102631

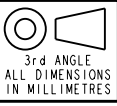

Drawn N.C.H.	Description 18-24 AWG WIRE TO BOARD CONNECTOR	DATE 01-Oct-09
Size CV	Part Number 00-9276-01_00S	Issue E

1 WAY WIRE TO BOARD CONNECTOR

ELCO EUROPE (A DIVISION OF AVX LTD.) CONFIDENTIAL PROPRIETARY
 THE DRAWING ON THIS PRINT AND INFORMATION THEREWITH ARE
 PROPRIETARY TO ELCO EUROPE (A DIVISION OF AVX LTD.) AND
 SHALL NOT BE USED OR DISCUSSED IN WHOLE OR IN PART
 WITHOUT ELCO EUROPE'S WRITTEN CONSENT.

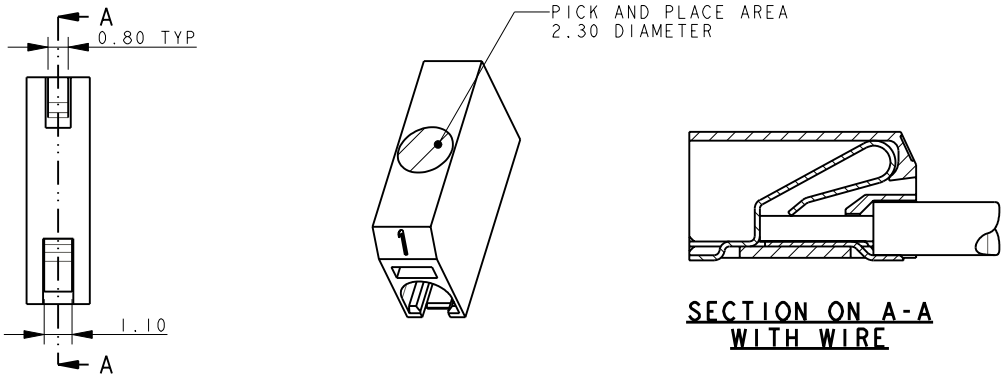
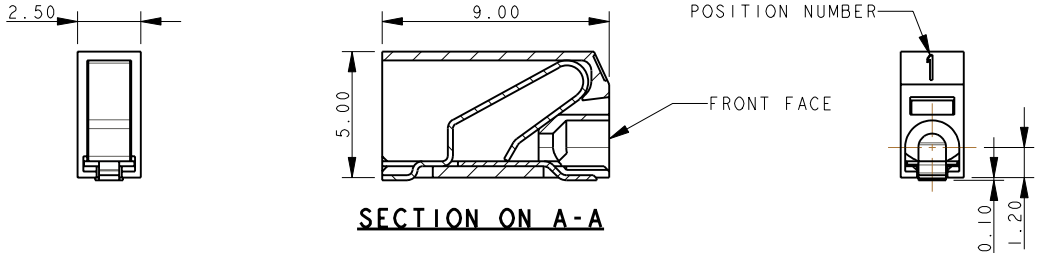

- NOTES :-
1. 9276 ONE WAY CONNECTOR, REFER TO ELCO SPECIFICATION 201-01-125 FOR FURTHER DETAILS.
 2. INSULATION MATERIAL :- NYLON 46, GLASS FILLED, UL94 V-0, COLOUR REFER TO SHEET 1.
 3. CONTACT MATERIAL :- COPPER ALLOY, 0.20mm THICK, TIN PLATED.
 4. OUTLINE OF CONNECTOR.
 5. WIRE ASSEMBLY/EXTRACTION, REFER TO SHEET 8.
 6. FRONT FACE OF CONNECTOR CAN BE IN LINE WITH EDGE OF PCB.
 7. PACKING IN TAPE AND REEL, QUANTITY 1000 PER REEL.

PACKING DETAILS

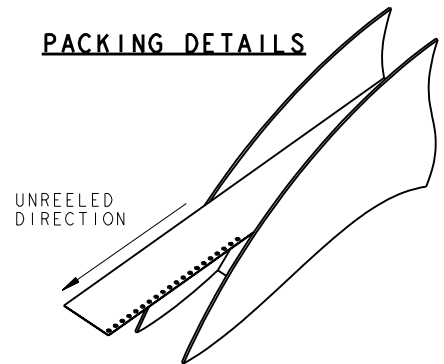

1 WAY PCB BOARD LAYOUT

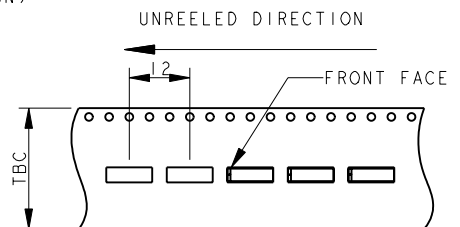
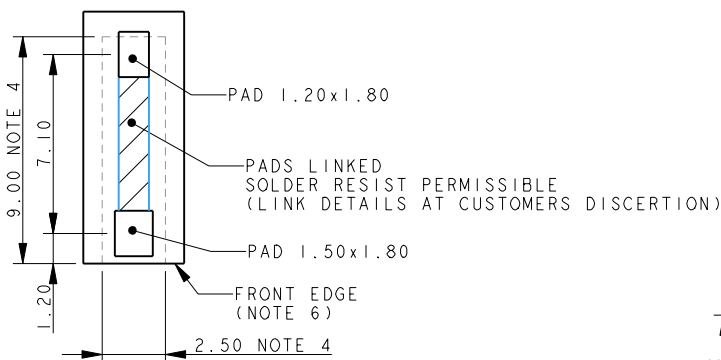

ELCO EUROPE (A DIVISION OF AVX LTD.) CONFIDENTIAL PROPRIETARY
 THE DRAWING ON THIS PRINT AND INFORMATION THEREWITH ARE
 PROPRIETARY TO ELCO EUROPE (A DIVISION OF AVX LTD.) AND
 SHALL NOT BE USED OR DISCLOSED IN WHOLE OR IN PART
 WITHOUT ELCO EUROPE'S WRITTEN CONSENT.

SHEET 2 OF 8

Release No.
History
102631

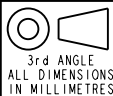

© COPYRIGHT ELCO EUROPE
 NOT TO BE DISCLOSED OR COPIED
 WITHOUT WRITTEN PERMISSION

Drawn
N.C.H.

Description
18-24 AWG WIRE TO BOARD CONNECTOR

DATE
13-Nov-09

Size
CV

Part Number
00-9276-01_000S

Issue
E

A

B

2 WAY WIRE TO BOARD CONNECTOR

ELCO EUROPE (A DIVISION OF AVX LTD.) CONFIDENTIAL PROPRIETARY
 THE DRAWING ON THIS PRINT AND INFORMATION THEREWITH ARE
 PROPRIETARY TO ELCO EUROPE (A DIVISION OF AVX LTD.) AND
 SHALL NOT BE USED OR DISCUSSED IN WHOLE OR IN PART
 WITHOUT ELCO EUROPE'S WRITTEN CONSENT.

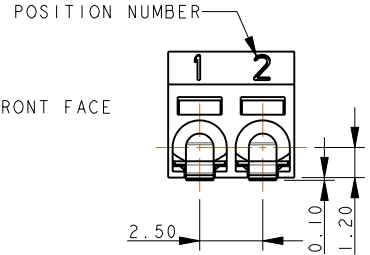
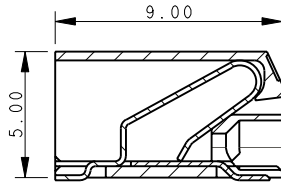
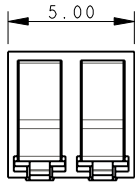

SECTION ON A-A

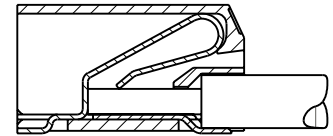
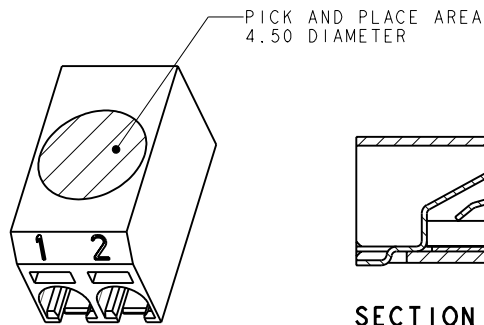
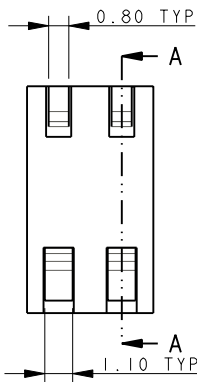

**SECTION ON A-A
WITH WIRE**

NOTES :-

1. 9276 TWO WAY CONNECTOR, REFER TO ELCO SPECIFICATION 201-01-125 FOR FURTHER DETAILS.
2. INSULATION MATERIAL :- NYLON 46, GLASS FILLED, UL94 V-0, COLOUR REFER TO SHEET 1.
3. CONTACT MATERIAL :- COPPER ALLOY, 0.20mm THICK, TIN PLATED.
4. OUTLINE OF CONNECTOR.
5. WIRE ASSEMBLY/EXTRACTION, REFER TO SHEET 8.
6. FRONT FACE OF CONNECTOR CAN BE IN LINE WITH EDGE OF PCB.
7. PACKING IN TAPE AND REEL, QUANTITY 1000 PER REEL.

2 WAY PCB BOARD LAYOUT

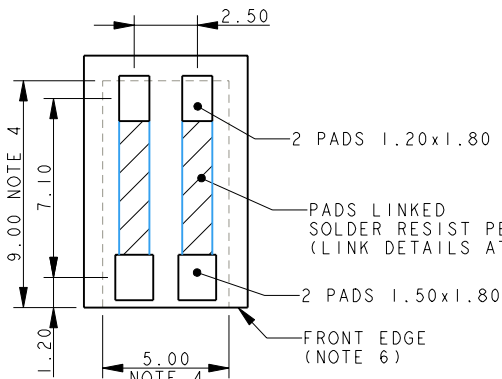

PACKING DETAILS

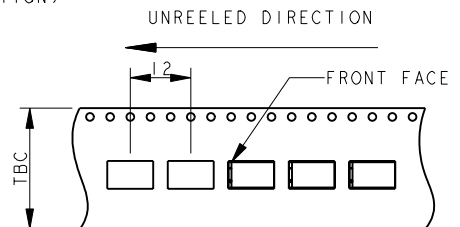
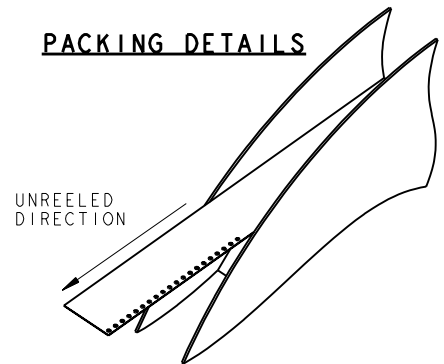

ELCO EUROPE (A DIVISION OF AVX LTD.) CONFIDENTIAL PROPRIETARY
 THE DRAWING ON THIS PRINT AND INFORMATION THEREWITH ARE
 PROPRIETARY TO ELCO EUROPE (A DIVISION OF AVX LTD.) AND
 SHALL NOT BE USED OR DISCLOSED IN WHOLE OR IN PART
 WITHOUT ELCO EUROPE'S WRITTEN CONSENT.

SHEET 3 OF 8

Release No.
History
102631

3rd ANGLE
ALL DIMENSIONS
IN MILLIMETRES

ELCO

© COPYRIGHT ELCO EUROPE
 NOT TO BE DISCLOSED OR COPIED
 WITHOUT WRITTEN PERMISSION

Drawn
N.C.H.

Size
CV

Description
18-24 AWG WIRE TO BOARD CONNECTOR

Part Number
00-9276-01_000S

DATE
13-Nov-09

Issue
E

A

B

3 WAY WIRE TO BOARD CONNECTOR

ELCO EUROPE (A DIVISION OF AVX LTD.) CONFIDENTIAL PROPRIETARY
 THE DRAWING ON THIS PRINT AND INFORMATION THEREWITH ARE
 PROPRIETARY TO ELCO EUROPE (A DIVISION OF AVX LTD.) AND
 SHALL NOT BE USED OR DISCUSSED IN WHOLE OR IN PART
 WITHOUT ELCO EUROPE'S WRITTEN CONSENT.

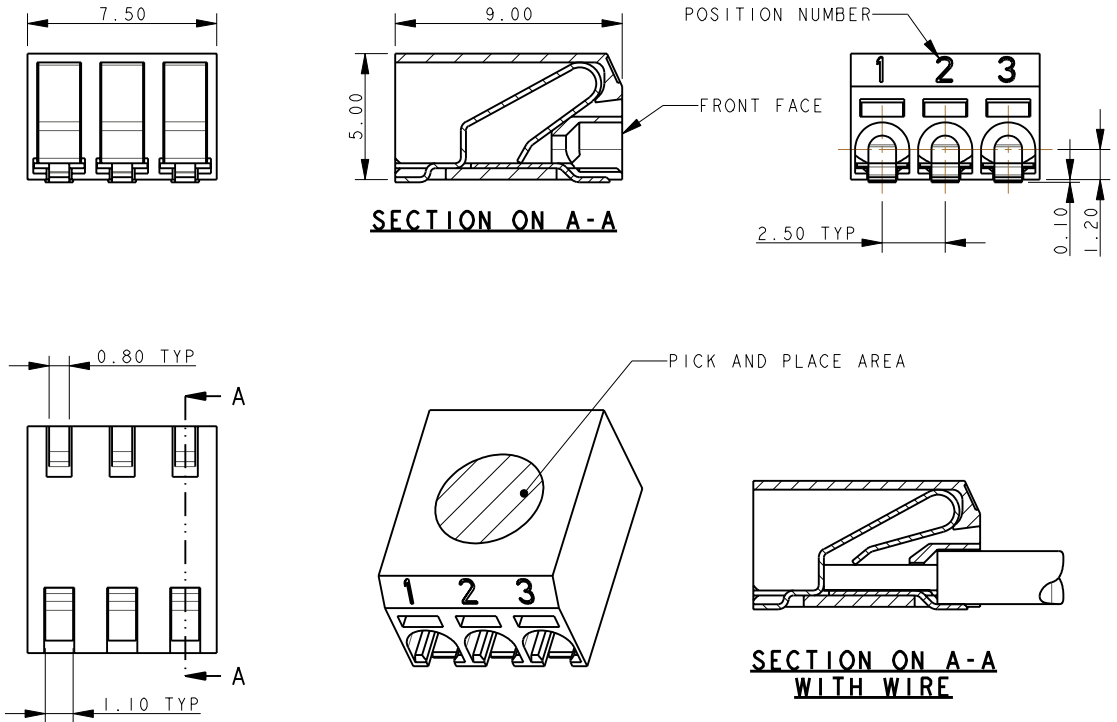

NOTES :-

1. 9276 THREE WAY CONNECTOR, REFER TO ELCO SPECIFICATION 201-01-125 FOR FURTHER DETAILS.
2. INSULATION MATERIAL :- NYLON 46, GLASS FILLED, UL94 V-0, COLOUR REFER TO SHEET 1.
3. CONTACT MATERIAL :- COPPER ALLOY, 0.20mm THICK, TIN PLATED.
4. OUTLINE OF CONNECTOR.
5. WIRE ASSEMBLY/EXTRACTION, REFER TO SHEET 8.
6. FRONT FACE OF CONNECTOR CAN BE IN LINE WITH EDGE OF PCB.
7. PACKING IN TAPE AND REEL, QUANTITY 1000 PER REEL.

3 WAY PCB BOARD LAYOUT

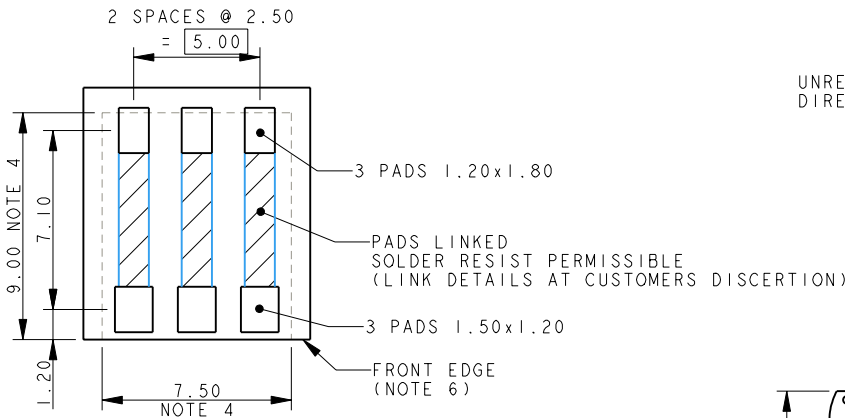

PACKING DETAILS

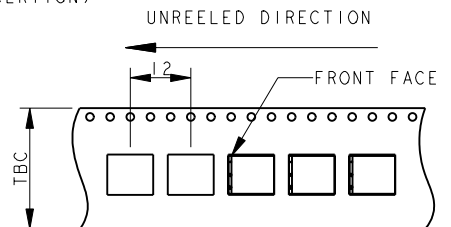
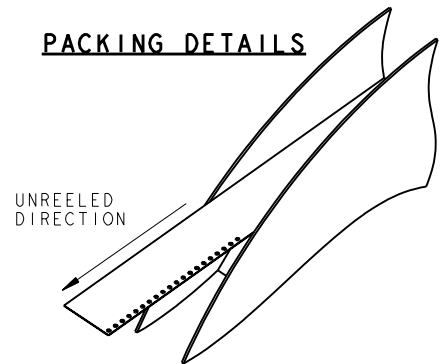

ELCO EUROPE (A DIVISION OF AVX LTD.) CONFIDENTIAL PROPRIETARY
 THE DRAWING ON THIS PRINT AND INFORMATION THEREWITH ARE
 PROPRIETARY TO ELCO EUROPE (A DIVISION OF AVX LTD.) AND
 SHALL NOT BE USED OR DISCUSSED IN WHOLE OR IN PART
 WITHOUT ELCO EUROPE'S WRITTEN CONSENT.

SHEET 4 OF 8

Release No.
 History
 102631

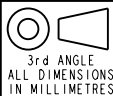

ELCO

© COPYRIGHT ELCO EUROPE
 NOT TO BE DISCLOSED OR COPIED
 WITHOUT WRITTEN PERMISSION

Drawn
 N.C.H.

Size
 CV

Description
 18-24 AWG WIRE TO BOARD CONNECTOR

Part Number
 00-9276-01_000S

DATE
 13-Nov-09

Issue
 E

4 WAY WIRE TO BOARD CONNECTOR

ELCO EUROPE (A DIVISION OF AVX LTD.) CONFIDENTIAL PROPRIETARY
 THE DRAWING ON THIS PRINT AND INFORMATION THEREWITH ARE
 PROPRIETARY TO ELCO EUROPE (A DIVISION OF AVX LTD.) AND
 SHALL NOT BE USED OR DISCUSSED IN WHOLE OR IN PART
 WITHOUT ELCO EUROPE'S WRITTEN CONSENT.

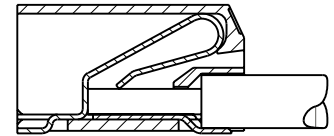
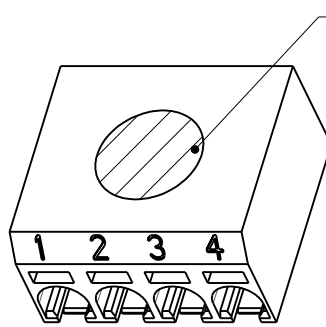
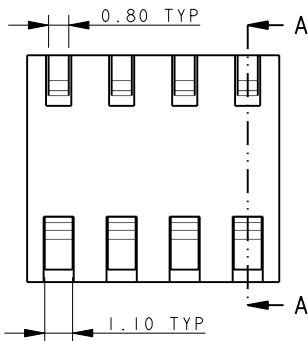
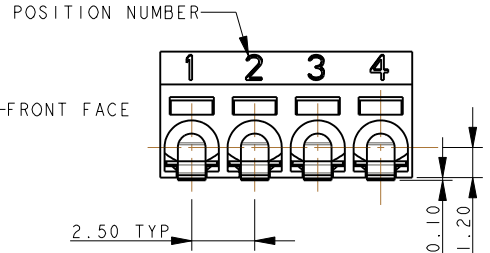
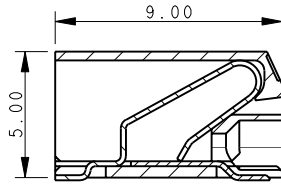
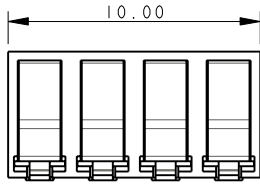

SECTION ON A-A WITH WIRE

- NOTES :-
1. 9276 FOUR WAY CONNECTOR, REFER TO ELCO SPECIFICATION 201-01-125 FOR FURTHER DETAILS.
 2. INSULATION MATERIAL :- NYLON 46, GLASS FILLED, UL94 V-0, COLOUR REFER TO SHEET 1.
 3. CONTACT MATERIAL :- COPPER ALLOY, 0.20mm THICK, TIN PLATED.
 4. OUTLINE OF CONNECTOR.
 5. WIRE ASSEMBLY/EXTRACTION, REFER TO SHEET 8.
 6. FRONT FACE OF CONNECTOR CAN BE IN LINE WITH EDGE OF PCB.
 7. PACKING IN TAPE AND REEL, QUANTITY 1000 PER REEL.

4 WAY PCB BOARD LAYOUT

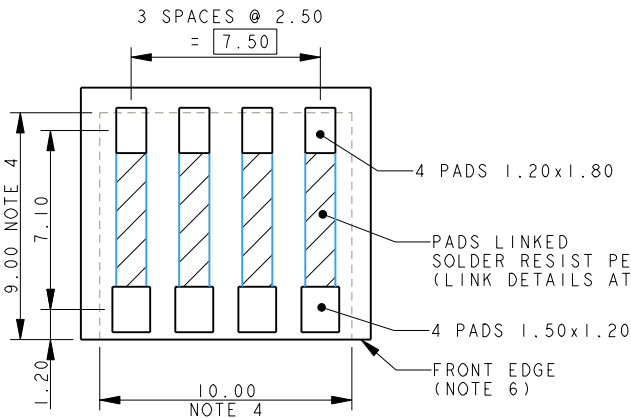

PACKING DETAILS

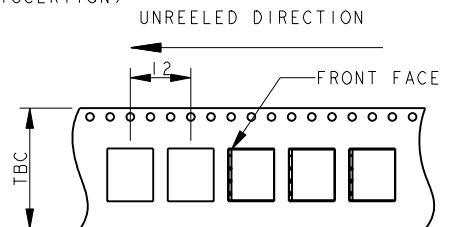
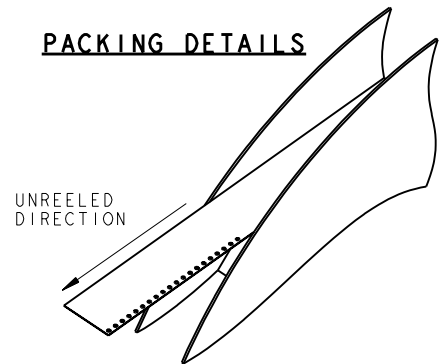

ELCO EUROPE (A DIVISION OF AVX LTD.) CONFIDENTIAL PROPRIETARY
 THE DRAWING ON THIS PRINT AND INFORMATION THEREWITH ARE
 PROPRIETARY TO ELCO EUROPE (A DIVISION OF AVX LTD.) AND
 SHALL NOT BE USED OR DISCUSSED IN WHOLE OR IN PART
 WITHOUT ELCO EUROPE'S WRITTEN CONSENT.

SHEET 5 OF 8

Release No.
 History
 102631

3rd ANGLE
 ALL DIMENSIONS
 IN MILLIMETRES

ELCO
 © COPYRIGHT ELCO EUROPE
 NOT TO BE DISCLOSED OR COPIED
 WITHOUT WRITTEN PERMISSION

Drawn
 N.C.H.
 Size
 CV

Description
 18-24 AWG WIRE TO BOARD CONNECTOR
 Part Number
 00-9276-01_000S

DATE
 13-Nov-09
 Issue
 E

6 WAY WIRE TO BOARD CONNECTOR

ELCO EUROPE (A DIVISION OF AVX LTD.) CONFIDENTIAL PROPRIETARY
 THE DRAWING ON THIS PRINT AND INFORMATION THEREWITH ARE
 PROPRIETARY TO ELCO EUROPE (A DIVISION OF AVX LTD.) AND
 SHALL NOT BE USED OR DISCUSSED IN WHOLE OR IN PART
 WITHOUT ELCO EUROPE'S WRITTEN CONSENT.

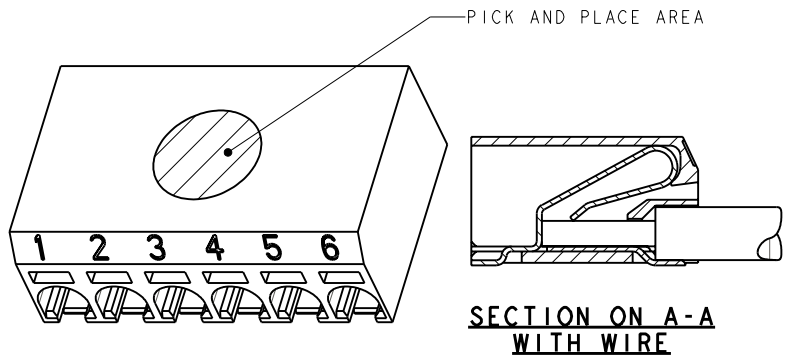
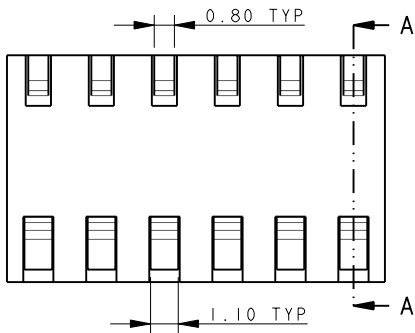
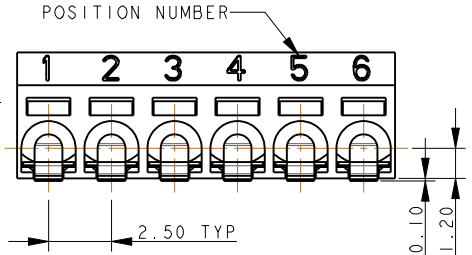
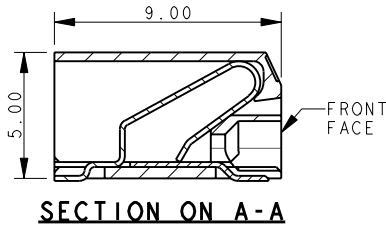
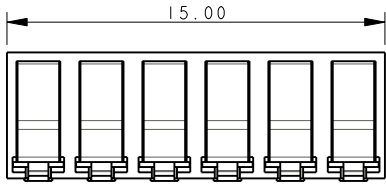

- NOTES :-
- 9276 SIX WAY CONNECTOR, REFER TO ELCO SPECIFICATION 201-01-125 FOR FURTHER DETAILS.
 - INSULATION MATERIAL :- NYLON 46, GLASS FILLED, UL94 V-0, COLOUR REFER TO SHEET 1.
 - CONTACT MATERIAL :- COPPER ALLOY, 0.20mm THICK, TIN PLATED.
 - OUTLINE OF CONNECTOR.
 - WIRE ASSEMBLY/EXTRACTION, REFER TO SHEET 8.
 - FRONT FACE OF CONNECTOR CAN BE IN LINE WITH EDGE OF PCB.
 - PACKING IN TAPE AND REEL, QUANTITY 1000 PER REEL.

6 WAY PCB BOARD LAYOUT

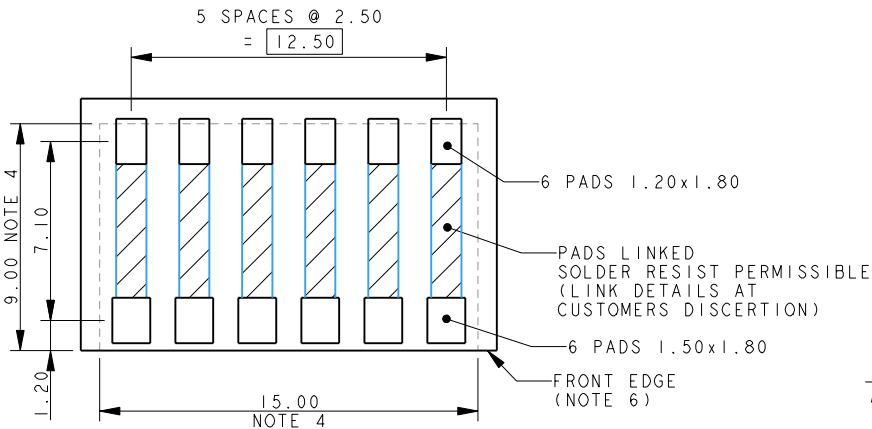

PACKING DETAILS

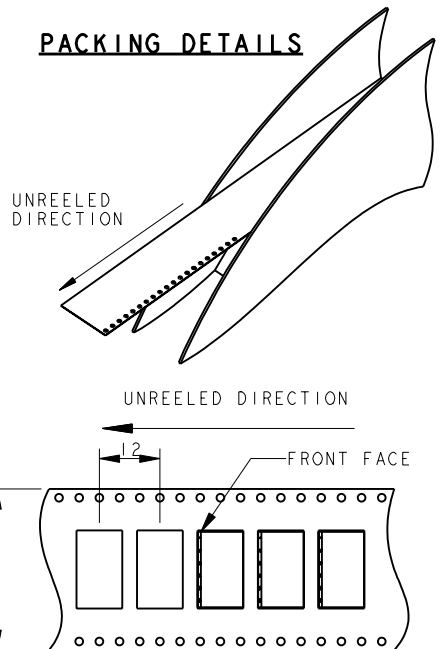

ELCO EUROPE (A DIVISION OF AVX LTD.) CONFIDENTIAL PROPRIETARY
 THE DRAWING ON THIS PRINT AND INFORMATION THEREWITH ARE
 PROPRIETARY TO ELCO EUROPE (A DIVISION OF AVX LTD.) AND
 SHALL NOT BE USED OR DISCLOSED IN WHOLE OR IN PART
 WITHOUT ELCO EUROPE'S WRITTEN CONSENT.

SHEET 6 OF 8

Release No.
History
102631

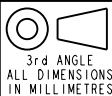

ELCO

© COPYRIGHT ELCO EUROPE
 NOT TO BE DISCLOSED OR COPIED
 WITHOUT WRITTEN PERMISSION

Drawn
N.C.H.
Size
CV

Description
18-24 AWG WIRE TO BOARD CONNECTOR
Part Number
00-9276-01_000S

DATE
13-Nov-09
Issue
E

8 WAY WIRE TO BOARD CONNECTOR

ELCO EUROPE (A DIVISION OF AVX LTD.) CONFIDENTIAL PROPRIETARY
 THE DRAWING ON THIS PRINT AND INFORMATION THEREWITH ARE
 PROPRIETARY TO ELCO EUROPE (A DIVISION OF AVX LTD.) AND
 SHALL NOT BE USED OR DISCUSSED IN WHOLE OR IN PART
 WITHOUT ELCO EUROPE'S WRITTEN CONSENT.

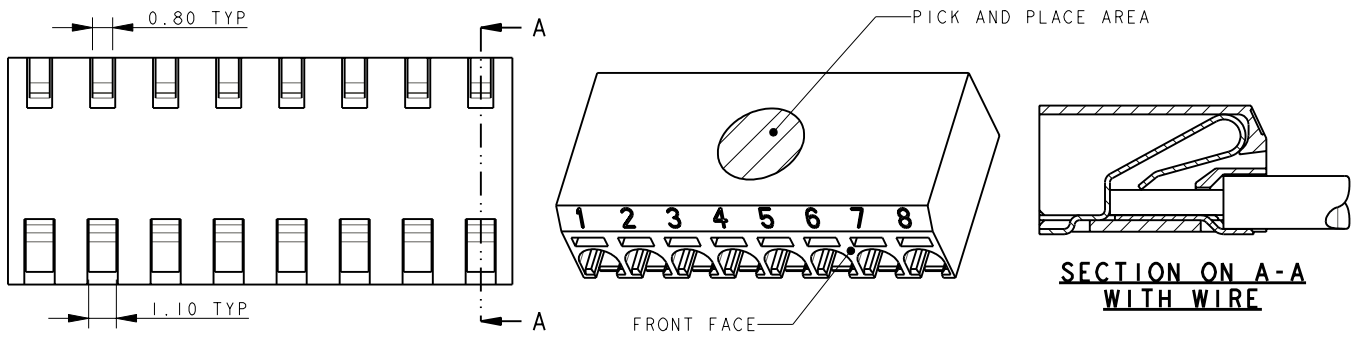
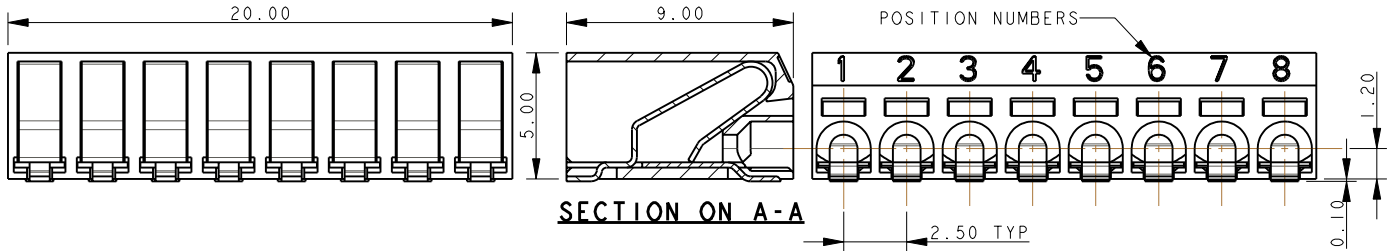

NOTES :-

1. 9276 EIGHT WAY CONNECTOR, REFER TO ELCO SPECIFICATION 201-01-125 FOR FURTHER DETAILS.
2. INSULATION MATERIAL :- NYLON 46, GLASS FILLED, UL94 V-0, COLOUR REFER TO SHEET 1.
3. CONTACT MATERIAL :- COPPER ALLOY, 0.20mm THICK, TIN PLATED.
4. OUTLINE OF CONNECTOR.
5. WIRE ASSEMBLY/EXTRACTION, REFER TO SHEET 8.
6. FRONT FACE OF CONNECTOR CAN BE IN LINE WITH EDGE OF PCB.
7. PACKING IN TAPE AND REEL, QUANTITY 1000 PER REEL.

PACKING DETAILS

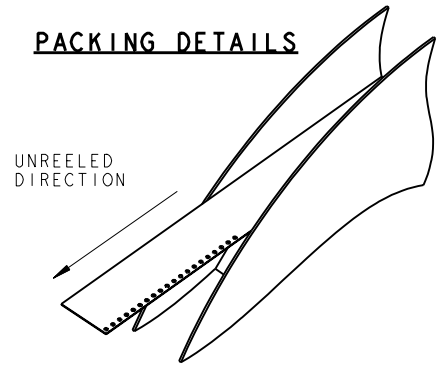

8 WAY PCB BOARD LAYOUT

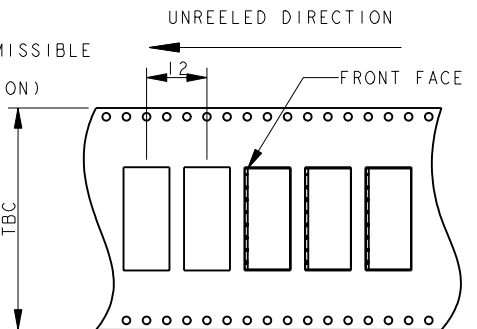
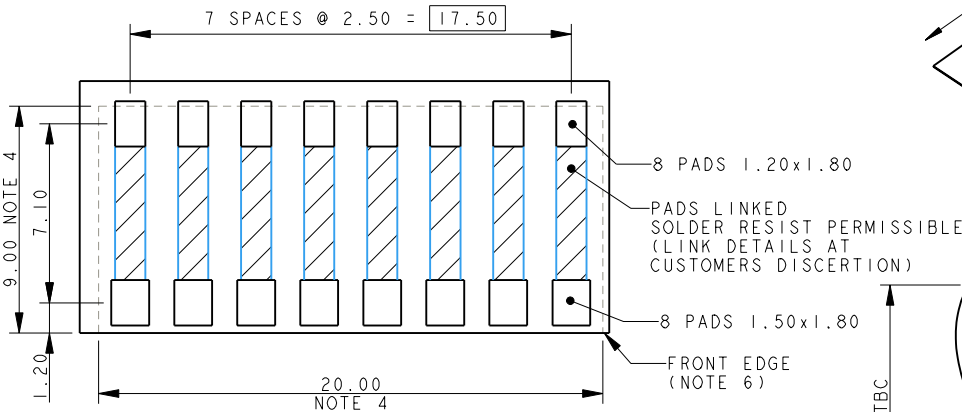

ELCO EUROPE (A DIVISION OF AVX LTD.) CONFIDENTIAL PROPRIETARY
 THE DRAWING ON THIS PRINT AND INFORMATION THEREWITH ARE
 PROPRIETARY TO ELCO EUROPE (A DIVISION OF AVX LTD.) AND
 SHALL NOT BE USED OR DISCUSSED IN WHOLE OR IN PART
 WITHOUT ELCO EUROPE'S WRITTEN CONSENT.

SHEET 7 OF 8

Release No.
 History
 102631

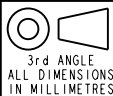

© COPYRIGHT ELCO EUROPE
 NOT TO BE DISCLOSED OR COPIED
 WITHOUT WRITTEN PERMISSION

Drawn
 N.C.H.
 Size
 CV

Description
 18-24 AWG WIRE TO BOARD CONNECTOR
 Part Number
 00-9276-01_000S

DATE
 13-Nov-09
 Issue
 E

WIRE ASSEMBLY

ELCO EUROPE (A DIVISION OF AVX LTD.) CONFIDENTIAL PROPRIETARY THE DRAWING ON THIS PRINT AND INFORMATION THEREWITH ARE PROPRIETARY TO ELCO EUROPE (A DIVISION OF AVX LTD.) AND SHALL NOT BE USED OR DISCUSSED IN WHOLE OR IN PART WITHOUT ELCO EUROPE'S WRITTEN CONSENT.

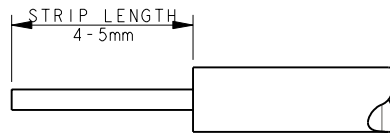

TRIM INSULATION.
DO NOT CRUSH CENTRE OF WIRE.
STRANDED WIRES TWISTED TOGETHER BEFORE INSETION.
CHECK ALL STRANDS OF WIRE ARE CORRECTLY ALIGNED AFTER THE INSULATION IS REMOVED.

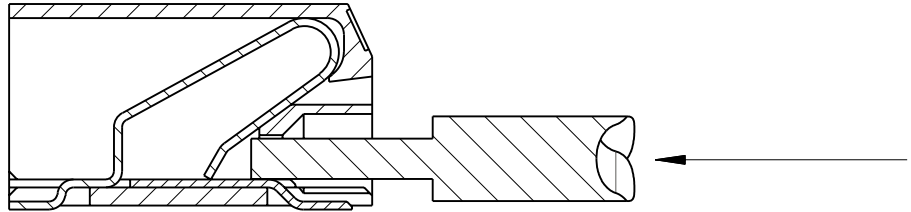

PUSH WIRE INTO HOLE IN FRONT OF CONNECTOR.
DO NOT BEND CONNECTOR.

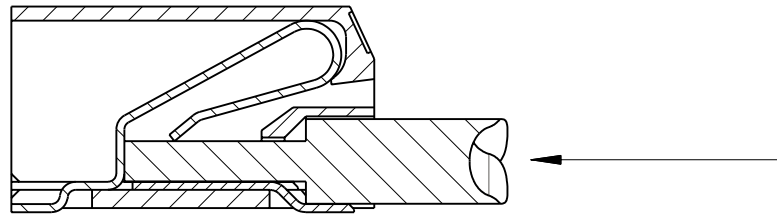

CONTINUE TO PUSH WIRE UNTIL STOP IS REACHED.

WIRE EXTRACTION

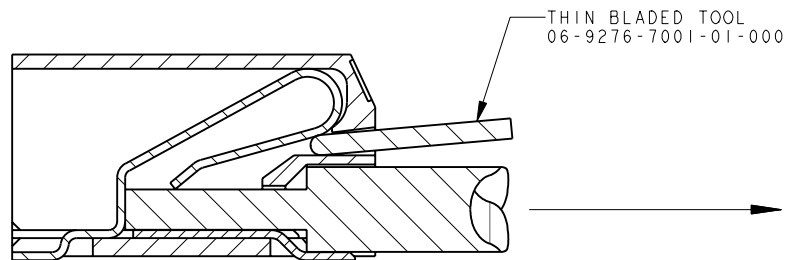

PUSH BLADE (NOT SHARP) INTO SLOT ABOVE WIRE.
WHEN WIRE IS FREE, PULL TO EXTRACT.

ELCO EUROPE (A DIVISION OF AVX LTD.) CONFIDENTIAL PROPRIETARY THE DRAWING ON THIS PRINT AND INFORMATION THEREWITH ARE PROPRIETARY TO ELCO EUROPE (A DIVISION OF AVX LTD.) AND SHALL NOT BE USED OR DISCLOSED IN WHOLE OR IN PART WITHOUT ELCO EUROPE'S WRITTEN CONSENT.

SHEET 8 OF 8

FORM-106-01-056-6 ISS 7
Release No.
History
102631

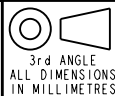

ELCO

© COPYRIGHT ELCO EUROPE
NOT TO BE DISCLOSED OR COPIED
WITHOUT WRITTEN PERMISSION

Drawn
N.C.H.

Size
CV

Description
18-24 AWG WIRE TO BOARD CONNECTOR

Part Number
00-9276-01_000S

DATE
13-Nov-09

Issue
E

A

I

B

Mouser Electronics

Authorized Distributor

Click to View Pricing, Inventory, Delivery & Lifecycle Information:

[AVX:](#)

[00-9276001021106](#) [00-9276002021106](#) [00-9276003021106](#) [00-9276004021106](#) [00-9276006021106](#) [00-9276008021106](#) [009276004021106](#) [009276002021106](#) [009276006021106](#) [009276002021006](#) [009276003021106](#) [009276008021106](#) [009276001021106](#) [009276001021006](#) [009276003021006](#) [009276004021006](#) [009276006021006](#) [009276008021006](#)



Компания «ЭлектроПласт» предлагает заключение долгосрочных отношений при поставках импортных электронных компонентов на взаимовыгодных условиях!

Наши преимущества:

- Оперативные поставки широкого спектра электронных компонентов отечественного и импортного производства напрямую от производителей и с крупнейших мировых складов;
- Поставка более 17-ти миллионов наименований электронных компонентов;
- Поставка сложных, дефицитных, либо снятых с производства позиций;
- Оперативные сроки поставки под заказ (от 5 рабочих дней);
- Экспресс доставка в любую точку России;
- Техническая поддержка проекта, помощь в подборе аналогов, поставка прототипов;
- Система менеджмента качества сертифицирована по Международному стандарту ISO 9001;
- Лицензия ФСБ на осуществление работ с использованием сведений, составляющих государственную тайну;
- Поставка специализированных компонентов (Xilinx, Altera, Analog Devices, Intersil, Interpoint, Microsemi, Aeroflex, Peregrine, Syfer, Eurofarad, Texas Instrument, Miteq, Cobham, E2V, MA-COM, Hittite, Mini-Circuits, General Dynamics и др.);

Помимо этого, одним из направлений компании «ЭлектроПласт» является направление «Источники питания». Мы предлагаем Вам помощь Конструкторского отдела:

- Подбор оптимального решения, техническое обоснование при выборе компонента;
- Подбор аналогов;
- Консультации по применению компонента;
- Поставка образцов и прототипов;
- Техническая поддержка проекта;
- Защита от снятия компонента с производства.



Как с нами связаться

Телефон: 8 (812) 309 58 32 (многоканальный)

Факс: 8 (812) 320-02-42

Электронная почта: org@eplast1.ru

Адрес: 198099, г. Санкт-Петербург, ул. Калинина, дом 2, корпус 4, литера А.