

MAXIM

MAX3170 Evaluation Kit

General Description

The MAX3170 evaluation kit (EV kit) combines Maxim's multiprotocol clock/data transceiver (MAX3170), control transceiver (MAX3171), and cable terminator (MAX3172) chips. This chipset forms a complete software-selectable data terminal equipment (DTE) or data communications equipment (DCE) interface port.

The MAX3170, MAX3171, and MAX3172 chipset supports V.28 (RS-232), V.11 (RS-449/V.36, EIA-530, EIA-530A, X.21), and V.35 protocols. Compliance for NET1, NET2, TBR-1, and TBR-2 has been certified by TUV Telecom Services, Inc. Internal charge pumps allow this kit to operate from a single +3.3V supply.

The MAX3170 EV kit was designed to take advantage of the chipset's flow-through pinout. This kit includes a 40-pin header (logic signals), a female DB25 connector (protocol signals), three SMA connectors (high-speed logic signals), and scope probe connectors for measuring the high-speed data signals (logic and protocol signals).

Features

- ◆ Industry's First Single +3.3V Supply Multiprotocol Chipset
- ◆ Industry's First Multiprotocol Chipset with True Failsafe Receivers
- ◆ Programmable Transceiver Supports
 - V.28 (RS-232)
 - V.11 (RS-449/V.36, EIA-530, EIA-530A, X.21)
 - V.35
- ◆ Certified TBR-1 and TBR-2 Compliant
- ◆ Certified NET1 and NET2 Compliant
- ◆ Programmable Cable Termination (MAX3172)
- ◆ Receiver Control Line Deglitching
- ◆ Fully Assembled and Tested

Ordering Information

PART	TEMP. RANGE
MAX3170EVKIT	0°C to +70°C

Component List

DESIGNATION	QTY	DESCRIPTION
C1, C2, C5, C6, C7, C10	6	3.3μF, 10V X7R ceramic capacitors (1206) Taiyo Yuden LMK316BJ335ML
C3, C4, C8, C9	4	1.0μF, X5R ceramic capacitors (0805) Taiyo Yuden LMK212BJ105MG
C11, C12, C13	3	100pF ceramic capacitors (0805)
C14, C15, C17	3	0.1μF ceramic capacitors (0805)
C16	1	47μF, 6.3V tantalum capacitor AVX TAJD476M006
D1, D2, D3, D5, D6, D9	6	Red LEDs
D4, D7, D8, D10, D11, D12	6	Green LEDs

DESIGNATION	QTY	DESCRIPTION
D13–D16	4	Yellow LEDs
JU1–JU7, JU12	8	3-pin headers
JU8–JU11, JU14–JU17, JU19	9	2-pin headers
None	17	Shunts
J1	1	40-pin header (2×20) 0.1in center
J2	1	DB25 right-angle female connector AMP 747846-4
J3, J4, J5	3	SMA connectors (PC edge mount) EFJohnson 142-0701-801
R1, R2, R3	3	49.9Ω ±1% resistors (0805)
R8–R23	16	100Ω ±5% resistors (0805)



MAX3170 Evaluation Kit

Component List (continued)

DESIGNATION	QTY	DESCRIPTION
RXD/TXD, RXC/SCTE, TXC/N/A, N/A/TXC, SCTE/RXC, TXD/RXD, RXDA/TXDA, RXDB/TXDB, RXCA/SCTEA, RXCB/SCTEB, TXCA/TXCA, TXCB/TXCB, SCTEA/RXCA, SCTEB/RXCB, TXDA/RXDA, TXDB/RXDB	16	Scope probe connectors (top mount) Specialty Conn 33JR135-1
U1	1	MAX3170CAI (clock/data transceiver) (28 SSOP)
U2	1	MAX3171CAI (control transceiver) (28 SSOP)
U3	1	MAX3172CAI (terminator) (28 SSOP)
U4, U5	2	74HC240 (LED inverting drivers)

Quick Start

The MAX3170 EV kit is extremely flexible and has several settings for both the ICs as well as the board. The ICs have been put into no-cable mode, as the default mode. In no-cable mode the user is able to program the desired protocol with an external controller connected to the 40-pin header. The one exception is the INVERT signal, which does not have an internal pullup and is connected as a logic low for the default setting. The default mode settings are shown in Tables 1–4. By default, the SMA connectors (J3, J4, and J5) are terminated with 50Ω and the control transmitter input lines are all tied low.

- 1) Connect a single +3.3V ±5% power supply to VCC and GND located at the lower-left corner of the MAX3170 EV kit board.
- 2) The yellow LEDs indicate the protocol mode of the chipset. The LEDs will light when the corresponding signal is a logic high. Verify that all yellow LEDs

light, indicating no-cable mode. All board labels, including all of the labels for the LEDs, follow the same label format. The board label format includes a top label which corresponds to DCE mode, and a bottom label which corresponds to DTE mode.

- 3) The green LEDs are attached to the receiver logic outputs of the MAX3170 and MAX3171. The LEDs will light when the receiver logic outputs are a logic high. Verify that all green LEDs light when no signals are attached to the DB25 connector. **Note:** The receivers have the true fail-safe feature allowing zero differential voltage to be a valid state, which forces the receiver outputs high.
- 4) The red LEDs are attached to the transmitter logic inputs of the MAX3170 and MAX3171. The LEDs will light when the transmitter logic inputs are a logic high. Verify that none of the red LEDs light when no signals are connected to the 40-pin header.

Detailed Description

The MAX3170 EV kit was designed to take advantage of the chipset's flow-through pinout. The logic signals have all been routed to the 40-pin header (located on the left side of the EV kit board), and the protocol signals have all been routed to the female DB25 connector (located on the right side of the board).

Various connectors have been added to the MAX3170 EV kit to aid in taking quality measurements. Leave JU19 unconnected when measuring the supply current of the chipset. Scope probe connectors have been added to measure the high-speed signals of the transmitter and receiver inputs and outputs of the MAX3170. The scope probe connectors located on the left side of the board are connected to the logic input and output signals. The scope probe connectors located on the right side of the board are connected to the protocol input and output signals. Three SMA connectors also have been provided for driving the MAX3170's high-speed transmitter inputs. The 16 LEDs across the top of the board are logic indicators. The red LEDs indicate the state of the transmitter inputs, the green LEDs indicate the state of the receiver outputs, and the yellow LEDs indicate the state of the protocol and the protocol termination modes of the MAX3170 and MAX3171. The LEDs will light up when their corresponding signals are logic high.

MAX3170 Evaluation Kit

Evaluates: MAX3170/MAX3171/MAX3172

Table 1. MAX3170 Default Mode

MODE	M2	M1	M0	DCE/DTE	T1	T2	T3	R1	R2	R3
No cable	1	1	1	1	Z	Z	Z	Z	Z	Z

Z = High impedance.

Note: Shaded areas share a single IC pin.

Table 2. MAX3171 Default Mode

MODE	M2	M1	M0	DCE/DTE	T1	T2	T3	R1	R2	R3
No cable	1	1	1	1	Z	Z	Z	Z	Z	Z

Z = High Impedance.

Note: Shaded areas share a single IC pin.

Table 3. MAX3172 R4/T4 Default Mode

MODE	M2	M1	M0	DCE/DTE	INVERT	T4	R4
No cable	1	1	1	1	0	Z	Z

Z = High impedance.

Table 4. MAX3172 Default Termination Mode

MODE	M2	M1	M0	DCE/DTE	INVERT	R1	R2	R3	R4	R5
No cable	1	1	1	1	0	V.11	V.11	V.11	V.11	V.11

Configuration

The following is a step-by-step procedure to configure the MAX3170 EV kit. The MAX3170 EV kit is extremely flexible and has several settings for both the ICs, as well as the board. The logic signals have all been routed to the 40-pin header on the left side of the board. The protocol signals have all been routed to the female DB25 connector on the right side of the board.

The chipset protocol modes can be configured to support V.28 (RS-232), V.11 (RS-449/V.36, EIA-530, EIA-530A, X.21), and V.35 protocols. All chipset logic inputs, LED power, and shield ground connection are jumper selectable. The board includes SMA connectors (J3, J4, and J5) with optional 50Ω termination. The board settings will be separated in the following sections: chipset protocol modes, clock/data transmitter

input settings, control transmitter input settings, SMA termination, and power/ground.

- 1) Connect a single +3.3V ±5% power supply to VCC and GND located at the lower-left corner of the MAX3170 EV kit board.
- 2) Chipset protocol modes:

View the desired chipset protocol mode using the MAX3170, MAX3171, and MAX3172 selection mode tables (Tables 5–8). Connect the jumpers to the corresponding state depending on whether the mode lines will be controlled by an external controller or pin-strapped to a known state using Tables 9 and 10. Unlike the other IC protocol mode lines (M2, M1, M0, and DCE/DTE), the INVERT line does not have a pullup.

MAX3170 Evaluation Kit

3) Clock/data transmitter input settings:

Connect the clock/data jumpers to the corresponding state using Table 11. Force the inputs of all unused transmitters low so their corresponding LED indicators will be off.

4) Control transmitter input settings:

Connect the control jumpers to the corresponding state using Table 12. Force the inputs of all unused transmitters low so their corresponding LED indicators will be off.

5) SMA termination:

Connect the termination jumpers, depending on whether the signal source needs to be terminated

with 50Ω, to the corresponding state using Table 13. Leave unused transmitter input lines terminated so the line is pulled down in a known state. When using SMA termination, avoid connecting JU1, JU2, and JU3 to VCC.

6) Power/ground:

Connect the power and ground jumpers according to the desired operation using Table 14. Leave JU19 unconnected (open) when measuring the supply current of the chipset.

Table 5. MAX3170 Mode Selection

MODE	M2	M1	M0	DCE/DTE	T1	T2	T3	R1	R2	R3
V.11	0	0	0	0	V.11	V.11	Z	V.11	V.11	V.11
RS-530A	0	0	1	0	V.11	V.11	Z	V.11	V.11	V.11
RS-530	0	1	0	0	V.11	V.11	Z	V.11	V.11	V.11
X.21	0	1	1	0	V.11	V.11	Z	V.11	V.11	V.11
V.35	1	0	0	0	V.35	V.35	Z	V.35	V.35	V.35
RS-449/V.36	1	0	1	0	V.11	V.11	Z	V.11	V.11	V.11
V.28/RS-232	1	1	0	0	V.28	V.28	Z	V.28	V.28	V.28
No cable	1	1	1	0	Z	Z	Z	Z	Z	Z
V.11	0	0	0	1	V.11	V.11	V.11	Z	V.11	V.11
RS-530A	0	0	1	1	V.11	V.11	V.11	Z	V.11	V.11
RS-530	0	1	0	1	V.11	V.11	V.11	Z	V.11	V.11
X.21	0	1	1	1	V.11	V.11	V.11	Z	V.11	V.11
V.35	1	0	0	1	V.35	V.35	V.35	Z	V.35	V.35
RS-449/V.36	1	0	1	1	V.11	V.11	V.11	Z	V.11	V.11
V.28/RS-232	1	1	0	1	V.28	V.28	V.28	Z	V.28	V.28
No cable	1	1	1	1	Z	Z	Z	Z	Z	Z

Z = High impedance.

Note: Shaded areas share a single IC pin.

MAX3170 Evaluation Kit

Evaluates: MAX3170/MAX3171/MAX3172

Table 6. MAX3171 Mode Selection

MODE	M2	M1	M0	DCE/DTE	T1	T2	T3	R1	R2	R3
V.11	0	0	0	0	V.11	V.11	Z	V.11	V.11	V.11
RS-530A	0	0	1	0	V.11	V.10	Z	V.11	V.10	V.11
RS-530	0	1	0	0	V.11	V.11	Z	V.11	V.11	V.11
X.21	0	1	1	0	V.11	V.11	Z	V.11	V.11	V.11
V.35	1	0	0	0	V.28	V.28	Z	V.28	V.28	V.28
RS-449/V.36	1	0	1	0	V.11	V.11	Z	V.11	V.11	V.11
V.28/RS-232	1	1	0	0	V.28	V.28	Z	V.28	V.28	V.28
No cable	1	1	1	0	Z	Z	Z	Z	Z	Z
V.11	0	0	0	1	V.11	V.11	V.11	Z	V.11	V.11
RS-530A	0	0	1	1	V.11	V.10	V.11	Z	V.10	V.11
RS-530	0	1	0	1	V.11	V.11	V.11	Z	V.11	V.11
X.21	0	1	1	1	V.11	V.11	V.11	Z	V.11	V.11
V.35	1	0	0	1	V.28	V.28	V.28	Z	V.28	V.28
RS-449/V.36	1	0	1	1	V.11	V.11	V.11	Z	V.11	V.11
V.28/RS-232	1	1	0	1	V.28	V.28	V.28	Z	V.28	V.28
No cable	1	1	1	1	Z	Z	Z	Z	Z	Z

Z = High impedance.

Note: Shaded areas share a single IC pin.

MAX3170 Evaluation Kit

Evaluates: MAX3170/MAX3171/MAX3172

Table 7. MAX3172 R4/T4 Mode Selection

MODE	M2	M1	M0	DCE/DTE	INVERT	T4	R4
V.11	0	0	0	0	0	Z	V.10
RS-530A	0	0	1	0	0	Z	V.10
RS-530	0	1	0	0	0	Z	V.10
X.21	0	1	1	0	0	Z	V.10
V.35	1	0	0	0	0	Z	V.28
RS-449/V.36	1	0	1	0	0	Z	V.10
V.28/RS-232	1	1	0	0	0	Z	V.28
No cable	1	1	1	0	0	Z	Z
V.11	0	0	0	1	0	V.10	Z
RS-530A	0	0	1	1	0	V.10	Z
RS-530	0	1	0	1	0	V.10	Z
X.21	0	1	1	1	0	V.10	Z
V.35	1	0	0	1	0	V.28	Z
RS-449/V.36	1	0	1	1	0	V.10	Z
V.28/RS-232	1	1	0	1	0	V.28	Z
No cable	1	1	1	1	0	Z	Z
V.11	0	0	0	0	1	V.10	Z
RS-530A	0	0	1	0	1	V.10	Z
RS-530	0	1	0	0	1	V.10	Z
X.21	0	1	1	0	1	V.10	Z
V.35	1	0	0	0	1	V.28	Z
RS-449/V.36	1	0	1	0	1	V.10	Z
V.28/RS-232	1	1	0	0	1	V.28	Z
No cable	1	1	1	0	1	Z	Z
V.11	0	0	0	1	1	Z	V.10
RS-530A	0	0	1	1	1	Z	V.10
RS-530	0	1	0	1	1	Z	V.10
X.21	0	1	1	1	1	Z	V.10
V.35	1	0	0	1	1	Z	V.28
RS-449/V.36	1	0	1	1	1	Z	V.10
V.28/RS-232	1	1	0	1	1	Z	V.28
No cable	1	1	1	1	1	Z	Z

Z = High impedance.

MAX3170 Evaluation Kit

Evaluates: MAX3170/MAX3171/MAX3172

Table 8. MAX3172 Termination Mode Selection

MODE	M2	M1	M0	DCE/DTE	INVERT	R1	R2	R3	R4	R5
V.11 (Unterminated)	0	0	0	0	X	Z	Z	Z	Z	Z
RS-530A	0	0	1	0	X	Z	Z	V.11	V.11	V.11
RS-530	0	1	0	0	X	Z	Z	V.11	V.11	V.11
X.21	0	1	1	0	X	Z	Z	V.11	V.11	V.11
V.35	1	0	0	0	X	V.35	V.35	V.35	V.35	V.35
RS-449/V.36	1	0	1	0	X	Z	Z	V.11	V.11	V.11
V.28/RS-232	1	1	0	0	X	Z	Z	Z	Z	Z
No cable	1	1	1	0	X	V.11	V.11	V.11	V.11	V.11
V.11 (Unterminated)	0	0	0	1	X	Z	Z	Z	Z	Z
RS-530A	0	0	1	1	X	Z	Z	Z	V.11	V.11
RS-530	0	1	0	1	X	Z	Z	Z	V.11	V.11
X.21	0	1	1	1	X	Z	Z	Z	V.11	V.11
V.35	1	0	0	1	X	V.35	V.35	V.35	V.35	V.35
RS-449/V.36	1	0	1	1	X	Z	Z	Z	V.11	V.11
V.28/RS-232	1	1	0	1	X	Z	Z	Z	Z	Z
No cable	1	1	1	1	X	V.11	V.11	V.11	V.11	V.11

Z = High impedance.

Table 9. Chipset Protocol Mode Jumper Settings

JUMPER	SIGNAL (BUS)	STATE	FUNCTION
JU14	DCE/DTE	Open*	Logic high. (Internal pullup in IC.) DCE/DTE line can be driven by signal applied to J1-30 (40-pin header).
		Closed	Logic low
JU15	M2	Open*	Logic high. (Internal pullup in IC.) M2 line can be driven by signal applied to J1-32 (40-pin header).
		Closed	Logic low
JU16	M1	Open*	Logic high. (Internal pullup in IC.) M1 line can be driven by signal applied to J1-34 (40-pin header).
		Closed	Logic low
JU17	M0	Open*	Logic high. (Internal pullup in IC.) M0 line can be driven by signal applied to J1-36 (40-pin header).
		Closed	Logic low

*Default jumper setting.

MAX3170 Evaluation Kit

Evaluates: MAX3170/MAX3171/MAX3172

Table 10. Invert Mode Jumper Settings

JUMPER	SIGNAL	STATE	FUNCTION
JU12	INVERT	1-2*	Logic high
		2-3	Logic low
		Open	Apply signal to J1-38 (40-pin header)

*Default jumper setting.

Table 11. Clock/Data Transmitter Input Jumper Settings

JUMPER	DCE/DTE	STATE	FUNCTION
JU1	RXD/TXD	1-2	Logic high
		2-3	Logic low
		Open*	Apply signal to SMA connector J3
JU2	RXC/SCTE	1-2	Logic high
		2-3	Logic low
		Open*	Apply signal to SMA connector J4
JU3	TXC/N/A	1-2	Logic high
		2-3	Logic low
		Open*	Apply signal to SMA connector J5

*Default jumper setting.

Table 12. Control Transmitter Input Jumper Settings

JUMPER	DCE/DTE	STATE	FUNCTION
JU4	CTS/RTS	1-2	Logic high
		2-3*	Logic low
		Open	Apply signal to J1-14 (40-pin header)
JU5	DSR/DTR	1-2	Logic high
		2-3*	Logic low
		Open	Apply signal to J1-16 (40-pin header)
JU6	DCD/N/A	1-2	Logic high
		2-3*	Logic low
		Open	Apply signal to J1-18 (40-pin header)
JU7	LL/N/A	1-2	Logic high
		2-3*	Logic low
		Open	Apply signal to J1-26 (40-pin header)

*Default jumper setting.

MAX3170 Evaluation Kit

Evaluates: MAX3170/MAX3171/MAX3172

Table 13. Termination settings

JUMPER	DCE/DTE	STATE	FUNCTION
JU8	RXD/TXD	Open	Unterminated
		Closed*	Terminated with 50Ω
JU9	RXC/SCTE	Open	Unterminated
		Closed*	Terminated with 50Ω
JU10	TXC/ N/A	Open	Unterminated
		Closed*	Terminated with 50Ω

*Default jumper setting.

Table 14. Power/Ground Jumper Settings

JUMPER	NAME	STATE	FUNCTION
JU11	SHIELD	Open	DB25 cable shield (J2-1) disconnected from signal ground
		Closed*	DB25 cable shield (J2-1) shorted to signal ground
JU19	LED ANODE	Open	LED anode is floating
		Closed*	LED anode is connected to VCC

*Default jumper setting.

Evaluates: MAX3170/MAX3171/MAX3172

MAX3170 Evaluation Kit

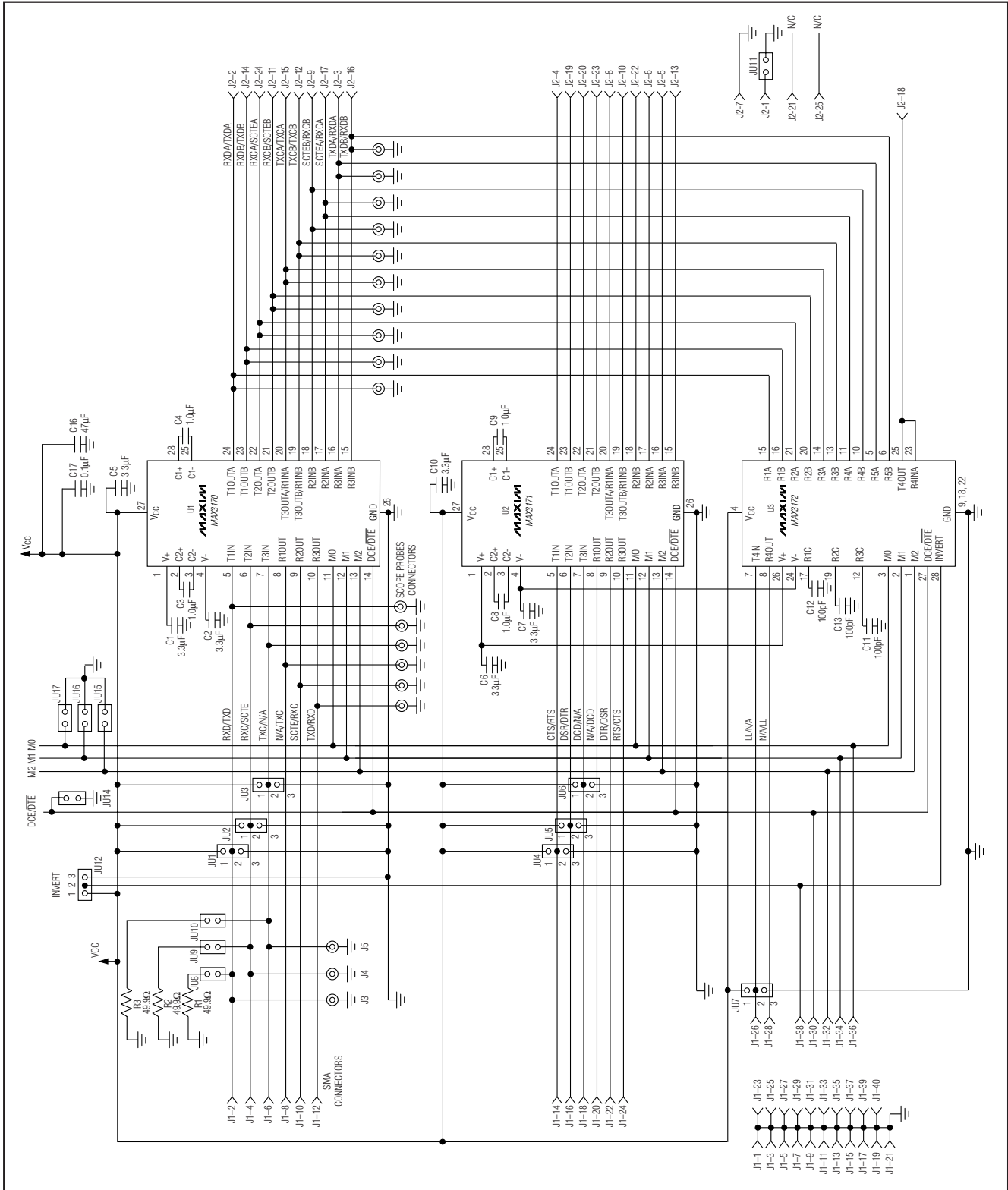

Figure 1. MAX3170 EV Kit Schematic (Sheet 1 of 2)

MAX3170 Evaluation Kit

Evaluates: MAX3170/MAX3171/MAX3172

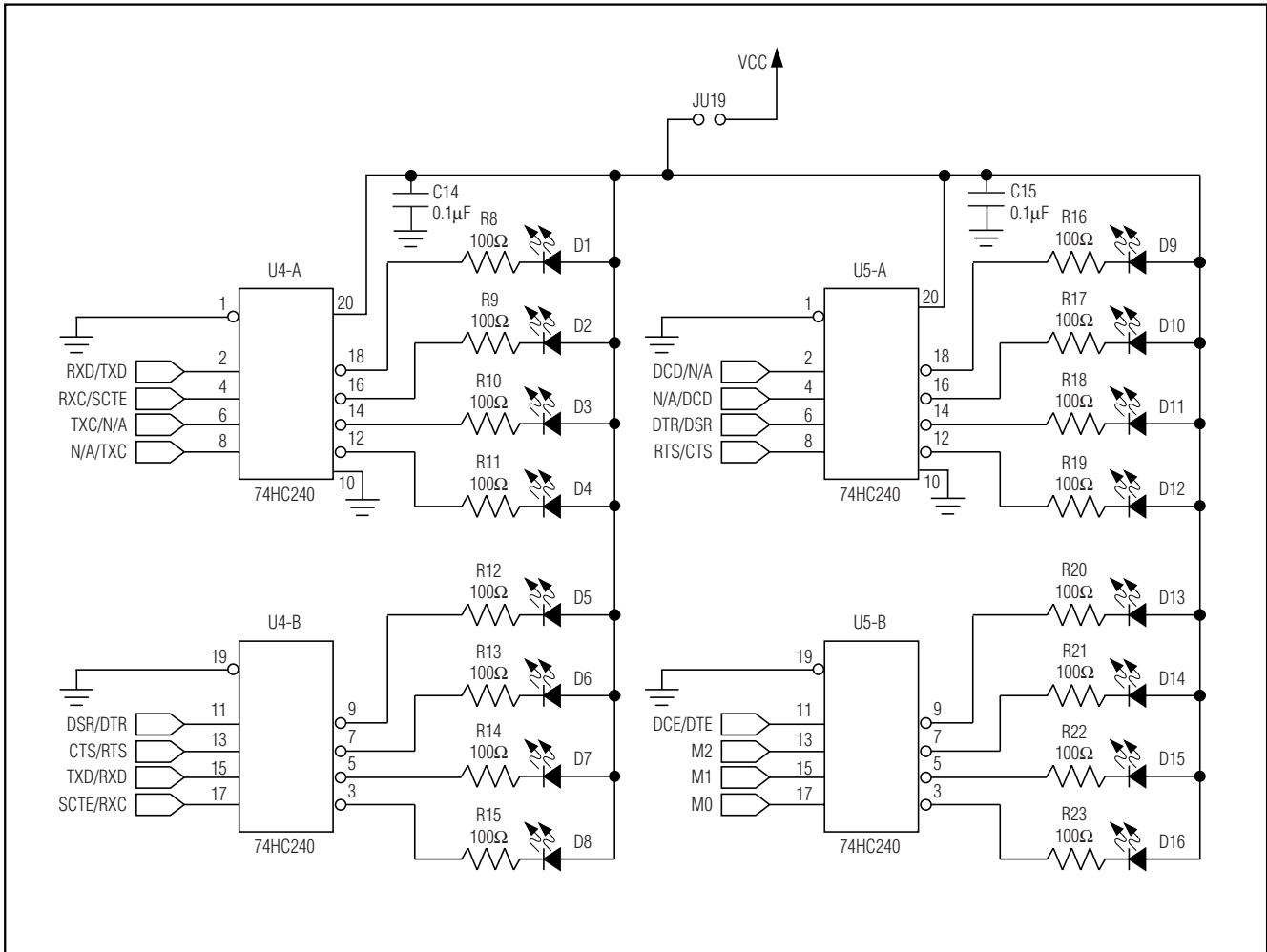

Figure 1. MAX3170 EV Kit Schematic (Sheet 2 of 2)

MAX3170 Evaluation Kit

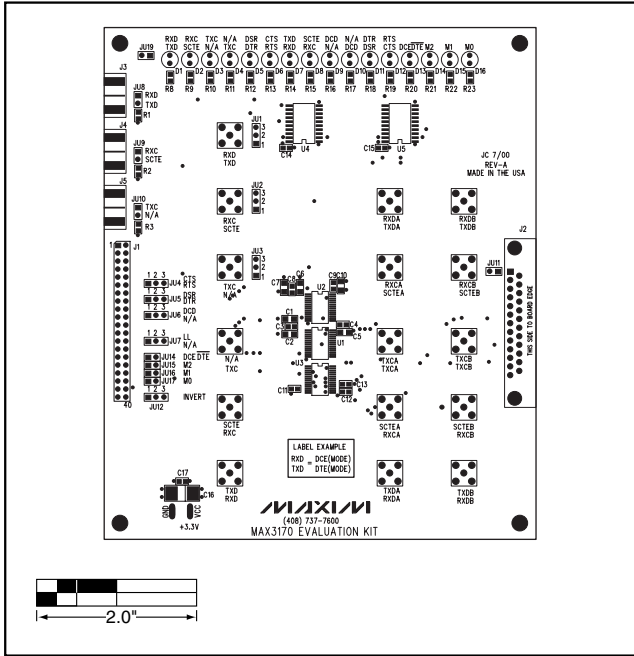

Figure 2. MAX3170 EV Kit Component Placement Guide—Top Layer (Silkscreen)

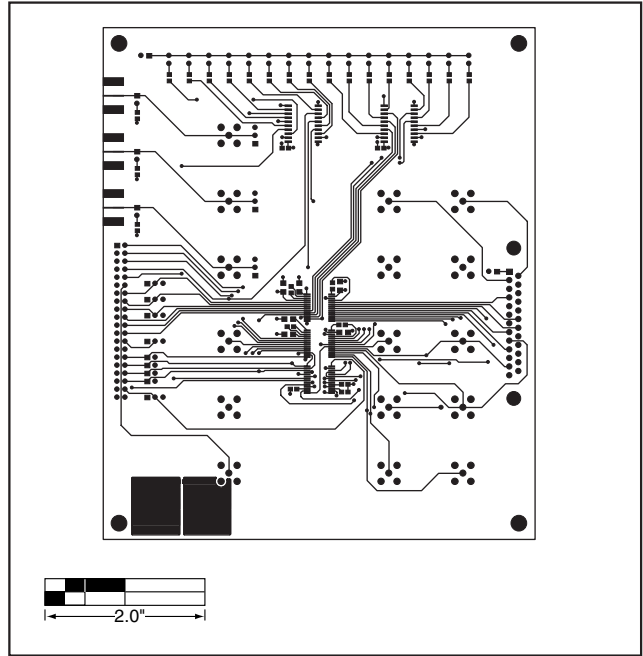

Figure 3. MAX3170 EV Kit Component Placement Guide—Top Layer (Component Side)

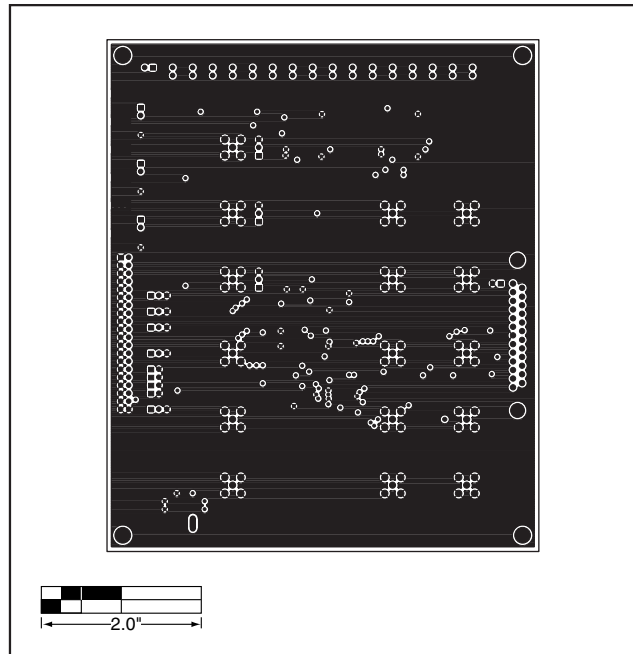

Figure 4. MAX3170 EV Kit PC Board Layout—Inner Layer 2 (GND)

MAX3170 Evaluation Kit

Evaluates: MAX3170/MAX3171/MAX3172

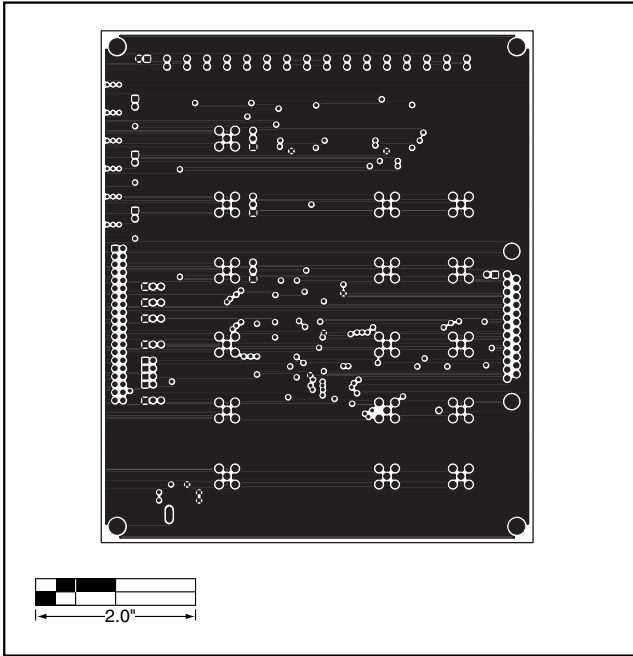

Figure 5. MAX3170 EV Kit PC Board Layout—Inner Layer 3 (VCC)

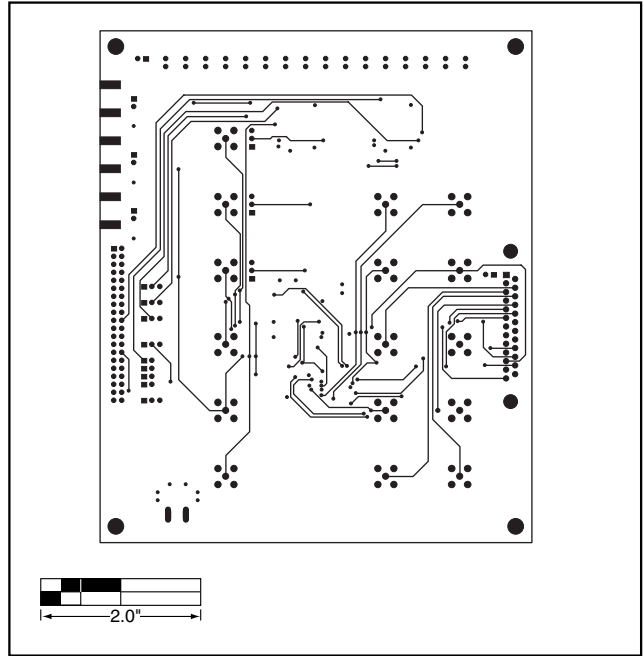

Figure 6. MAX3170 EV Kit PC Board Layout—Bottom Layer (Solder Side)

Maxim cannot assume responsibility for use of any circuitry other than circuitry entirely embodied in a Maxim product. No circuit patent licenses are implied. Maxim reserves the right to change the circuitry and specifications without notice at any time.

Maxim Integrated Products, 120 San Gabriel Drive, Sunnyvale, CA 94086 408-737-7600 _____13



Компания «ЭлектроПласт» предлагает заключение долгосрочных отношений при поставках импортных электронных компонентов на взаимовыгодных условиях!

Наши преимущества:

- Оперативные поставки широкого спектра электронных компонентов отечественного и импортного производства напрямую от производителей и с крупнейших мировых складов;
- Поставка более 17-ти миллионов наименований электронных компонентов;
- Поставка сложных, дефицитных, либо снятых с производства позиций;
- Оперативные сроки поставки под заказ (от 5 рабочих дней);
- Экспресс доставка в любую точку России;
- Техническая поддержка проекта, помощь в подборе аналогов, поставка прототипов;
- Система менеджмента качества сертифицирована по Международному стандарту ISO 9001;
- Лицензия ФСБ на осуществление работ с использованием сведений, составляющих государственную тайну;
- Поставка специализированных компонентов (Xilinx, Altera, Analog Devices, Intersil, Interpoint, Microsemi, Aeroflex, Peregrine, Syfer, Eurofarad, Texas Instrument, Miteq, Cobham, E2V, MA-COM, Hittite, Mini-Circuits, General Dynamics и др.);

Помимо этого, одним из направлений компании «ЭлектроПласт» является направление «Источники питания». Мы предлагаем Вам помощь Конструкторского отдела:

- Подбор оптимального решения, техническое обоснование при выборе компонента;
- Подбор аналогов;
- Консультации по применению компонента;
- Поставка образцов и прототипов;
- Техническая поддержка проекта;
- Защита от снятия компонента с производства.



Как с нами связаться

Телефон: 8 (812) 309 58 32 (многоканальный)

Факс: 8 (812) 320-02-42

Электронная почта: org@eplast1.ru

Адрес: 198099, г. Санкт-Петербург, ул. Калинина, дом 2, корпус 4, литера А.