

SERIES 86
Unsealed, .500" Centers,
Flange Mounted

FEATURES

- 1/2" Button Centers
- Flange Mounted
- Top Surface or Sub Surface Mounting
- Snap-Dome Contact Provides Positive Feedback



DIMENSIONS In inches (and millimeters)

3x4 Keyboard

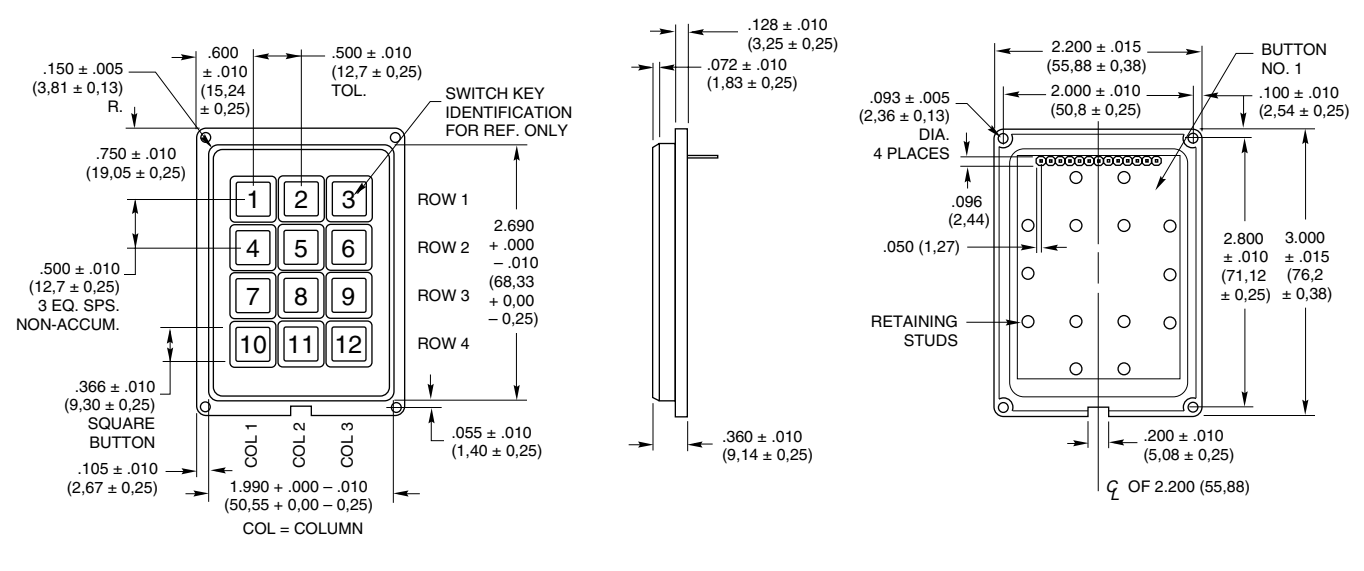

Termination In inches (and millimeters)

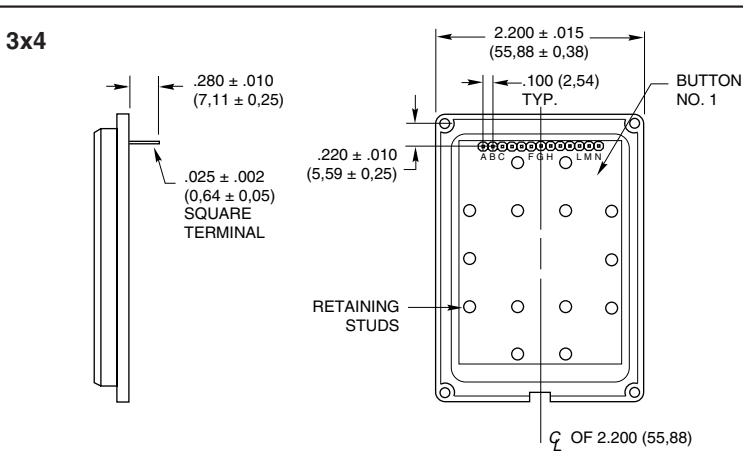

Code and Truth Table

Dots in the chart indicate connected terminals when switch is closed. Terminals are identified on the keyboard.

| 3x4 | | CODES | | | | | | | | | | | | | | | | | | | | | |
|-----------------|----|-------------------|---|---|---|---|---|---|---|------------------------|---|---|---|---|---|---|---|---|---|---|---|--|--|
| | | Matrix | | | | | | | | Single Pole/Common Bus | | | | | | | | | | | | | |
| BUTTON LOCATION | 1 | • | | | | | | | | | | | | | | | | | | | | | |
| | 2 | • | • | • | | | | | | • | | | | | | | • | | | | | | |
| | 3 | | | | | | | | | | | | | | | | | | | | | | |
| | 4 | • | | | | | | | | | • | | | | | | • | | | | | | |
| | 5 | | | | | | | | | | | | | | | | | | | | | | |
| | 6 | | | | | | | | | | | | | | | | | | | | | | |
| | 7 | • | | | | | | | | | | | | | | | • | | | | | | |
| | 8 | | | | | | | | | | | | | | | | | | | | | | |
| | 9 | | | | | | | | | | | | | | | | | | | | | | |
| | 10 | | | | | | | | | | | | | | | | | | | | | | |
| | 11 | • | | | | | | | | | | | | | | | • | | | | | | |
| | 12 | | | | | | | | | | | | | | | | | | | | | | |
| | | F | E | D | K | J | H | G | J | E | A | K | F | B | L | G | C | M | H | D | N | | |
| | | TERMINAL LOCATION | | | | | | | | | | | | | | | | | | | | | |

SERIES 86

Unsealed, .500" Centers, Flange Mounted

FEATURES

- 1/2" Button Centers
- Flange Mounted
- Top Surface or Sub Surface Mounting
- Snap-Dome Contact Provides Positive Feedback



DIMENSIONS In inches (and millimeters)

4x4 Keyboard



Termination In inches (and millimeters)

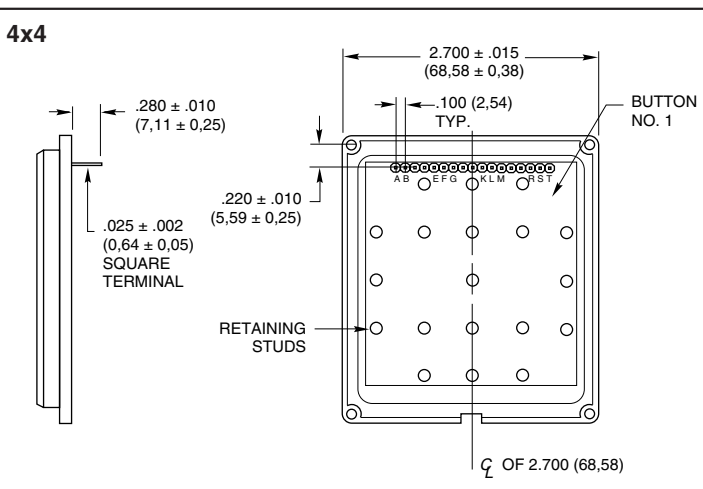

Code and Truth Table

Dots in the chart indicate connected terminals when switch is closed. Terminals are identified on the keyboard.

| 4x4 | CODES | |
|-----|-------------------|-----------------------------------|
| | Matrix | Single Pole/Common Bus |
| | Matrix | Single Pole/Common Bus |
| 1 | • | • |
| 2 | • | • |
| 3 | • | • |
| 4 | • | • |
| 5 | • | • |
| 6 | • | • |
| 7 | • | • |
| 8 | • | • |
| 9 | • | • |
| 10 | • | • |
| 11 | • | • |
| 12 | • | • |
| 13 | • | • |
| 14 | • | • |
| 15 | • | • |
| 16 | • | • |
| | H G F E M L K J | P J E A R L F B S M H C T N G D K |
| | TERMINAL LOCATION | |

SERIES 86
Unsealed, .500" Centers,
Flange Mounted

FEATURES

- 1/2" Button Centers
- Flange Mounted
- Top Surface or Sub Surface Mounting
- Snap-Dome Contact Provides Positive Feedback



DIMENSIONS In inches (and millimeters)

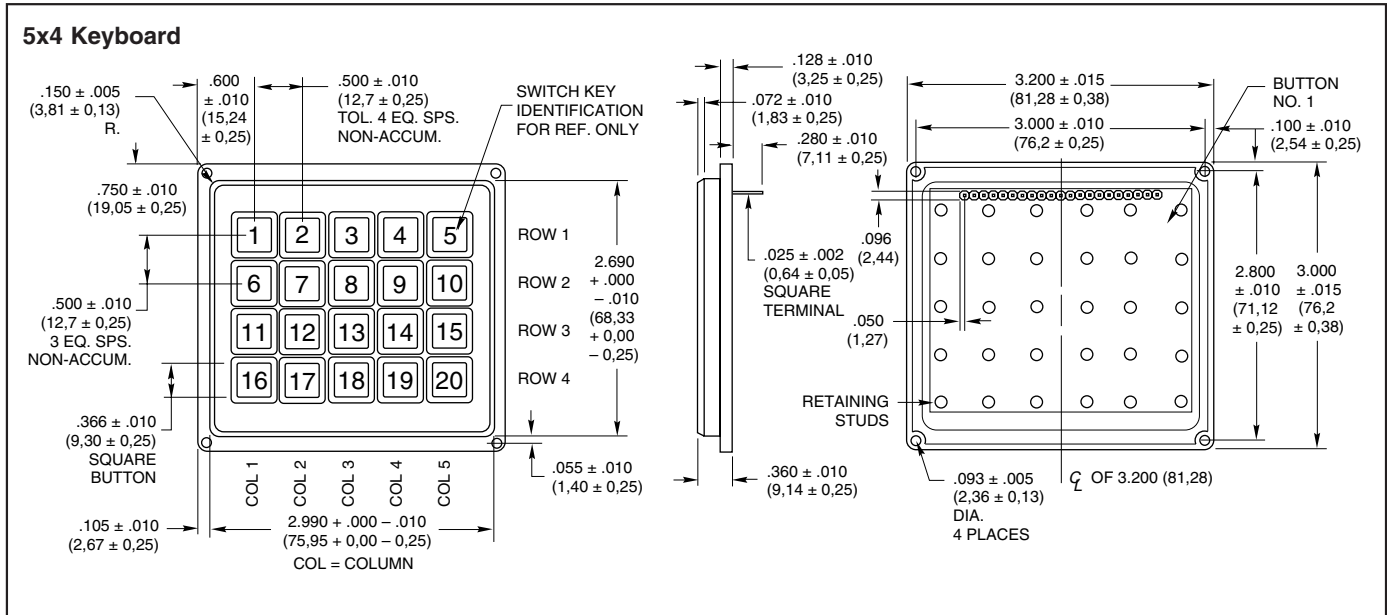

Termination In inches (and millimeters)

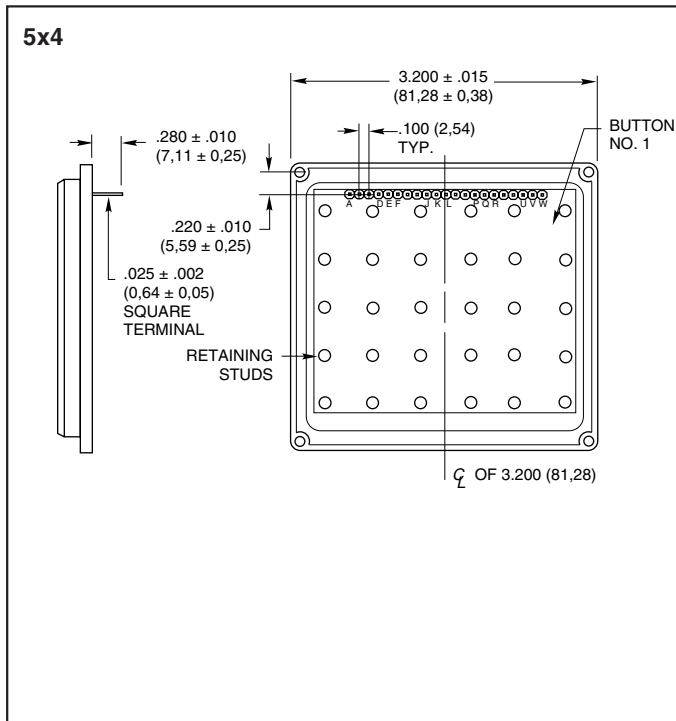

Code and Truth Table

Dots in the chart indicate connected terminals when switch is closed. Terminals are identified on the keyboard.

| | | CODES | | | |
|-----------------|----|-------------------|---|--|--|
| | | Matrix | Single Pole/Common Bus | | |
| BUTTON LOCATION | 1 | • | • | | |
| | 2 | • | • | | |
| | 3 | • | • | | |
| | 4 | • | • | | |
| | 5 | • | • | | |
| | 6 | • | • | | |
| | 7 | • | • | | |
| | 8 | • | • | | |
| | 9 | • | • | | |
| | 10 | • | • | | |
| | 11 | • | • | | |
| | 12 | • | • | | |
| | 13 | • | • | | |
| | 14 | • | • | | |
| | 15 | • | • | | |
| | 16 | • | • | | |
| | 17 | • | • | | |
| | 18 | • | • | | |
| | 19 | • | • | | |
| | 20 | • | • | | |
| | | P N K G F J L M H | T P M H D U Q L G C V R K F B W S J E A N | | |
| | | TERMINAL LOCATION | | | |

SPECIFICATIONS

Rating Criteria

Rating at 24 Vdc: 10 milliamps, resistive
Contact Resistance: Compatible with MOS, TTL and DTL (10 ohms maximum)
Voltage Breakdown: 250 Vac between mutually insulated parts
Life Expectancy: 3,000,000 operations per button

Contact Bounce: Less than 4 milliseconds at make, 10 milliseconds at break
Operating Temperature: -40°C to +80°C

Materials and Finishes

Housing: ABS polycarbonate, black
Buttons: ABS plastic, white. Legends are black.
Snap-On-Cap: Clear polycarbonate

Contact Dome: Stainless steel, selectively gold-plated
Terminals: Phosphor bronze

Operating Features

Button Travel: 0.015" nominal total travel
Typical Operating Force: 350 grams

STANDARD LEGENDS

Insertable legend version (legend numbers -101, -001, -201 and row or column indicated in -202 and -203) has a removable cap. The revealed button surface can be legended by an insert or a dry transfer of a blank legend

insert. This surface can also be ink stamped by Grayhill in higher volume quantities. When the cap is replaced, the assembly extends approximately .015" (0,38 mm) above the surface. The legend sheet information follows

the legend presentation. All other legends incorporate molded-in (two shot) legends with the exception of legend numbers -202 and -203. The blank legends or spaces in legends -202 and -203 are insertable legends, others are molded-in.

5x4: Shown below



INSERTABLE LEGENDS

For use with -101, -001, -201, -202 and -203 legend options. Legends are die cut to fit button surface when cap is removed. Dry transfer legends offer some flexibility to customize the blank inserts included on the sheet of popular legend letters, words and symbols provided or on the insertable legends sheet.

| Description | Part No. |
|--------------------------------|----------------|
| Sheet of Legend Inserts | 87AC2046 |
| Dry Transfer Lettering, Small | 87-DT-2096-088 |
| Dry Transfer Lettering, Medium | 87-DT-2096-125 |
| Dry Transfer Lettering, Large | 87-DT-2096-187 |

ORDERING INFORMATION

Grayhill Series Number

Size Option
 A = 3x4
 B = 4x4
 J = 5x4

Circuitry Option
 B2 = Matrix code
 C2 = Single pole/common bus

Standard Legend Choices
 3x4 Size: -101, -102 or -103
 4x4 Size: -001, -002, -003, -004, -005 or -006
 5x4 Size: -201, -202, or -203

86AB2-103

Available from your local Grayhill Distributor.
 For prices and discounts, contact a local Sales Office, an authorized local Distributor or Grayhill.



Компания «ЭлектроПласт» предлагает заключение долгосрочных отношений при поставках импортных электронных компонентов на взаимовыгодных условиях!

Наши преимущества:

- Оперативные поставки широкого спектра электронных компонентов отечественного и импортного производства напрямую от производителей и с крупнейших мировых складов;
- Поставка более 17-ти миллионов наименований электронных компонентов;
- Поставка сложных, дефицитных, либо снятых с производства позиций;
- Оперативные сроки поставки под заказ (от 5 рабочих дней);
- Экспресс доставка в любую точку России;
- Техническая поддержка проекта, помощь в подборе аналогов, поставка прототипов;
- Система менеджмента качества сертифицирована по Международному стандарту ISO 9001;
- Лицензия ФСБ на осуществление работ с использованием сведений, составляющих государственную тайну;
- Поставка специализированных компонентов (Xilinx, Altera, Analog Devices, Intersil, Interpoint, Microsemi, Aeroflex, Peregrine, Syfer, Eurofarad, Texas Instrument, Miteq, Cobham, E2V, MA-COM, Hittite, Mini-Circuits, General Dynamics и др.);

Помимо этого, одним из направлений компании «ЭлектроПласт» является направление «Источники питания». Мы предлагаем Вам помощь Конструкторского отдела:

- Подбор оптимального решения, техническое обоснование при выборе компонента;
- Подбор аналогов;
- Консультации по применению компонента;
- Поставка образцов и прототипов;
- Техническая поддержка проекта;
- Защита от снятия компонента с производства.



Как с нами связаться

Телефон: 8 (812) 309 58 32 (многоканальный)

Факс: 8 (812) 320-02-42

Электронная почта: org@eplast1.ru

Адрес: 198099, г. Санкт-Петербург, ул. Калинина, дом 2, корпус 4, литера А.