



UCC28514 User's Guide

User's Guide

EVM IMPORTANT NOTICE (CATEGORY B)

IMPORTANT: TI is providing the enclosed **HPA013B/HPA020A** evaluation module under the following conditions:

This evaluation module (EVM) being provided by Texas Instruments (TI) is intended for use for **ENGINEERING DEVELOPMENT OR EVALUATION PURPOSES ONLY** and is not considered by Texas Instruments to be fit for commercial use. As such, this EVM may not be complete in terms of design and/or manufacturing related protective considerations including product safety measures typically found in the end-product incorporating the module. As a prototype, this product does not fall within the scope of the European Union Directive on electromagnetic compatibility and on low voltage and therefore may not meet the technical requirements of the directive. This EVM is not subject to the EU marking requirements.

- Should this EVM not meet the specifications indicated in the User's Guide the EVM may be returned within 30 days from the date of delivery for a full refund. **THE FOREGOING WARRANTY IS THE EXCLUSIVE WARRANTY MADE BY TI AND IS IN LIEU OF ALL OTHER WARRANTIES, EXPRESSED, IMPLIED, OR STATUTORY, INCLUDING ANY WARRANTY OF MERCHANTABILITY OR FITNESS FOR ANY PARTICULAR PURPOSE.**
- The user assumes all responsibility and liability for proper and safe handling of the EVM. The user acknowledge that the use of the EVM could present serious hazards and that it is the user's responsibility to take all precautions for the handling and use of the EVMs in accordance with good laboratory practices. Please be aware that the products received may not be regulatory compliant or agency certified (FCC, UL, etc.). Due to the open construction of the product, it is the user's responsibility to take any and all appropriate precautions with regard to electrostatic discharge.
- **NEITHER PARTY WILL BE LIABLE TO THE OTHER FOR ANY INDIRECT, SPECIAL, INCIDENTAL, OR CONSEQUENTIAL DAMAGES.**
- TI is currently dealing with various customers for products, and therefore our arrangement with the user **will not be exclusive.**
- TI assumes **no liability for applications assistance, customer product design, software performance, or infringement of patents or services described herein.**
- Please read the User's Guide and specifically the section in the User's Guide pertaining to warnings and restrictions prior to handling the product. This section contains important information regarding high temperature and voltages which TI recommends to be read before handling the EVMs. In case of any doubt regarding safety, please contact the TI application engineer.
- Persons handling the product should have electronics training and observe good laboratory practice standards.
- No license is granted under any patent right or other intellectual property right of TI covering or relating to any combination, machine, or process in which such TI products or services might be or are used.
- This Agreement is subject to the laws of the State of Texas, excluding the body of conflicts of laws and the United Nations Convention on the International Sale of Goods, and will be subject to the exclusive jurisdiction of the courts of the State of Texas.

DYNAMIC WARNINGS AND RESTRICTIONS

It is important to operate this EVM within the maximum input voltage ranges specified in section 6.

Exceeding the specified input range may cause unexpected operation and/or irreversible damage to the EVM. If there are questions concerning the input range, please contact a TI field representative prior to connecting the input power.

Applying loads outside of the specified output range may result in unintended operation and/or possible permanent damage to the EVM. Please consult the EVM User's Guide prior to connecting any load to the EVM output. If there is uncertainty as to the load specification, please contact a TI field representative.

During normal operation, some circuit components may have case temperatures greater than 50°C. The EVM is designed to operate properly with certain components above 50°C as long as the input and output ranges are maintained. These components include but are not limited to linear regulators, switching transistors, pass transistors, and current sense resistors. These types of devices can be identified using the EVM schematic located in the EVM User's Guide. When placing measurement probes near these devices during operation, please be aware that these devices may be very warm to the touch.

Mailing Address:

Texas Instruments
Post Office Box 655303
Dallas, Texas 75265

Copyright © 2003, Texas Instruments Incorporated

UCC28514 User's Guide

Power Supply Control Products

Contents

1	Introduction	4
2	Caution	4
3	Schematic	5
4	List of Materials	8
5	Reference Design Layout	11
6	Electrical Characteristics	12
7	Reference Design Performance	13

1 Introduction

The UCC28514 module is a 100-W offline ac-to-dc voltage converter with power factor correction (PFC). The prototype was designed to show how the UCC28514 could be configured to control a dc-regulated output offline with one control integrated circuit. The module was design to operate over a universal input range of 85 V to 265 V with a regulated 24-V, 100-W output.

To correctly operate this EVM a fan is required to keep the ambient temperature at or below 40°C. Not keeping the temperature at or below 40°C could damage the EVM.

2 Caution

High-voltage levels are present on the evaluation module whenever it is energized. Proper precautions must be taken when working with the module. The evaluation module has a large energy storage capacitor and must be completely discharged before the module can be handled. Serious injury can occur if proper safety precautions are not followed.

3 Schematic

The schematic is broken up into three sections to make it more legible for the user.

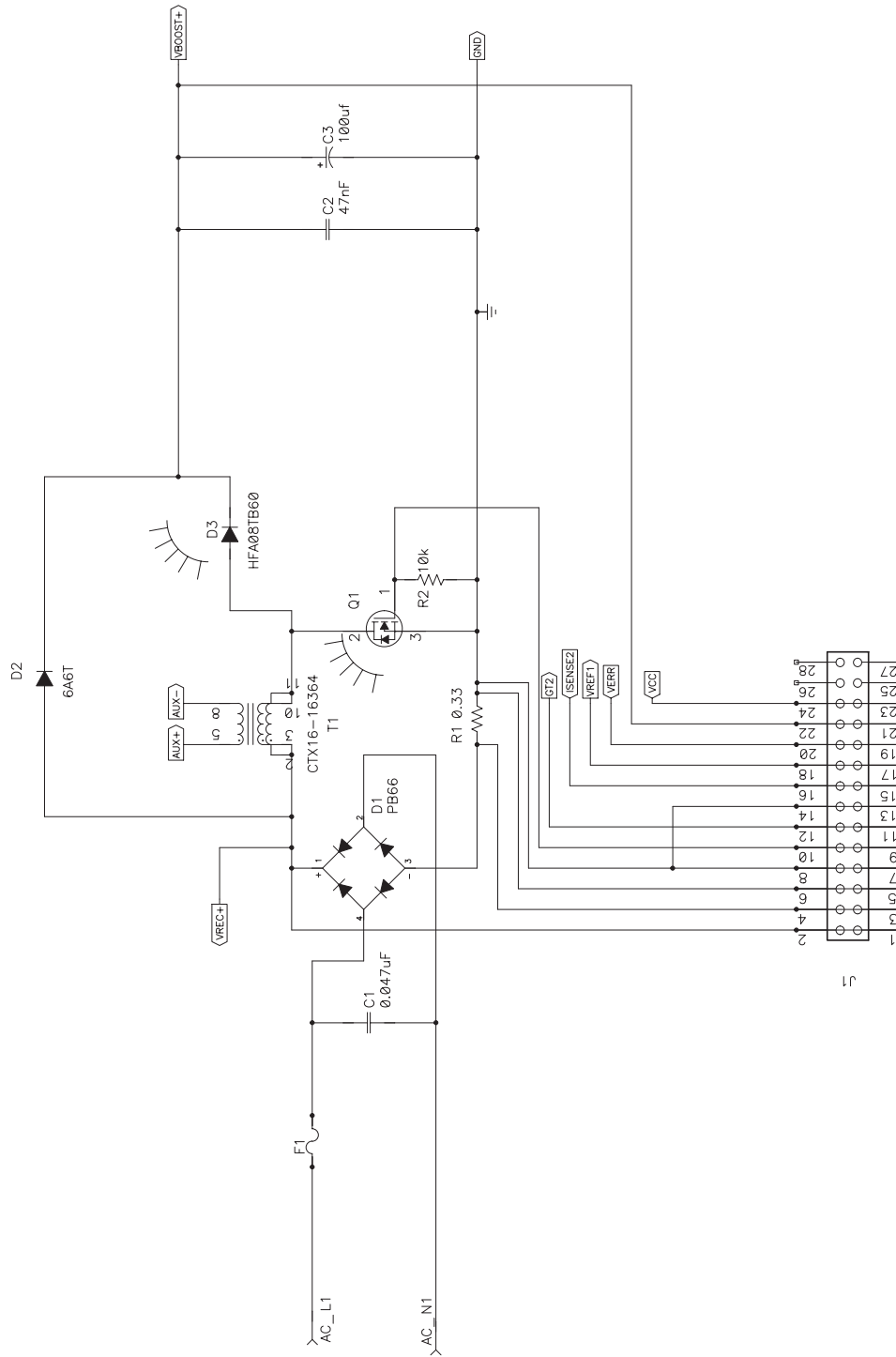

Figure 1. Mother Board HPA013

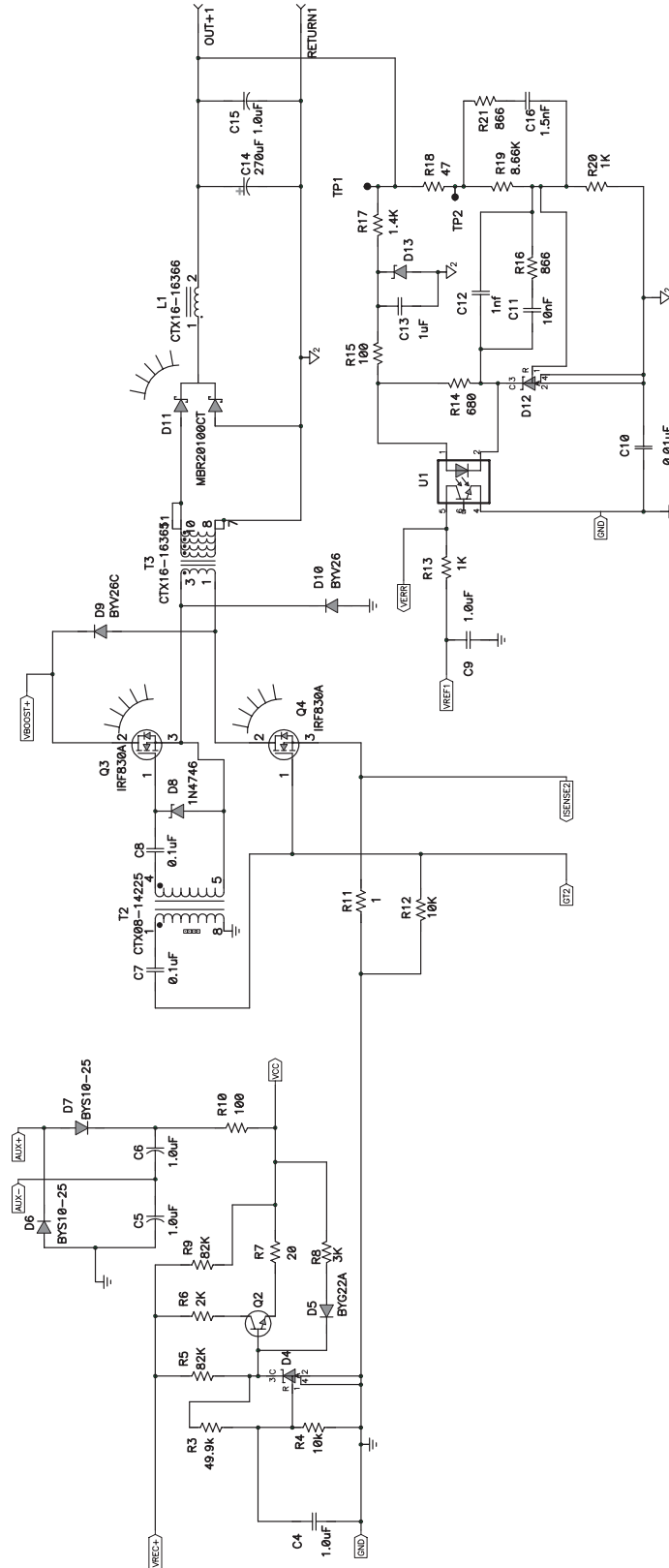

Figure 2. Mother Board HPA013

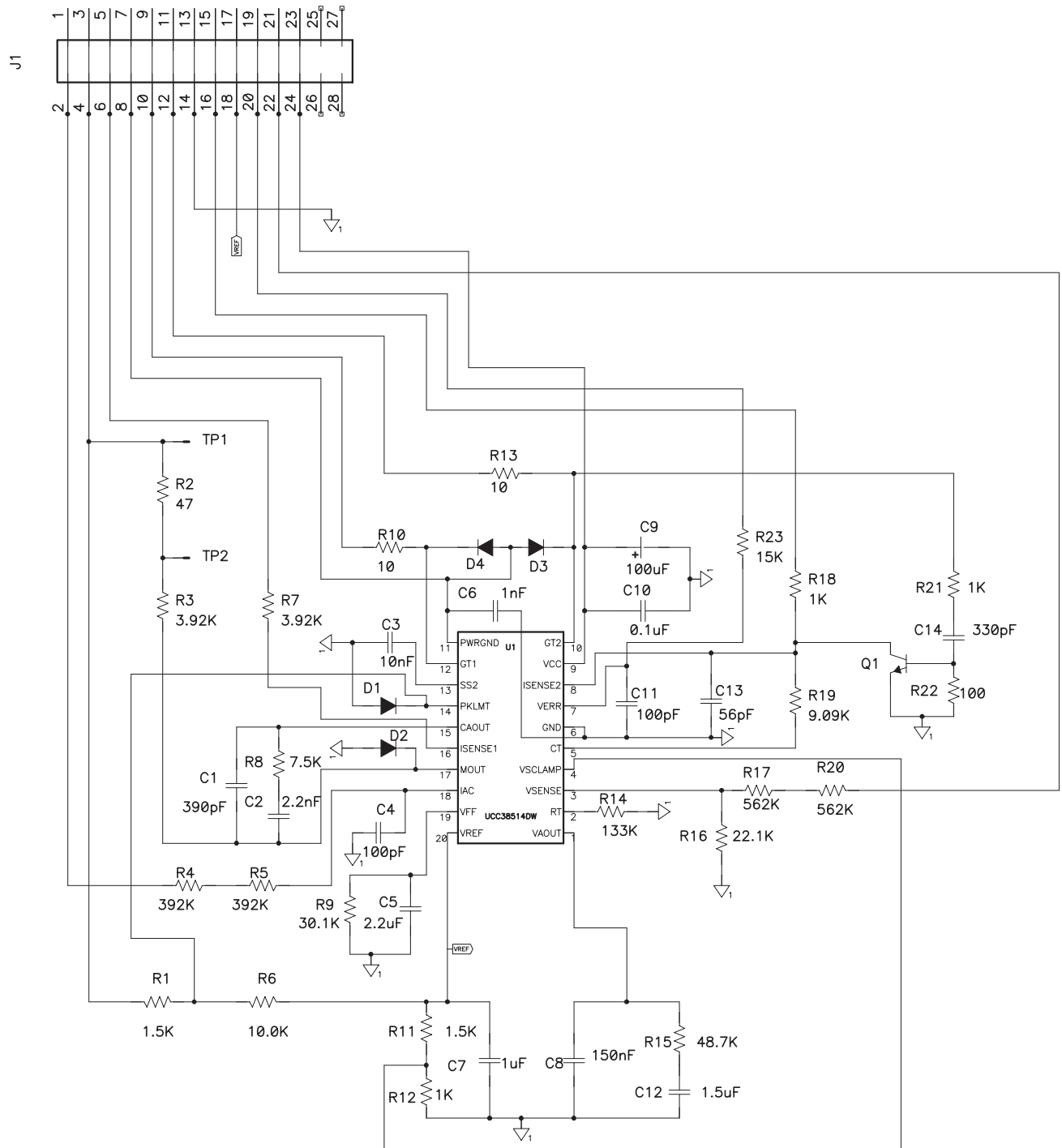

Figure 3. Daughter Board HPA020

4 List of Materials

Table 1 lists the components used in this design. With minor component tweaks this design could be modified to meet a wide range of applications.

Table 1. Mother Board List of Materials

REFERENCE	QTY	DESCRIPTION	MANUFACTURER	PART NUMBER
AC_L1	0	Connector, binding post, insulated, for standard banana plug, black, 15 A, 141860	Johnson	111-0703-001
AC_N1	0	Connector, binding post, insulated, for standard banana plug, red, 15 A, 141860	Johnson	111-0702-001
C1	1	Capacitor, film, 0.047 μ F, 300 V _{AC} , \pm 20%, 0.236 x 0.591	Panasonic	ECQU3A473MG
C2	1	Capacitor, polyester, .047 μ F, 630 V, 10%, 0.256 x 0.650	Panasonic	ECQ-E6473KZ
C3	1	Capacitor, electrolytic, 100 μ F, 450 V, TS series	Panasonic	ECO-S2WB101BA
C4, C9	2	Capacitor, ceramic, 1 μ F, 25 V, X7R, 10%, 1206	Panasonic	ECJ-3YB1E105K
C5, C6, C15	3	Capacitor, film, 1.0 μ F, 50 V, 5%, 7380	Panasonic	ECQ-V1H105JL
C7, C8	2	Capacitor, ceramic, 0.1 μ F, 50 V, X7R, \pm 10%, 43200	Panasonic	ECU-S1H104KBB
C10	1	Capacitor, film, 0.01 μ F, 300 V _{AC} , \pm 20%, 0.197 x 0.591	Panasonic	ECQU3A103MG
C11	1	Capacitor, ceramic, 0.01 μ F, 50 V, X7R, 10%, 1206	Panasonic – ECG	ECU-V1H103KBM
C12	1	Capacitor, ceramic, 1 nF, 50 V, X7R, 10%, 805	Panasonic	ECU-V1H102KBN
C13	1	Capacitor, ceramic, 1 μ F, 50 V, X7R, 10%, 1206	Panasonic	ECJ-3YB1E105K
C14	1	Capacitor, electrolytic, 270 μ F, 35 V, 0.394 x 0.630	Panasonic	EEUFC1V271
C16	1	Capacitor, ceramic, 0.0015 μ F, 50 V, X7R, 10%, 805	Panasonic	ECJ-2VB2D152K
Daughter Card	1	Controller board plugs into J1	Any	HPA020
D1	1	Bridge rectifier, 6 A, 600 V, GBJ series	General Semiconductor	PB66
D2	1	Diode, 600 V, 6 A, 400 A peak surge, 252000	Diodes Inc	6A6-T
D3	1	Diode, ultra fast, 8 A, 600 V, 5 mA	International Rectifier	HFA08TB60
D4, D12	2	Adjustable precision shunt regulator, SOT-89	Texas Instruments	TL431CPK
D5	1	Diode, rectifier, 2 A, 50 V, SMA	Vishay	BYG22A
D7, D6	2	Diode, schottky, 1.5 A, 25 V, SMA	Vishay	BYS10-25
D8	1	Diode, zener, 18 V, 83 mA, 1 W, DO-41	On Semi	1N4746
D10, D9	2	Diode, fast recovery, SOD-57	Phillips	BYV26
D11	1	Diode, dual schottky, 1.5 A, 100 V, TO220	OnSemi	MBR20100CT
D13	1	Diode, zener, 10 V, 35 mA, 350 mW, SOT23	Diodes Inc	BZX84C10-7
F1	1	Fuseholder, 1/4 fuses, 0.42	Cooper/Bussman	BK/1A1907-06
Fuse at F1	1	6 A, 250 V, 3AG Glass Fast Acting *Cartridge Type, 1.25" x 0.25"	Littlefuse	312 006
HS1	1	Heatsink, TO-220, vertical mount, 5°C/W, 0.5 x 1.38in.	Aavid	513201
HS2	1	Heatsink, TO-220, Vertical mount, 0.98 x 0.44	Aavid	579402B00000
HS3, HS4, HS5	3	Heatsink, TO-220, Vertical mount, 15°C/W, 0.5" x 0.95"	Aavid	593002B33402
J1**	1	Receptacle, female 28 pins, 0.197 x 1181	Hirose Electric	DF11-28DS-2DSA(xx)
L1**	1	Inductor, 50 μ H, 5.6 A, 21.5 m Ω , 1,102 X 1,102	Cooper	CTX16-16366
OUT+1	0	Connector, binding post, insulated, for standard banana plug, black, 15 A, 141860	Johnson	111-0703-001
PCB	1	Mother board	Any	HPA013
Q1, Q3, Q4**	3	MOSFET, N-channel, 500 V, 5 A, 1500 m Ω , TO-220	International Rectifier	IRF830A
Q2**	1	Bipolar, NPN, 400 V, 1 A, 15 W, DPAK	On Semi	MJD50

REFERENCE	QTY	DESCRIPTION	MANUFACTURER	PART NUMBER
R1	1	Resistor, wirewound, 3 W, axial, 187500	Huntington Electric	ALSR-3-.33-1%
R2, R4	2	Resistor, chip, 10 k Ω , 1/4 W, 1%, 1210	Panasonic	ERJ-14NF1002U
R3	1	Resistor, chip, 49.9 k Ω , 1/4 W, 1%, 1210	Panasonic	ERJ-14NF4992U
R5	1	Resistor, power metal film, 500 V, 3 W, 5 \pm %, 1,000 X 0.200	BCcomponents	5093NW82K00J08AFX
R6	1	Resistor, power metal film, 2 k Ω , 3 W, 5 \pm %, 1,000 X 0.200	BCcomponents	5093NW2K00J08AFX
R7	1	Resistor, chip, 20 Ω , 1/4 W, 5%, 1210	Panasonic	ERJ-14YJ200U
R8	1	Resistor, chip, 3 k Ω , 1/10 W, 1%, 805	Std	Std
R9	1	Resistor, power metal film, 82 k Ω , 3 W, 5 \pm %, 1,000 X 0.200	BCcomponents	5093NW82K00J08AFX
R10	1	Resistor, chip, 100 Ω , 1/4 W, 5%, 1210	Panasonic	ERJ-14YJ101U
R11	1	Resistor, metal oxide, 1.0 Ω , 1 W, 5%, 0.150 x 0.700	Yageo	RSF100JB-1R0
R12	1	Resistor, chip, 10 k Ω , 1/10 W, 1%, 805	Panasonic	ERJ-6ENF1002V
R13, R20	2	Resistor, chip, 1 k Ω , 1/10 W, 1%, 805	Panasonic	ERJ-6ENF1001V
R14	1	Resistor, chip, 680 Ω , 1/10 W, 1%, 805	Yageo America	9C08052A6800FKHFT
R15	1	Resistor, chip, 100 Ω , 1/10 W, 1%, 805	Std	Std
R16, R21	2	Resistor, chip, 866 Ω , 1/10 W, 1%, 805	Panasonic	ERJ-6ENF8660V
R17	1	Resistor, chip, 1.4 k Ω , 1/10 W, 1%, 805	Std	Std
R18	1	Resistor, chip, 47 Ω , 1/10 W, 1%, 805	Panasonic	ERA-S27J470V
R19	1	Resistor, chip, 8.66 k Ω , 1/10 W, 1%, 805	Panasonic	ERJ-6ENF8661V
RETURN1	0	Connector, binding post, insulated, for standard banana plug, black, 15 A, 141860	Johnson	111-0703-001
T1**	1	Boost Inductor, 20 primary, 1 secondary, 1.7 mH, 2.5 A, 1,260 x 1,220	Cooper	CTX16-16364
T2**	1	XFMR, 100 kHz, 750 μ H, toroid, ferrite	Coiltronics, Inc	CTX08-14225
T3**	1	Transformer, 5.78 primary, 1 secondary, 37 mH, 0.75 A, 1,260 x 1,220	Cooper	CTX16-16365
TP1, TP2	0	Jack, test point, circle	Farnell	240-3xx
U1**	1	Optocoupler, 5300 V, 100% center, SMD	Fairchild	4N36S
X1 at HS1, HS3, HS4, HS5	4	Thermal pad silicon TO220	BERQUIST	
X1 at HS1, HS3, HS4, HS5	4	Nut #6X32 (steel)		
X1 at HS1, HS3, HS4, HS5	4	Split lock washer #6(steel)		
X1 at HS1, HS3, HS4, HS5	4	Flat washer #6 (steel)		
X1 at HS1, HS3, HS4, HS5	4	Nylon shoulder washer #6		Keystone Electronics
X1 at HS1, HS3, HS4, HS5	4	Pan head screw #6-32X7/16 (steel)		

- NOTES: (1) These assemblies are ESD sensitive, ESD precautions shall be observed.
 (2) These assemblies must be clean and free from flux and all contaminants. Use of no clean flux is not acceptable.
 (3) These assemblies must comply with workmanship standards IPC-A-610 Class 2.
 (4) Reference designators marked with an asterisk (***) cannot be substituted. All other components can be substituted with equivalent MFG's components.

Table 2. Daughter Board List of Materials

REFERENCE	QTY	DESCRIPTION	MANUFACTURER	PART NUMBER
C1	1	Capacitor, ceramic, 390 pF, 50 V, X7R, 10%, 805	Panasonic	ECU-V1H391KBN
C2	1	Capacitor, ceramic, 2.2 nF, 50 V, X7R, 10%, 805	Panasonic	ECJ-2VB1H222K
C3, C6	2	Capacitor, ceramic, 10 nF, 50 V, X7R, 10%, 805	Panasonic	ECJ-2VB1H103K
C4, C11	2	Capacitor, ceramic, 100 pF, 50 V, X7R, 10%, 805	Panasonic	ECJ-2VC1H101J
C5	1	Capacitor, ceramic, 2.2 μF, 16 V, X7R, 10%, 1206	muRata	ECJ-3YB1C225K
C7	1	Capacitor, ceramic, 1 μF, 50 V, X7R, 10%, 1206	Panasonic	ECJ-3YB1E105K
C8	1	Capacitor, ceramic, 150 nF, 50 V, X7R, 10%, 805	Panasonic	ECJ-2YB1E154K
C9	1	Capacitor, aluminum, 100 μF, 25 V, 20% (FC Series), 0.2	Panasonic	EEU-FC1E101S
C10	1	Capacitor, ceramic, 0.1 μF, 50 V, X7R, 10%, 805	Panasonic	ECJ-2YB1H104K
C12	1	Capacitor, ceramic, 1.5 μF, 16 V, X7R, 10%, 1206	Panasonic	ECJ-3YB1C155K
C13	1	Capacitor, ceramic, 56 pF, 50 V, X7R, 10%, 805	Panasonic	ECJ-2VC1H560J
C14	1	Capacitor, ceramic, 330 pF, 50 V, X7R, 10%, 805	Yageo America	08052R331K9B20D
D1, D2, D3, D4	4	Diode, schottky, 500 mA, 25 V, SMA	Vishay Telefunken	BYS10-25
J1	1	Header, right angle 100 mil, 12 pin , 0.495 x 1,200	Hirose Electronic	DF11-28DP-2DS(22)
Q1	1	Bipolar, NPN, SOT23	Vishay Telefunken	MMBT2222A
R1, R11	2	Resistor, chip, 1.5 kΩ, 1/10 W, 1%, 805	Panasonic	ERJ-6ENF1501V
R2	1	Resistor, chip, 47 Ω, 1/10 W, 1%, 805	std	std
R3, R7	2	Resistor, chip, 3.92 kΩ, 1/10 W, 1%, 805	Panasonic	ERJ-6ENF3921V
R4, R5	2	Resistor, chip, 390 kΩ, 1/2 W, 1%, 2010	Std	Std
R6	1	Resistor, chip, 10 kΩ, 1/10 W, 1%, 805	Panasonic	ERJ-6ENF1002V
R8	1	Resistor, chip, 7.5 kΩ, 1/10 W, 1%, 805	Panasonic	ERJ-6ENF7501V
R9	1	Resistor, chip, 30.1 kΩ, 1/10 W, 1%, 805	Panasonic	ERJ-6ENF3012V
R10, R13	2	Resistor, chip, 10 Ω, 1/4 W, 1%, 1210	Panasonic	ERJ-14NF10R0U
R12, R18, R21	3	Resistor, chip, 1 kΩ, 1/10 W, 1%, 805	Panasonic	ERJ-6ENF1001V
R14	1	Resistor, chip, 133 kΩ, 1/10 W, 1%, 805	Yageo America	9C08052A1333FKH FT
R15	1	Resistor, chip, 48.7 kΩ, 1/10 W, 1%, 805	Panasonic	ERJ-6ENF4872V
R16	1	Resistor, chip, 22.1 kΩ, 1/4 W, 1%, 1210	Panasonic	ERJ-14NF2212U
R17, R20	2	Resistor, chip, 562 kΩ, 1/4 W, 1%, 1210	Panasonic	ERJ-8ENF5623V
R19	1	Resistor, chip, 9.09 kΩ, 1/10 W, 1%, 805	Std	Std
R22	1	Resistor, chip, 100 Ω, 1/10 W, 1%, 805	std	std
R23	1	Resistor, chip, 15 kΩ, 1/10 W, 1%, 805	std	std
TP1, TP2	0	Jack, test point, Clr,	Farnell	240-3xx
U1	1	IC, Bi CMOS PFC\PWM Controller, 273600	TI	UCC28514DW

- NOTES: (1) These assemblies are ESD sensitive, ESD precautions shall be observed.
(2) These assemblies must be clean and free from flux and all contaminants. Use of no clean flux is not acceptable.
(3) These assemblies must comply with workmanship standards IPC-A-610 Class 2.
(4) Ref designators marked with an asterisk (***) cannot be substituted. All other components can be substituted with equivalent MFG's components.

5 Reference Design Layout

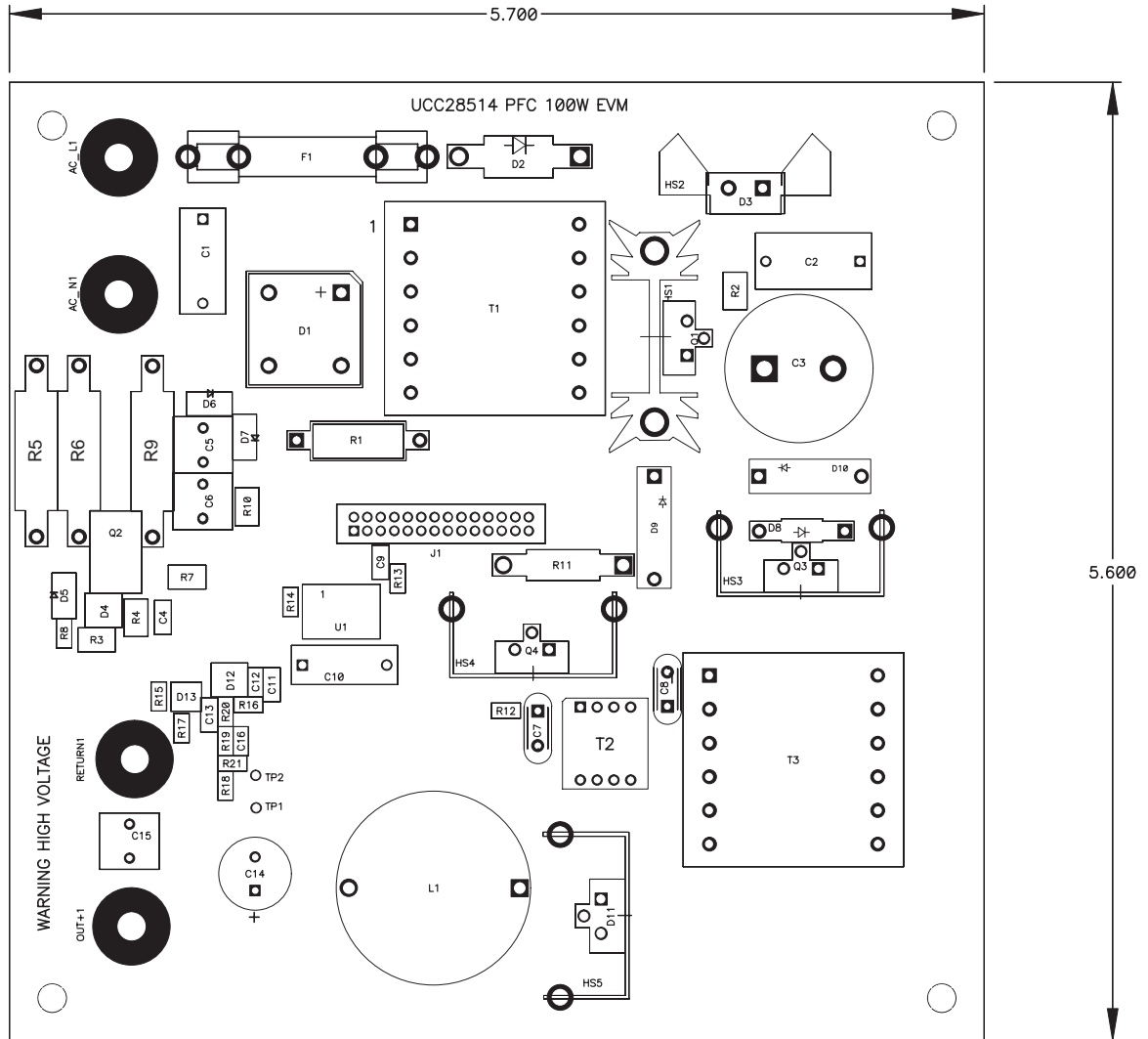
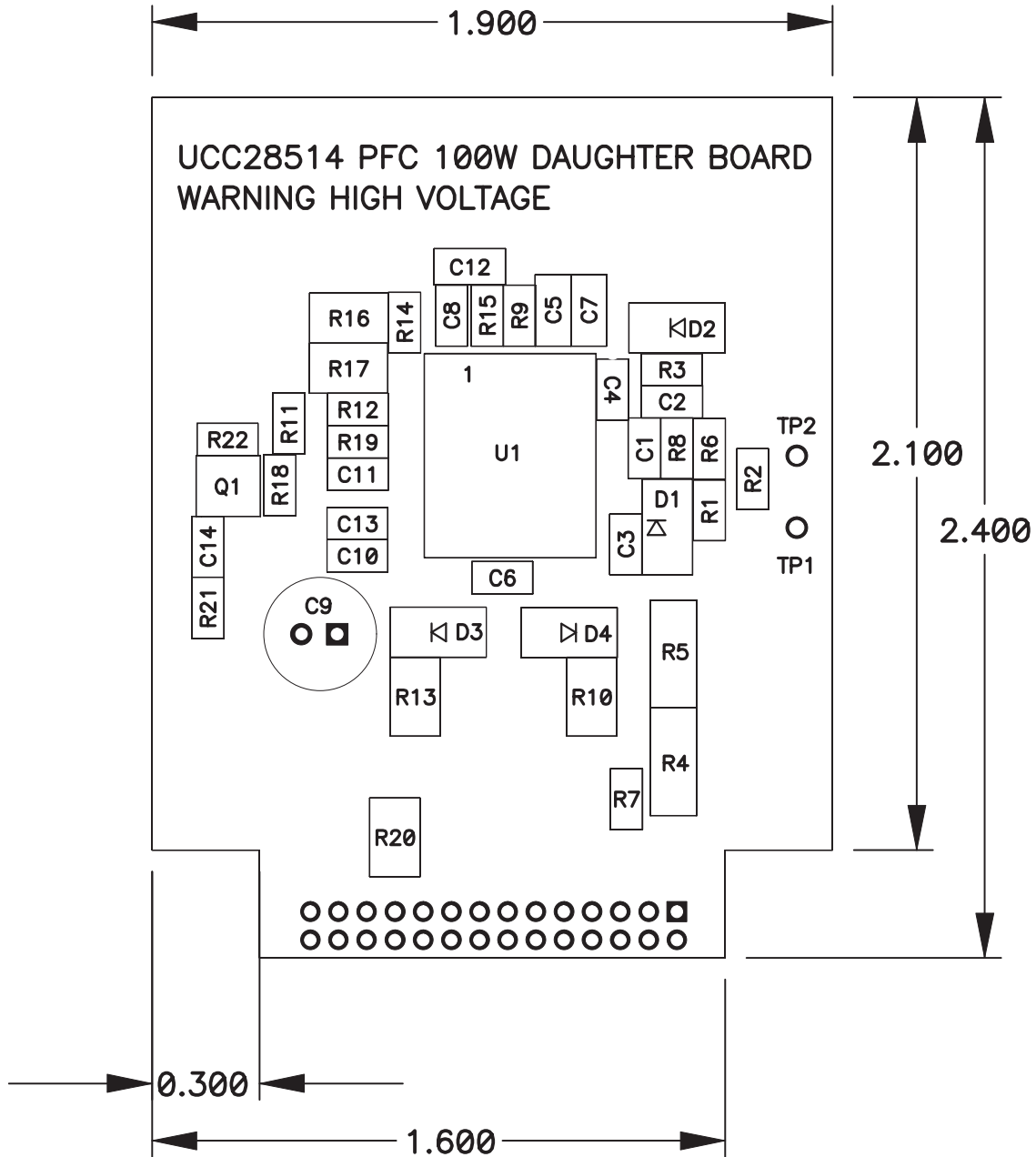

Figure 4. Mother Board HPA013



NOTE: R23 can be found on the back of the daughter board.

Figure 5. Daughter Board HPA020

6 Electrical Characteristics

	MIN	TYP	MAX	UNITS
V_{IN}	85		265	V_{RMS}
Output	23	24	25	V
P_{OUT}	10		100	W
Output Ripple A			500	mV

7 Reference Design Performance

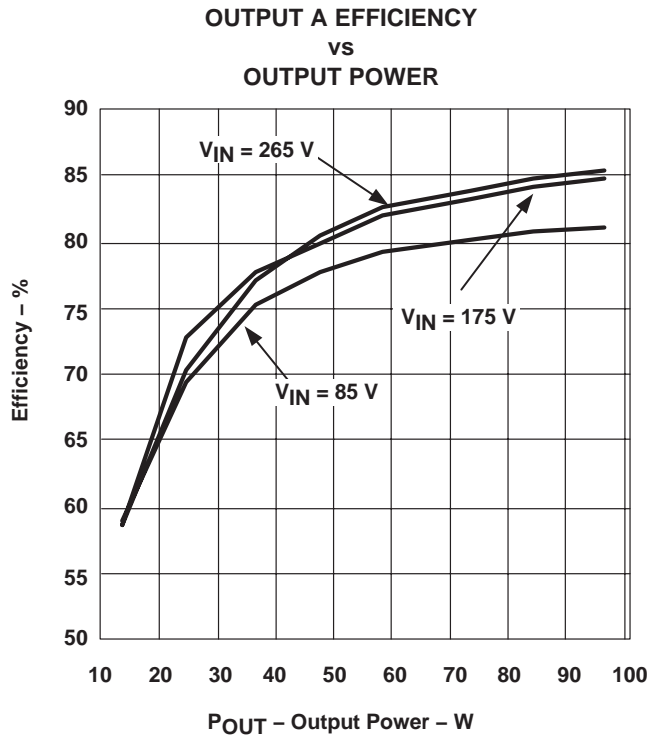

Figure 6

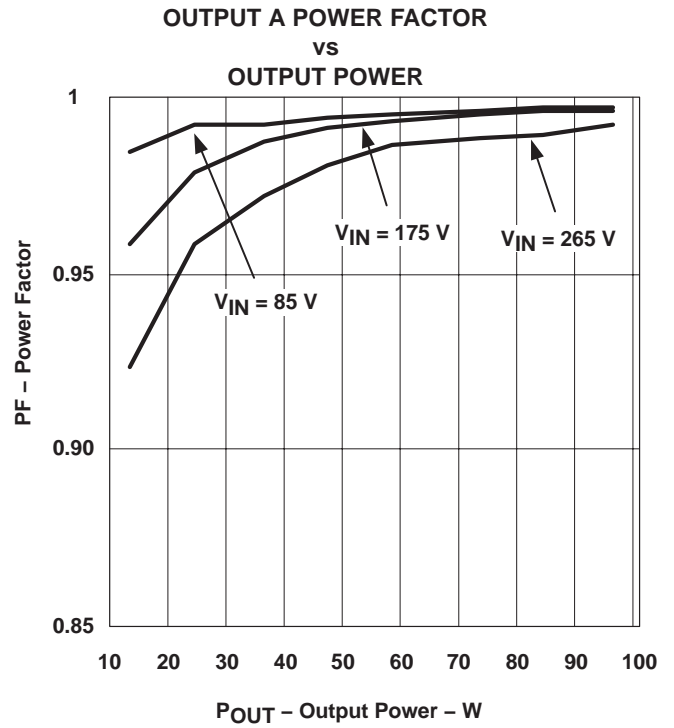

Figure 7

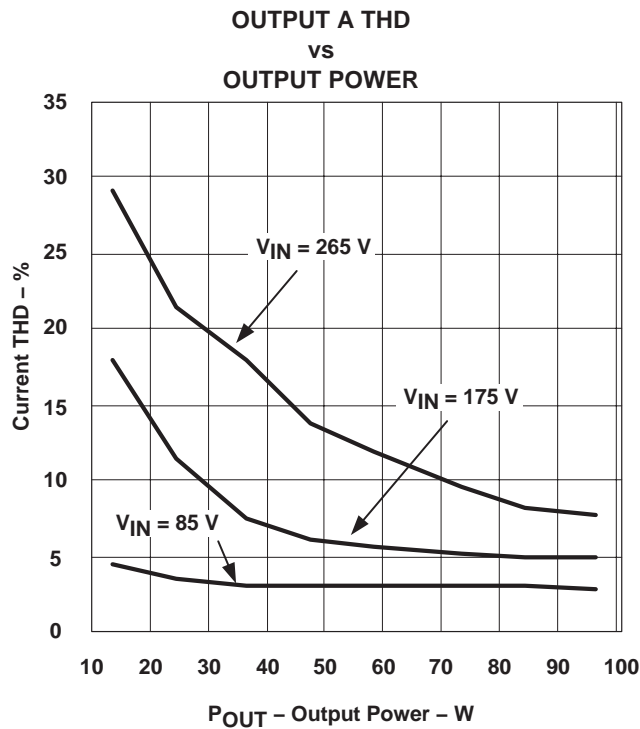

Figure 8

IMPORTANT NOTICE

Texas Instruments Incorporated and its subsidiaries (TI) reserve the right to make corrections, modifications, enhancements, improvements, and other changes to its products and services at any time and to discontinue any product or service without notice. Customers should obtain the latest relevant information before placing orders and should verify that such information is current and complete. All products are sold subject to TI's terms and conditions of sale supplied at the time of order acknowledgment.

TI warrants performance of its hardware products to the specifications applicable at the time of sale in accordance with TI's standard warranty. Testing and other quality control techniques are used to the extent TI deems necessary to support this warranty. Except where mandated by government requirements, testing of all parameters of each product is not necessarily performed.

TI assumes no liability for applications assistance or customer product design. Customers are responsible for their products and applications using TI components. To minimize the risks associated with customer products and applications, customers should provide adequate design and operating safeguards.

TI does not warrant or represent that any license, either express or implied, is granted under any TI patent right, copyright, mask work right, or other TI intellectual property right relating to any combination, machine, or process in which TI products or services are used. Information published by TI regarding third-party products or services does not constitute a license from TI to use such products or services or a warranty or endorsement thereof. Use of such information may require a license from a third party under the patents or other intellectual property of the third party, or a license from TI under the patents or other intellectual property of TI.

Reproduction of information in TI data books or data sheets is permissible only if reproduction is without alteration and is accompanied by all associated warranties, conditions, limitations, and notices. Reproduction of this information with alteration is an unfair and deceptive business practice. TI is not responsible or liable for such altered documentation.

Resale of TI products or services with statements different from or beyond the parameters stated by TI for that product or service voids all express and any implied warranties for the associated TI product or service and is an unfair and deceptive business practice. TI is not responsible or liable for any such statements.

Following are URLs where you can obtain information on other Texas Instruments products and application solutions:

Products		Applications	
Amplifiers	amplifier.ti.com	Audio	www.ti.com/audio
Data Converters	dataconverter.ti.com	Automotive	www.ti.com/automotive
DSP	dsp.ti.com	Broadband	www.ti.com/broadband
Interface	interface.ti.com	Digital Control	www.ti.com/digitalcontrol
Logic	logic.ti.com	Military	www.ti.com/military
Power Mgmt	power.ti.com	Optical Networking	www.ti.com/opticalnetwork
Microcontrollers	microcontroller.ti.com	Security	www.ti.com/security
		Telephony	www.ti.com/telephony
		Video & Imaging	www.ti.com/video
		Wireless	www.ti.com/wireless

Mailing Address: Texas Instruments
Post Office Box 655303 Dallas, Texas 75265



Компания «ЭлектроПласт» предлагает заключение долгосрочных отношений при поставках импортных электронных компонентов на взаимовыгодных условиях!

Наши преимущества:

- Оперативные поставки широкого спектра электронных компонентов отечественного и импортного производства напрямую от производителей и с крупнейших мировых складов;
- Поставка более 17-ти миллионов наименований электронных компонентов;
- Поставка сложных, дефицитных, либо снятых с производства позиций;
- Оперативные сроки поставки под заказ (от 5 рабочих дней);
- Экспресс доставка в любую точку России;
- Техническая поддержка проекта, помощь в подборе аналогов, поставка прототипов;
- Система менеджмента качества сертифицирована по Международному стандарту ISO 9001;
- Лицензия ФСБ на осуществление работ с использованием сведений, составляющих государственную тайну;
- Поставка специализированных компонентов (Xilinx, Altera, Analog Devices, Intersil, Interpoint, Microsemi, Aeroflex, Peregrine, Syfer, Eurofarad, Texas Instrument, Miteq, Cobham, E2V, MA-COM, Hittite, Mini-Circuits, General Dynamics и др.);

Помимо этого, одним из направлений компании «ЭлектроПласт» является направление «Источники питания». Мы предлагаем Вам помощь Конструкторского отдела:

- Подбор оптимального решения, техническое обоснование при выборе компонента;
- Подбор аналогов;
- Консультации по применению компонента;
- Поставка образцов и прототипов;
- Техническая поддержка проекта;
- Защита от снятия компонента с производства.



Как с нами связаться

Телефон: 8 (812) 309 58 32 (многоканальный)

Факс: 8 (812) 320-02-42

Электронная почта: org@eplast1.ru

Адрес: 198099, г. Санкт-Петербург, ул. Калинина, дом 2, корпус 4, литера А.