

μPG2250T5N-ZBT-EV-A

Evaluation Board

- Circuit Description
- Typical Performance Data
- Circuit Schematic and Assembly Drawing
- Appendix: Evaluation Board Document of the uPG2250T5N-EVAL-A

Circuit Description:

This evaluation board provides a quick and convenient means of evaluating the performance of the NEC uPG2250T5N power amplifier and two RF switches, uPG2214TB and uPG2179TB, for a “range extension” application at 2.4GHz ISM band (such as for Bluetooth or ZigBee applications). The circuit provides two paths for a transmit signal of a Bluetooth or Zigbee RF transceiver: either through the amplifier or direct pass through two switches. The functional diagram of this board is shown below:

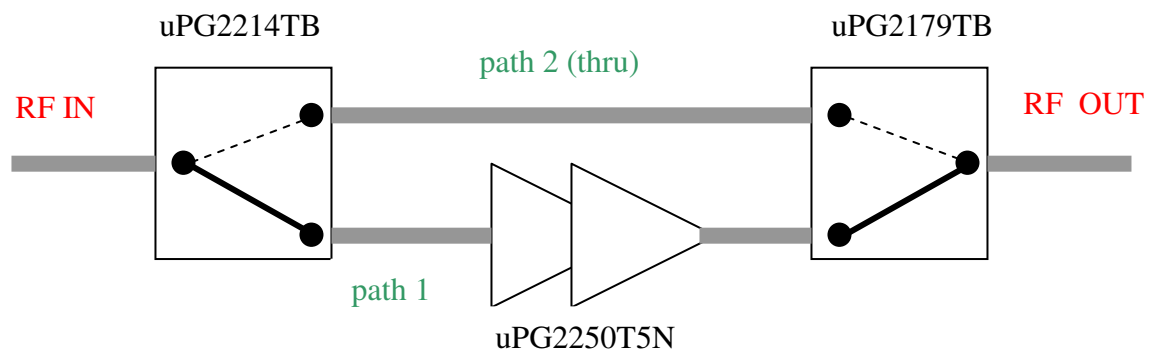

The two paths are selected by the logic levels at the two control pin-connectors, VA and VT, (refer to the schematic for the connector designation) according to the following truth table:

VA	VT	Path 1 (PA)	Path 2 (Thru)
0 V	3.0 V	OFF	ON
3.0 V	0 V	ON	OFF

The matching and bias circuits for the uPG2250T5N are based on those used in the CEL’s evaluation circuit board, uPG2250T5N-EVAL-A with some changes on a few component values to accommodate the difference in layout. For more information on the PA circuit design, refer to the Evaluation Board Document of uPG2250T5N-EVAL-A in the appendix.

The PCB is FR4 four layer board. The top and bottom dielectric layers are 8mils thick. The total board thickness is 62mils. The dielectric constant of FR4 is 4.3.

Typical Performance Data

Path 1:

Test conditions:

F=2.45GHz, Vdd=3V, Vcont=1.8V

The output power, Pout, supply current, Idd, and power added efficiency, PAE, as a function of input power, Pin, are shown in the following plot.

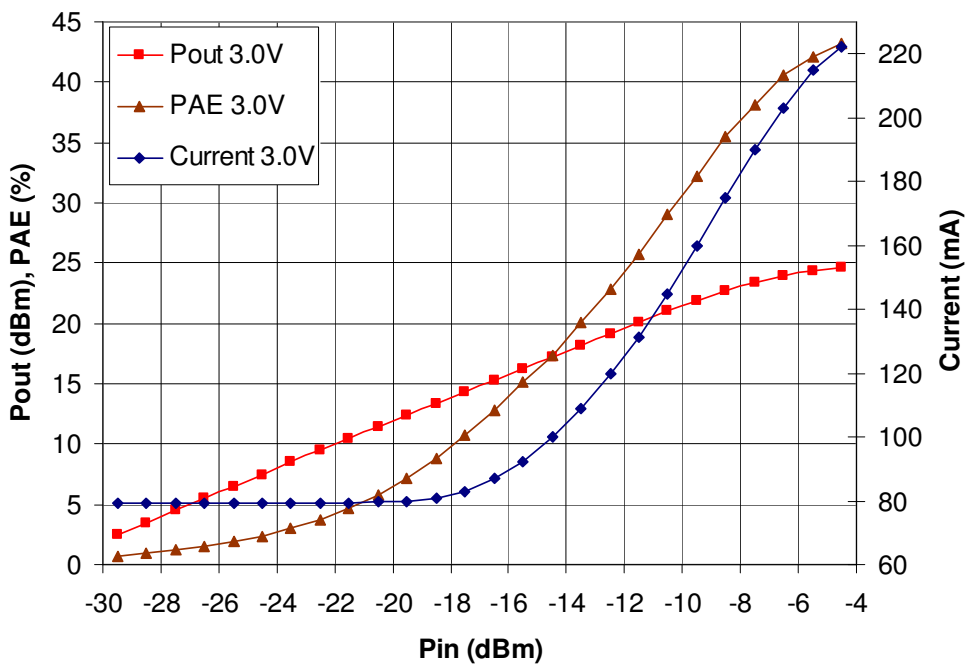

Path 2:

The insertion of the “thru” path is 1.2dB.

REVISIONS				
ZONE	LTR	DESCRIPTION	DATE	APPROVED

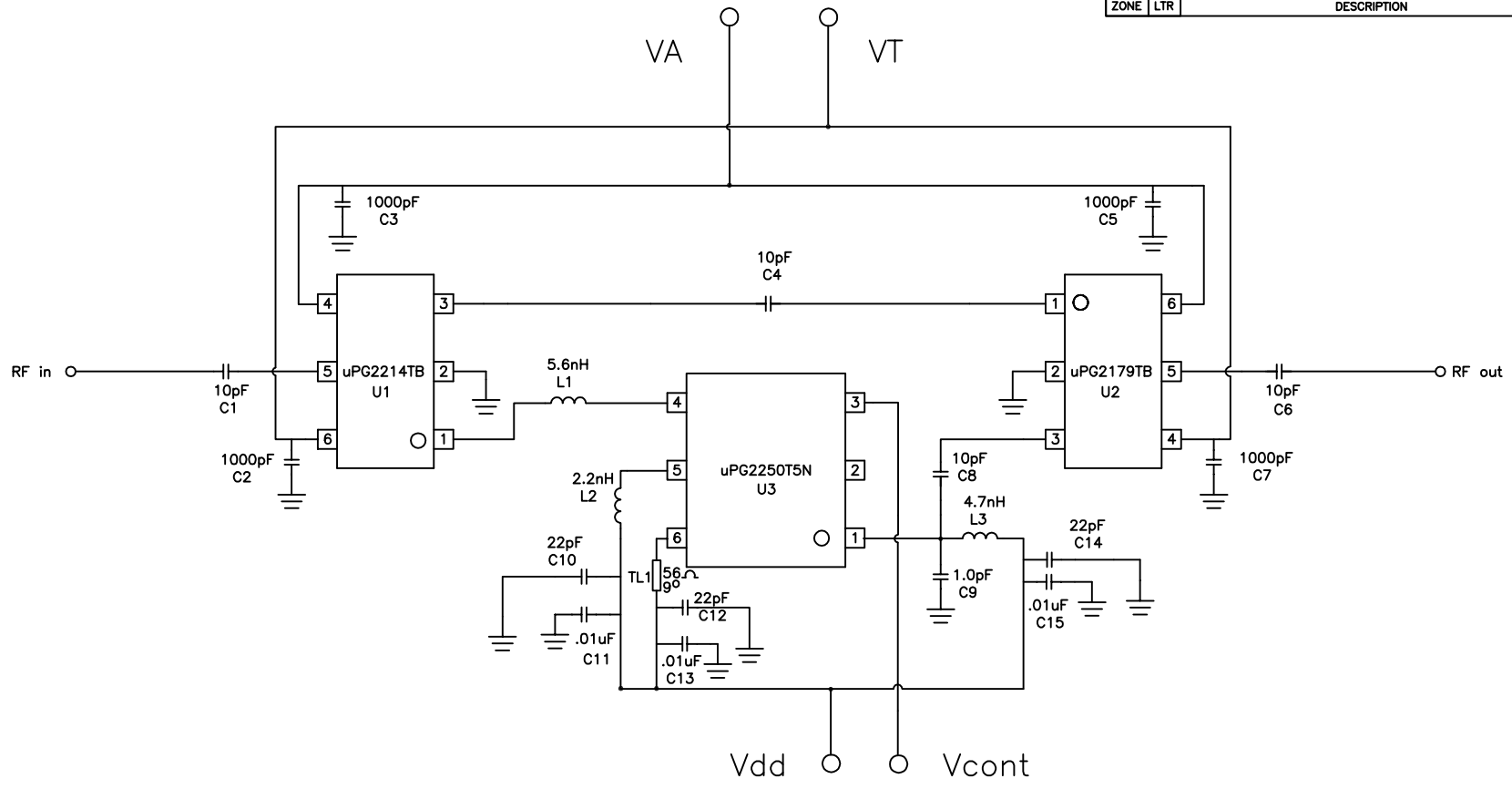

1	LQG15HS4N7S02	L3	0402 4.7nH IND MURATA	15
1	LQG15HS2N2S02	L2	0402 2.2nH IND MURATA	14
1	LQG15HS5N6S02	L1	0402 5.6nH IND MURATA	13
3	GRM155R71E103KA01D	C11,C13,C15	0402 0.01uF CAP MURATA	12
3	GRM1555C1H220JZ01D	C10,C12,C14	0402 22pF CAP MURATA	11
1	GRM1555C1H1R0CZ01D	C9	0402 1.0pF CAP MURATA	10
4	GRM1555C1H102JA01D	C2,C3,C5,C7	0402 1000pF CAP MURATA	9
4	GRM1555C1H100JZ01D	C1,C4,C6,C8	0402 10pF CAP MURATA	8
		TL1	56 Ω , 90° @2.45GHz	7
5	2340-6111 TG	P1,P2,P3,P4,P5	PIN HEADER 3M	7
2	142-0711-821	J1,J2	SMA FEMALE CONNECTOR E.F.JOHNSON	6
1	uPG2250T5N	U3	NEC GaAs MMIC Pwr Amplifier uPG2250T5N	5
1	uPG2179TB	U2	NEC GaAs SPDT Switch uPG2179TB	4
1	uPG2214TB	U1	NEC GaAs SPDT Switch uPG2214TB	3
1	CL-101939	DRAWING	COMPONENT LAYOUT DRAWING	2
1	N/A	PCB	PCB MANUFACTURED BY PCB NETWORKS	1
QTY	PART NUMBER OR IDENTIFYING NO.	NOMENCLATURE OR DESCRIPTION	MATERIAL/SPECIFICATION	ITEM NO.

PARTS LIST

APPROVALS	
Drawing by: BMU	06/07/2007
Designed by: BMU	06/07/2007
Checked by:	
Project Engineer:	
Quality Control:	

CALIFORNIA EASTERN LABS 4590 PATRICK HENRY DR. SANTA CLARA CA. 95054	TITLE:		UPG2250T5N-ZBT-EV-A SCHEMATIC_BOM
	SIZE	FSCM NO.	
C			AD-101939
SCALE	SCALE	RELEASE DATE	RELDATE
SHEET SHNO		OF NOSH	

REV

REVISIONS				
ZONE	LTR	DESCRIPTION	DATE	APPROVED

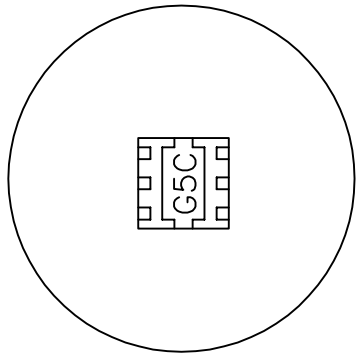
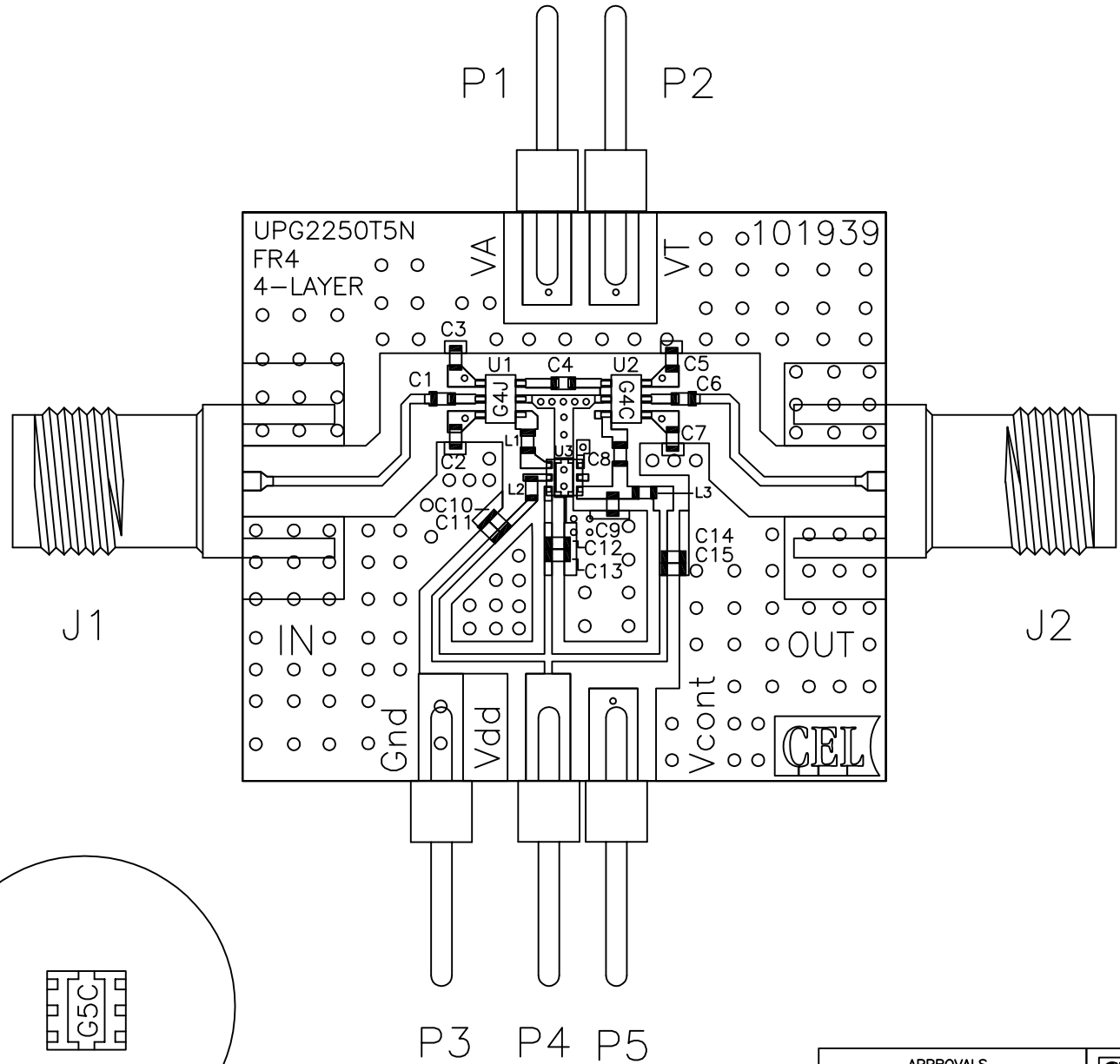

APPROVALS		 CALIFORNIA EASTERN LABS 4590 PATRICK HENRY DR. SANTA CLARA CA. 95054		
Drawing by: BMU	06/07/2007	TITLE: UPG2250T5N-ZBT-EV-A ASSEMBLY_DRAWING		
Designed by: BMU	06/07/2007			
Checked by:				
Project Engineer:		SIZE C	FSCM NO.	DWG NO. AD-101939
Quality Control:				REV -

μPG2250T5N-EVAL-A

Evaluation Board

- Circuit Description
- Performance data
- Circuit schematic and assembly drawing

Circuit Description

The circuit schematic and assembly drawing are shown on the last two pages.

Matching and Bias Circuits

The inductor L1 is for input matching and should be placed close to the device.

The output matching is realized mainly with the capacitor C6. C6 can be placed as close as possible to the device without much sacrifice of the performance when the layout space is tight. On the other hand the output power can be increased by a fraction of dB by moving C6 away from the device. The trace length between C6 and the device on this evaluation board is about 100 mil. Because of the gradual change in its width, the effect of this section of trace cannot be simply represented by a set of parameters of transmission line impedance and electrical length. It is recommended that the designer leave some space for tuning on this trace length in the initial prototype board layout if an optimal output power is desirable.

The uPG2250T5N has three gain stages, each being biased by an external voltage supply. The DC feed lines are not completely isolated from the RF path on the chip, and as a result care needs to be taken in the board layout for these DC lines.

The inductor L2 on the Vdd1 line provides the DC feed for the first stage and is part of the inter-stage matching between stage 1 and 2 as well. The value of this inductor may need to be adjusted on the application board to have the optimized performance. Generally it should be placed close to the device and immediately followed by the capacitor C2 as shown in the assembly drawing of this evalboard.

The length of trace TL1 on the Vdd2 line has significant impact on the output power and the value shown in the schematic should be used in the application board layout.

The inductor L3 is for the last stage DC feed and functions as an RF choke. Its value and location are not critical.

The three shunt capacitors on the DC lines (C2, C8 and C9) provide a low RF impedance at their respective locations. Their value should be in the range of 10 to 30pF. These low RF impedance spots adequately isolate the RF circuit from the rest of DC feed lines beyond the point of shunt capacitors. This arrangement is particularly beneficial in transferring the evaluation circuit to the end products because the RF characteristic of a DC feed line usually cannot be well controlled in a practical board design. The other three 0.01uF capacitors, C1, C3 and C5, are general bypass capacitors and the user can select their values and locations according the design requirements.

PCB Material

The PCB is Getek two layer board. The board thickness is 28mil.

Typical Performance Data

Test Conditions:

$f=2.45\text{GHz}$; $P_{in}=-5\text{dBm}$; $V_{cont}=1.8\text{V}$

For $V_{DD1,2,3}=1.8\text{V}$

Quiescent current I_{dsq} : 55mA;

Output Power P_{out} : 21dBm;

Supply Current I_{DD} : 130mA;

Efficiency PAE: 55%;

For $V_{DD1,2,3}=3\text{V}$

Quiescent current I_{dsq} : 80mA;

Output Power P_{out} : 25dBm;

Supply Current I_{DD} : 200mA;

Efficiency PAE: 55%;

P_{out} and PAE vs P_{in} are shown in the following plot.

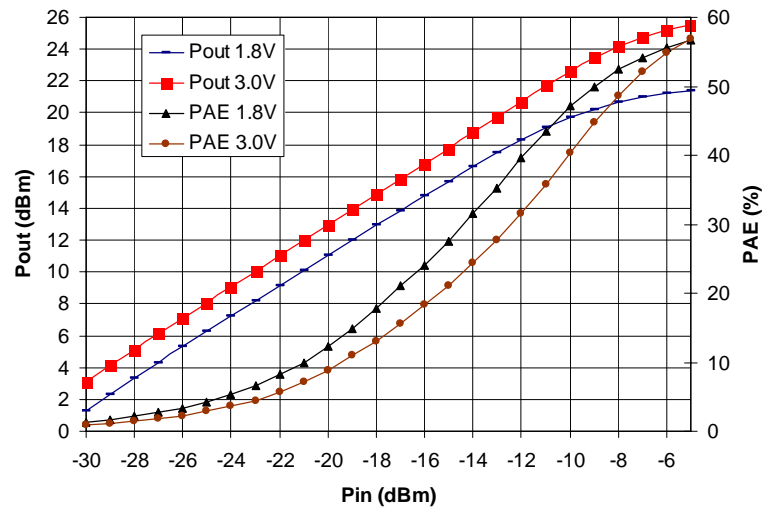

REVISIONS				
ZONE	LTR	DESCRIPTION	DATE	APPROVED

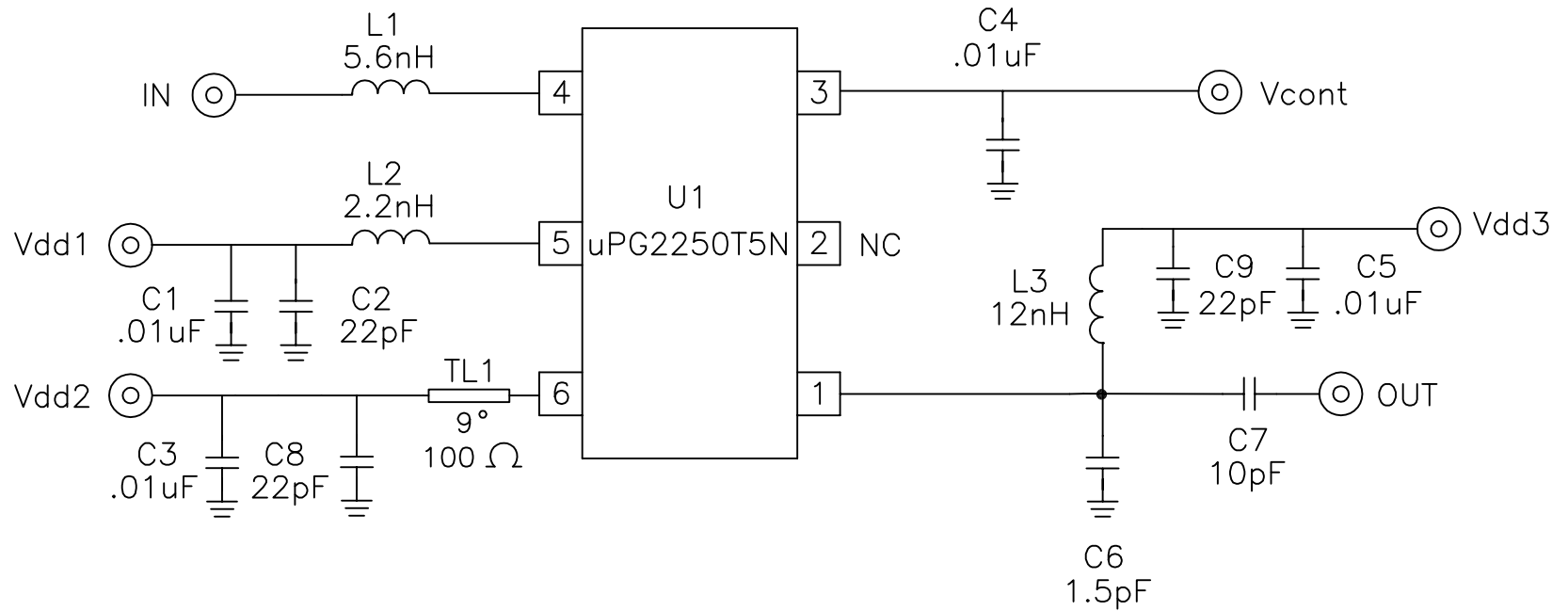

1	LQG15HS12NJ02	L3	0402 12nH IND MURATA	13
1	LQG15HS2N2S02	L2	0402 2.2nH IND MURATA	12
1	LQG15HS5N6S02	L1	0402 5.6nH IND MURATA	11
1	GRM1555C1H100JZ01B	C7	0402 10pF CAP MURATA	10
1	GRM1555C1H1R5CZ01D	C6	0402 1.5pF CAP MURATA	9
3	GRM1555C1H220JZ01B	C2,C8,C9	0402 22pF CAP MURATA	8
4	GRM155R71E103KA01D	C1,C3,C4,C5	0402 .01uF CAP MURATA	7
		TL1	100 Ohm, 9° @ 2.45GHz	6
5	2340-6111 TG	P1-P5	PIN HEADER 3M	5
2	142-0701-841	J1,J2	SMA FEMALE CONNECTOR E.F. JOHNSON	4
1	uPG2250T5N	U1	NEC uPG2250T5N	3
1	CL-101919	DRAWING	COMPONENT LAYOUT DRAWING	2
1	N/A	PCB	PCB MANUFACTURED BY NETWORK PCB	1
QTY	PART NUMBER OR IDENTIFYING NO.	NOMENCLATURE OR DESCRIPTION	MATERIAL/SPECIFICATION	ITEM NO.

PARTS LIST

APPROVALS		CEL CALIFORNIA EASTERN LABS 4590 PATRICK HENRY DR. SANTA CLARA CA. 95054			
Drawing by: BMU	01/03/2007	TITLE: UPG2250T5N-EVAL-A SCHEMATIC BOM			
Designed by: BMU	01/03/2007				
Checked by:					
Project Engineer:		SIZE C	FSCM NO.	DWG NO. AD-101919	REV
Quality Control:		SCALE	RELEASE DATE	RELDATE	SHEET SHNO OF NOSH

REVISIONS				
ZONE	LTR	DESCRIPTION	DATE	APPROVED

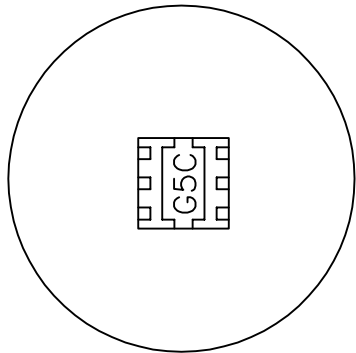
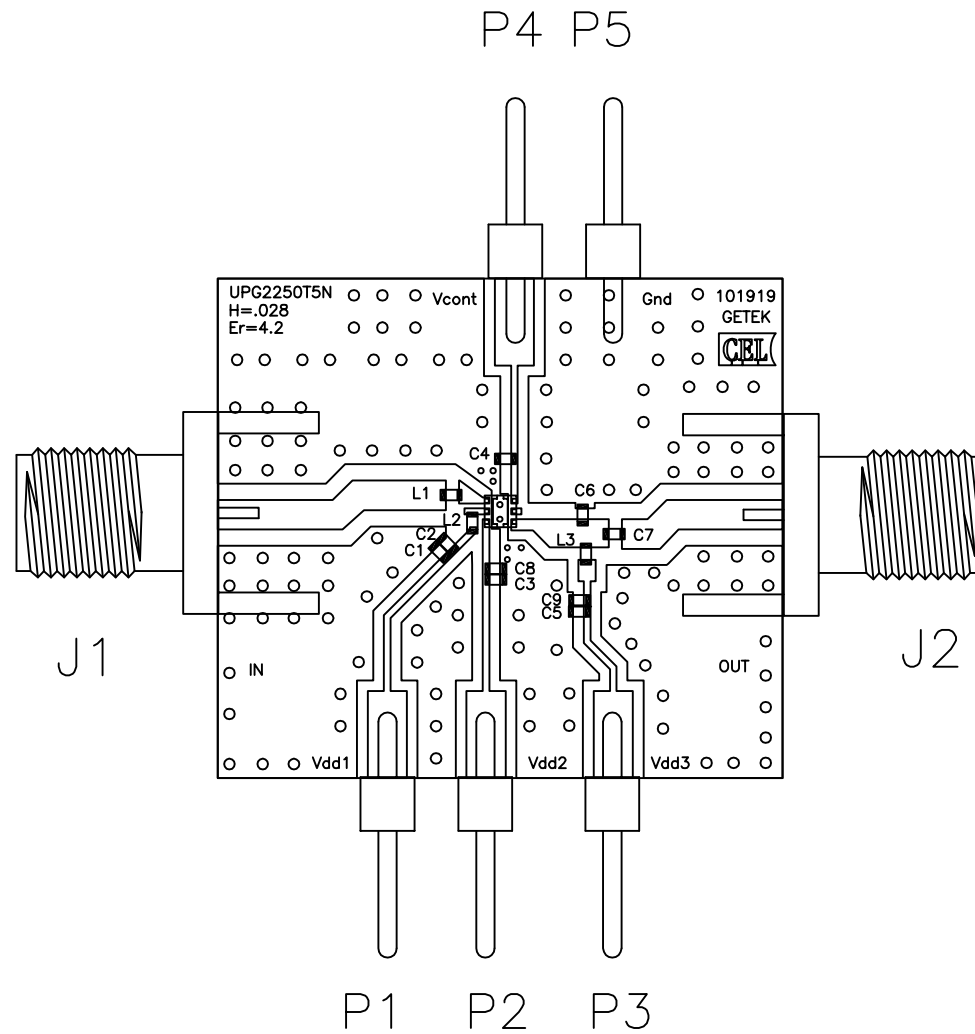

APPROVALS		CALIFORNIA EASTERN LABS 4590 PATRICK HENRY DR. SANTA CLARA CA. 95054		
Designed by:	BMU	01/03/2007	TITLE:	
Designed by:	BMU	01/03/2007	UPG2250T5N-EVAL-A	
Checked by:			ASSEMBLY_DRAWING	
Project Engineer:			SIZE	FSCM NO.
Quality Control:			C	DWG NO.
				AD-101919
				REV
				—



Компания «ЭлектроПласт» предлагает заключение долгосрочных отношений при поставках импортных электронных компонентов на взаимовыгодных условиях!

Наши преимущества:

- Оперативные поставки широкого спектра электронных компонентов отечественного и импортного производства напрямую от производителей и с крупнейших мировых складов;
- Поставка более 17-ти миллионов наименований электронных компонентов;
- Поставка сложных, дефицитных, либо снятых с производства позиций;
- Оперативные сроки поставки под заказ (от 5 рабочих дней);
- Экспресс доставка в любую точку России;
- Техническая поддержка проекта, помощь в подборе аналогов, поставка прототипов;
- Система менеджмента качества сертифицирована по Международному стандарту ISO 9001;
- Лицензия ФСБ на осуществление работ с использованием сведений, составляющих государственную тайну;
- Поставка специализированных компонентов (Xilinx, Altera, Analog Devices, Intersil, Interpoint, Microsemi, Aeroflex, Peregrine, Syfer, Eurofarad, Texas Instrument, Miteq, Cobham, E2V, MA-COM, Hittite, Mini-Circuits, General Dynamics и др.);

Помимо этого, одним из направлений компании «ЭлектроПласт» является направление «Источники питания». Мы предлагаем Вам помощь Конструкторского отдела:

- Подбор оптимального решения, техническое обоснование при выборе компонента;
- Подбор аналогов;
- Консультации по применению компонента;
- Поставка образцов и прототипов;
- Техническая поддержка проекта;
- Защита от снятия компонента с производства.



Как с нами связаться

Телефон: 8 (812) 309 58 32 (многоканальный)

Факс: 8 (812) 320-02-42

Электронная почта: org@eplast1.ru

Адрес: 198099, г. Санкт-Петербург, ул. Калинина, дом 2, корпус 4, литера А.