



The Future of Analog IC Technology®

MP1591

2A, 32V, 330KHz
Step-Down Converter

DESCRIPTION

The MP1591 is a high voltage step-down converter ideal for automotive power adapter battery chargers. Its wide 6.5V to 32V input voltage range covers the automotive battery's requirements and it achieves 2A continuous output for quick charge capability.

Current mode operation provides fast transient response and eases loop stabilization. Fault protection includes cycle-by-cycle current limiting and thermal shutdown. In shutdown mode, the converter draws only 20µA of supply current.

The MP1591 requires a minimum number of readily available external components to complete a 2A step-down DC to DC converter solution.

EVALUATION BOARD REFERENCE

Board Number	Dimensions
EV0020	2.1"X x 1.4"Y x 0.5"Z

FEATURES

- Wide 6.5V to 32V Input Operating Range
- 34V Absolute Maximum Input
- 2A Output Current
- 120mΩ Internal Power MOSFET Switch
- Stable with Low ESR Output Ceramic Capacitors
- Up to 95% Efficiency
- 20µA Shutdown Mode
- Fixed 330KHz Frequency
- Thermal Shutdown
- Cycle-by-Cycle Over Current Protection
- Output Adjustable From 1.23V to 21V
- Under Voltage Lockout
- Reference Voltage Output
- Available in 8-Pin SOIC Packages

APPLICATIONS

- Automotive Power Adapters
- PDA and Cellular Phone Battery Chargers
- Distributed Power Systems
- Automotive Aftermarket Electronics

"MPS" and "The Future of Analog IC Technology" are Registered Trademarks of Monolithic Power Systems, Inc.

TYPICAL APPLICATION

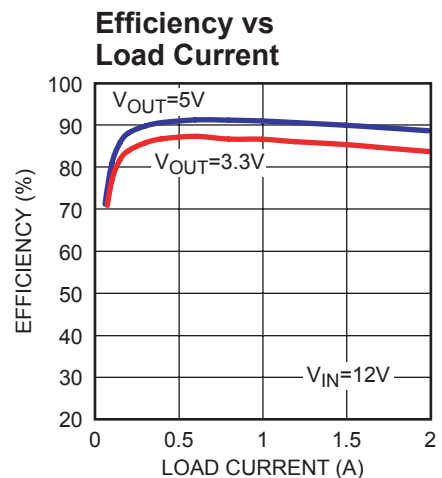
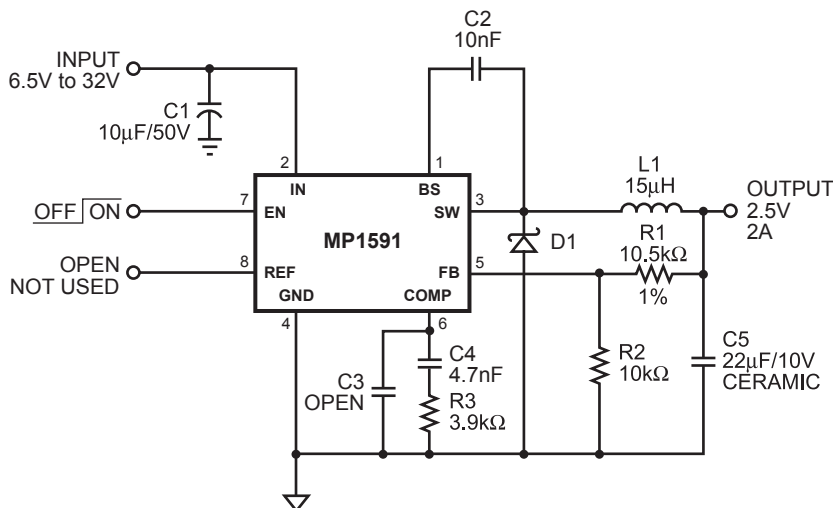

PACKAGE REFERENCE

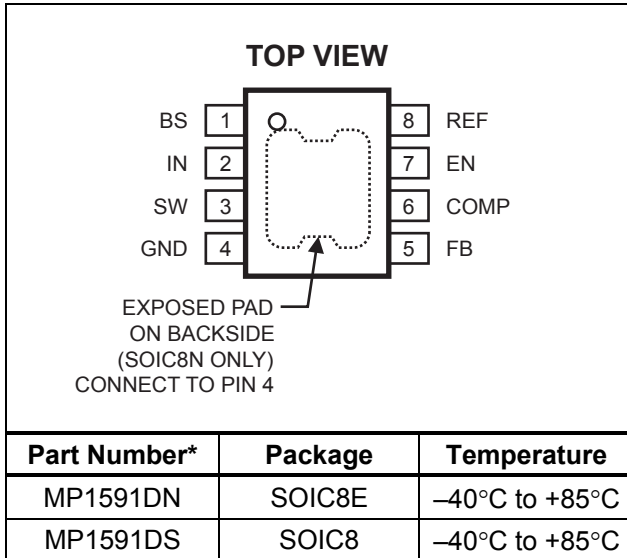

* For Tape & Reel, add suffix -Z (eg. MP1591DN-Z)
 For RoHS Compliant Packaging, add suffix -LF
 (eg. MP1591DN-LF-Z)

ABSOLUTE MAXIMUM RATINGS ⁽¹⁾

IN Supply Voltage -0.3V to +34V
 SW Voltage -1V to $V_{IN} + 0.3V$
 BS Voltage $V_{SW} - 0.3V$ to $V_{SW} + 6V$
 All Other Pins -0.3V to +6V
 Junction Temperature 150°C
 Lead Temperature 260°C
 Storage Temperature -65°C to +150°C

Recommended Operating Conditions ⁽²⁾

Input Voltage 6.5V to 32V
 Operating Temperature -40°C to +85°C

Thermal Resistance ⁽³⁾ θ_{JA} θ_{JC}

SOIC8 (w/ Exposed Pad) 50 10... °C/W
 SOIC8 90 45... °C/W

Notes:

- 1) Exceeding these ratings may damage the device.
- 2) The device is not guaranteed to function outside of its operating conditions.
- 3) Measured on approximately 1" square of 1 oz copper.

ELECTRICAL CHARACTERISTICS

$V_{IN} = 12V$, $T_A = +25^\circ C$, unless otherwise noted.

Parameter	Symbol	Condition	Min	Typ	Max	Units
Shutdown Supply Current		$V_{EN} = 0V$		20	35	μA
Supply Current		$V_{EN} = 5V$, $V_{FB} = 1.4V$		1.0	1.2	mA
Feedback Voltage		$6.5V \leq V_{IN} \leq 32V$, $V_{COMP} < 2V$	1.202	1.230	1.258	V
Error Amplifier Voltage Gain				400		V/V
Error Amplifier Transconductance		$\Delta I_C = \pm 10\mu A$	500	700	1100	$\mu A/V$
High-Side Switch On Resistance ⁽⁴⁾				120		m Ω
Low-Side Switch On Resistance ⁽⁴⁾				8.5		Ω
High-Side Switch Leakage Current		$V_{EN} = 0V$, $V_{SW} = 0V$		0	10	μA
Current Limit ⁽⁵⁾			2.5	3.6	4.9	A
Current Sense to COMP Transconductance				3.5		A/V
Oscillation Frequency			280	330	380	KHz
Short Circuit Oscillation Frequency		$V_{FB} = 0V$		35		KHz
Maximum Duty Cycle ⁽⁴⁾		$V_{FB} = 1.0V$		90		%
Minimum Duty Cycle ⁽⁴⁾		$V_{FB} = 1.5V$			0	%
EN Shutdown Threshold Voltage			0.8	1.2	1.6	V
Enable Pull-Up Current		$V_{EN} = 0V$		1.8		μA
EN UVLO Threshold		V_{EN} Rising	2.4	2.6	2.8	V
EN UVLO Threshold Hysteresis				250		mV

ELECTRICAL CHARACTERISTICS *(continued)*
 $V_{IN} = 12V$, $T_A = +25^{\circ}C$, unless otherwise noted.

Parameter	Symbol	Condition	Min	Typ	Max	Units
Thermal Shutdown ⁽⁴⁾				160		$^{\circ}C$
REF Voltage		$I_{REF} = 0$		5.0		V
REF Load Regulation ⁽⁴⁾		$\Delta I_{REF} = 0$ to 1mA		100		mV
REF Line Regulation ⁽⁴⁾		$I_{REF} = 100\mu A$, $V_{IN} = 6.5$ to 32V		30		mV

Notes:

4) These parameters are guaranteed by design, not production tested.

5) Equivalent output current = 1.5A \geq 50% Duty Cycle

2.0A \leq 50% Duty Cycle

Assumes ripple current = 30% of load current.

Slope compensation changes current limit.

PIN FUNCTIONS

Pin #	Name	Description
1	BS	High-Side Gate Drive Boost Input. BS supplies the drive for the high-side N-Channel MOSFET switch. Connect a 10nF or greater capacitor from SW to BS to power the high-side switch.
2	IN	Power Input. IN supplies the power to the IC, as well as the step-down converter switches. Drive IN with a 6.5V to 32V power source. Bypass IN to GND with a suitably large capacitor to eliminate noise on the input to the IC. See <i>Input Capacitor</i> .
3	SW	Power Switching Output. SW is the switching node that supplies power to the output. Connect the output LC filter from SW to the output load. Note that a capacitor is required from SW to BS to power the high-side switch.
4	GND	Ground. For the MP1591DN, connect the Exposed Pad to pin 4.
5	FB	Feedback Input. FB senses the output voltage to regulate that voltage. Drive FB with a resistive voltage divider from the output voltage. The feedback threshold is 1.230V. See <i>Setting the Output Voltage</i> .
6	COMP	Compensation Node. COMP is used to compensate the regulation control loop. Connect a series RC network from COMP to GND to compensate the regulation control loop. In some cases, an additional capacitor from COMP to GND is required. See <i>Compensation</i> .
7	EN	Enable/UVLO. A voltage greater than 2.8V enables operation. For complete low current shutdown the EN pin voltage needs to be less than 800mV.
8	REF	Reference Output. REF is the 5V reference voltage output. It can supply up to 1mA to external circuitry. If used, bypass REF to GND with 10nF or greater capacitor. Leave REF unconnected if not used.

OPERATION

The MP1591 is a current mode step-down regulator. It regulates input voltages from 6.5V to 32V down to an output voltage as low as 1.230V and is able to supply up to 2A of load current.

The MP1591 uses current-mode control to regulate the output voltage. The output voltage is measured at FB through a resistive voltage divider and amplified through the internal error amplifier. The output current of the transconductance error amplifier is presented at COMP where a network compensates the regulation control system.

The voltage at COMP is compared to the switch current measured internally to control the output voltage. The converter uses an internal N-Channel MOSFET switch to step-down the input voltage to the regulated output voltage. Since the MOSFET requires a gate voltage greater than the input voltage, a boost capacitor connected between SW and BS drives the gate. The capacitor is internally charged while SW is low. An internal 10Ω switch from SW to GND is used to insure that SW is pulled to GND when the switch is off to fully charge the BS capacitor

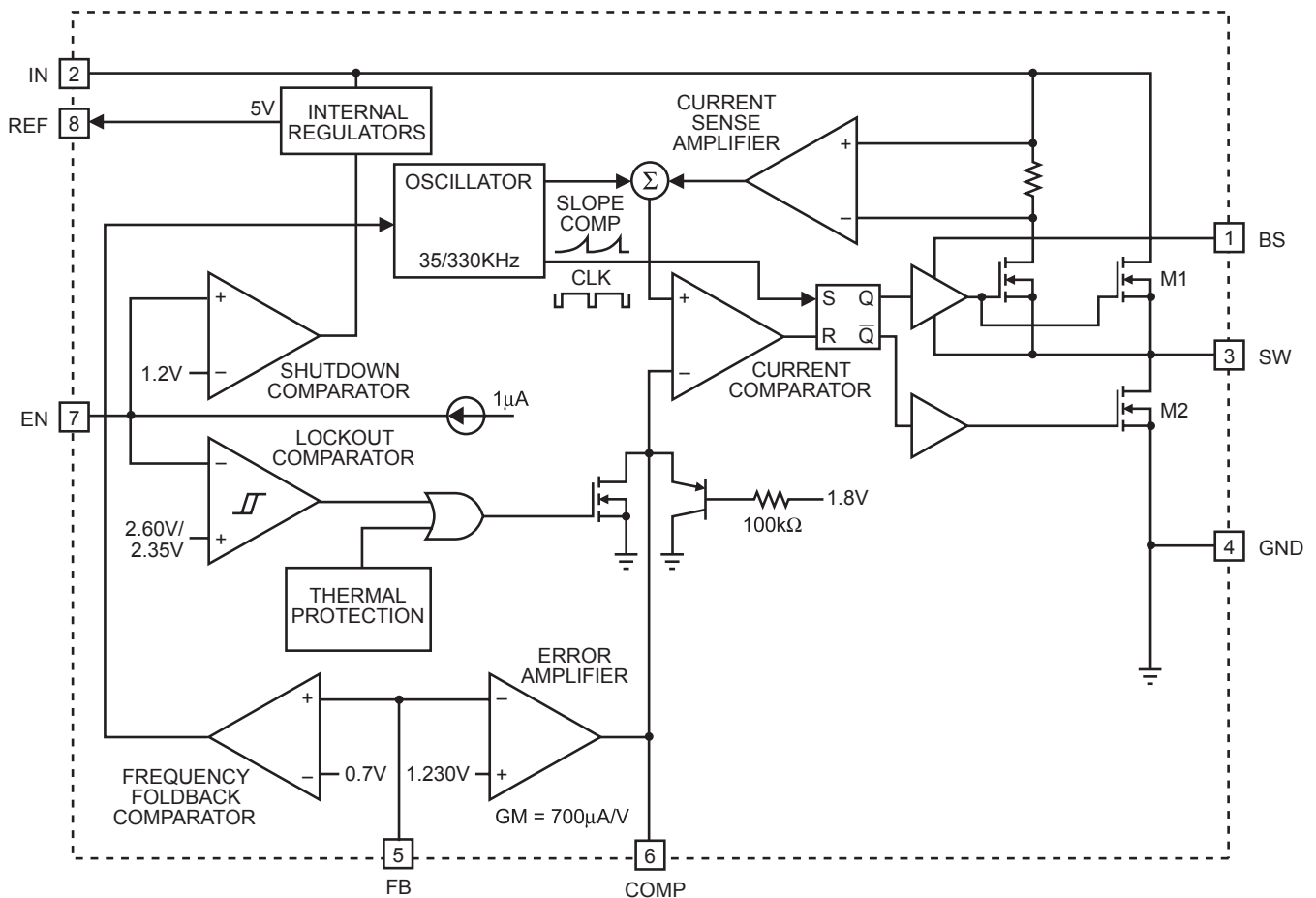

Figure 1—Functional Block Diagram

APPLICATION INFORMATION

COMPONENT SELECTION

Setting the Output Voltage

The output voltage is set using a resistive voltage divider from the output voltage to FB. The voltage divider divides the output voltage down by the ratio:

$$V_{FB} = V_{OUT} \times \frac{R2}{(R1 + R2)}$$

Where V_{FB} is the feedback voltage and V_{OUT} is the output voltage.

Thus the output voltage is:

$$V_{OUT} = 1.230 \times \frac{(R1 + R2)}{R2}$$

A typical value for R2 can be as high as 100k Ω , but 10k Ω is recommended. Using that value, R1 is determined by:

$$R1 \cong 8.18 \times (V_{OUT} - 1.230)$$

For example, for a 3.3V output voltage, R2 is 10k Ω , and R1 is 17k Ω .

Inductor (L1)

The inductor is required to supply constant current to the output load while being driven by the switched input voltage. A larger value inductor results in less ripple current that results in lower output ripple voltage. However, the larger value inductor has a larger physical size, higher series resistance, and/or lower saturation current. Choose an inductor that does not saturate under the worst-case load conditions. A good rule to use for determining the inductance is to allow the peak-to-peak ripple current in the inductor to be approximately 30% of the maximum load current that the IC can provide. Also, make sure that the peak inductor current (the load current plus half the peak-to-peak inductor ripple current) is below the 2.3A minimum current limit.

The inductance value can be calculated by the equation:

$$L1 = V_{OUT} \times \frac{(V_{IN} - V_{OUT})}{(V_{IN} \times f \times \Delta I)}$$

Where V_{IN} is the input voltage, f is the switching frequency and ΔI is the peak-to-peak inductor ripple current.

Table 1 lists a number of suitable inductors from various manufacturers.

Table 1—Inductor Selection Guide

Vendor/ Model	Core Type	Core Material	Package Dimensions (mm)		
			W	L	H
Sumida					
CR75	Open	Ferrite	7.0	7.8	5.5
CDH74	Open	Ferrite	7.3	8.0	5.2
CDRH5D28	Shielded	Ferrite	5.5	5.7	5.5
CDRH5D28	Shielded	Ferrite	5.5	5.7	5.5
CDRH6D28	Shielded	Ferrite	6.7	6.7	3.0
CDRH104R	Shielded	Ferrite	10.1	10.0	3.0
Toko					
D53LC Type A	Shielded	Ferrite	5.0	5.0	3.0
D75C	Shielded	Ferrite	7.6	7.6	5.1
D104C	Shielded	Ferrite	10.0	10.0	4.3
D10FL	Open	Ferrite	9.7	1.5	4.0
Coilcraft					
DO3308	Open	Ferrite	9.4	13.0	3.0
DO3316	Open	Ferrite	9.4	13.0	5.1

Input Capacitor (C1)

The input current to the step-down converter is discontinuous, and so a capacitor is required to supply the AC current to the step-down converter while maintaining the DC input voltage. A low ESR capacitor is required to keep the noise at the IC to a minimum. Ceramic capacitors are preferred, but tantalum or low ESR electrolytic capacitors may also suffice.

The input capacitor value should be greater than 10µF. The capacitor can be electrolytic, tantalum or ceramic. However, since it absorbs the input switching current it requires an adequate ripple current rating. Its RMS current rating should be greater than approximately 1/2 of the DC load current.

For insuring stable operation C1 should be placed as close to the IC as possible. Alternately, a smaller high quality ceramic 0.1µF capacitor may be placed closer to the IC and a larger capacitor placed farther away. If using this technique, it is recommended that the larger capacitor be a tantalum or electrolytic type. All ceramic capacitors should be placed close to the MP1591.

Output Capacitor (C5)

The output capacitor is required to maintain the DC output voltage. Low ESR capacitors are preferred to keep the output voltage ripple low. The characteristics of the output capacitor also affect the stability of the regulation control system. Ceramic, tantalum or low ESR electrolytic capacitors are recommended. In the case of ceramic capacitors, the impedance at the switching frequency is dominated by the capacitance, and so the output voltage ripple is mostly independent of the ESR. The output voltage ripple is estimated to be:

$$V_{\text{RIPPLE}} \cong 1.4 \times V_{\text{IN}} \times \left(\frac{f_{\text{LC}}}{f_{\text{SW}}} \right)^2$$

Where V_{RIPPLE} is the output ripple voltage, f_{LC} is the resonant frequency of the LC filter, f_{SW} is the switching frequency.

In the case of tantalum or low-ESR electrolytic capacitors, the ESR dominates the impedance at the switching frequency, and so the output ripple is calculated as:

$$V_{\text{RIPPLE}} \cong \Delta I \times R_{\text{ESR}}$$

Where V_{RIPPLE} is the output voltage ripple and R_{ESR} is the equivalent series resistance of the output capacitors.

Output Rectifier Diode (D1)

The output rectifier diode supplies the current to the inductor when the high-side switch is off. To reduce losses due to the diode forward voltage and recovery times, use a Schottky rectifier.

Table 2 provides some recommended Schottky rectifiers based on the maximum input voltage and current rating.

Table 2—Diode Selection Guide

V _{IN} (Max)	2A Load Current		3A Load Current	
	Part Number	Vendor	Part Number	Vendor
15V	30BQ15	4		
20V	B220	1	B320	1
	SK23	6	SK33	1, 6
	SR22	6	SS32	3
30V	20BQ030	4	B330	1
	B230	1	B340L	1
	SK23	6	MBRD330	4, 5
	SR23	3, 6	SK33	1, 6
34V	SS23	2, 3	SS33	2, 3
	21DQ04	4	B340L	1
	MBRS240L	5	MBRS340	4
	SK24	6	SK34	1, 6
	SS24	2, 3	SS34	2, 3

Table 3 lists manufacturer's websites.

Table 3—Schottky Diode Manufacturers

#	Vendor	Web Site
1	Diodes, Inc.	www.diodes.com
2	Fairchild Semiconductor	www.fairchildsemi.com
3	General Semiconductor	www.gensemi.com
4	International Rectifier	www.irf.com
5	On Semiconductor	www.onsemi.com
6	Pan Jit International	www.panjit.com.tw

Choose a rectifier whose maximum reverse voltage rating is greater than the maximum input voltage, and whose current rating is greater than the maximum load current.

Compensation

The system stability is controlled through the COMP pin. COMP is the output of the internal transconductance error amplifier. A series capacitor-resistor combination sets a pole-zero combination to control the characteristics of the control system. The DC loop gain is:

$$A_{VDC} = \frac{V_{REF}}{V_{OUT}} \times A_{VEA} \times G_{CS} \times R_{LOAD}$$

Where V_{REF} is the feedback threshold voltage, 1.230V, A_{VEA} is the transconductance error amplifier voltage gain, 400 V/V, and G_{CS} is the current sense gain (roughly the output current divided by the voltage at COMP), 3.5 A/V.

The system has 2 poles of importance; one is due to the compensation capacitor (C4) and the other is due to the output capacitor (C5). These are:

$$f_{P1} = \frac{G_{MEA}}{(2\pi \times A_{VEA} \times C4)}$$

Where f_{P1} is the first pole, and G_{MEA} is the error amplifier transconductance (770 μ S) and

$$f_{P2} = \frac{1}{(2\pi \times R_{LOAD} \times C5)}$$

The system has one zero of importance due to the compensation capacitor (C4) and the compensation resistor (R3) which is

$$f_{Z1} = \frac{1}{(2\pi \times R3 \times C4)}$$

If large value capacitors with relatively high equivalent-series-resistance (ESR) are used, the zero due to the capacitance and ESR of the output capacitor can be compensated by a third pole set by R3 and C3

$$f_{P3} = \frac{1}{(2\pi \times R3 \times C3)}$$

The system crossover frequency f_c , (the frequency where the loop gain drops to 1, or 0dB) is important. A good rule of thumb is to set the crossover frequency to approximately one tenth of the switching frequency. In this case, the switching frequency is 330KHz, so use a crossover frequency of 33KHz. Lower crossover frequencies result in slower response and worse transient load recovery. Higher crossover frequencies can result in instability.

Choosing the Compensation Components

The values of the compensation components given in Table 4 yield a stable control loop for the output voltage and given capacitor.

Table 4—Compensation Values for Typical Output Voltage/Capacitor Combinations

V _{OUT}	C5	R3	C3	C4
2.5V	22 μ F Ceramic	3.9k Ω	None	4.7nF
3.3V	22 μ F Ceramic	5.1k Ω	None	3.9nF
5V	22 μ F Ceramic	7.5k Ω	None	2.7nF
12V	22 μ F Ceramic	18k Ω	None	1.2nF
2.5V	47 μ F SP-Cap	8.2k Ω	None	2.2nF
3.3V	47 μ F SP-Cap	10k Ω	None	2.2nF
5V	47 μ F SP-Cap	16k Ω	None	1.5nF
12V	47 μ F SP-Cap	36k Ω	None	1nF
2.5V	560 μ F/6.3V, AL 30m Ω ESR	100k Ω	150pF	1nF
3.3V	560 μ F/6.3V, AL 30m Ω ESR	120k Ω	120pF	1nF
5V	470 μ F/10V, AL 30m Ω ESR	150k Ω	82pF	1nF
12V	220 μ F/25V, AL 30m Ω ESR	180k Ω	33pF	1nF

Note: "AL" = Electrolytic

To optimize the compensation components that are not listed in Table 4, use the following procedure.

Choose the compensation resistor to set the desired crossover frequency. Determine the value by the following equation:

$$R3 = \frac{2\pi \times C5 \times V_{OUT} \times f_C}{G_{EA} \times G_{CS} \times V_{REF}}$$

Putting in the know constants and setting the crossover frequency to the desired 33KHz:

$$R3 \cong 6.88 \times 10^7 \times C5 \times V_{OUT}$$

Choose the compensation capacitor to set the zero below one fourth of the crossover frequency. Determine the value by the following equation:

$$C4 > \frac{2}{\pi \times R3 \times f_C} \approx \frac{1.93 \times 10^{-5}}{R3}$$

Determine if the second compensation capacitor, C3, is required. It is required if the ESR zero of the output capacitor occurs at less than four times the crossover frequency, or

$$8\pi \times C5 \times R_{ESR} \times f_C \geq 1$$

If this is the case, then add the second compensation resistor. Determine the value by the equation:

$$C3 = \frac{C5 \times R_{ESR(MAX)}}{R3}$$

Where $R_{ESR(MAX)}$ is the maximum ESR of the output capacitor.

Example:

$$V_{OUT} = 5V, C5 = 22\mu F \text{ Ceramic (ESR} = 10m\Omega)$$

$$R3 \approx 6.88 \times 10^7 (22 \times 10^{-6}) (5) = 7568\Omega$$

Use the nearest standard value of 7.5kΩ.

$$C4 > 1.93 \times 10^{-5} / 7.5K = 2.57nF$$

Use standard value of 2.7nF.

$8\pi \times C5 \times R_{ESR} \times f_C = 0.22$, which is less than 1. Therefore, no second compensation capacitor (C3) is required.

External Bootstrap Diode

It is recommended that an external bootstrap diode be added when the system has a 5V fixed input or the power supply generates a 5V output. This helps improve the efficiency of the regulator. The bootstrap diode can be a low cost one such as IN4148 or BAT54.

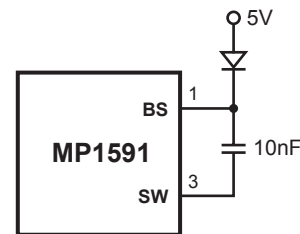

Figure 2—External Bootstrap Diode

This diode is also recommended for high duty cycle operation (when $\frac{V_{OUT}}{V_{IN}} > 65\%$) and high output voltage ($V_{OUT} > 12V$) applications.

TYPICAL APPLICATION CIRCUITS

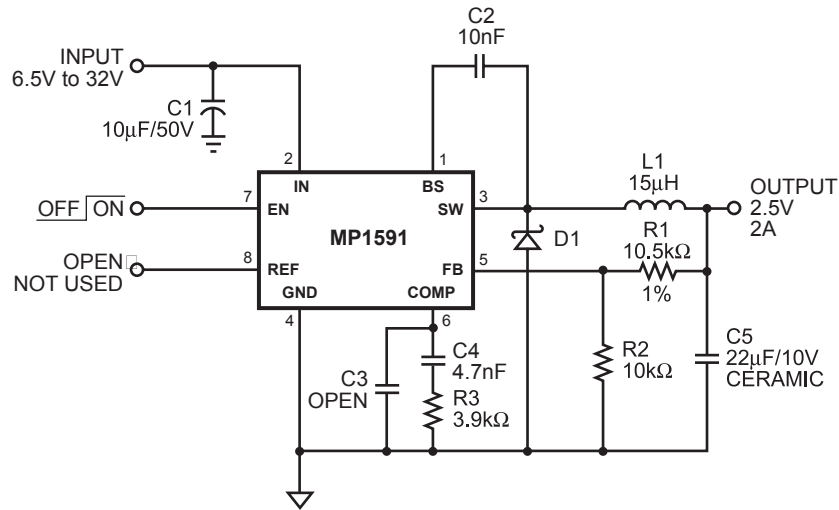

Figure 3—MP1591 with Murata 22µF / 10V Ceramic Output Capacitor

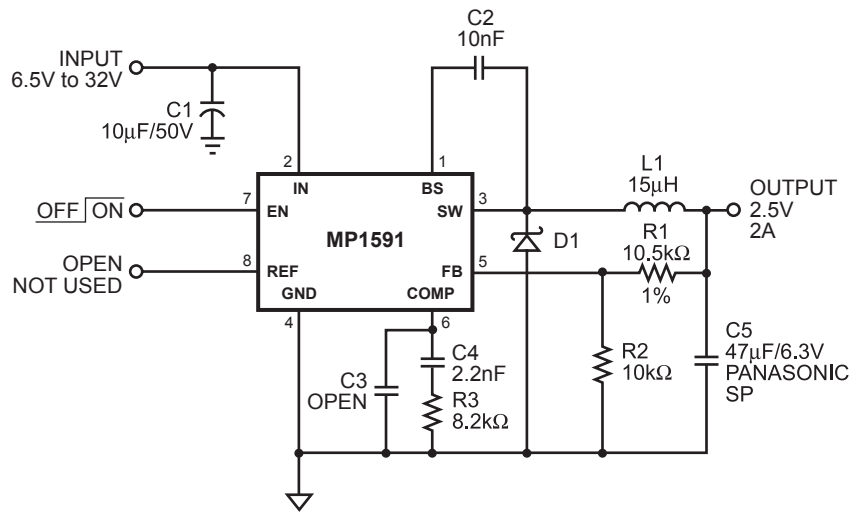
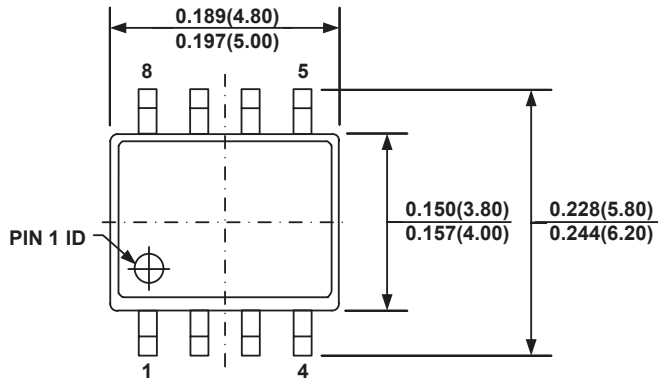

Figure 4—MP1591 with Panasonic 47µF / 6.3V Special Polymer Output Capacitor

PACKAGE INFORMATION

SOIC8



TOP VIEW

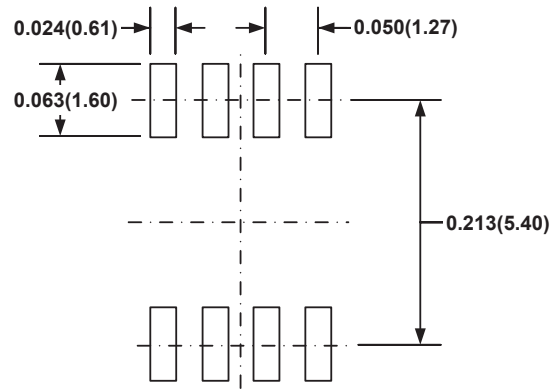

RECOMMENDED LAND PATTERN

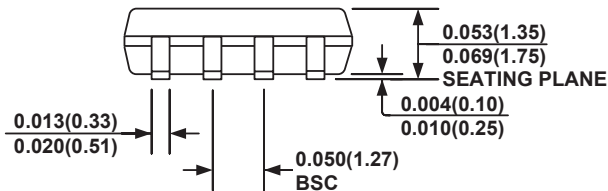

FRONT VIEW

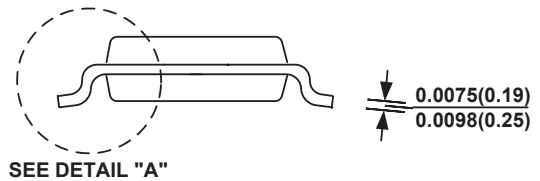

SIDE VIEW

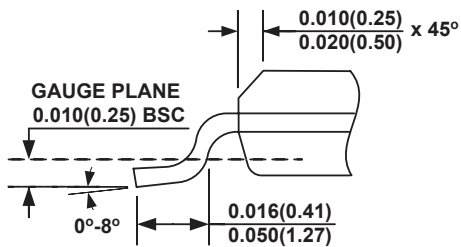

DETAIL "A"

NOTE:

- 1) CONTROL DIMENSION IS IN INCHES. DIMENSION IN BRACKET IS IN MILLIMETERS.
- 2) PACKAGE LENGTH DOES NOT INCLUDE MOLD FLASH, PROTRUSIONS OR GATE BURRS.
- 3) PACKAGE WIDTH DOES NOT INCLUDE INTERLEAD FLASH OR PROTRUSIONS.
- 4) LEAD COPLANARITY (BOTTOM OF LEADS AFTER FORMING) SHALL BE 0.004" INCHES MAX.
- 5) DRAWING CONFORMS TO JEDEC MS-012, VARIATION AA.
- 6) DRAWING IS NOT TO SCALE.

SOIC8E (WITH EXPOSED PAD)

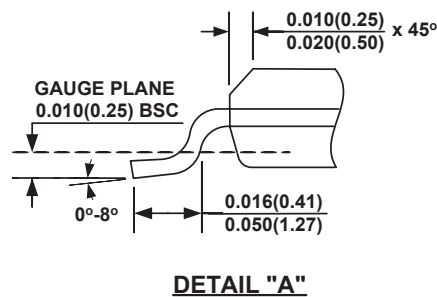
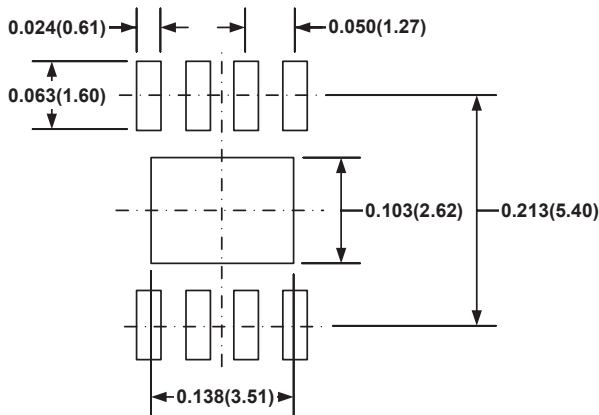
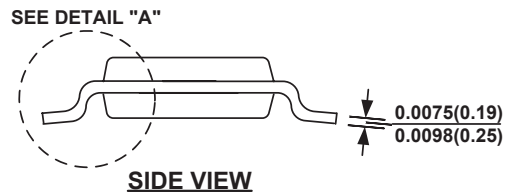
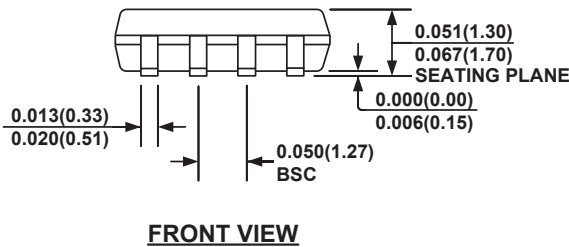
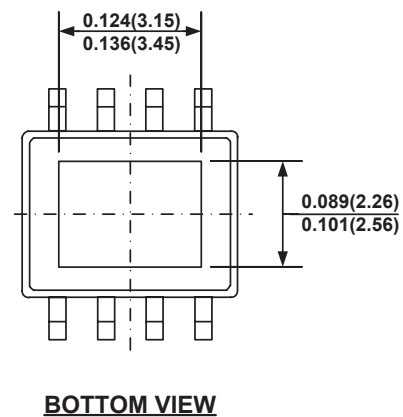
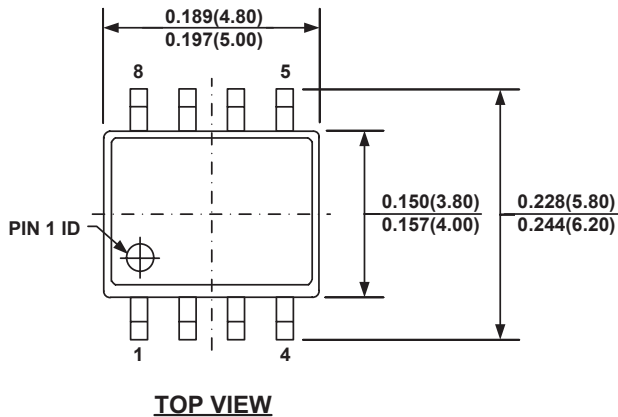

NOTE:

- 1) CONTROL DIMENSION IS IN INCHES. DIMENSION IN BRACKET IS IN MILLIMETERS.
- 2) PACKAGE LENGTH DOES NOT INCLUDE MOLD FLASH, PROTRUSIONS OR GATE BURRS.
- 3) PACKAGE WIDTH DOES NOT INCLUDE INTERLEAD FLASH OR PROTRUSIONS.
- 4) LEAD COPLANARITY (BOTTOM OF LEADS AFTER FORMING) SHALL BE 0.004" INCHES MAX.
- 5) DRAWING CONFORMS TO JEDEC MS-012, VARIATION BA.
- 6) DRAWING IS NOT TO SCALE.

NOTICE: The information in this document is subject to change without notice. Users should warrant and guarantee that third party Intellectual Property rights are not infringed upon when integrating MPS products into any application. MPS will not assume any legal responsibility for any said applications.



Компания «ЭлектроПласт» предлагает заключение долгосрочных отношений при поставках импортных электронных компонентов на взаимовыгодных условиях!

Наши преимущества:

- Оперативные поставки широкого спектра электронных компонентов отечественного и импортного производства напрямую от производителей и с крупнейших мировых складов;
- Поставка более 17-ти миллионов наименований электронных компонентов;
- Поставка сложных, дефицитных, либо снятых с производства позиций;
- Оперативные сроки поставки под заказ (от 5 рабочих дней);
- Экспресс доставка в любую точку России;
- Техническая поддержка проекта, помощь в подборе аналогов, поставка прототипов;
- Система менеджмента качества сертифицирована по Международному стандарту ISO 9001;
- Лицензия ФСБ на осуществление работ с использованием сведений, составляющих государственную тайну;
- Поставка специализированных компонентов (Xilinx, Altera, Analog Devices, Intersil, Interpoint, Microsemi, Aeroflex, Peregrine, Syfer, Eurofarad, Texas Instrument, Miteq, Cobham, E2V, MA-COM, Hittite, Mini-Circuits, General Dynamics и др.);

Помимо этого, одним из направлений компании «ЭлектроПласт» является направление «Источники питания». Мы предлагаем Вам помощь Конструкторского отдела:

- Подбор оптимального решения, техническое обоснование при выборе компонента;
- Подбор аналогов;
- Консультации по применению компонента;
- Поставка образцов и прототипов;
- Техническая поддержка проекта;
- Защита от снятия компонента с производства.



Как с нами связаться

Телефон: 8 (812) 309 58 32 (многоканальный)

Факс: 8 (812) 320-02-42

Электронная почта: org@eplast1.ru

Адрес: 198099, г. Санкт-Петербург, ул. Калинина, дом 2, корпус 4, литера А.