



LIGHTING FOREVER

# 6 PIN DIP PHOTO COUPLER Schmitt Trigger

## H11Lx Series

### Features:

- High data rate, 1MHz typical (NRZ)
- Free from latch up and oscillation throughout voltage and temperature ranges.
- Microprocessor compatible drive
- Logic compatible output sinks 16mA at 0.4V maximum
- Guaranteed on/off threshold hysteresis
- Wide supply voltage capability, compatible with all popular logic systems
- High isolation voltage between input and output (Viso=5000 V rms )
- Compact dual-in-line package
- Pb free and RoHS compliant.
- UL approved (No. E214129)
- VDE approval (No.132249 )
- SEMKO approved
- NEMKO approved
- DEMKO approved
- FIMKO approved
- CSA approved (No. 2007798)



### Description

The H11LX series of devices each consist of a GaAs infrared emitting diode optically coupled a high speed integrated circuit detector. The output detector incorporates a Schmitt trigger, which provides hysteresis for noise immunity and pulse shaping.

The devices are in a 6-pin DIP package and available in wide-lead spacing and SMD option.

### Applications

- Logic to logic isolator
- Programmable current level sensor
- Line receiver — eliminate noise and transient problems
- AC to TTL conversion — square wave shaping
- Digital programming of power supplies
- Interfaces computers with peripherals

### Schematic

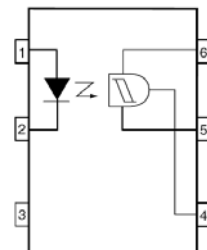

1. Anode
2. Cathode
3. No Connection
4.  $V_O$
5. GND
6.  $V_{CC}$

### Truth Table

Input	Output
H	L
L	H



LIGHTING FOREVER

# 6 PIN DIP PHOTO COUPLER Schmitt Trigger

## H11Lx Series

### Absolute Maximum Ratings ( $T_a=25^{\circ}\text{C}$ )

Parameter		Symbol	Rating	Unit
Input	Forward current	$I_F$	60	mA
	Reverse voltage	$V_R$	6	V
	Power dissipation	$P_D$	120	mW
Output	$V_{45}$ Allowed Range	$V_o$	0 to 16	V
	$V_{65}$ Allowed Range	$V_{CC}$	3 to 16	V
	Output Current	$I_o$	50	mA
	power dissipation	$P_D$	150	mW
Total power dissipation		$P_{tot}$	250	mW
Isolation voltage <sup>*1</sup>		$V_{iso}$	5000	V rms
Operating temperature		$T_{opr}$	-55~+100	°C
Storage temperature		$T_{stg}$	-55~+150	°C
Soldering temperature <sup>*2</sup>		$T_{sol}$	260	°C

#### Notes

\*1 AC for 1 minute, R.H.= 40 ~ 60% R.H. In this test, pins 1, 2 & 3 are shorted together, and pins 4, 5 & 6 are shorted together.

\*2 For 10 seconds.



LIGHTING FOREVER

# 6 PIN DIP PHOTO COUPLER

## Schmitt Trigger

## H11Lx Series

### Electrical Characteristics (T<sub>a</sub>=25°C unless specified otherwise)

#### Input

Parameter	Symbol	Min.	Typ.*	Max.	Unit	Condition
Forward voltage	V <sub>F</sub>	-	1.15	1.5	V	I <sub>F</sub> = 10mA
Reverse Leakage current	I <sub>R</sub>	-	-	10	μA	V <sub>R</sub> = 5V
Capacitance	C <sub>J</sub>	-	-	100	pF	V=0, f=1MHz

#### Output

Parameter	Symbol	Min.	Typ.*	Max.	Unit	Condition
Operation Voltage Range	V <sub>CC</sub>	3	-	15	V	
Supply Current	I <sub>CC(off)</sub>	-	1.6	5	mA	I <sub>F</sub> =0mA, V <sub>CC</sub> =5V
Output Current, High	I <sub>OH</sub>	-	-	100	μA	I <sub>F</sub> =0mA, V <sub>CC</sub> =V <sub>O</sub> =15V
Isolation Resistance	R <sub>ISO</sub>	10 <sup>11</sup>	-	-	Ω	V <sub>I-O</sub> =500VDC

### Transfer Characteristics

Parameter	Symbol	Min.	Typ.*	Max.	Unit	Condition
Supply Current	I <sub>CC(on)</sub>	-	1.6	5	mA	I <sub>F</sub> =10mA, V <sub>CC</sub> =5V
Output Voltage .low	V <sub>OL</sub>	-	-	0.4	V	V <sub>CC</sub> =5V, I <sub>F</sub> =I <sub>Fon</sub> (max.), R <sub>L</sub> =270Ω
Turn on Threshold Current <sup>1</sup>	H11L1	-	-	1.6	mA	V <sub>CC</sub> =5V, R <sub>L</sub> =270Ω
	H11L2	-	-	10		
	H11L3	-	-	5		
Turn off Threshold Current	I <sub>Foff</sub>	-	1	-	mA	V <sub>CC</sub> =5V, R <sub>L</sub> =270Ω
Hysteresis Ratio	I <sub>Fon</sub> /I <sub>Foff</sub>	0.5	-	0.9		V <sub>CC</sub> =5V, R <sub>L</sub> =270Ω
Turn on Time	t <sub>on</sub>	-	-	4	μS	V <sub>CC</sub> =5V, I <sub>F</sub> =I <sub>Fon</sub> , R <sub>L</sub> =270Ω
Fall Time	t <sub>r</sub>	-	0.1	-	μS	
Turn off Time	t <sub>off</sub>	-	-	4	μS	
Rise Time	t <sub>r</sub>	-	0.1	-	μS	
Data Rate		-	1	-	MHz	

\* Typical values at T<sub>a</sub> = 25°C

<sup>1</sup>. Max. I<sub>F(ON)</sub> is the maximum current required to trigger the output. For examples, a 1.6mA maximum trigger current would require the LED to be driven at a current greater than 1.6mA to guarantee the device will turn on. A 10% guard band is recommended to account for degradation of the LED over its lifetime. The maximum allowable LED drive current is 60mA.

### Typical Performance Curves

**Figure 1. Forward Current vs Forward Voltage**

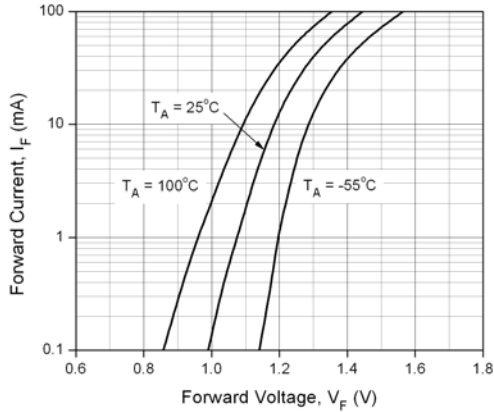

**Figure 2. Transfer Characteristics**

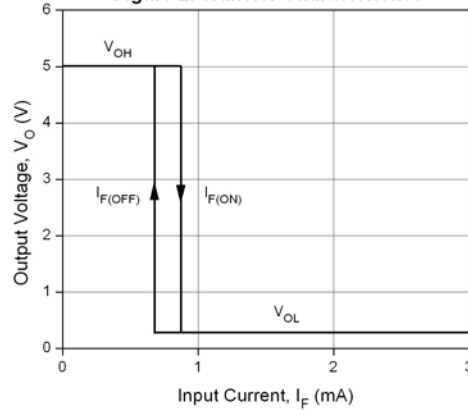

**Figure 3. Turn On Threshold Current vs Supply Voltage**

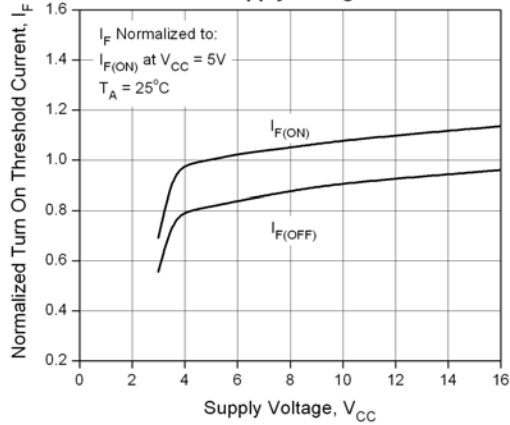

**Figure 4. Turn On Threshold Current vs Ambient Temperature**

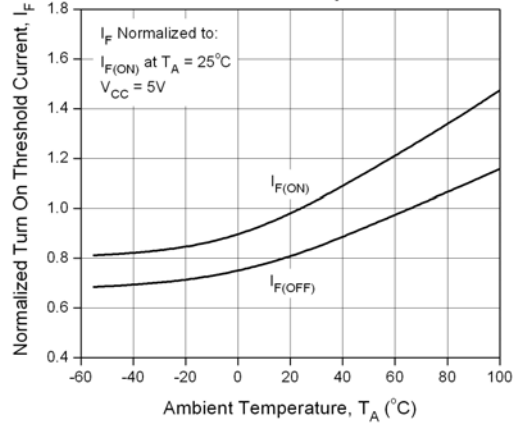

**Figure 5. Low Level Output Voltage vs Load Current**

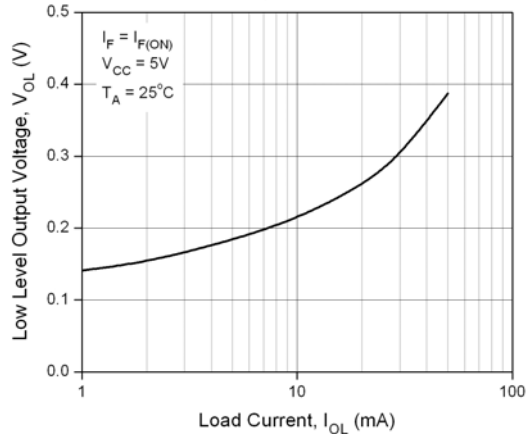

**Figure 6. Supply Current vs Supply Voltage**

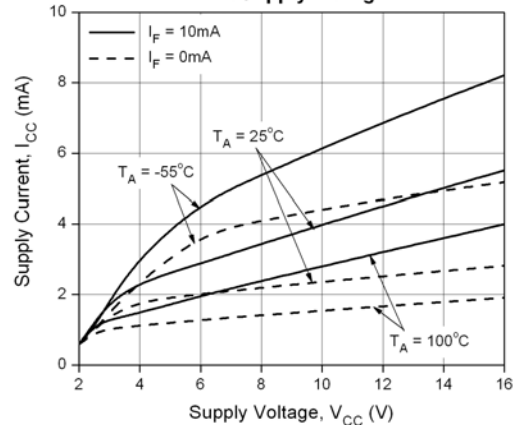

# 6 PIN DIP PHOTO COUPLER Schmitt Trigger

## H11Lx Series

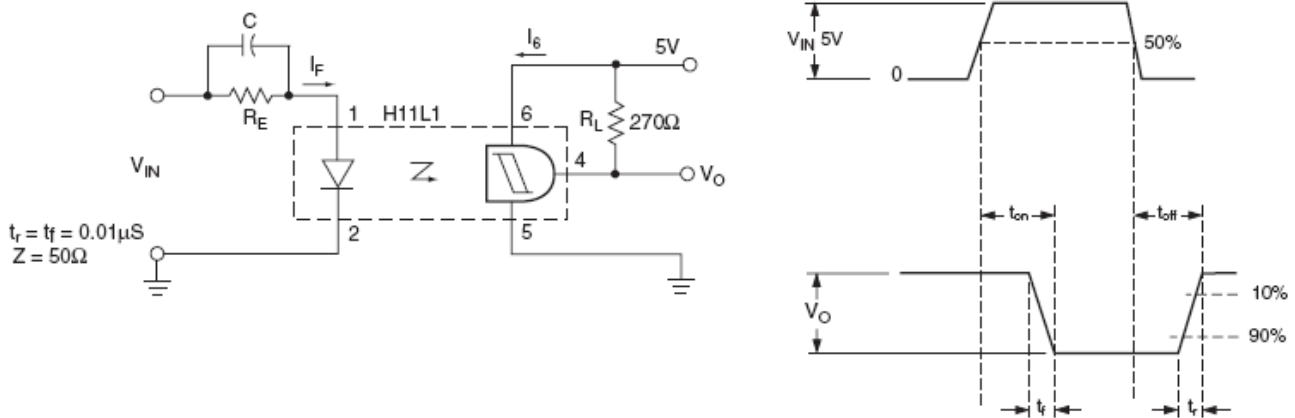

Figure. 7 Switching test circuit and waveform

### Order Information

#### Part Number

# H11LXY(Z)-V

#### Note

- X = Part No. for 1, 2 or 3
- Y = Lead form option (S, S1, M or none)
- Z = Tape and reel option (TA, TB or none).
- V = VDE (optional)

Option	Description	Packing quantity
None	Standard DIP-6	65 units per tube
M	Wide lead bend (0.4 inch spacing)	65 units per tube
S + TA	Surface mount lead form + TA tape & reel option	1000 units per reel
S + TB	Surface mount lead form + TB tape & reel option	1000 units per reel
S1 + TA	Surface mount lead form (low profile) + TA tape & reel option	1000 units per reel
S1 + TB	Surface mount lead form (low profile) + TB tape & reel option	1000 units per reel



LIGHTING FOREVER

# 6 PIN DIP PHOTO COUPLER Schmitt Trigger

## H11Lx Series

### Package Drawings

(Dimensions in mm)

#### Standard DIP Type

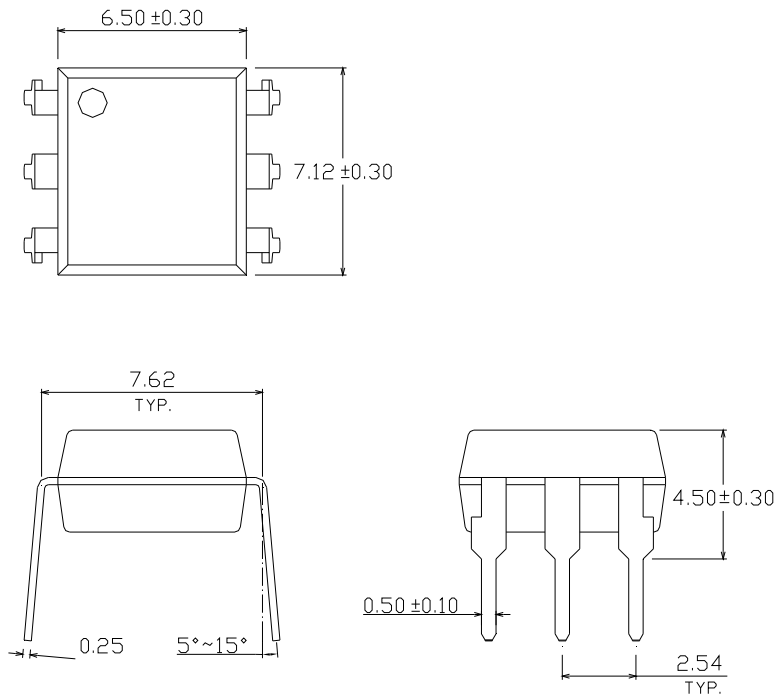

#### Option M Type

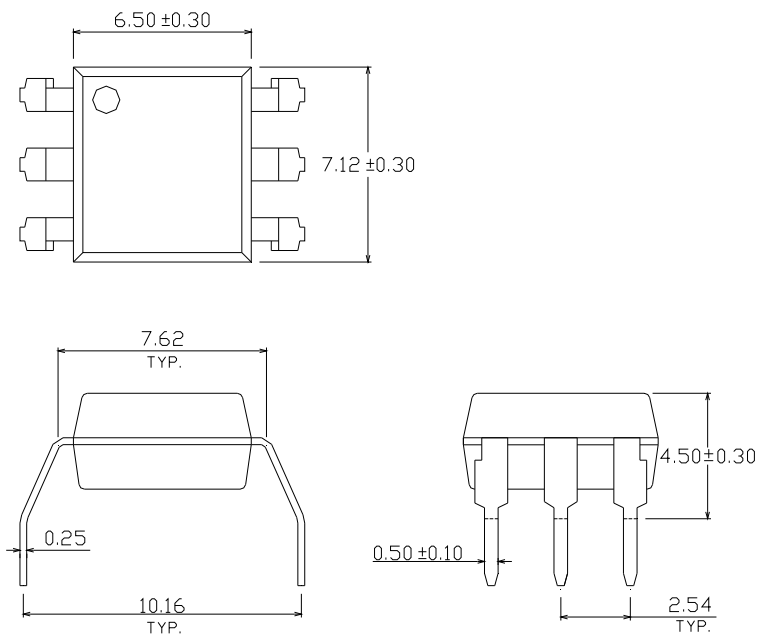



LIGHTING FOREVER

# 6 PIN DIP PHOTO COUPLER Schmitt Trigger

## H11Lx Series

### Option S Type

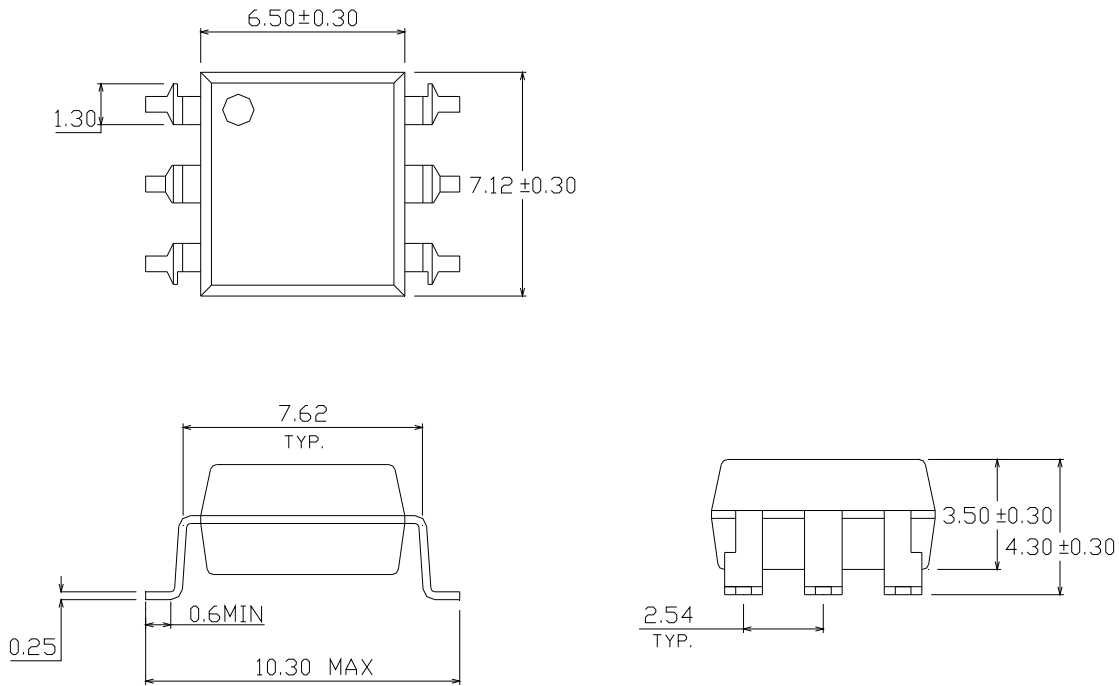

### Option S1 Type

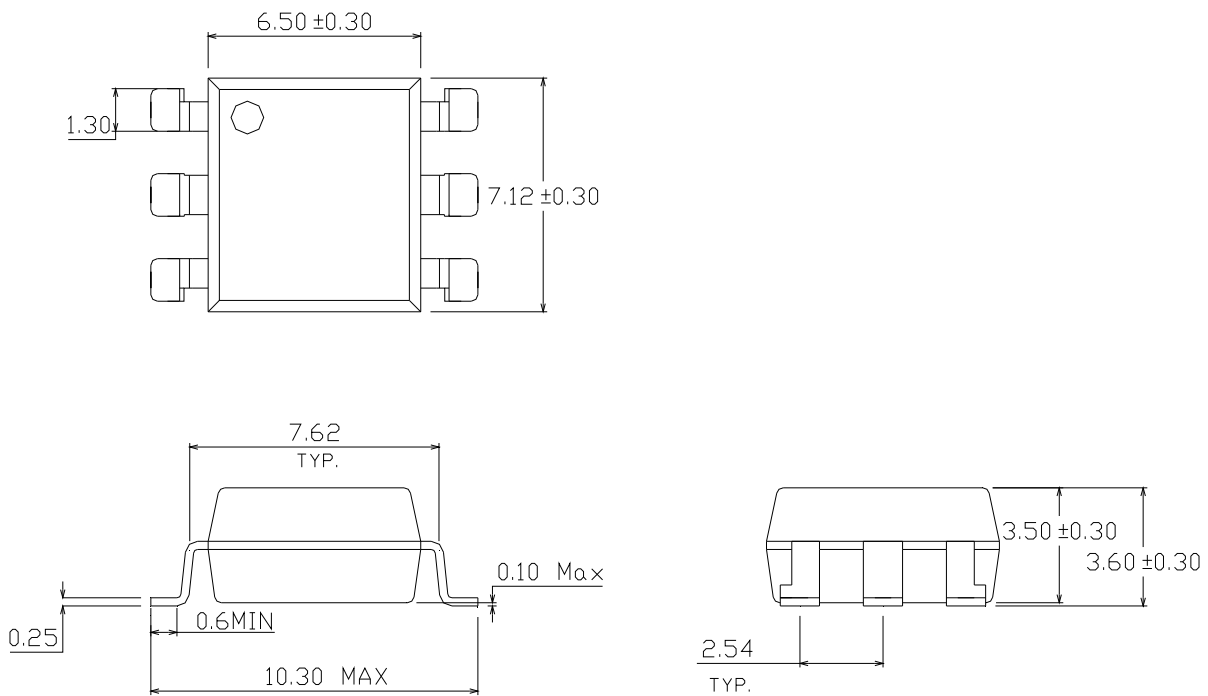



LIGHTING FOREVER

# 6 PIN DIP PHOTO COUPLER Schmitt Trigger

## H11Lx Series

### Recommended pad layout for surface mount leadform

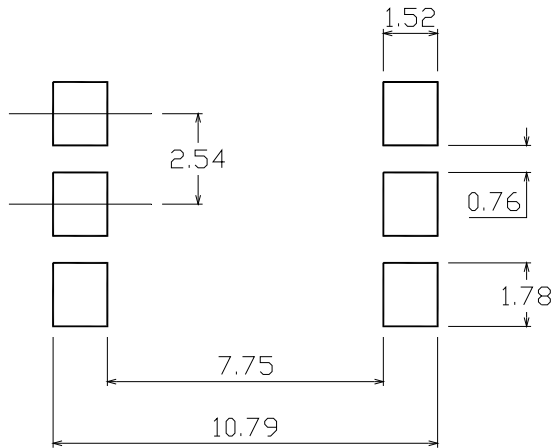

### Device Marking

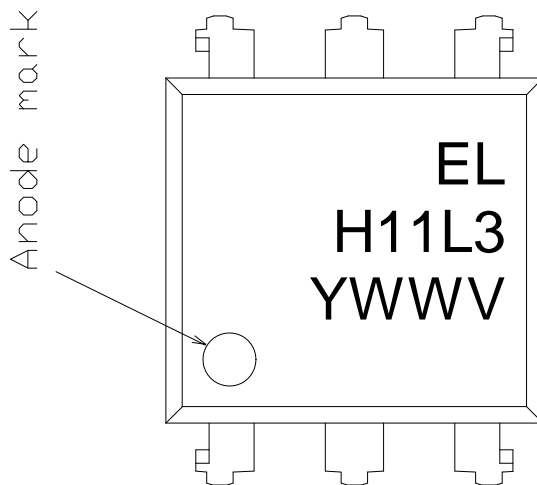

### Notes

- EL denotes Everlight
- H11L3 denotes Device Number
- Y denotes 1 digit Year code
- WW denotes 2 digit Week code
- V denotes VDE (optional)





LIGHTING FOREVER

# 6 PIN DIP PHOTO COUPLER Schmitt Trigger

## H11Lx Series

### Tape & Reel Packing Specifications

**Option TA**

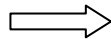
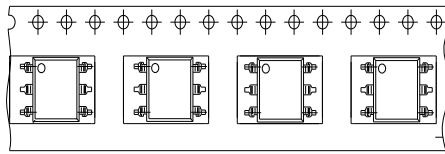

Direction of feed from reel

**Option TB**

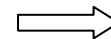
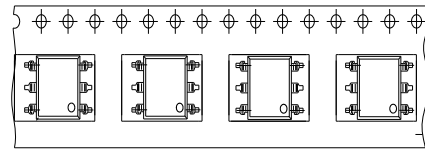

Direction of feed from reel

### Tape dimensions

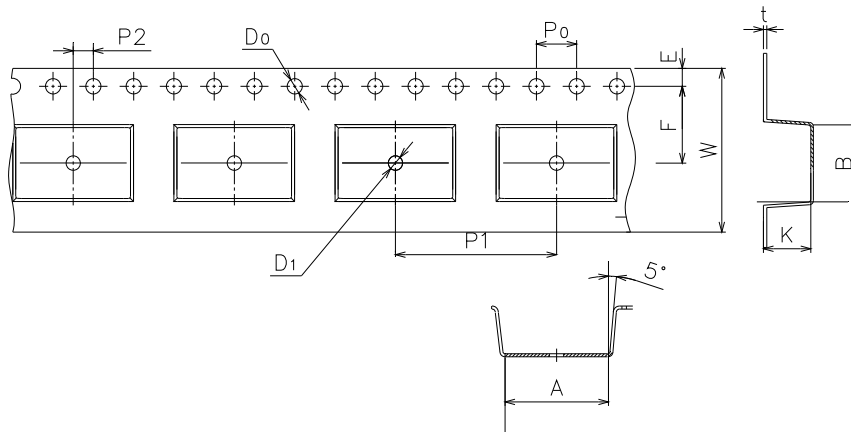

Dimension No.	A	B	Do	D1	E	F
Dimension (mm)	10.4±0.1	7.52±0.1	1.5±0.1	1.5+0.1/-0	1.75±0.1	7.5±0.1

Dimension No.	Po	P1	P2	t	W	K
Dimension (mm)	4.0±0.15	1.6±0.1	2.0±0.1	0.35±0.03	16.0±0.2	4.5±0.1



LIGHTING FOREVER

# 6 PIN DIP PHOTO COUPLER Schmitt Trigger

## H11Lx Series

### Solder Reflow Temperature Profile

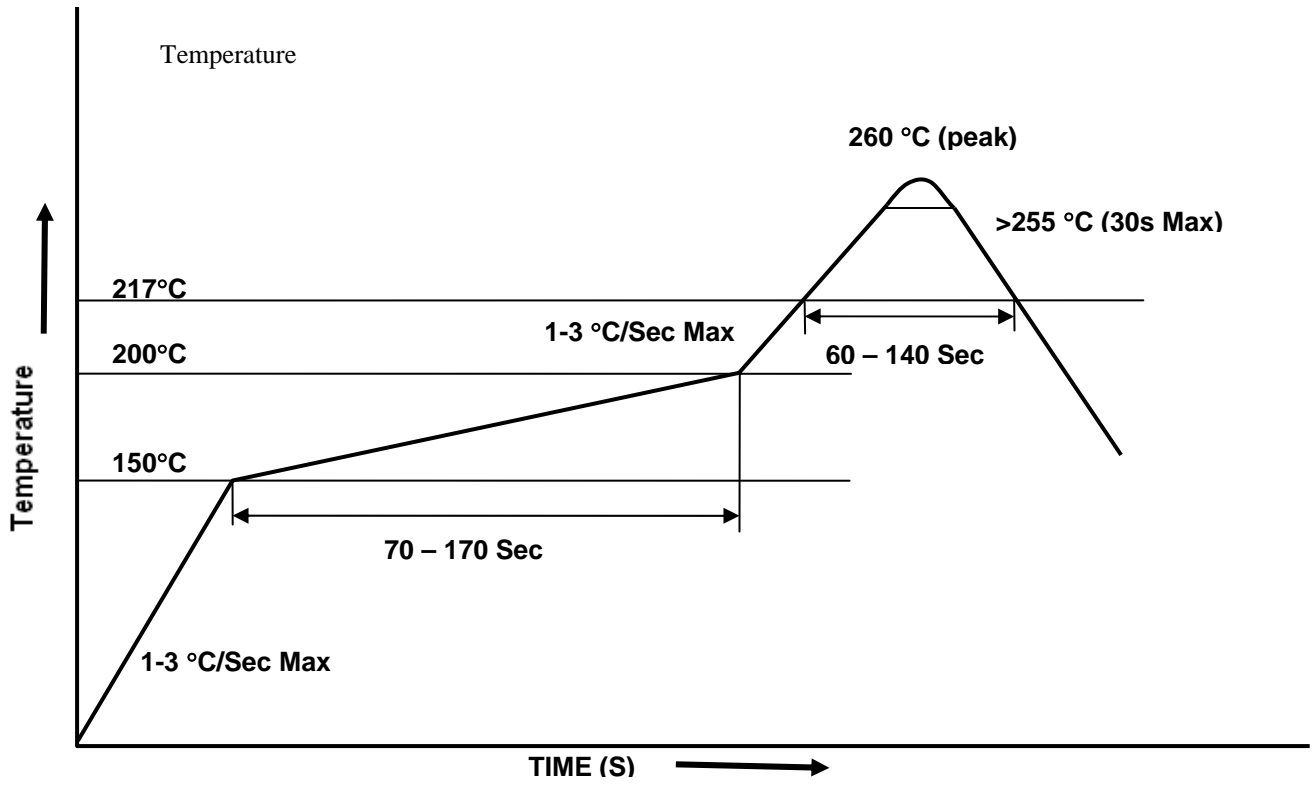



LIGHTING FOREVER

# 6 PIN DIP PHOTO COUPLER

## Schmitt Trigger

## H11Lx Series

---

### DISCLAIMER

1. The specifications in this datasheet may be changed without notice. EVERLIGHT reserves the authority on material change for above specification.
2. When using this product, please observe the absolute maximum ratings and the instructions for use as outlined in this datasheet. EVERLIGHT assumes no responsibility for any damage resulting from use of the product which does not comply with the absolute maximum ratings and the instructions included in this datasheet.
3. These specification sheets include materials protected under copyright of EVERLIGHT. Reproduction in any form is prohibited without the specific consent of EVERLIGHT.



Компания «ЭлектроПласт» предлагает заключение долгосрочных отношений при поставках импортных электронных компонентов на взаимовыгодных условиях!

Наши преимущества:

- Оперативные поставки широкого спектра электронных компонентов отечественного и импортного производства напрямую от производителей и с крупнейших мировых складов;
- Поставка более 17-ти миллионов наименований электронных компонентов;
- Поставка сложных, дефицитных, либо снятых с производства позиций;
- Оперативные сроки поставки под заказ (от 5 рабочих дней);
- Экспресс доставка в любую точку России;
- Техническая поддержка проекта, помощь в подборе аналогов, поставка прототипов;
- Система менеджмента качества сертифицирована по Международному стандарту ISO 9001;
- Лицензия ФСБ на осуществление работ с использованием сведений, составляющих государственную тайну;
- Поставка специализированных компонентов (Xilinx, Altera, Analog Devices, Intersil, Interpoint, Microsemi, Aeroflex, Peregrine, Syfer, Eurofarad, Texas Instrument, Miteq, Cobham, E2V, MA-COM, Hittite, Mini-Circuits, General Dynamics и др.);

Помимо этого, одним из направлений компании «ЭлектроПласт» является направление «Источники питания». Мы предлагаем Вам помощь Конструкторского отдела:

- Подбор оптимального решения, техническое обоснование при выборе компонента;
- Подбор аналогов;
- Консультации по применению компонента;
- Поставка образцов и прототипов;
- Техническая поддержка проекта;
- Защита от снятия компонента с производства.



#### Как с нами связаться

**Телефон:** 8 (812) 309 58 32 (многоканальный)

**Факс:** 8 (812) 320-02-42

**Электронная почта:** [org@eplast1.ru](mailto:org@eplast1.ru)

**Адрес:** 198099, г. Санкт-Петербург, ул. Калинина, дом 2, корпус 4, литера А.