

# Customer Information Sheet

DRAWING No.: M80-5000000M3-XX-XXX-00-000

IF IN DOUBT - ASK

(C)

NOT TO SCALE

THIRD ANGLE PROJECTION

ALL DIMENSIONS IN mm

**SPECIFICATIONS:**

**MATERIAL:**  
 MOULDING: GLASS FILLED PPS, UL94V-0, BLACK  
**COAX CONTACT:**  
 BODY, SLEEVE, INNER CONTACT, END PLUG = COPPER ALLOY  
 LATCHING COLLAR = BERYLLIUM COPPER  
 INSULATOR = PTFE  
 JACKSCREW, NUT = STAINLESS STEEL  
**FINISH:**  
**COAX CONTACT**  
 BODY, SLEEVE, INNER CONTACT, END PLUG = GOLD  
 LATCHING COLLAR: = NICKEL  
**ELECTRICAL:**  
 INSULATION RESISTANCE = 100MΩ MIN  
**COAX CONTACT:**  
 FREQUENCY RANGE = 6GHz  
 IMPEDANCE = 50Ω  
 V.S.W.R = 1.05 + (0.04 x FREQUENCY) GHz MAX  
 CONTACT RESISTANCE = 6mΩ MAX  
 INSULATION RESISTANCE = 10<sup>6</sup>MΩ @250V AC  
 OPERATING VOLTAGE = 180V AC @ 500mA  
 MAXIMUM VOLTAGE = 1000V AC  
**MECHANICAL:**  
 DURABILITY = 500 OPERATIONS  
**COAX CONTACT:**  
 INSERTION FORCE = 8N MAX  
 WITHDRAWAL FORCE = 0.5N MIN  
**ENVIRONMENTAL:**  
 TEMPERATURE RANGE = -55°C TO +125°C  
**PACKING:**  
 BAG  
 FOR COMPLETE SPECIFICATION SEE COMPONENT SPECIFICATION C005XX (LATEST ISSUE)

**COAX CRIMP AND SOLDER CONTACTS ONLY**

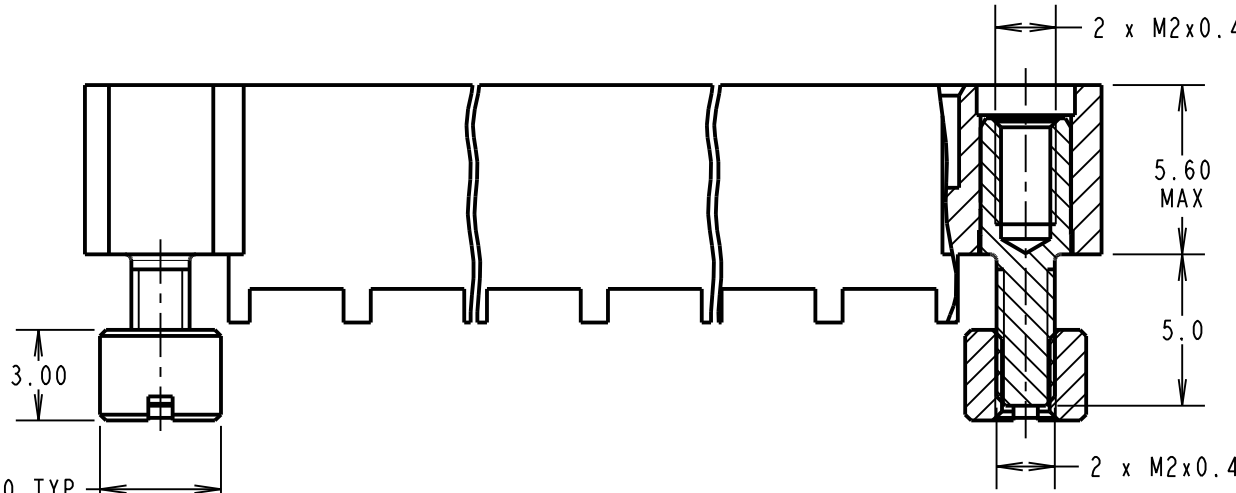
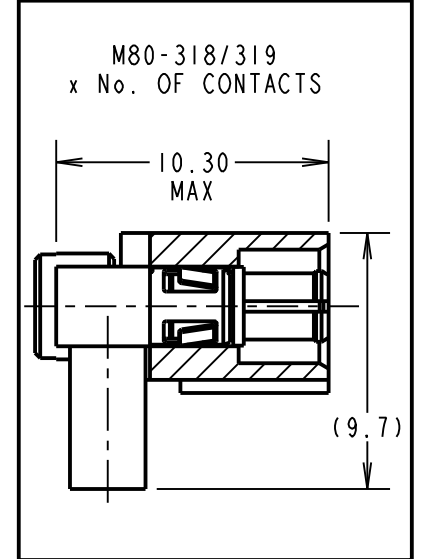
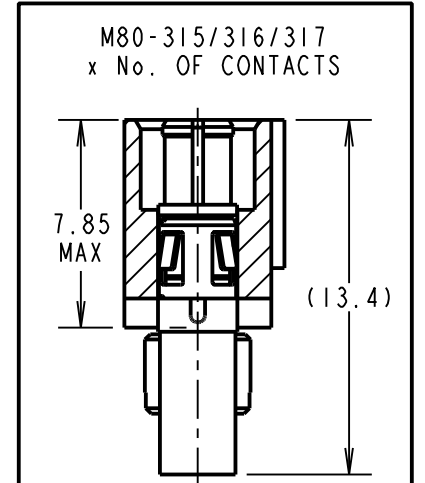
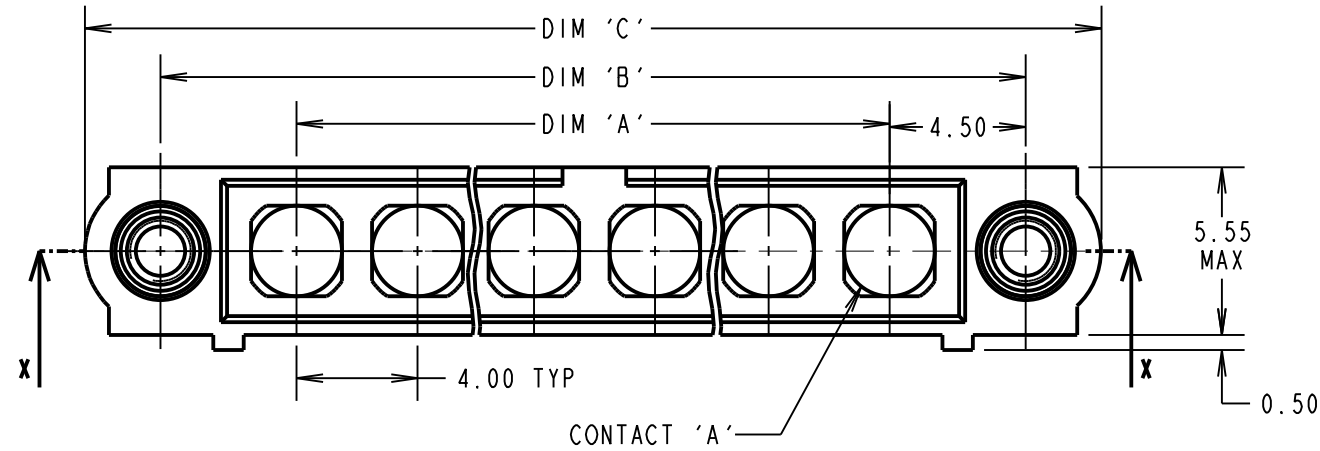

PART SECTION X-X

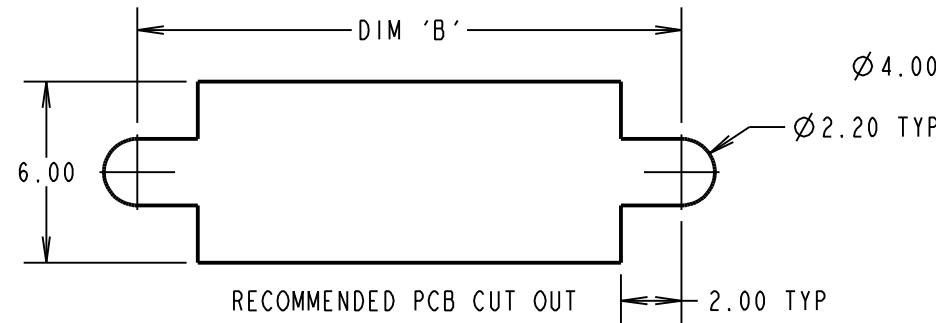

RECOMMENDED PCB CUT OUT

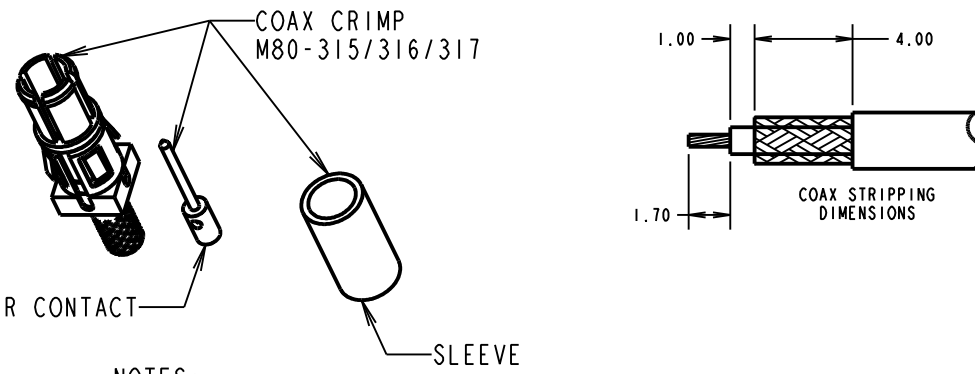
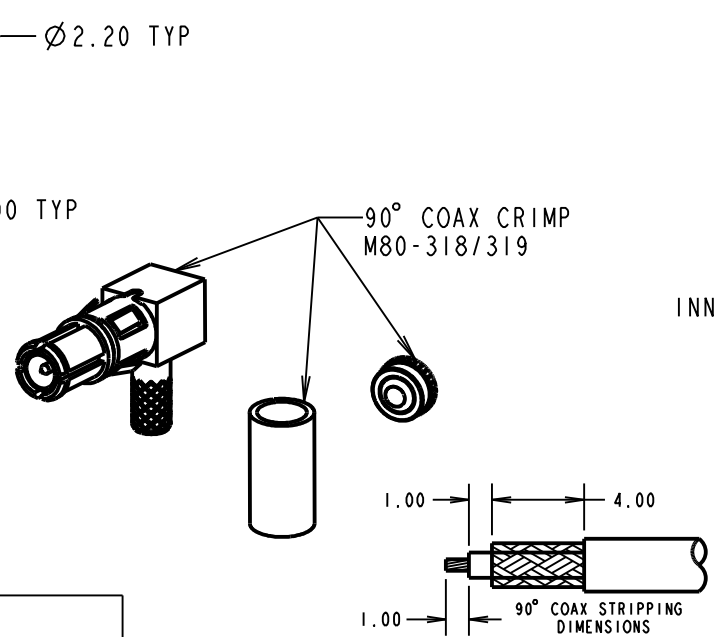

ORDER CODE: (COAX CRIMP/SOLDER CONTACTS)  
**M80-5000000M3-XX-XXX-00-000**  
 TOTAL No. OF CONTACTS: 02 TO 12  
**SPECIAL CONTACTS (CRIMP)**  
 315 = COAX CONTACT 2.0mm CRIMP M80-315  
 316 = COAX CONTACT 2.4mm CRIMP M80-316  
 317 = COAX CONTACT 2.7mm CRIMP M80-317  
 318 = COAX CONTACT 2.0mm HORZ' CRIMP M80-318  
 319 = COAX CONTACT 2.7mm HORZ' CRIMP M80-319

- NOTES:**
- CONNECTORS ARE SUPPLIED WITH CONTACTS LOOSE.
  - COAX CONTACT IS SUPPLIED AS A KIT OF PARTS: BODY, MAIN INSULATOR, INNER CONTACT AND LATCHING COLLAR ARE PRE-ASSEMBLED AND SLEEVE AND INSULATED END PLUG ASSEMBLY ARE SEPARATE.
  - FOR EXTRA COAX CONTACTS, USE PART NUMBERS M80-315/316/317/318/319.
  - CONTACT EXTRACTION TOOL = Z80-290.
  - RECOMMENDED HAND CRIMP TOOL FOR INNER COAX CONTACT = Z80-292 WITH POSITIONER Z80-291. RECOMMENDED HAND CRIMP TOOL AND DIE SET FOR SLEEVE = Z80-293.
  - INSTRUCTION SHEETS ARE AVAILABLE.

MSP	5	11.08.15	12997
NAME	ISS.	DATE	C/NOTE
APPROVED:		M.PERREN	
CHECKED:		S.BENNETT	
DRAWN:		R.ADDE	
CUSTOMER REF.:			
ASSEMBLY DRG.:			

DIMENSION	CALCULATION
DIM 'A'	4 x No. OF CONTACTS - 4.00
DIM 'B'	4 x No. OF CONTACTS + 5.00
DIM 'C'	4 x No. OF CONTACTS + 10.00
EXAMPLE: CONNECTOR WITH 08 COAX CONTACTS, M80-5000000M3-08-315-00-000 DIM 'A' = 28.00mm, DIM 'B' = 37.00mm, DIM 'C' = 42.00mm	

**HARWIN**  
 www.harwin.com  
 technical@harwin.com

THIS DRAWING AND ANY INFORMATION OR DESCRIPTIVE MATTER SET OUT HEREON ARE CONFIDENTIAL AND COPYRIGHT PROPERTY OF THE HARWIN GROUP AND MUST NOT BE DISCLOSED, LOANED, COPIED OR USED FOR MANUFACTURING, TENDERING OR FOR ANY OTHER PURPOSE WITHOUT THEIR WRITTEN PERMISSION.

**TOLERANCES**  
 X. = ±1mm  
 X.X = ±0.50mm  
 X.XX = ±0.10mm  
 X.XXX = ±0.01mm  
 ANGLES = ±5°  
 UNLESS STATED

**MATERIAL:**  
 SEE ABOVE  
**FINISH:**  
 SEE ABOVE  
**S/AREA:**  
 mm<sup>2</sup>

**TITLE:** DATAMATE MIX-TEK MALE ASSEMBLY WITH BOARD MOUNT J/SCREW  
**DRAWING NUMBER:** M80-5000000M3-XX-XXX-00-000  
 SHT 4 OF 6

# Customer Information Sheet

DRAWING No.: M80-500000M3-XX-XXX-00-000

IF IN DOUBT - ASK

(C)

NOT TO SCALE

THIRD ANGLE PROJECTION

ALL DIMENSIONS IN mm

## SPECIFICATIONS:

**MATERIAL:**  
 MOULDING: GLASS FILLED PPS, UL94V-0, BLACK  
**POWER CONTACT:**  
 BODY, SLEEVE, INNER CONTACT, END PLUG = COPPER ALLOY  
 LATCHING COLLAR = BERYLLIUM COPPER  
 INSULATOR = PTFE  
 IOILOK RETAINER = STAINLESS STEEL  
**FINISH:**  
**POWER CONTACT:**  
 BODY, SLEEVE, INNER CONTACT, END PLUG = GOLD  
 LATCHING COLLAR = NICKEL  
**ELECTRICAL:**  
 WORKING VOLTAGE = 800V AC/DC  
 VOLTAGE PROOF = 1200V AC/DC  
 INSULATION RESISTANCE = 100MΩ MIN  
**POWER CONTACT:**  
 CONTACT RESISTANCE = 6mΩ MAX  
 CURRENT RATING = M80-335 = 20A MAX WITH 12AWG  
 M80-336 = 15A MAX WITH 14AWG  
 M80-337 = 10A MAX WITH 16AWG  
 M80-338 = 8A MAX WITH 18AWG  
 M80-339 = 5A MAX WITH 20AWG  
 M80-PM5 = 40A MAX WITH 10AWG  
 CONTACT AS SPECIFIED

**MECHANICAL:**  
 DURABILITY = 500 OPERATIONS  
**POWER CONTACT:**  
 INSERTION FORCE:  
 M80-335/336/337/338/339 = 8N MAX  
 M80-PM5 = 15N MAX  
 WITHDRAWAL FORCE = 0.5N MIN  
**ENVIRONMENTAL:**  
 TEMPERATURE RANGE:  
 M80-335/336/337/338/339 = -55°C TO +125°C  
 M80-PM5 = -55°C TO +150°C  
**PACKING:**  
 BAG  
 FOR COMPLETE SPECIFICATION SEE COMPONENT SPECIFICATION C005XX (LATEST ISSUE)

## POWER CRIMP AND SOLDER CONTACTS ONLY

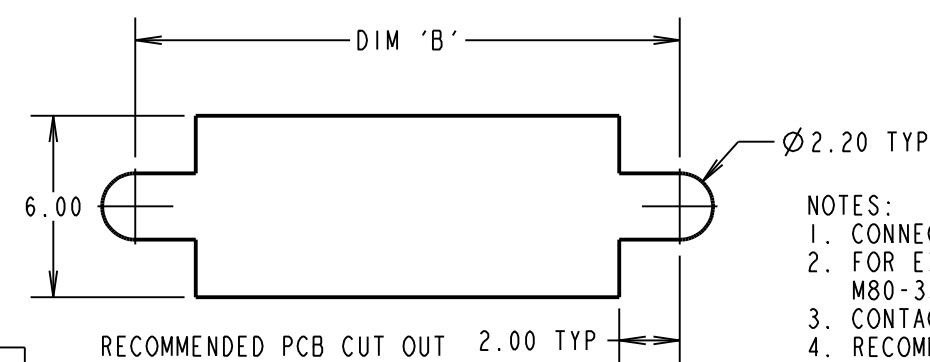
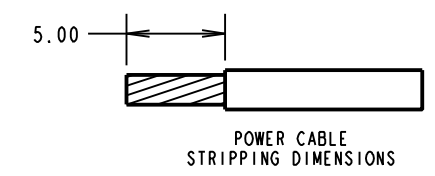
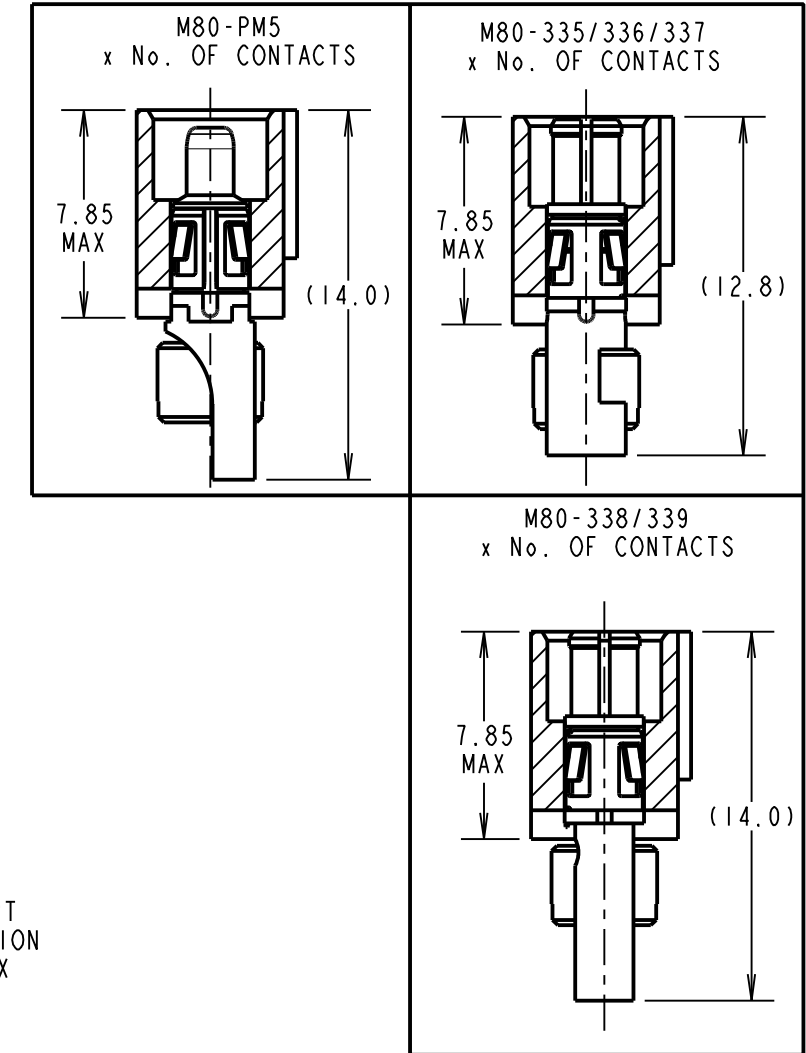
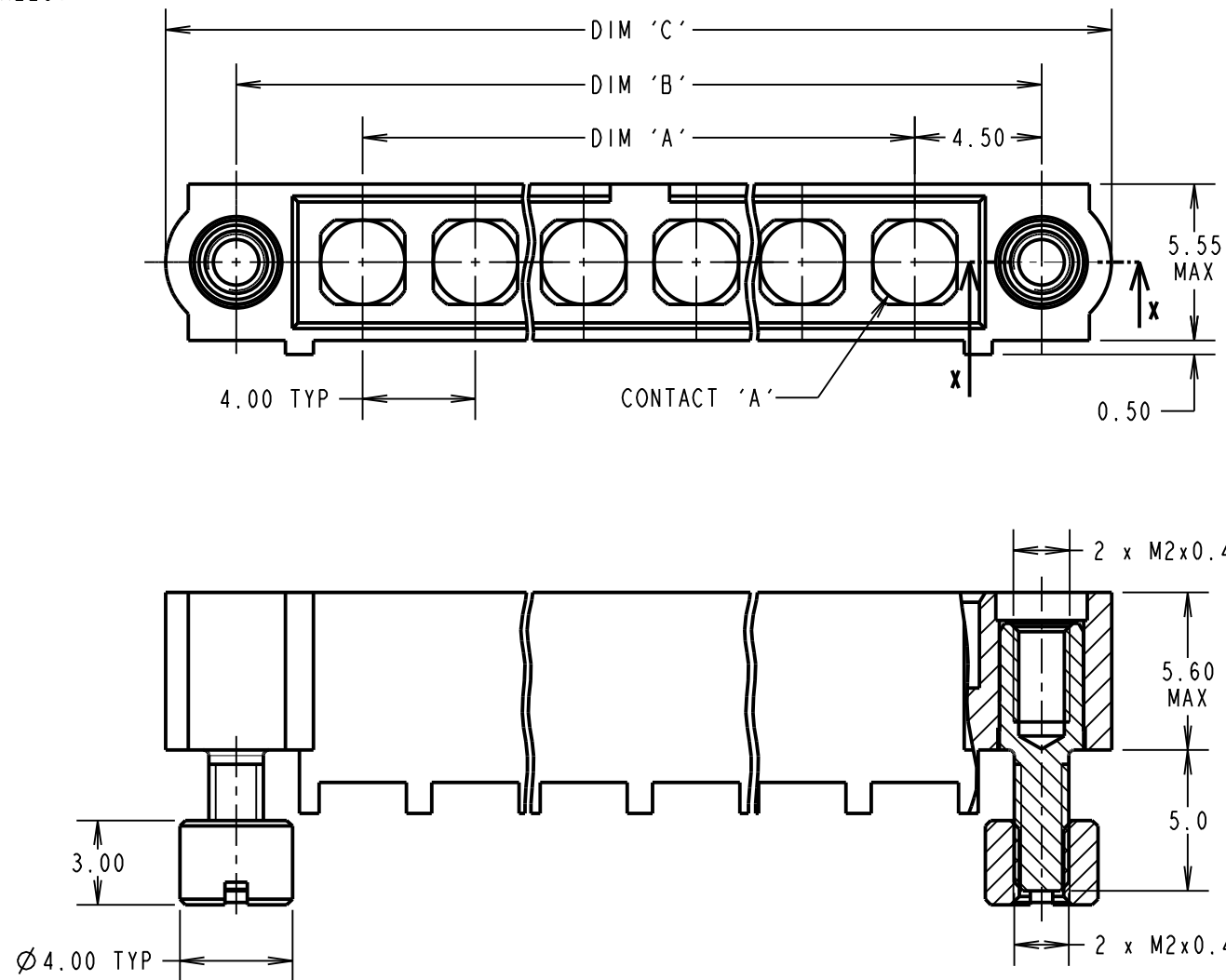

- NOTES:**
- CONNECTORS ARE SUPPLIED WITH CONTACTS LOOSE.
  - FOR EXTRA POWER CONTACTS USE PART NUMBERS: M80-335/336/337/338/339/PM5.
  - CONTACT EXTRACTION TOOL = Z80-290.
  - RECOMMENDED HAND CRIMP TOOL FOR CONTACTS 338/339 = Z80-294 AND POSITIONER Z80-295.
  - INSTRUCTION SHEETS ARE AVAILABLE.

ORDER CODE: (POWER CRIMP/SOLDER CONTACTS)  
**M80-500000M3-XX-XXX-00-000**

TOTAL No. OF CONTACTS \_\_\_\_\_  
 02 TO 12

SPECIAL CONTACTS (CRIMP)  
 335 = POWER CONTACT 12AWG SOLDER M80-335  
 336 = POWER CONTACT 14AWG SOLDER M80-336  
 337 = POWER CONTACT 16AWG SOLDER M80-337  
 338 = POWER CONTACT 18AWG SOLDER/CRIMP M80-338  
 339 = POWER CONTACT 20AWG SOLDER/CRIMP M80-339  
 PM5 = POWER CONTACT 10AWG SOLDER M80-PM5

DIMENSION	CALCULATION
DIM 'A'	4 x No. OF CONTACTS - 4.00
DIM 'B'	4 x No. OF CONTACTS + 5.00
DIM 'C'	4 x No. OF CONTACTS + 10.00
EXAMPLE: CONNECTOR WITH 10 POWER CONTACTS, M80-500000M3-10-335-00-000 DIM 'A' = 36.00mm, DIM 'B' = 45.00mm, DIM 'C' = 50.00mm	

MSP	5	11.08.15	12997
NAME	ISS.	DATE	C/NOTE
APPROVED:		M.PERREN	
CHECKED:		S.BENNETT	
DRAWN:		R.ADDE	
CUSTOMER REF.:			
ASSEMBLY DRG:			

 www.harwin.com technical@harwin.com	THIS DRAWING AND ANY INFORMATION OR DESCRIPTIVE MATTER SET OUT HEREON ARE CONFIDENTIAL AND COPYRIGHT PROPERTY OF THE HARWIN GROUP AND MUST NOT BE DISCLOSED, LOANED, COPIED OR USED FOR MANUFACTURING, TENDERING OR FOR ANY OTHER PURPOSE WITHOUT THEIR WRITTEN PERMISSION.	TOLERANCES X. = ±1mm X.X = ±0.50mm X.XX = ±0.10mm X.XXX = ±0.01mm ANGLES = ±5° UNLESS STATED	MATERIAL: SEE ABOVE	TITLE: DATAMATE MIX-TEK MALE ASSEMBLY WITH BOARD MOUNT J/SCREW
			FINISH: SEE ABOVE	DRAWING NUMBER: <b>M80-500000M3-XX-XXX-00-000</b>

# Customer Information Sheet

DRAWING No.: M80-5000000M3-XX-XXX-00-000

IF IN DOUBT - ASK

(C)

NOT TO SCALE

THIRD ANGLE PROJECTION

ALL DIMENSIONS IN mm

**SPECIFICATIONS:**

**MATERIAL:**  
 MOULDING: GLASS FILLED PPS, UL94V-0, BLACK  
 POWER CONTACT: COPPER ALLOY  
 COAX CONTACT:  
 BODY = COPPER ALLOY  
 INNER CONTACT = COPPER ALLOY  
 INSULATOR = PTFE  
 JACKSCREW, NUT = STAINLESS STEEL

**FINISH:**  
 POWER CONTACT: GOLD  
 COAX CONTACT: BODY, INNER CONTACT = GOLD

**ELECTRICAL:**  
 WORKING VOLTAGE = 800V AC/DC  
 VOLTAGE PROOF = 1200V AC/DC  
 INSULATION RESISTANCE = 100MΩ MIN

**POWER CONTACT:**  
 CONTACT RESISTANCE = 6mΩ MAX  
 CURRENT RATING:  
 M80-331/332 = 20A MAX  
 M80-PM1/PM2 = 40A MAX

**COAX CONTACT:**  
 FREQUENCY RANGE = 6GHz  
 IMPEDANCE = 50Ω  
 V.S.W.R = 1.05 + (0.04 x FREQUENCY) GHz MAX  
 CONTACT RESISTANCE = 6mΩ MAX  
 INSULATION RESISTANCE = 10<sup>9</sup>MΩ @250V AC  
 OPERATING VOLTAGE = 180V AC @ 500mA  
 MAXIMUM VOLTAGE = 1000V AC

**MECHANICAL:**  
 DURABILITY = 500 OPERATIONS

**POWER CONTACT:**  
 INSERTION FORCE:  
 M80-331/332 = 8N MAX  
 M80-PM1/PM2 = 15N MAX  
 WITHDRAWAL FORCE = 0.5N MIN

**COAX CONTACT:**  
 INSERTION FORCE = 8N MAX  
 WITHDRAWAL FORCE = 0.5N MIN

**ENVIRONMENTAL:**  
 TEMPERATURE RANGE:  
 M80-311/312/331/332 = -55°C TO +125°C  
 M80-PM1/PM2 = -55°C TO +150°C

**PACKING:**  
 TUBE  
 FOR COMPLETE SPECIFICATION SEE COMPONENT SPECIFICATION C005XX (LATEST ISSUE)

## COAX PC TAIL CONTACTS ONLY

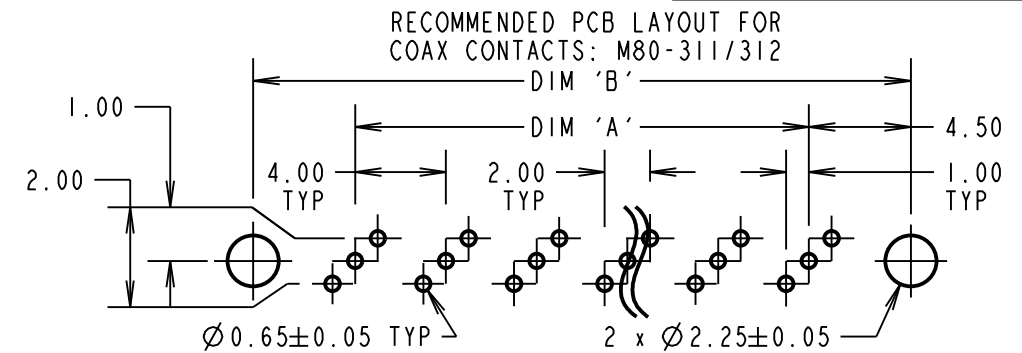
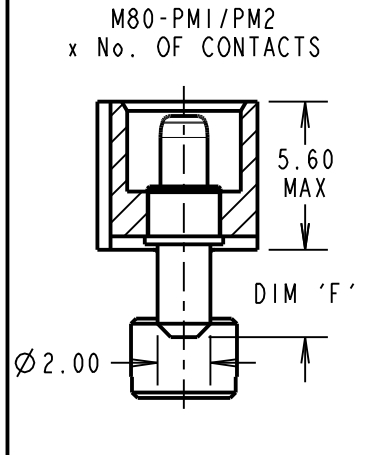
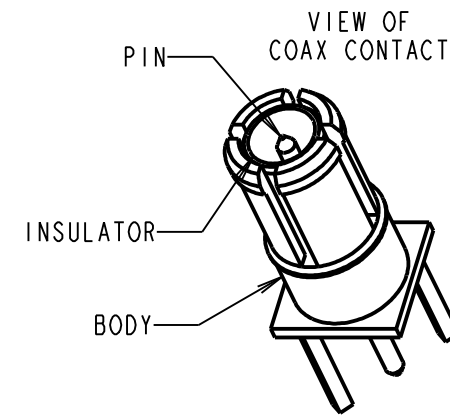
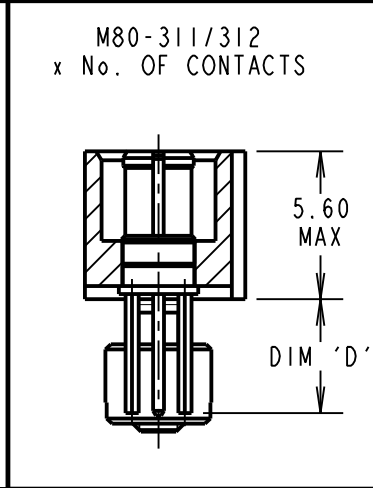
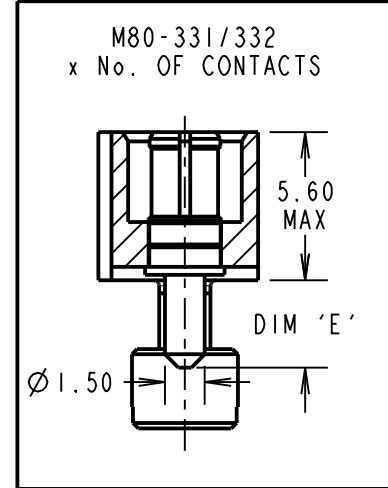
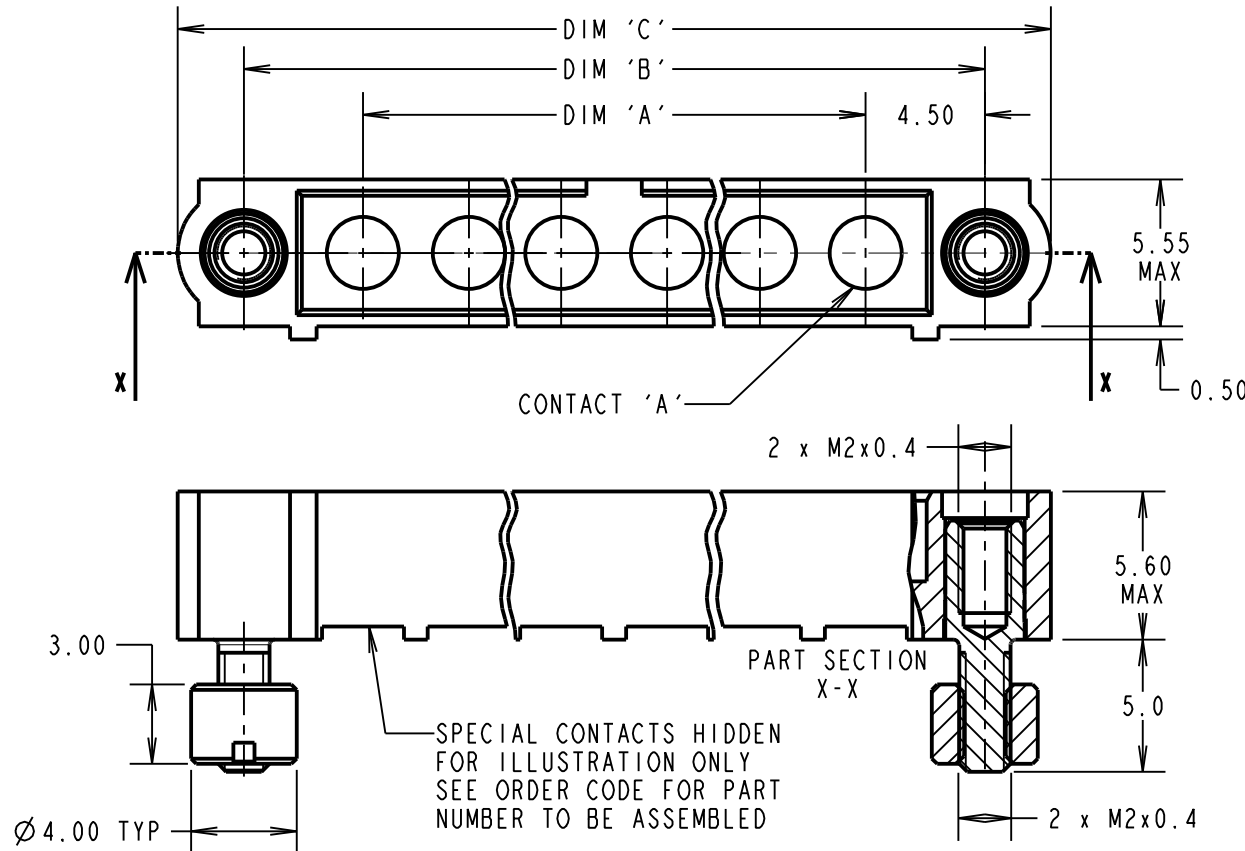

RECOMMENDED PCB LAYOUT FOR POWER CONTACTS: M80-331/332

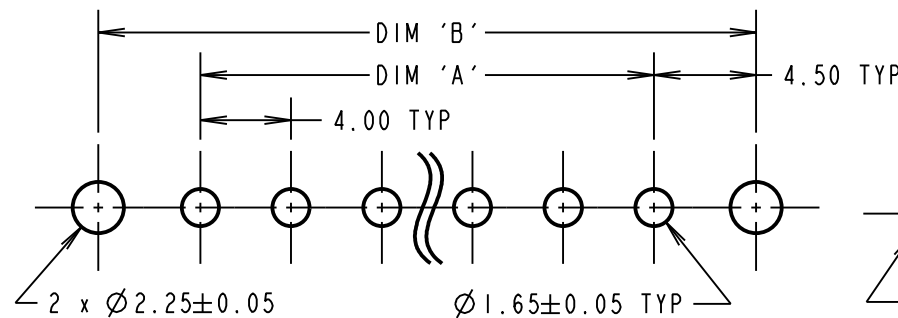

RECOMMENDED PCB LAYOUT FOR POWER CONTACTS: M80-PM1/PM2

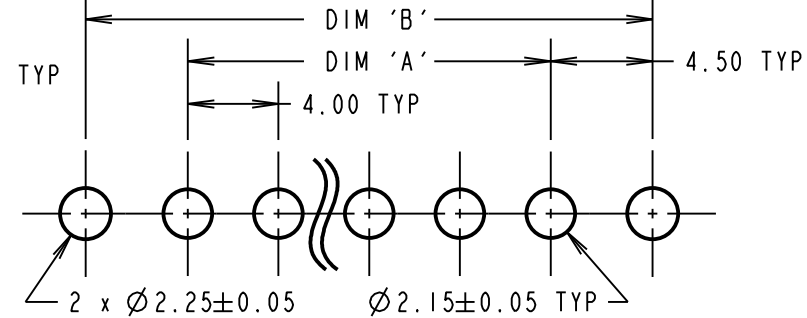

ORDER CODE: (COAX PC TAIL CONTACTS ONLY)  
**M80-5000000M3-XX-XXX-00-000**

TOTAL No. OF CONTACTS  
 02 TO 12

SPECIAL CONTACTS (PC TAIL)  
 311 = COAX CONTACT 3.0mm PC TAIL M80-311  
 312 = COAX CONTACT 4.5mm PC TAIL M80-312  
 331 = 20A POWER CONTACT 3.5mm VERT' PC TAIL M80-331  
 332 = 20A POWER CONTACT 5.0mm VERT' PC TAIL M80-332  
 PM1 = 40A POWER CONTACT 3.5mm VERT' PC TAIL M80-PM1  
 PM2 = 40A POWER CONTACT 5.0mm VERT' PC TAIL M80-PM2

DIMENSION	CALCULATION
DIM 'A'	4 x No. OF CONTACTS - 4.00
DIM 'B'	4 x No. OF CONTACTS + 5.00
DIM 'C'	4 x No. OF CONTACTS + 10.00
DIM 'D'	M80-311 = 3.0mm, M80-312 = 4.5mm
DIM 'E'	M80-331 = 3.5mm, M80-332 = 5.0mm
DIM 'F'	M80-PM1 = 3.5mm, M80-PM2 = 5.0mm

EXAMPLE: CONNECTOR WITH 08 COAX CONTACTS,  
 M80-5000000M3-08-311-00-000  
 DIM 'A' = 28.00mm, DIM 'B' = 37.00mm, DIM 'C' = 42.00mm  
 DIM 'D' = 3.0mm

MSP	5	11.08.15	12997
NAME	ISS.	DATE	C/NOTE
APPROVED:		M.PERREN	
CHECKED:		S.BENNETT	
DRAWN:		R.ADDE	
CUSTOMER REF.:			
ASSEMBLY DRG:			

**HARWIN**

www.harwin.com  
 technical@harwin.com

THIS DRAWING AND ANY INFORMATION OR DESCRIPTIVE MATTER SET OUT HEREON ARE CONFIDENTIAL AND COPYRIGHT PROPERTY OF THE HARWIN GROUP AND MUST NOT BE DISCLOSED, LOANED, COPIED OR USED FOR MANUFACTURING, TENDERING OR FOR ANY OTHER PURPOSE WITHOUT THEIR WRITTEN PERMISSION.

TOLERANCES  
 X. = ±1mm  
 X.X = ±0.50mm  
 X.XX = ±0.10mm  
 X.XXX = ±0.01mm  
 ANGLES = ±5°  
 UNLESS STATED

MATERIAL:  
 SEE ABOVE  
 FINISH: SEE ABOVE  
 S/AREA: mm<sup>2</sup>

TITLE: DATAMATE MIX-TEK MALE ASSEMBLY WITH BOARD MOUNT J/SCREW  
 DRAWING NUMBER: **M80-5000000M3-XX-XXX-00-000**  
 SHT 6 OF 6



Компания «ЭлектроПласт» предлагает заключение долгосрочных отношений при поставках импортных электронных компонентов на взаимовыгодных условиях!

Наши преимущества:

- Оперативные поставки широкого спектра электронных компонентов отечественного и импортного производства напрямую от производителей и с крупнейших мировых складов;
- Поставка более 17-ти миллионов наименований электронных компонентов;
- Поставка сложных, дефицитных, либо снятых с производства позиций;
- Оперативные сроки поставки под заказ (от 5 рабочих дней);
- Экспресс доставка в любую точку России;
- Техническая поддержка проекта, помощь в подборе аналогов, поставка прототипов;
- Система менеджмента качества сертифицирована по Международному стандарту ISO 9001;
- Лицензия ФСБ на осуществление работ с использованием сведений, составляющих государственную тайну;
- Поставка специализированных компонентов (Xilinx, Altera, Analog Devices, Intersil, Interpoint, Microsemi, Aeroflex, Peregrine, Syfer, Eurofarad, Texas Instrument, Miteq, Cobham, E2V, MA-COM, Hittite, Mini-Circuits, General Dynamics и др.);

Помимо этого, одним из направлений компании «ЭлектроПласт» является направление «Источники питания». Мы предлагаем Вам помощь Конструкторского отдела:

- Подбор оптимального решения, техническое обоснование при выборе компонента;
- Подбор аналогов;
- Консультации по применению компонента;
- Поставка образцов и прототипов;
- Техническая поддержка проекта;
- Защита от снятия компонента с производства.



#### Как с нами связаться

**Телефон:** 8 (812) 309 58 32 (многоканальный)

**Факс:** 8 (812) 320-02-42

**Электронная почта:** [org@eplast1.ru](mailto:org@eplast1.ru)

**Адрес:** 198099, г. Санкт-Петербург, ул. Калинина, дом 2, корпус 4, литера А.