



ITT

Interconnect Solutions
Cannon, VEAM, BIW



Ensuring soldier safety

in the harshest environments for

20 years and over

500,000 SINCGARS radios



Engineered for life

Universal Contact is an independent SMT contact which provides an electrical connection between a device and a PCB. The contact is manufactured as a single piece stamped product, incorporating pre-load and anti-lift features. The Universal Contact has been designed to replace traditional interfaces where the contact is custom designed into the component. It can be used to connect a number of device components in any direction and configuration using the same interface.

Additional Advantages of using Universal Contacts

- Qualification time reduction - same contact for many components
- Allows standard interface across applications and platforms
- Freedom to position at an angle - not fixed by mating component

Features & Benefits of the Design

- Range of heights available:
 - 1.3mm contact with the minimum pitch of 1.35mm
 - 1.8mm contact with the minimum pitch of 1.25mm
 - 2.5mm contact the minimum pitch is 1.35mm
 - 3.5 & 4.0mm minimum pitch is 1.45mm
- Solderwell that prevents solder wicking up the contact
- "Side wings" protect the active parts of the contact which prevent contact from overstressing and potential damage
- Domed contact point allows good hertz stress and low contact resistance
- The X-Y-Z movement allows robust connection between the contact and component assembly during shock and vibration
- Compliant with WEEE and RoHS directives.

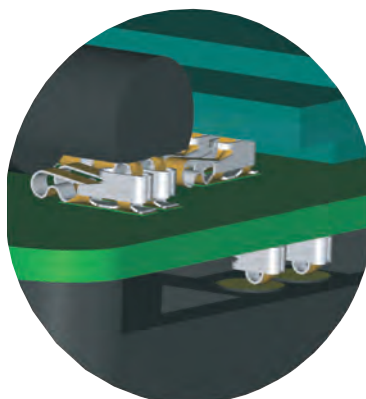

Applications

- Handset
- Solderless component interconnect
- I/O connector / Board to board interconnect
- Battery contact / Antenna contact
- Grounding contact / SIM contact
- Laptops & Computers
- Memory Stick
- Home Electronic Devices / White Goods
- Smoke detectors / Security alarm systems
- Home appliances
- Automotive - Keyfob
- Medical - CT scan equipment
- Industrial - Circuit breaker for GPS beckon

Materials & Finishes

| | |
|---------------|--|
| Base material | Beryllium Copper |
| Plating | Selective Au in contact area 1m min over Au stripe, 0.05 - 0.1 m over Ni 1.0 - 3.0 m |

Electrical

| | |
|--------------------|--------------------------------|
| Contact resistance | Max 20 mΩ |
| Max current rating | 2.0 amps nominal 3.0 amps peak |

Environmental

| | |
|-----------------------|--|
| Operating temperature | -40°C and +85°C |
| Humidity | Operable in 90% relative humidity (temp + 40°C) |

| | |
|----------------|--------------------------------------|
| Solder systems | Infrared and hot air reflow |
| Vibration | In accordance with IEC 68-2-36 |
| Shock | In accordance with IEC 68-2-27, 30 g |

Mechanical See selection table on the right for contact forces at specific mating heights

Maximum mating cycle based on mating PCB plated with 0.05 Au over 2.0 m Ni = 3,000 cycles. (Wear resistance is subject to mating component surface finish and plating type, increased mating component plating spec = increased mating cycles.)

Packaging Packaged in 12mm wide tape & reel packaging to EIA-481 standards

| MATING HEIGHT | 1.3mm | 1.8mm | 2.5mm | 3.5mm | 4.0mm |
|------------------|--------------------------------|----------|----------|----------|----------|
| | FORCE (N) AT COMPRESSED HEIGHT | | | | |
| 0.90 | 0.58 | | | | |
| 1.00 | 0.51 | 0.87 | | | |
| 1.10 | 0.44 | 0.80 | | | |
| 1.20 | 0.37 | 0.74 | | | |
| 1.30 | Pre-load | 0.68 | | | |
| 1.40 | | 0.62 | | | |
| 1.50 | | 0.56 | 0.58 | | |
| 1.60 | | 0.49 | 0.55 | | |
| 1.70 | | 0.43 | 0.52 | | |
| 1.80 | | Pre-load | 0.49 | | |
| 1.90 | | | 0.46 | | |
| 2.00 | | | 0.42 | 0.94 | |
| 2.10 | | | 0.39 | 0.91 | |
| 2.20 | | | 0.36 | 0.87 | |
| 2.30 | | | 0.33 | 0.83 | |
| 2.40 | | | 0.30 | 0.80 | |
| 2.50 | | | Pre-load | 0.76 | 1.30 |
| 2.60 | | | | 0.73 | 1.27 |
| 2.70 | | | | 0.69 | 1.24 |
| 2.80 | | | | 0.65 | 1.22 |
| 2.90 | | | | 0.62 | 1.19 |
| 3.00 | | | | 0.58 | 1.16 |
| 3.10 | | | | 0.55 | 1.13 |
| 3.20 | | | | 0.51 | 1.11 |
| 3.30 | | | | 0.47 | 1.08 |
| 3.40 | | | | 0.44 | 1.05 |
| 3.50 | | | | Pre-load | 1.02 |
| 3.60 | | | | | 1.00 |
| 3.70 | | | | | 0.97 |
| 3.80 | | | | | 0.94 |
| 3.90 | | | | | 0.91 |
| 4.00 | | | | | Pre-load |
| Spring Rate N/mm | 0.68 | 0.62 | 0.32 | 0.36 | 0.28 |



Contacts

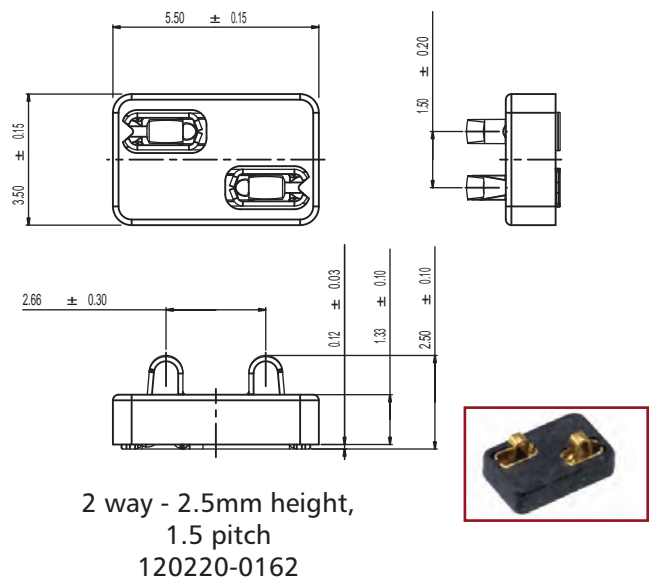
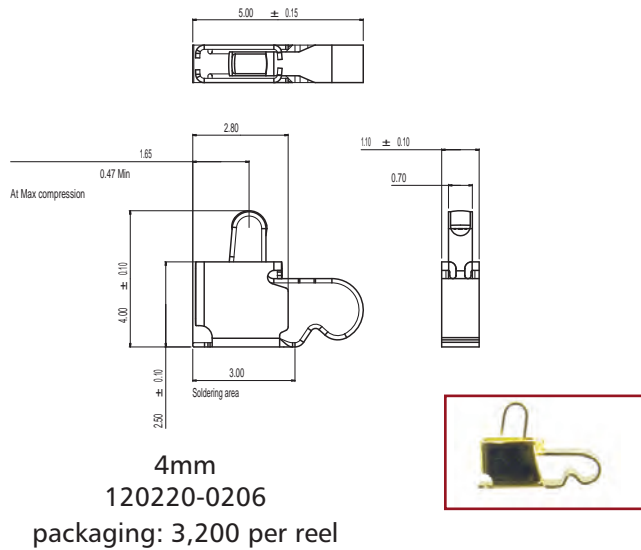
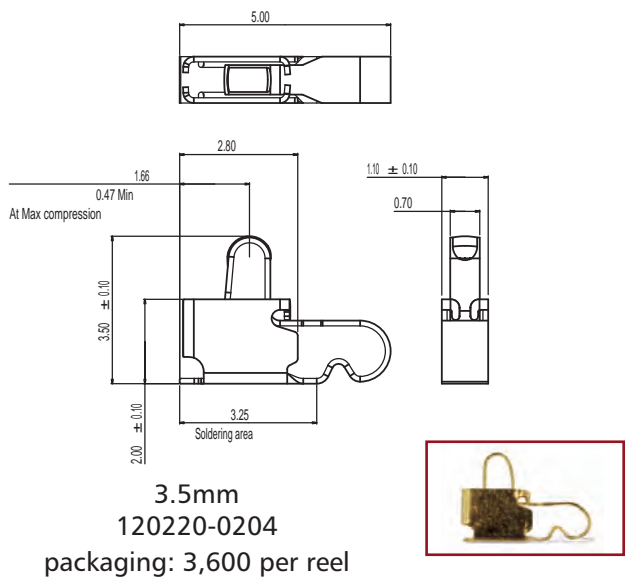
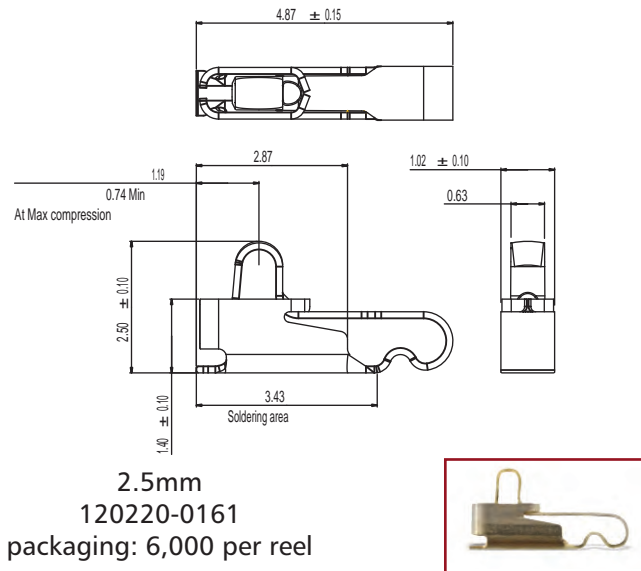
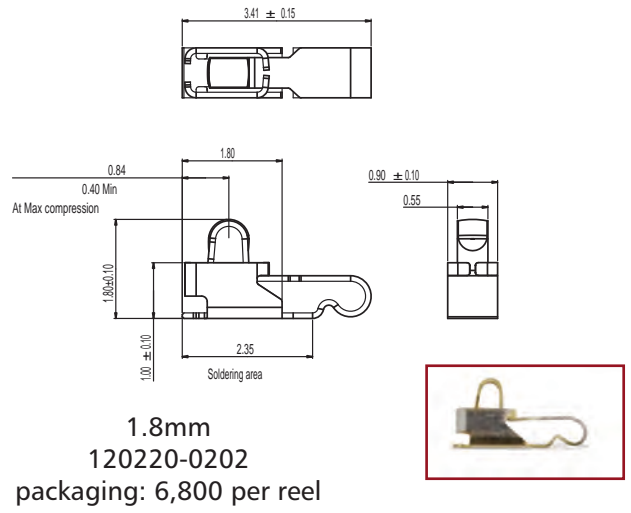
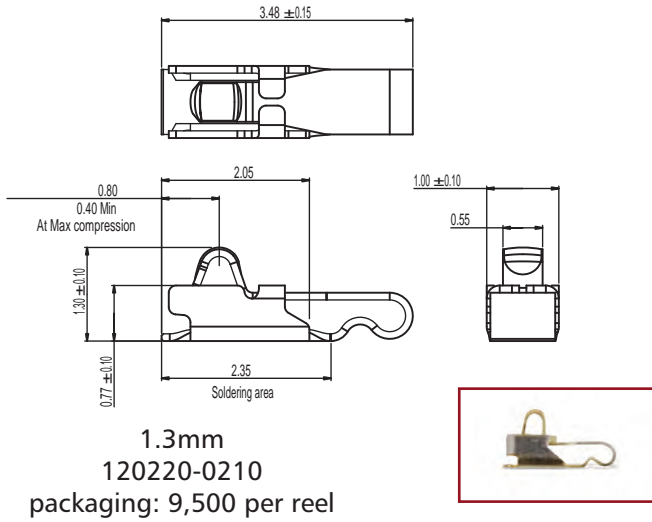



Компания «ЭлектроПласт» предлагает заключение долгосрочных отношений при поставках импортных электронных компонентов на взаимовыгодных условиях!

Наши преимущества:

- Оперативные поставки широкого спектра электронных компонентов отечественного и импортного производства напрямую от производителей и с крупнейших мировых складов;
- Поставка более 17-ти миллионов наименований электронных компонентов;
- Поставка сложных, дефицитных, либо снятых с производства позиций;
- Оперативные сроки поставки под заказ (от 5 рабочих дней);
- Экспресс доставка в любую точку России;
- Техническая поддержка проекта, помощь в подборе аналогов, поставка прототипов;
- Система менеджмента качества сертифицирована по Международному стандарту ISO 9001;
- Лицензия ФСБ на осуществление работ с использованием сведений, составляющих государственную тайну;
- Поставка специализированных компонентов (Xilinx, Altera, Analog Devices, Intersil, Interpoint, Microsemi, Aeroflex, Peregrine, Syfer, Eurofarad, Texas Instrument, Miteq, Cobham, E2V, MA-COM, Hittite, Mini-Circuits, General Dynamics и др.);

Помимо этого, одним из направлений компании «ЭлектроПласт» является направление «Источники питания». Мы предлагаем Вам помощь Конструкторского отдела:

- Подбор оптимального решения, техническое обоснование при выборе компонента;
- Подбор аналогов;
- Консультации по применению компонента;
- Поставка образцов и прототипов;
- Техническая поддержка проекта;
- Защита от снятия компонента с производства.



Как с нами связаться

Телефон: 8 (812) 309 58 32 (многоканальный)

Факс: 8 (812) 320-02-42

Электронная почта: org@eplast1.ru

Адрес: 198099, г. Санкт-Петербург, ул. Калинина, дом 2, корпус 4, литера А.