

NCL30060

High PF Offline Single Stage LED Driver with High Voltage Startup

The NCL30060 is a switch mode power supply controller intended for low to medium power single stage power factor (PF) corrected LED Drivers. It employs a constant on-time control method to ensure near unity power factor across a wide range of input voltages and output power. It can be used for isolated flyback as well as buck topologies. The device offers a suite of robust protection features to ensure safe operation under a range of fault conditions.

Features

- Built-In High Voltage Start-up Circuit
- Direct Opto-coupler Feedback Connection
- Constant On-Time PWM Control
- Quasi-Resonant Switching
- Low Operating Current (1.6 mA typical)
- Source 250 mA / Sink 400 mA Totem Pole Gate Driver
- Integrated 12 V (typ) Gate Drive Clamp
- Frequency Dithering for Reduced EMI Profile
- Enable/Disable Function
- Dynamic Self-Supply (DSS) Operation
- Operating T_j from -40°C to 105°C
- Maximum On Time Protection
- Integrated Brown-out
- Overvoltage Protection
- Cycle-by-Cycle Overcurrent Protection
- Output Winding Short-Circuit Protection
- Thermal Shutdown
- These Devices are Pb-Free and Halogen Free/BFR Free

Typical Applications

- LED Lighting



ON Semiconductor®

<http://onsemi.com>

MARKING DIAGRAM

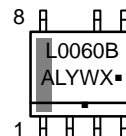

L0060B = Specific Device Code
A = Assembly Location
L = Wafer Lot
Y = Year
W = Work Week
▪ = Pb-Free Package
(Note: Microdot may be in either location)

PIN CONNECTIONS

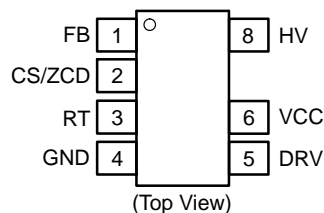

ORDERING INFORMATION

See detailed ordering and shipping information on page 14 of this data sheet.

NCL30060

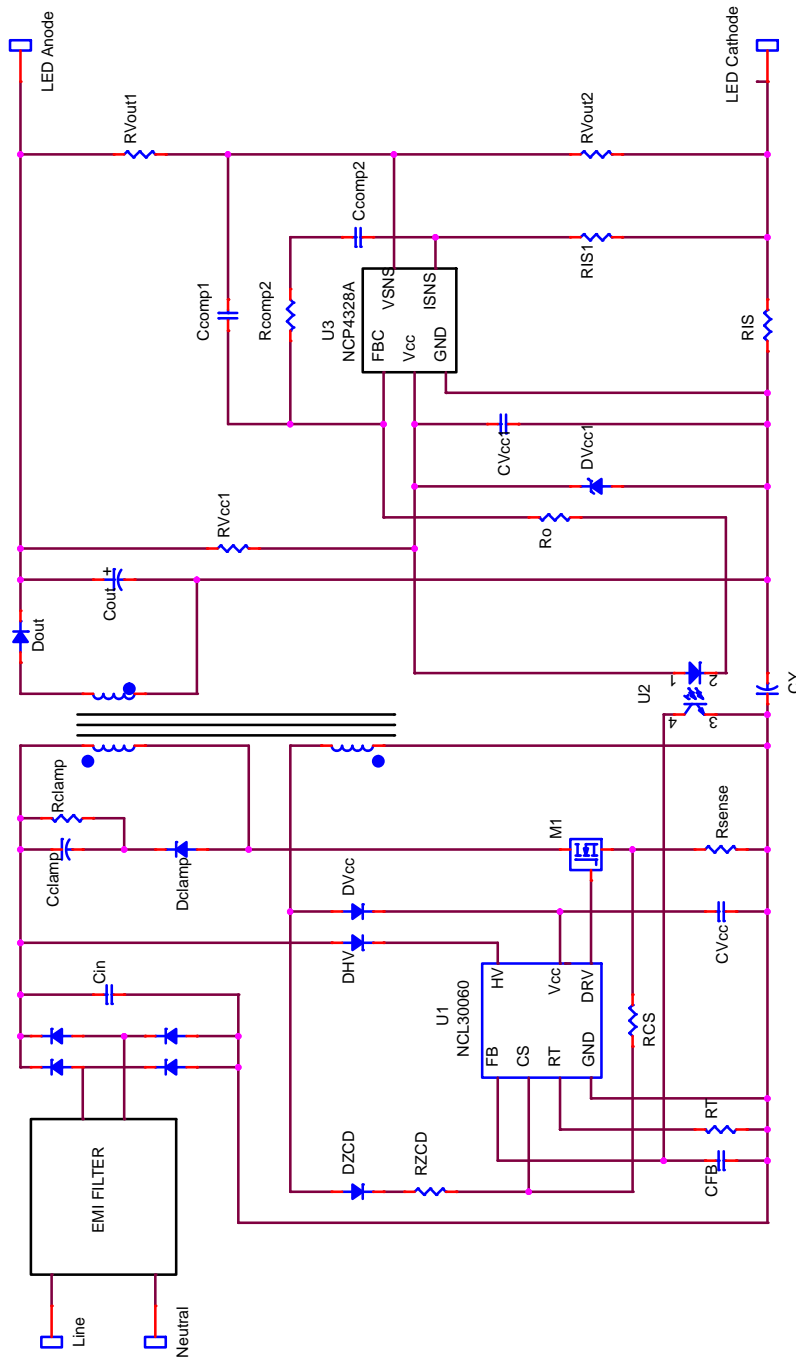

Figure 1. NCL30060 Typical Application Diagram

NCL30060

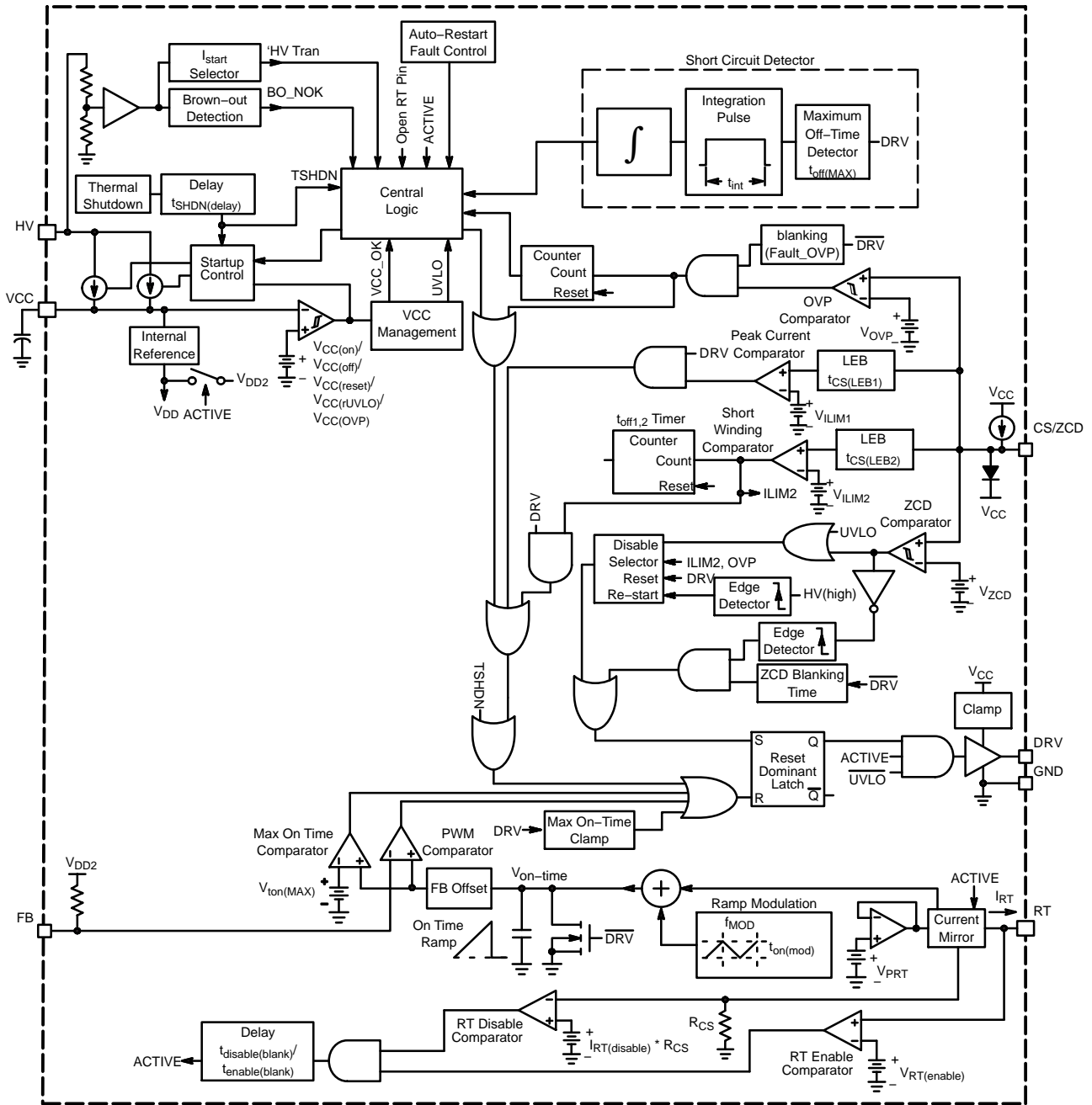

Figure 2. NCL30060 Internal Functional Block Diagram

NCL30060

Table 1. NCL30060 PIN FUNCTION DESCRIPTION

Pin No	Pin Name	Pin Description
1	FB	Feedback Input. The FB pin is the control input to the PWM comparator. A voltage level controlled by the feedback loop on this pin is compared to the internal ramp establishing power switch on time.
2	CS/ZCD	Current sense and zero current detection. The CS input is used to sense the instantaneous switch current in the external power switch during switch on time. A fast-responding high threshold level for short circuit detection is provided along with a longer blanking time at lower level for overload conditions. During switch off time, this pin monitors the bias winding to detect transformer demagnetization. When stored energy is depleted the gate drive turns on the power switch initiating the next cycle. This pin also detects overvoltage conditions through the bias winding. A blanking time prevents false overvoltage triggering due to noise.
3	RT	Maximum on-time adjust. The RT pin establishes the ramp charging current. The PWM comparator establishes the switch on time from the ramp and FB signal. Pulling the RT pin below the disable threshold forces the controller in the Armed mode where all switching functions cease.
4	GND	Ground. This is the ground reference for the controller. All bypassing and control components should be connected to the GND pin with a short trace length to minimize noise.
5	DRV	Drive. The high current capability of the totem pole gate drive makes it suitable to directly control high gate charge power MOSFETs. The driver stage provides both passive and active pull-down circuits which force the MOSFET gate off when VCC is below normal operating levels.
6	VCC	IC Supply. This is the positive supply of the controller and source for powering external circuits. Internal bias will be disabled when external power is sufficient to maintain operation.
7	NC	No-connect. This missing pin provides creepage distance.
8	HV	High-voltage input. Monitors input voltage for brown-out detection and power to operate controller.

NCL30060

Table 2. MAXIMUM RATINGS (Notes 1, 2, 3 and 4)

Rating	Symbol	Value	Unit
FB Voltage	V_{FB}	-0.3 to 10	V
FB Current	I_{FB}	± 10	mA
CS/ZCD Voltage	$V_{CS/ZCD}$	-0.9 to 12.4	V
CS/ZCD Current	$I_{CS/ZCD}$	-2 / +5	mA
RT Voltage	V_{RT}	-0.3 to 5	V
RT Current	I_{RT}	± 10	mA
DRV Voltage (Note 2)	V_{DRV}	-0.3 to $V_{DRV(high)}$	V
DRV Sink Current	$I_{DRV(sink)}$	400	mA
DRV Source Current	$I_{DRV(source)}$	250	mA
Supply Voltage	V_{CC}	-0.3 to 30	V
Supply Voltage Rate of Change	dV_{CC}/dt	1	V/ μs
Supply Current	I_{CC}	20	mA
HV Voltage	V_{HV}	-0.3 to 700	V
HV Current	I_{HV}	20	mA
Thermal Resistance, Junction to Ambient 1 Oz Cu Printed Circuit Copper Clad)	$R_{\theta JA}$	125	$^{\circ}C/W$
ESD Capability Human Body Model per JEDEC Standard JESD22-A114E. (Note 5) Machine Model per JEDEC Standard JESD22-A114E. Charge Device Model per JEDEC Standard JESD22-C101E.		5000 200 1500	V
Operating Temperature Range While Biased	T_J	-40 to 105	$^{\circ}C$
Maximum Junction Temperature	T_{JMax}	150	$^{\circ}C$
Storage Temperature Range	T_{STG}	-60 to 150	$^{\circ}C$
Lead Temperature (Soldering, 10 s)	T_L	300	$^{\circ}C$

Stresses exceeding those listed in the Maximum Ratings table may damage the device. If any of these limits are exceeded, device functionality should not be assumed, damage may occur and reliability may be affected.

- $V_{CS/ZCD(MAX)}$ is the maximum voltage of the pin shown in the electrical table. When the voltage on this pin exceeds 7.4 V, the pin sinks a current equal to $[(V_{CS/ZCD} - 7.4 V) / 1 k\Omega]$. A $V_{CS/ZCD}$ of 9 V generates a sink current of approximately 1.6 mA.
- Maximum driver voltage is limited by the driver clamp voltage, $V_{DRV(high)}$, when V_{CC} exceeds the driver clamp voltage. Otherwise, the maximum driver voltage is V_{CC} .
- This device contains Latch-Up protection and has been tested per JEDEC Standard JESD78D, Class I and exceeds ± 100 mA.
- Low Conductivity Board. As mounted on 80 x 100 x 1.5 mm FR4 substrate with a single layer of 50 mm² of 2 oz copper trances and heat spreading area. As specified for a JEDEC51-1 conductivity test PCB. Test conditions were under natural convection of zero air flow.
- Pin 8 HV pin is ESD rated to 1200 V.

NCL30060

ELECTRICAL CHARACTERISTICS ($V_{CC} = 14\text{ V}$, $V_{HV} = 120\text{ V}$, $V_{FB} = 4\text{ V}$, $V_{CS/ZCD} = 0\text{ V}$, $C_{DRV} = 1\text{ nF}$, $R_T = 20\text{ k}\Omega$, for typical values $T_J = 25^\circ\text{C}$, for min/max values, T_J is -40°C to 105°C , unless otherwise noted)

Characteristic	Test Conditions	Symbol	Min	Typ	Max	Unit
STARTUP AND SUPPLY CIRCUITS						
Supply Voltage Startup Threshold Minimum Operating Voltage Operating Hysteresis Undervoltage Lockout Hysteresis Between $V_{CC(MIN)}$ and $V_{CC(UVLO)}$ Internal Latch/Logic Reset Level Transition from I_{start1} to I_{start2}	1 V/ms, V_{CC} increasing 1 V/ms, V_{CC} decreasing $V_{CC(on)} - V_{CC(MIN)}$ V_{CC} decreasing 1 V/ms, $V_{CC(min)} - V_{CC(UVLO)}$ V_{CC} decreasing V_{CC} increasing	$V_{CC(on)}$ $V_{CC(MIN)}$ $V_{CC(HYS1)}$ $V_{CC(UVLO)}$ $V_{CC(HYS2)}$ $V_{CC(reset)}$ $V_{CC(inhibit)}$	11.75 10.7 0.9 8.2 2.0 4.5 0.35	12.5 11.5 — 8 — 5.5 0.7	13.75 12.8 — 9.4 — 7.5 0.95	V
Supply Current In Fault Mode In Disable Modes Active Mode Without C_{DRV} , $f_{SW} = 60\text{ kHz}$ Active Mode With C_{DRV} , $f_{SW} = 60\text{ kHz}$	$V_{RT} = 0\text{ V}$ $C_{DRV} = \text{open}$ $C_{DRV} = 1\text{ nF}$	I_{CC1} I_{CC2} I_{CC4} I_{CC5}	140 300 800 1490	190 335 870 1600	240 450 975 1700	μA
Startup Current	$V_{CC} = 0\text{ V}$ to $V_{inhibit}$ $V_{HV} = 400\text{ V}$	I_{start1} I_{start2} I_{start3}	0.31 9 3.5	0.77 14 5.25	1.23 19 7.00	mA
V_{CC} Overvoltage Protection Threshold		$V_{CC(OVP)}$	27	28	29	V
V_{CC} Overvoltage Protection Delay		$t_{delay(V_{CC_OVP})}$	15	30	50	μs
Startup Circuit Off-State Leakage Current	$V_{HV} = 400\text{ V}$, $V_{CC} = V_{CC(on)}$ to $V_{CC(MAX)}$	$I_{HV(off)}$	—	24	30	μA
Minimum Startup Voltage	$I_{start2} = 1\text{ mA}$	$V_{HV(MIN)}$	—	—	40	V
Startup Current Transition Voltage Threshold	$I_{start3} = 5.25\text{ mA}$	$V_{HV(tran)}$	160	175	190	V
GATE DRIVE						
Rise Time (10–90%)	V_{DRV} from 10 to 90% of V_{DRV}	$t_{PDRV(rise)}$	—	80	180	ns
Fall Time (90–10%)	V_{DRV} from 90 to 10% of V_{DRV}	$t_{PDRV(fall)}$	—	40	80	ns
Current Capability Source Sink	$V_{DRV} = 2\text{ V}$ $V_{DRV} = 10\text{ V}$	$I_{DRV(SRC)}$ $I_{DRV(SNK)}$	— —	250 400	— —	mA
High State Voltage	$V_{CC} = V_{CC(UVLO)} + 0.2\text{ V}$, $R_{DRV} = 10\text{ k}\Omega$	$V_{DRV(highuvlo)}$	—	—	0.25	V
	$V_{CC} = V_{CC(OVP)} - 0.5\text{ V}$, $R_{DRV} = 10\text{ k}\Omega$	$V_{DRV(high)}$	10	12	14	V
Low State Voltage	$I_{DRV} = 100\mu\text{A}$	$V_{DRV(low)}$	—	—	0.25	V
FEEDBACK						
Feedback Open Voltage	$V_{FB} = \text{open}$	$V_{FB(open)}$	6.0	6.3	6.6	V
Minimum FB Voltage to Generate Drive Pulses	V_{FB} decreasing	$V_{FB(offset)}$	0.60	0.70	0.80	V
Feedback Bias Resistor		$R_{FB(bias)}$	20	25.8	29.6	k Ω
CONSTANT ON TIME GENERATOR						
On Time	$R_T = 20\text{ k}\Omega$, $V_{FB} = V_{FB(open)}$ $R_T = 10\text{ k}\Omega$, $V_{FB} = V_{FB(open)}$ $R_T = 80\text{ k}\Omega$, $V_{FB} = V_{FB(open)}$ $R_T = 80\text{ k}\Omega$, $V_{FB} = 4.45\text{ V}$ $R_T = 80\text{ k}\Omega$, $V_{FB} = 3.2\text{ V}$	t_{on1} t_{on2} t_{on3} t_{on4} t_{on5}	4.75 2.37 18.4 13.6 9.0	5.0 2.50 19.5 14.5 9.56	5.25 2.63 20.7 15.5 10.1	μs
Maximum On Time	$R_T = 110\text{ k}\Omega$ to open, $V_{FB} = V_{FB(open)}$	$t_{on(MAX)}$	22.0	27.5	33.0	μs

Product parametric performance is indicated in the Electrical Characteristics for the listed test conditions, unless otherwise noted. Product performance may not be indicated by the Electrical Characteristics if operated under different conditions.

NCL30060

ELECTRICAL CHARACTERISTICS ($V_{CC} = 14\text{ V}$, $V_{HV} = 120\text{ V}$, $V_{FB} = 4\text{ V}$, $V_{CS/ZCD} = 0\text{ V}$, $C_{DRV} = 1\text{ nF}$, $R_T = 20\text{ k}\Omega$, for typical values $T_J = 25^\circ\text{C}$, for min/max values, T_J is -40°C to 105°C , unless otherwise noted)

Characteristic	Test Conditions	Symbol	Min	Typ	Max	Unit
----------------	-----------------	--------	-----	-----	-----	------

CONSTANT ON TIME GENERATOR

Maximum On-Time Feedback Voltage	V_{FB} increasing	$V_{FB(tonMAX)}$	5.415	5.70	5.985	V
RT Pin Regulation Voltage		$V_{RT(REG)}$	–	2.0	–	V
On-Time Modulation Frequency		f_{MOD}	254	292	325	Hz
On Time Modulation		$t_{on(MOD)}$	± 4	± 6	± 8	%

DISABLE FUNCTION

RT Disable Current Threshold	I_{RT} Decreasing	$I_{RT(disable)}$	250	325	400	μA
RT Enable Threshold	V_{RT} increasing	$V_{RT(enable)}$	380	400	420	mV
RT Pull-Up Current In Disable Mode		$I_{RT(dis)}$	45	50	55	μA
Disable Blanking	I_{RT} increasing or $V_{Disable}$ decreasing	$t_{disable(blank)}$	6.8	8	9.8	μs

ZERO CURRENT DETECTION

ZCD Arming Threshold	$V_{CS/ZCD}$ Increasing	$V_{ZCD(ARM)}$	225	250	275	mV
ZCD Trigger Threshold	$V_{CS/ZCD}$ Decreasing	$V_{ZCD(TRIG)}$	35	55	90	mV
ZCD Arming Blanking Duration		$t_{ARM(blank)}$	1.7	2.05	2.35	μs
ZCD Propagation Delay	$V_{CS/ZCD}$ stepping from 2.0 V to 0 V, $dV/dt = 20\text{ V}/\mu\text{s}$, $V_{CS/ZCD} = V_{ZCD(TRIG)}$ to $V_{DRV} = 10\%$	$t_{ZCD(PROP)}$	–	150	170	ns
Input Voltage Excursion Upper Clamp Negative Clamp	$V_{CC} = 14\text{V}$, $I_{CS/ZCD} = 5\text{ mA}$ $V_{CC} = 14\text{V}$, $I_{CS/ZCD} = -2\text{ mA}$	$V_{CS/ZCD(MAX)}$ $V_{CS/ZCD(MIN)}$	– –0.9	12.4 –0.7	– 0	V
CS/ZCD Open Voltage		$V_{ZCD(open)}$	6.5	–	–	V
Pull-up Current Source		$I_{CS/ZCD}$	0.7	1.0	1.3	μA
Timeout After Last Demagnetization Detection	$V_{CS/ZCD} > V_{ILIM2}$	t_{off1} t_{off2}	100 1000	200 1250	300 1700	μs
Minimum ZCD Pulse Width	Between $V_{ZCD(rising)}$ and $V_{ZCD(falling)}$ to DRV	t_{SYNC}	–	70	200	ns

CURRENT SENSE

Current Sense Voltage Threshold	$T_J = 25^\circ\text{C}$ $T_J = -40^\circ\text{C}$ to 125°C	V_{ILIM1}	242.5 238	250 250	257.5 262	mV
Propagation Delay	Step $V_{CS/ZCD}$ 0 V to $V_{ILIM1} + 0.1\text{ V}$ to DRV falling edge,	t_{ILIM1}	–	100	200	ns
Leading Edge Blanking Duration	Step $V_{CS/ZCD}$ 0 V to $V_{ILIM1} + 0.1\text{ V}$ to DRV falling edge,	$t_{CS(LEB1)}$	250	325	400	ns
Abnormal Overcurrent Fault Threshold		V_{ILIM2}	475	500	525	mV
Fault Propagation Delay	Step $V_{CS/ZCD}$ 0 V to $V_{ILIM2} + 0.1\text{ V}$ to DRV falling edge,	t_{ILIM2}	–	125	175	ns
Fault Leading Edge Blanking Duration	Step $V_{CS/ZCD}$ 0 V to $V_{ILIM2} + 0.1\text{ V}$ to DRV falling edge,	$t_{CS(LEB2)}$	90	120	150	ns
Leading Edge Blanking Duration Ratio	$t_{LEB(LEB2)}/t_{LEB1}$	$t_{LEB(ratio)}$	–	0.37	–	–
Number of Consecutive Abnormal Current Events to Enter Fault Mode (Latch mode available on customer request)		n_{ILIM2}	–	4	–	

Product parametric performance is indicated in the Electrical Characteristics for the listed test conditions, unless otherwise noted. Product performance may not be indicated by the Electrical Characteristics if operated under different conditions.

NCL30060

ELECTRICAL CHARACTERISTICS ($V_{CC} = 14\text{ V}$, $V_{HV} = 120\text{ V}$, $V_{FB} = 4\text{ V}$, $V_{CS/ZCD} = 0\text{ V}$, $C_{DRV} = 1\text{ nF}$, $R_T = 20\text{ k}\Omega$, for typical values $T_J = 25^\circ\text{C}$, for min/max values, T_J is -40°C to 105°C , unless otherwise noted)

Characteristic	Test Conditions	Symbol	Min	Typ	Max	Unit
----------------	-----------------	--------	-----	-----	-----	------

OUTPUT SHORT CIRCUIT AND OVERVOLTAGE PROTECTION

Output Short Off-Time Detector Threshold	Detected during DRV low	$t_{off(OS)}$	43	50	55	μs
Output Short Detection Integration Weighting Ratio	$N_{INTRatio(OS)} = \frac{\text{Charging speed (Output Short detected)}}{\text{Discharging speed (normal operation)}}$	$N_{INTRatio(OS)}$		20		
Output Short Detection Integration Time for Continuous Integration pulses		$t_{INTCON(OS)}$	36.7	40	45.7	ms
Overvoltage Threshold	DRV is low	V_{OVP}	5.8	6.0	6.2	V
Overvoltage Propagation Delay	$V_{CS/ZCD} = 0\text{ V}$ to 7 V ramp, $dV/dt = 1\text{ V}/\mu\text{s}$, $V_{CS/ZCD} = V_{OVP}$ to DRV low	$t_{OVP(PROP)}$	–	–	2.5	μs
Overvoltage Blanking		$t_{OVP(blank)}$	1.5	2.0	2.5	μs
Number of Consecutive Overvoltage Events to Enter Fault Mode Mode (Latch mode available on customer request)		n_{OVP}	–	4	–	
Auto-recovery Timer Duration		$t_{autorecovery}$	0.8	1.0	1.2	s

System Startup Threshold		$V_{BO(start)}$	102	111	120	V
System Shutdown Threshold		$V_{BO(stop)}$	88	96	104	V
Brown-out Detection Blanking Time	V_{HV} decreasing, delay from $V_{BO(stop)}$ to drive disable	$t_{BO(stop)}$	43	54	65	ms

THERMAL PROTECTION

Thermal Shutdown	Temperature increasing	T_{SHDN}	–	160	–	$^\circ\text{C}$
Thermal Shutdown Hysteresis	Temperature decreasing	$T_{SHDN(HYS)}$	–	50	–	$^\circ\text{C}$

Product parametric performance is indicated in the Electrical Characteristics for the listed test conditions, unless otherwise noted. Product performance may not be indicated by the Electrical Characteristics if operated under different conditions.

DETAILED OPERATING DESCRIPTION

HIGH VOLTAGE STARTUP CIRCUIT

The NCL30060 integrates a 700 V startup regulator eliminating the need of external startup components. The startup regulator consists of a constant current source that supplies current from the high voltage input terminal (HV) to the supply capacitor on the VCC pin (C_{CC}). The startup circuit current (I_{start2}) and (I_{start3}) are disabled if the VCC pin is below $V_{CC(inhibit)}$. In this condition, the startup current is reduced to I_{start1} , typically 0.77 mA. In addition, this regulator reduces no load power and increases the system efficiency as it uses negligible power in the normal operation mode.

After VCC pin is higher than $V_{CC(inhibit)}$ threshold, the startup circuit uses I_{start3} to charge the VCC capacitor during the initial charging. I_{start3} has a typical value of 5.25 mA.

Once C_{CC} is charged to the startup threshold, $V_{CC(on)}$, typically 12.5 V, the startup regulator is disabled and the controller is enabled. The initial charging on VCC capacitor is done. The controller is then biased by the VCC capacitor.

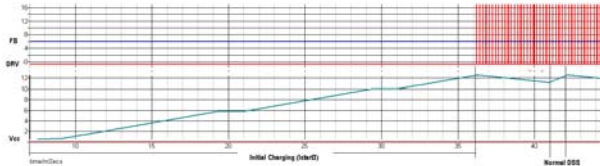

Figure 3. Initial Charging of VCC and Normal DSS

The startup regulator is enabled once VCC falls below its minimum operating threshold, $V_{CC(MIN)}$, typically 11.5 V. The driver continues operation while VCC is charged by the startup circuit. This operating mode is known as dynamic self supply or DSS. During normal DSS operation, the startup circuit uses I_{start2} to charge the VCC capacitor when the line voltage is below $V_{HV(tran)}$, and the startup circuit uses I_{start3} when the line voltage is higher than $V_{HV(tran)}$. $V_{HV(tran)}$ has a typical value of 175 V. Figure 3 shows the initial charging of VCC capacitor and normal DSS.

The startup circuit continues to charge VCC until the convertor bias winding is able to provide power to the VCC capacitor. As long as the bias winding can maintain the VCC voltage higher than $V_{CC(MIN)}$, the startup circuit will not be enabled. The startup circuit enters DSS mode if the VCC voltage is lower than $V_{CC(MIN)}$.

The increase in current consumption due to external gate charge is calculated using Equation 1.

$$I_{CC(gate\ charge)} = f \cdot Q_G \quad (eq. 1)$$

where f is the operating frequency and Q_G is the gate charge of the external MOSFETs. The additional gate charge current should not exceed the startup circuit. Otherwise, VCC will not charge to $V_{CC(on)}$ and may stay at an undetermined voltage while dissipating excessive power. The controller and the startup circuit are disabled if the junction temperature of the device exceeds the thermal shutdown threshold, T_{SHDN} , typically 160°C. The controller is disabled if VCC falls below the undervoltage lockout (UVLO) threshold, $V_{CC(UVLO)}$, typically 8.8 V. A noise filter, t_{UVLO} , 25 μ s maximum, blanks the UVLO fault before disabling the controller.

FEEDBACK INPUT

A signal proportional to the output error is applied to the FB pin by means of an optocoupler or other means such as an Op Amp. The PWM Comparator compares the feedback or error signal to a level shifted voltage ramp to control the power switch on-time. The feedback voltage is directly proportional to the output power. An internal pull up resistor, R_{FB} , drives this pin to provide more linear response from the optocoupler transistor. The voltage reference biasing R_{FB} is typically 6.3 V.

The minimum on-time, $t_{on(MIN)}$, is determined by the propagation delay of the PWM Comparator and control logic. It is limited below 200 ns. The minimum on-time is achieved when V_{FB} is right on the voltage offset of the On-time Ramp, $V_{FB(offset)}$. A V_{FB} below $V_{FB(offset)}$ results in no drive pulses or “zero” on-time.

The maximum on-time is limited by the Maximum On-time comparator. The comparator is enabled once the feedback voltage, V_{FB} , exceeds $V_{FB(tonMAX)}$. This establishes the point where the LED driver transitions from constant current feedback (if so configured) to primary power control.

MAXIMUM ON-TIME

The PWM Comparator controls the on-time by comparing an internal voltage ramp, $V_{on-time}$, to the feedback voltage. The internal ramp is generated by charging an internal capacitor with a fixed current source. The slope of the ramp is adjusted by the user using an external timing resistor, R_T , between the R_T and GND pins. The architecture of the on-time control circuitry is shown in Figure 4.

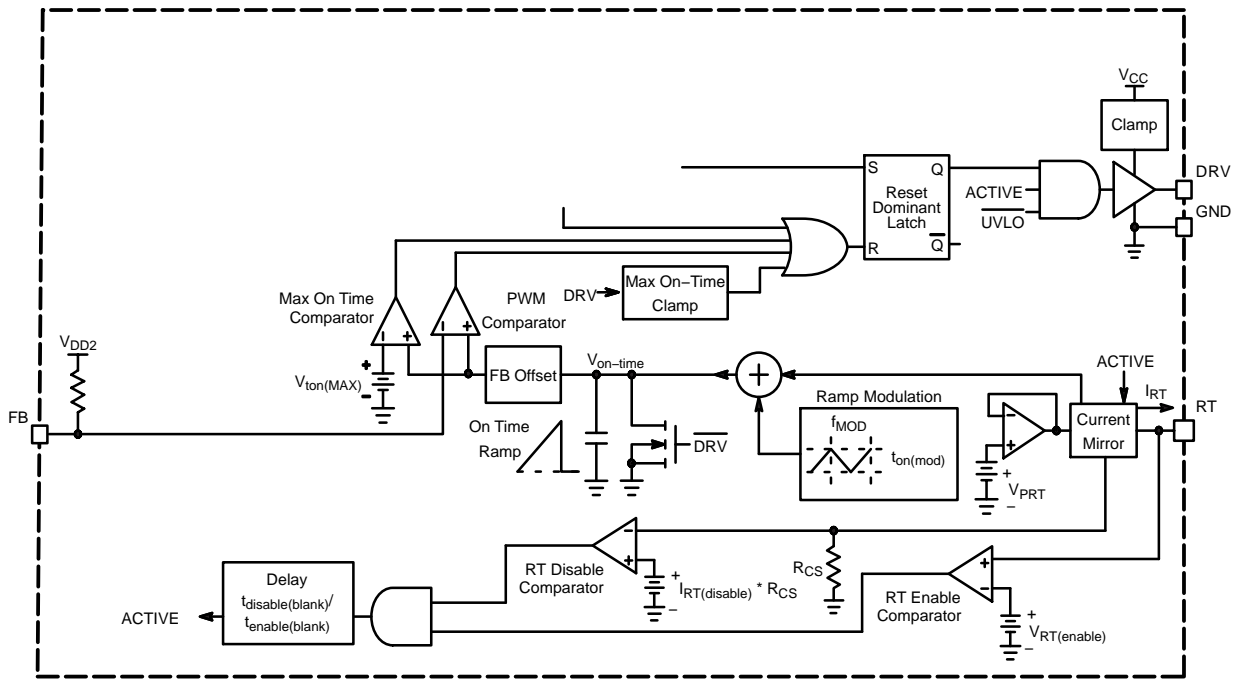

Figure 4. On-Time Control Architecture

The on-time is internally modulated to reduce the EMI signature of the controller. The modulation is accomplished by modulating the charge current using an internal triangle wave oscillator. The charge current is adjusted $\pm 6\%$ from the nominal value. The EMI signature of the controller is spread over a wide range of frequencies eliminating high peaks during an average reading.

The absolute maximum on-time determines the maximum power of the system. The NCL30060 accurately controls the maximum on-time of the system by the Max On-time Clamp circuits. It ensures that On-time can't exceed $t_{on(MAX)}$, typically $27.5 \mu s$, when the R_T resistor value is above $110 k\Omega$. There is also a fixed voltage reference, $V_{ton(MAX)}$, which defines the maximum effective V_{FB} voltage. Given a certain R_T value between $10 k\Omega$ and $110 k\Omega$, the Maximum On-time Comparator controls the on-time when primary side regulation is required. This could occur during an overload condition or during startup when the feedback signal is not present. The relationship between R_T and $t_{on(MAX)}$ is given by Equation 2 and Figure 5.

$$t_{on(MAX)} = 0.25 \cdot R_T \quad (\text{eq. 2})$$

Where $t_{on(MAX)}$ is in μs and R_T is in $k\Omega$.

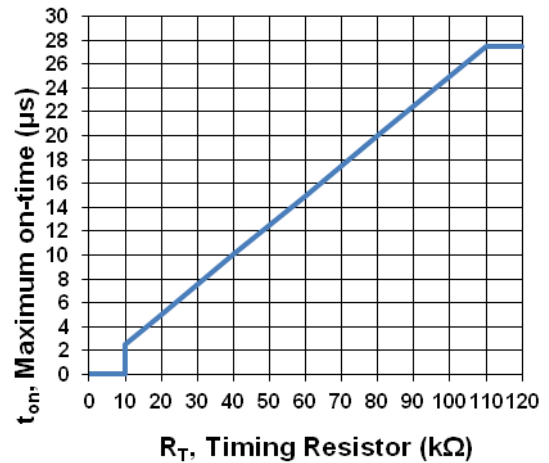

Figure 5. Maximum On-Time vs R_T

The R_T pin has a threshold output current of $I_{RT(disable)}$ which has a maximum value of $400 \mu A$. The maximum on-time is limited to $27.5 \mu s$ if the pin is left open or the R_t is higher than $110 k\Omega$. If the resistance between R_T pin and GND is small enough to make the R_t pin current higher than $I_{RT(disable)}$, the device is disabled after the blanking delay $t_{disable(blank)}$ and the R_T pin output current is switched to

NCL30060

$I_{RT(dis)}$ which has 50 μA typical value. After the device is disabled, the integrated HV source maintains V_{CC} above $V_{CC(min)}$. The IC is activated when the voltage of the RT pin is higher than the $V_{RT(enable)}$, which has typical value of 400 mV. And the RT pin output current is switched back to normal operation, and the RT voltage is regulated to $V_{RT(REG)}$, which has a typical value of 2 V.

The timing resistor should be placed as close as possible to the RT and GND pins with short trace lengths. Care should

be taken to keep switching nodes (high dv/dt) away from R_T to reduce noise pickup.

CURRENT SENSE, ZERO CURRENT AND OVERVOLTAGE DETECTION

The NCL30060 uses a novel architecture combining the current sense, the zero current detector (ZCD), output overvoltage and shorted output detector functions in a single terminal. Figure 6 shows the circuit schematic of the current sense and ZCD detectors.

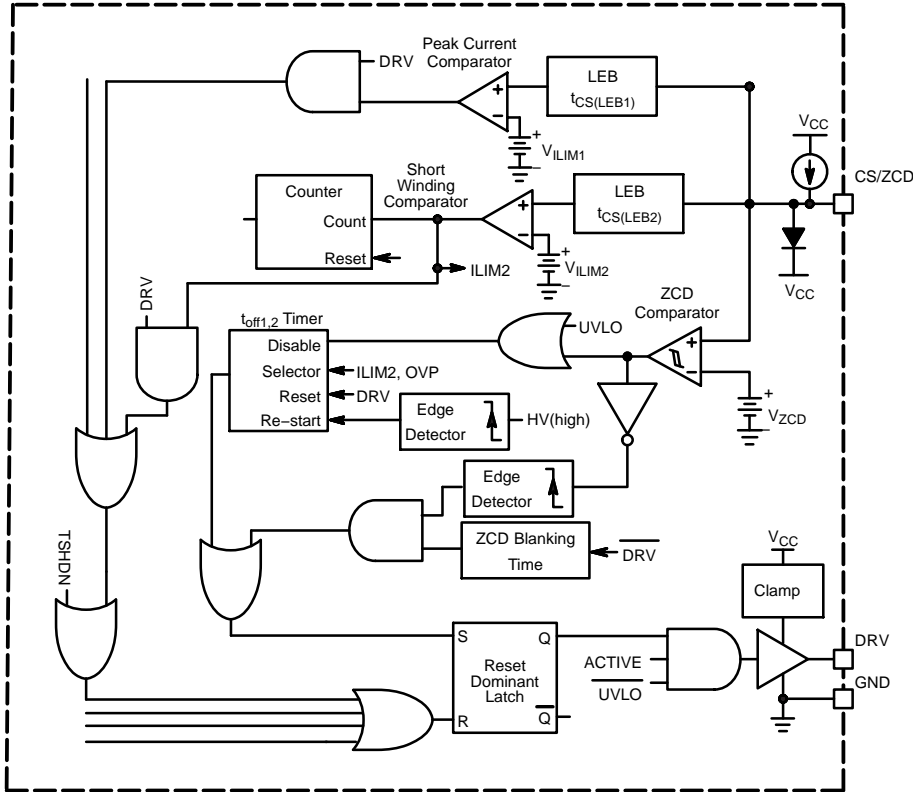

Figure 6. Current Sense and ZCD Detectors Schematic

CURRENT SENSE

The Switch current is sensed across a sense resistor, R_{sense} , and the resulting voltage ramp is applied to the CS/ZCD pin. The current signal is blanked by a leading edge blanking (LEB) circuit. The blanking period eliminates the leading edge spike and high frequency noise during the switch turn-on event. The LEB period, $t_{CS(LEB1)}$, is typically 325 ns. The Current Limit Comparator disables the driver once the current sense signal exceeds the current sense reference, V_{ILIM1} , typically 0.25 V. The next switching cycle is initiated by the ZCD or watchdog timer.

A severe overload fault like a secondary side winding short circuit causes the switch current to increase very rapidly during the on-time. The current sense signal significantly exceeds V_{ILIM1} . But, because the current sense signal is blanked by the LEB circuit during the switch turn on, the current could damage the system.

The NCL30060 protects against this fault by adding an additional comparator, Short Circuit Comparator. The current sense signal is blanked with a shorter LEB duration, $t_{CS(LEB2)}$, typically 125 ns, before applying it to the Short Circuit Comparator. The voltage threshold of the comparator, V_{ILIM2} , typically 0.5 V, is set twice the level of V_{ILIM1} , to avoid interference with normal operation. Four consecutive faults detected by the Short Circuit Comparator causes the controller to enter a fault mode. The NCL30060B will auto-recover from the fault state if the short is removed. The count to 4 provides noise immunity during surge testing. The counter is reset each time a DRV pulse occurs without activating the Short Circuit Comparator.

The watchdog timer duration (t_{off2}) is increased to 1.25 ms independent of the PFC ZCD state.

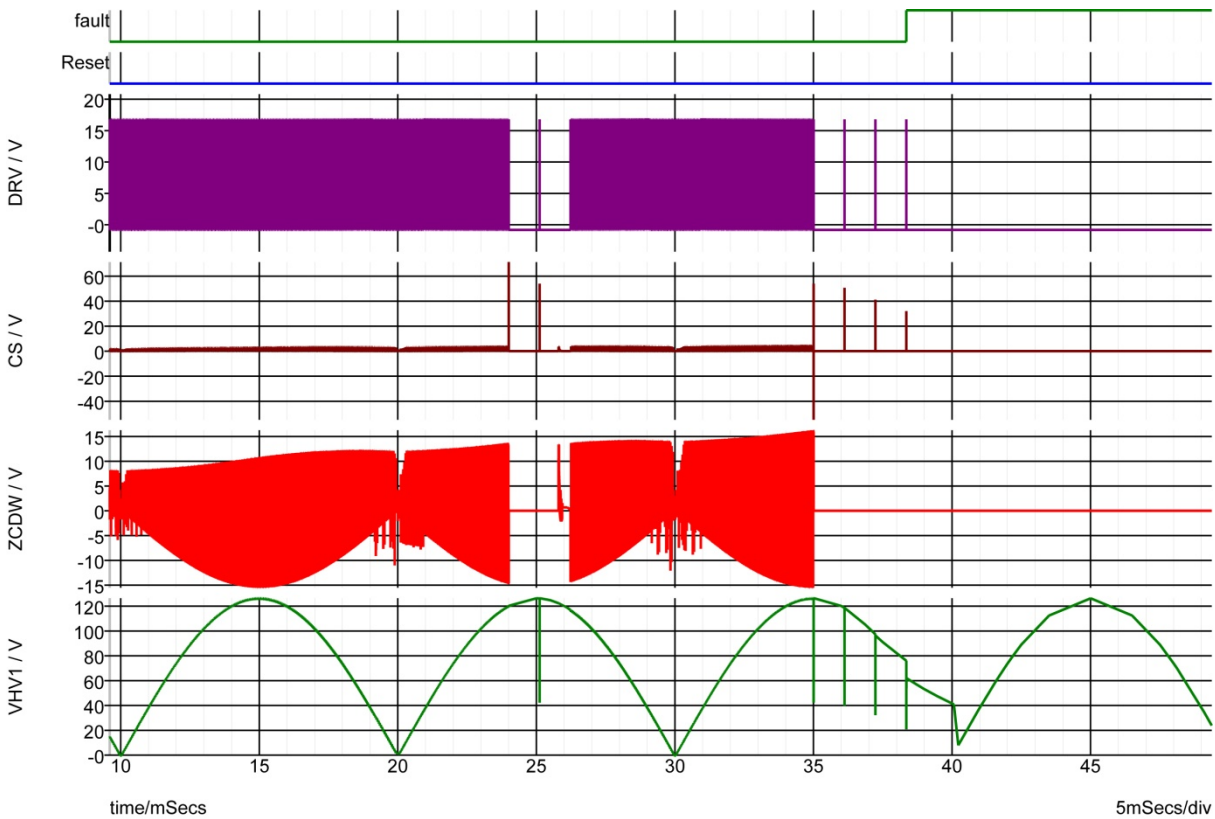

Figure 7. Secondary Side Winding Short-Circuit Waveforms

Figure 7 shows simulation results for an output winding short. The simulation waveforms are described below:

- ◆ DRV/V is gate drive signal for the PFC switch.
- ◆ VCS/V is the signal on the CS/ZCD pin.
- ◆ ZCDW/V is the voltage across the ZCD winding.
- ◆ VHV1/V is the voltage on the HV pin.

The converter is operating normally and a momentary fault is applied at 24 ms. Once the fault is applied, the watchdog timer duration increases to t_{off2} . The fault is removed after two faults overcurrent events are detected. The fault is re-applied at 35 ms. After four consecutive overcurrent conditions are detected, the fault signal goes high.

ZERO CURRENT DETECTION

The off-time in a CrM topology varies with the instantaneous line voltage and it is adjusted every cycle to allow the inductor current to reach zero before the next switch cycle begins. The inductor is demagnetized once its current reaches zero. Once the inductor is demagnetized the drain voltage of the switch begins to fall. The inductor demagnetization is detected by sensing the voltage across the inductor using an auxiliary winding. This winding is commonly known as a zero crossing detector (ZCD) winding. This winding provides a scaled version of the drain voltage. Figure 8 shows the ZCD winding arrangement.

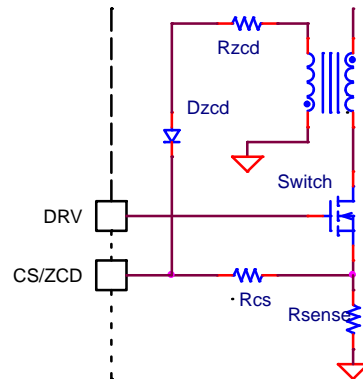

Figure 8. ZCD Winding Implementation

The ZCD voltage, $V_{CS/ZCD}$, is positive while the Switch is off and current flows on the secondary side. $V_{CS/ZCD}$ drops to and rings around zero volts once the transformer is demagnetized. The next switch cycle commences once a negative going transition is detected in the CS/ZCD pin. A positive transition (corresponding to the switch turn off) arms the ZCD detector to prevent false triggering. The arming of the ZCD detector, $V_{ZCD(ARM)}$, is typically 250 mV ($V_{CS/ZCD}$ increasing). The trigger threshold, $V_{ZCD(TRIG)}$, is typically 55 mV ($V_{CS/ZCD}$ decreasing).

The NCL30060 incorporates a minimum off-time delay, $t_{ARM(blank)}$, typically $2.0 \mu s$. This delay blanks the ringing which may be present on the bias winding during start up or if the output of the converter is shorted. The next DRV pulse is initiated once $t_{ARM(blank)}$ expires if a ZCD transition is detected prior to the delay expiring. Otherwise, it will initiate on the ZCD transition after $t_{ARM(blank)}$ expires. In the absence of a ZCD transition, the watchdog timer initiates the next drive pulse.

The CS/ZCD pin is internally clamped to V_{CC} thru an internal diode. A 7.4 V Zener diode with a 1 k Ω resistor to GND also clamp the pin. A resistor in series with the CS/ZCD pin is required to limit the current into pin. The Zener diode also prevents the voltage from going below ground. Figure 9 shows typical ZCD waveforms.

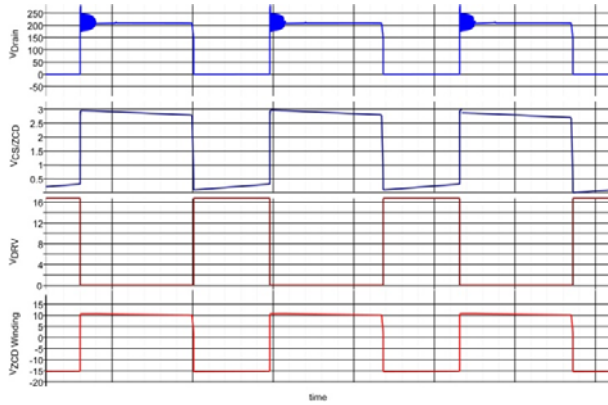

Figure 9. ZCD Winding Waveforms

During startup there are no ZCD transitions to set the PWM Latch and generate a DRV pulse. A watchdog timer, t_{off1} , starts the drive pulses in the absence of ZCD transitions. Its duration is typically $200 \mu s$. The timer is also useful during startup and while operating at light load because the amplitude of the ZCD signal may be very small to cross the ZCD thresholds. The watchdog timer is reset at the beginning of a drive pulse. It is disabled if the CS/ZCD pin is above the ZCD arming threshold.

The watchdog timer duration increases to t_{off2} , typically 1.25 ms, when a V_{ILIM2} fault is detected.

OVERVOLTAGE PROTECTION

Output overvoltage protection (OVP) is provided by monitoring the CS/ZCD pin during the off-time. A dedicated comparator compares the voltage on CS/ZCD pin to an internal reference, V_{OVB} , typically 6 V. If 4 consecutive OVP events are detected the controller enters a fault mode. A $2 \mu s$ blanking delay, $t_{OVP(blank)}$, blanks the signal CS/ZCD signal after the drive turns off to blank ringing generated by system parasitics. The blanking provides protection during power up and steady state operation. Figure 10 shows the

controller shutting down after an overvoltage condition is detected.

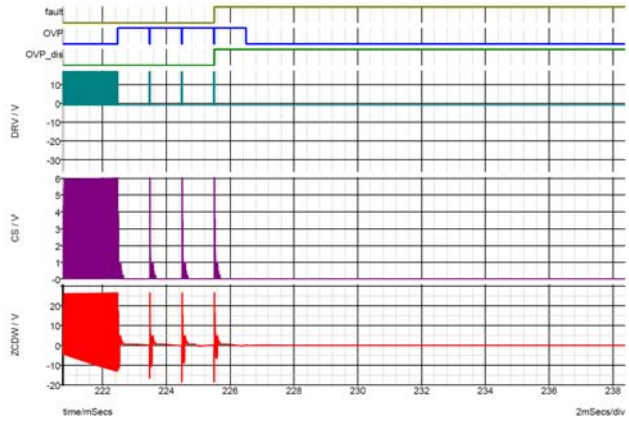

Figure 10. Overvoltage Detection Operating Waveforms

OUTPUT SHORT CIRCUIT DETECTION

When the converter is operating with low output voltage, the off-time is extended in CrM operation. In Figure 11 of the output short detection function block, the maximum off-time detector signals when the off time is longer than $50 \mu s$. This $50 \mu s$ off time detection triggers a $150 \mu s$ pulse to feed the integrator. The integrator has a weighted integration feature, which makes the charging 20 times faster than the discharging. A continuous stream of $150 \mu s$ pulses will reach the integrator threshold in 40ms. Periods of time without triggering the $150 \mu s$ timer will extend the time to reach the threshold. The integrator discharges as the relative number of $150 \mu s$ pulses over time decreases.

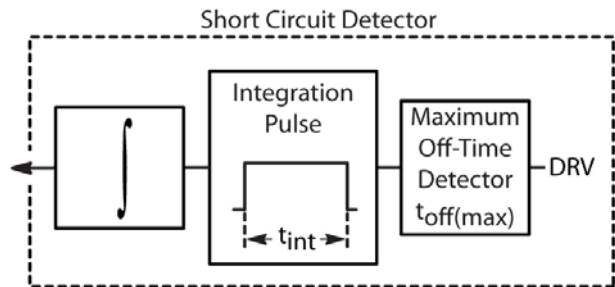

Figure 11. Output Short-Circuit Detector

When the threshold is reached, the system will determine there is an output short event. The system enters into fault mode. The NCL30060B will try to auto-recover after a 1 sec typical delay. This minimizes system power consumption due to the output short event. Figure 12 shows auto-restart operating waveforms.

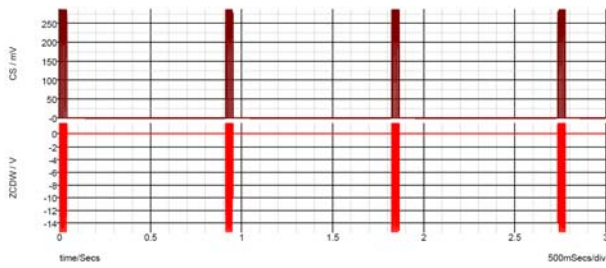

Figure 12. Output Short Detection and Protection Waveform

BROWN OUT DETECTION

The NCL30060 includes brown out protection providing a defined shutdown for low input voltage. This feature is enabled after a V_{CC} reset event and does not allow the controller to enter Active mode until the input voltage is above the startup threshold, typically 111 V.

If the input voltage remains below the system shutdown threshold, typically 96 V, longer than the brown out detection blanking time, typically 54 ms, a shutdown flag is set. Gate drive pulses will continue to be issued until the input voltage is near the ac line voltage zero crossing. When a zero crossing is detected and the flag is set, gate drive pulses cease thereby stopping power delivery to the LED load. The brown out flag remains set and switching is suspended until the input voltage rises above the startup threshold.

Delaying termination of gate drive pulses until the zero crossing ensures the system is at a low power state before shutting down. This approach avoids a situation where energy stored in the input filter may artificially force the sensed voltage to cross the startup threshold if switching is abruptly terminated. A false startup level would be followed by crossing the shutdown threshold again. Such cycling on and off near the brown out threshold would result in LED

flicker. Allowing the energy to discharge naturally near the zero crossing provides a clean brown out shutdown.

MOSFET DRIVER

The NCL30060 maximum supply voltage, $V_{CC(OVP)}$, is 28 V. Typical high voltage MOSFETs have a maximum gate voltage rating of 20 V. The driver incorporates an active voltage clamp to limit the gate voltage on the external MOSFET. The voltage clamp, $V_{DRV(high)}$, is typically 12 V with a maximum limit of 14 V.

AUTO-RECOVERY

The controller is disabled and enters a fault mode if V_{CC} drops below $V_{CC(UVLO)}$ or a non-latching fault is detected. The controller auto-restarts after the auto-recovery timer $t_{autorecovery}$, expires, typically 1 s.

THERMAL SHUTDOWN

An internal thermal shutdown circuit monitors the junction temperature of the IC. The controller including the startup circuit is disabled if the junction temperature exceeds the thermal shutdown threshold, T_{SHDN} , typically 150 °C. Once a thermal shutdown condition is validated, the startup circuit is disabled. The startup circuit is enabled once V_{CC} falls below $V_{CC(reset)}$, charging V_{CC} up to $V_{CC(on)}$. The controller remains disabled if the thermal shutdown is present upon reaching $V_{CC(on)}$. The controller restarts at the next $V_{CC(on)}$ once the IC temperature drops below T_{SHDN} by the thermal shutdown hysteresis, $T_{SHDN(HYS)}$, typically 40°C.

LAYOUT CONSIDERATIONS

The GND pin is the reference point for the controller. Unless specified otherwise, all measurements are made relative to this pin. Both power and control circuits use this reference. It is recommended to have short traces between this pin and control components to reduce parasitic inductance.

ORDERING INFORMATION

Ordering Part No.	OCF	Brown Out	Package	Shipping†
NCL30060ADR2G*	Latched	Enabled	SOIC-7 (Pb-Free)	2500 / Tape & Reel
NCL30060BDR2G	Auto-recoverable	Enabled		
NCL30060B1DR2G*	Auto-recoverable	Disabled		

†For information on tape and reel specifications, including part orientation and tape sizes, please refer to our Tape and Reel Packaging Specifications Brochure, BRD8011/D.

*Version available only by customer request.

NCL30060

PACKAGE DIMENSIONS

SOIC-7 CASE 751U ISSUE E

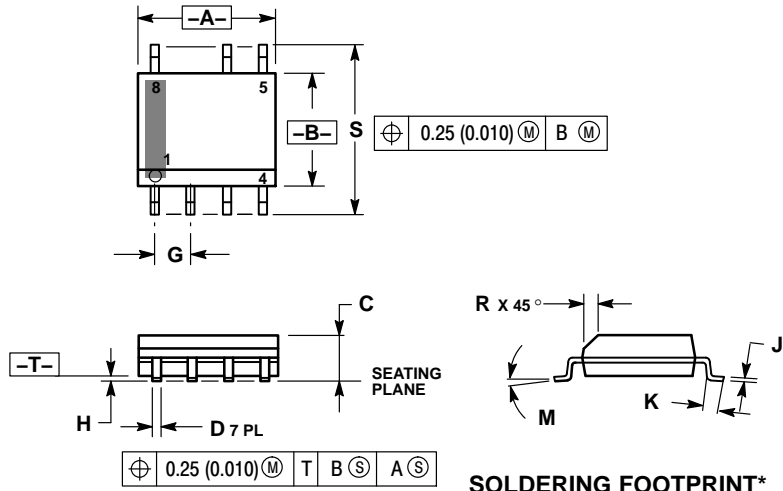

NOTES:

1. DIMENSIONING AND TOLERANCING PER ANSI Y14.5M, 1982.
2. CONTROLLING DIMENSION: MILLIMETER.
3. DIMENSION A AND B ARE DATUMS AND T IS A DATUM SURFACE.
4. DIMENSION A AND B DO NOT INCLUDE MOLD PROTRUSION.
5. MAXIMUM MOLD PROTRUSION 0.15 (0.006) PER SIDE.

DIM	MILLIMETERS		INCHES	
	MIN	MAX	MIN	MAX
A	4.80	5.00	0.189	0.197
B	3.80	4.00	0.150	0.157
C	1.35	1.75	0.053	0.069
D	0.33	0.51	0.013	0.020
G	1.27 BSC		0.050 BSC	
H	0.10	0.25	0.004	0.010
J	0.19	0.25	0.007	0.010
K	0.40	1.27	0.016	0.050
M	0°	8°	0°	8°
N	0.25	0.50	0.010	0.020
S	5.80	6.20	0.228	0.244

SOLDERING FOOTPRINT*

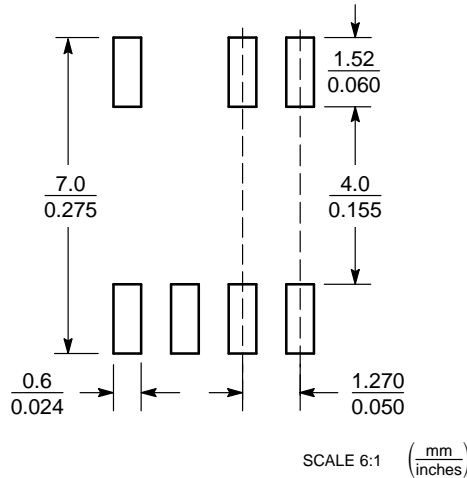

*For additional information on our Pb-Free strategy and soldering details, please download the ON Semiconductor Soldering and Mounting Techniques Reference Manual, SOLDERRM/D.

ON Semiconductor and are registered trademarks of Semiconductor Components Industries, LLC (SCILLC). SCILLC owns the rights to a number of patents, trademarks, copyrights, trade secrets, and other intellectual property. A listing of SCILLC's product/patent coverage may be accessed at www.onsemi.com/site/pdf/Patent-Marking.pdf. SCILLC reserves the right to make changes without further notice to any products herein. SCILLC makes no warranty, representation or guarantee regarding the suitability of its products for any particular purpose, nor does SCILLC assume any liability arising out of the application or use of any product or circuit, and specifically disclaims any and all liability, including without limitation special, consequential or incidental damages. "Typical" parameters which may be provided in SCILLC data sheets and/or specifications can and do vary in different applications and actual performance may vary over time. All operating parameters, including "Typicals" must be validated for each customer application by customer's technical experts. SCILLC does not convey any license under its patent rights nor the rights of others. SCILLC products are not designed, intended, or authorized for use as components in systems intended for surgical implant into the body, or other applications intended to support or sustain life, or for any other application in which the failure of the SCILLC product could create a situation where personal injury or death may occur. Should Buyer purchase or use SCILLC products for any such unintended or unauthorized application, Buyer shall indemnify and hold SCILLC and its officers, employees, subsidiaries, affiliates, and distributors harmless against all claims, costs, damages, and expenses, and reasonable attorney fees arising out of, directly or indirectly, any claim of personal injury or death associated with such unintended or unauthorized use, even if such claim alleges that SCILLC was negligent regarding the design or manufacture of the part. SCILLC is an Equal Opportunity/Affirmative Action Employer. This literature is subject to all applicable copyright laws and is not for resale in any manner.

PUBLICATION ORDERING INFORMATION

LITERATURE FULFILLMENT:
Literature Distribution Center for ON Semiconductor
P.O. Box 5163, Denver, Colorado 80217 USA
Phone: 303-675-2175 or 800-344-3860 Toll Free USA/Canada
Fax: 303-675-2176 or 800-344-3867 Toll Free USA/Canada
Email: orderlit@onsemi.com

N. American Technical Support: 800-282-9855 Toll Free
USA/Canada
Europe, Middle East and Africa Technical Support:
Phone: 421 33 790 2910
Japan Customer Focus Center
Phone: 81-3-5817-1050

ON Semiconductor Website: www.onsemi.com
Order Literature: <http://www.onsemi.com/orderlit>
For additional information, please contact your local Sales Representative



Компания «ЭлектроПласт» предлагает заключение долгосрочных отношений при поставках импортных электронных компонентов на взаимовыгодных условиях!

Наши преимущества:

- Оперативные поставки широкого спектра электронных компонентов отечественного и импортного производства напрямую от производителей и с крупнейших мировых складов;
- Поставка более 17-ти миллионов наименований электронных компонентов;
- Поставка сложных, дефицитных, либо снятых с производства позиций;
- Оперативные сроки поставки под заказ (от 5 рабочих дней);
- Экспресс доставка в любую точку России;
- Техническая поддержка проекта, помощь в подборе аналогов, поставка прототипов;
- Система менеджмента качества сертифицирована по Международному стандарту ISO 9001;
- Лицензия ФСБ на осуществление работ с использованием сведений, составляющих государственную тайну;
- Поставка специализированных компонентов (Xilinx, Altera, Analog Devices, Intersil, Interpoint, Microsemi, Aeroflex, Peregrine, Syfer, Eurofarad, Texas Instrument, Miteq, Cobham, E2V, MA-COM, Hittite, Mini-Circuits, General Dynamics и др.);

Помимо этого, одним из направлений компании «ЭлектроПласт» является направление «Источники питания». Мы предлагаем Вам помощь Конструкторского отдела:

- Подбор оптимального решения, техническое обоснование при выборе компонента;
- Подбор аналогов;
- Консультации по применению компонента;
- Поставка образцов и прототипов;
- Техническая поддержка проекта;
- Защита от снятия компонента с производства.



Как с нами связаться

Телефон: 8 (812) 309 58 32 (многоканальный)

Факс: 8 (812) 320-02-42

Электронная почта: org@eplast1.ru

Адрес: 198099, г. Санкт-Петербург, ул. Калинина, дом 2, корпус 4, литера А.