

Helping Customers Innovate, Improve & Grow



PX-700

### Features

- 5X7mm Surface Mount Package
- Frequency Range: 1 MHz to 800 MHz
- AC MOS, TTL, LVPECL and LVDS
- Wide operating temperature range -55°C to +125°C
- MIL-PRF-55310 Class B Screening (optional)
- Reflow Process Compatible
- Fully RoHS compliant \*
- ECCN: EAR99
- COO: USA
- Previous Model: C1250

\* ( Except parts with Sn-Pb Solder Coated Option )



### Applications

- Military Systems
- Avionics and Instrumentation
- Test Equipment
- Medical Equipment

### Performance Specifications

Frequency Stabilities <sup>1</sup>					
Parameter	Min	Typ	Max	Units	Condition
vs. operating temperature range (Referenced to +25°C)	-15 -25 -50 -65 -80 -100		+15 +25 +50 +65 +80 +100	ppm ppm ppm ppm ppm ppm	(See Table I under ordering information)
Initial tolerance	-15 -25 -50 -65 -80 -100		+15 +25 +50 +65 +80 +100	ppm ppm ppm ppm ppm ppm	@+25°C
Overall tolerance (Referenced to +25°C)  (Included operation temperature and initial accuracy)	-25 -50 -65 -80 -100		+25 +50 +65 +80 +100	ppm ppm ppm ppm ppm	(See Table II under ordering information)
vs. supply voltage change vs. load change vs. aging / 1 year vs. aging / year (following years)	-2 -1 -3 -1		+2 +1 +3 +1	ppm ppm ppm ppm	VS ± 5% Load ± 5% after 30 days of operation

# Performance Specifications

Supply Voltage (Vs)					
Parameter	Min	Typ	Max	units	Condition
Supply voltage	4.75	5.0	5.25	VDC	
Supply voltage	3.135	3.3	3.465	VDC	
Supply voltage	2.375	2.5	2.625	VDC	
Current consumption * No load (+5 VDC)			15 20 40	mA mA mA	ACMOS or TTL 1.0 to 23.9 MHz ACMOS or TTL 24 to 49.9 MHz ACMOS or TTL 50 to 125.00 MHz
Current consumption * No load (+3.3 VDC or +2.5 VDC)			6 8 16 20 40 75 100	mA mA mA mA mA mA mA	ACMOS 1.0 to 14.9 MHz ACMOS 15.0 to 39.9 MHz ACMOS 40.0 to 59.9 MHz ACMOS 60.0 to 84.9 MHz ACMOS 85.0 to 125.0 MHz LVPECL or LVDS <200 MHz LVPECL or LVDS >200 MHz
Current consumption * No load (+1.8 VDC)			1.5 2.0 8.0	mA mA mA	ACMOS 1.0 to 14.9 MHz ACMOS 15.0 to 49.9 MHz ACMOS 50.0 to 100 MHz

RF Output					
Parameter	Min	Typ	Max	Units	Condition
Signal	<b>ACMOS</b>				
Load		15		pF	
Signal Level (Vol)			0.5 0.3 0.25	VDC VDC VDC	with Vs=5.0V and 15pF load with Vs=3.3V and 15pF load with Vs= 2.5V and 15pF load
Signal Level (Voh)	4.5 3.0 2.25			VDC VDC VDC	with Vs=5.0V and 15pF load with Vs=3.3V and 15pF load with Vs=2.5V and 15pF load
Rise and fall times for ACMOS (measured 10% to 90%)			10 6 3	ns ns ns	1.0 to 23.9 MHz 24.0 to 79.9 MHz 80.0 to 125.0 MHz
Duty cycle	45 40		55 60	% %	@ 50% Vs< 15 MHz @ 50% Vs=> 15 MHz
Signal	<b>TTL</b>				
Load			10	TTL	Freq < 60MHz , 6 TTL > 60 MHz
Signal Level (Vol)			0.4	V	
Signal Level (Voh)	+2.4			V	
Rise and fall times for ACMOS (measured 20% to 80%)			15 5	ns ns	@ (0.5-2.4V), <= 20MHz @ (0.5-2.4V, > 20 MHz)
Duty cycle	45 40		55 60	% %	@ +1.5V, < 4 MHz @ +1.5V, >= 4 MHz
Signal	<b>LVPECL</b>				
Load			50	ohm	into Vcc-2V or Thevenin Equivalent
Signal Level (Vol)			Vs -1.62	VDC	-40....+85°C operating temp
Signal Level (Voh)	Vs- 1.025			VDC	-40....+85°C operating temp
Rise and fall times for ACMOS (measured 20% to 80%)			1000 600	ps ps	< 100 MHz >= 100 MHz
Duty Cycle	45		55	%	@ 50% Vdd
Jitter (rms)			10 0.5	ps ps	BW = 10Hz to 20 MHz BW = 12KHz to 20 MHz
Period Jitter (pk-pk)			40	ps	10,000 Samples - Rising edge

Parameter	Min	Typ	Max	Units	Condition
Signal	<b>LVDS</b>				
Load	60	100	140	ohm	Between outputs
Signal Level (Vol)		1.2		VDC	
Signal Level (Voh)		1.4		VDC	
Differential Voltage (Vod)	240	330	460	mVpeak	
Common Mode (Offset) Voltage (Vos)	1.125	1.2	1.375	V	
Start-up Time			10	ms	
Rise \ Fall Time		600	1000	ps	measured @ 20% to 80% of Vod
Duty cycle	45		55	%	@ 50% of Vod
Jitter (rms)			5 1	ps ps	BW = 10Hz to 20 MHz BW = 12KHz to 20 MHz
Period Jitter (pk-pk)			40	ps	10,000 Samples - Rising edge
<b>Absolute Maximum Ratings</b>					
Supply voltage (Vs)			7.0	V	with Vs=5.0VDC and 3.3 VDC
Operable temperature range	-55		+125	°C	
Storage temperature range	-62		+125	°C	

<b>Additional Parameters</b>		
Screening	Vectron Verification	
	Class B, MIL-PRF-55310, Rev.E	
Output Enable	Logic "0" input = Outputs disabled (Tri-state) Logic "1" or fl oating input = Outputs enabled	
	Logic "0" or fl oating input = Outputs enabled Logic "1" input = Outputs disabled (Tri-state)	
Weight	< 2 grams	
Processing & Packing	Handling & processing note	

<b>Standard Environmentals</b>	
Vibration	MIL-STD-202, Method 204, Condition G (30 G, 10Hz-2000Hz)
Shock	MIL-STD-202, Method 213, Condition I (100 G, 6ms, Sawtooth)
Acceleration	MIL-STD-883, Method 2001, Condition A (5000 G, Y1 Plane)
Temperature Cycling	MIL-STD-883, Method 1010, Condition B
Thermal Shock	MIL-STD-202, Method 107, Condition B
Solderability	MIL-STD-202, Method 208
Leak Test (Fine and Gross)	MIL-STD-883, Method 1014, Condition A1 and C1

## Outline Drawing / Enclosure

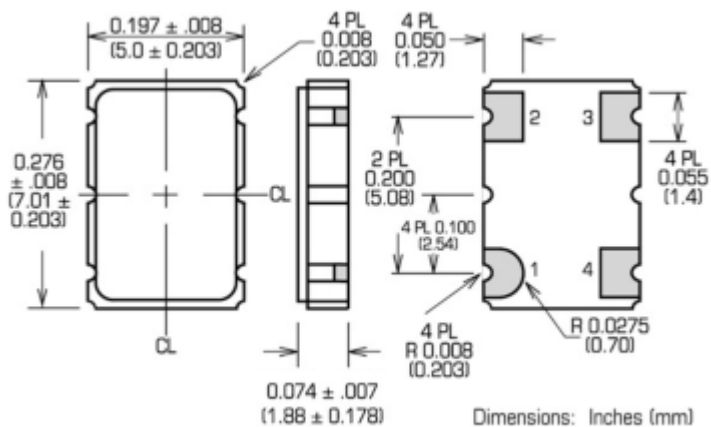

Type LCC (ACMOS or TTL)	
Package Code	Height "H"
0	1.88mm

Pin Connections	
1	Enable/Disable or N/C
2	Ground (Case)
3	Output
4	Supply

Note: Overall package thickness tolerance will be increases from +/- .007 to +/- .015 when I/O pads are solder coated.

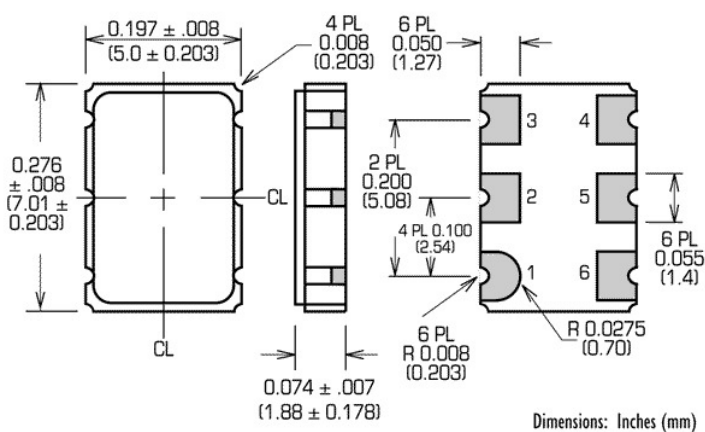

Type LCC (LVPECL or LVDS)	
Package Code	Height "H"
1	1.88mm

Pin Connections	
1	Enable/Disable or N/C
2	Enable/Disable or N/C (custom number required)
3	Ground (Case)
4	Output
5	Complementary Output
6	Supply

Note: Overall package thickness tolerance will be increases from +/- .007 to +/- .015 when I/O pads are solder coated.

## Outline Drawing / Enclosure

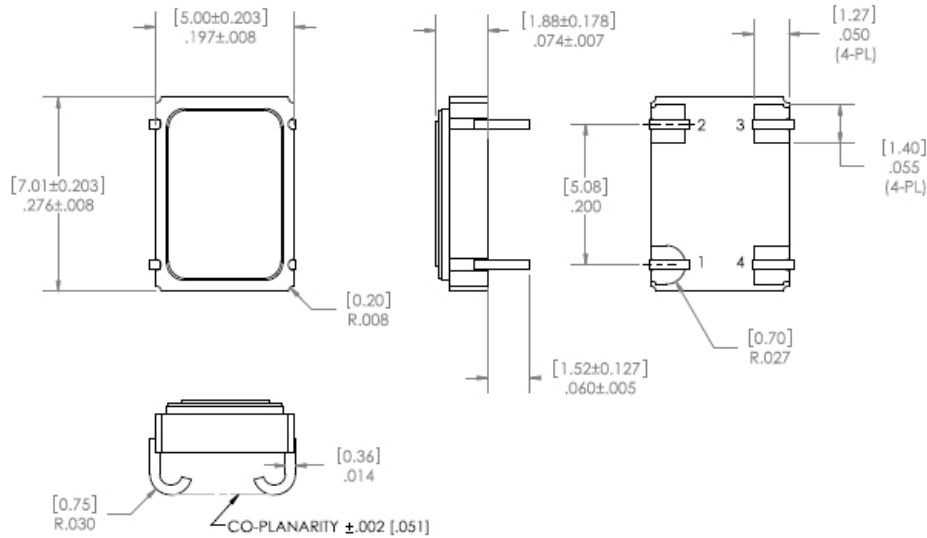

J-Leads are tinned with Alpha Sn/Pb 63/37 solder.

Type J-Leads (ACMOS or TTL)	
Package Code	Height "H"
2	3.40 mm

Pin Connections	
1	Enable/Disable or N/C
2	Ground (Case)
3	RF Output
4	Supply Voltage

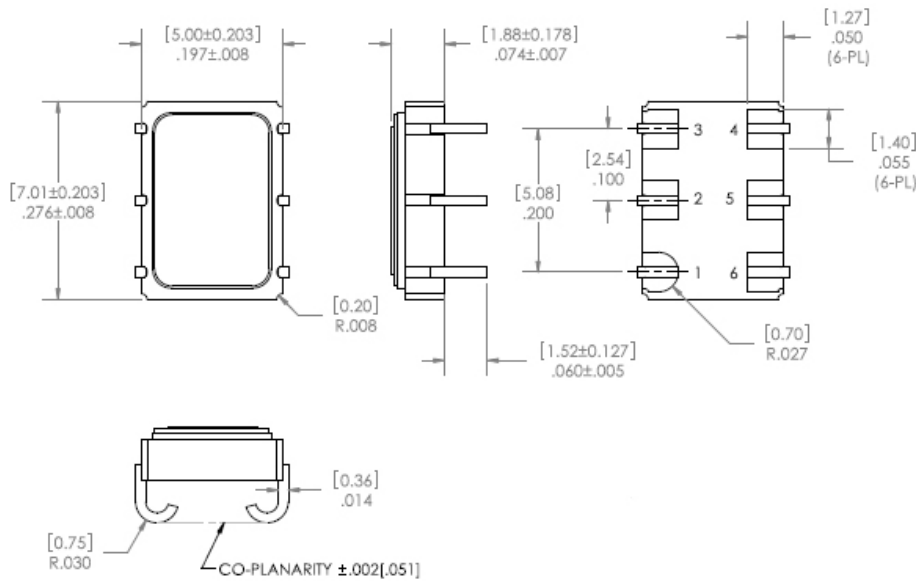

J-Leads are tinned with Alpha Sn/Pb 63/37 solder.

Type J-Leads (LVPECL or LVDS)	
Package Code	Height "H"
3	3.40 mm

Pin Connections	
1	Enable/Disable or N/C
2	N/C
3	Ground (Case)
4	RF Output
5	Complementary Output
6	Supply Voltage

## Recommended Reflow Profiles for Pb-Free & Sn-Pb

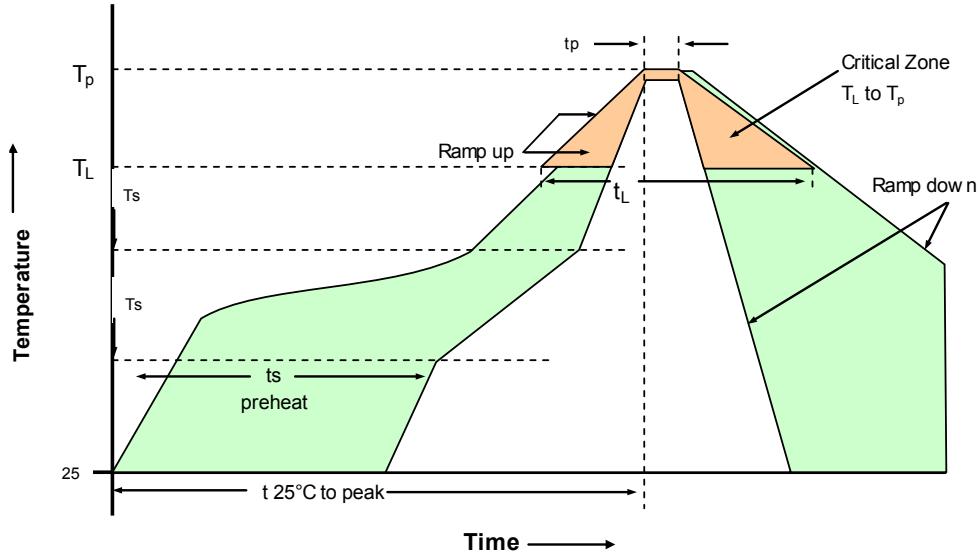

### 230°C Reflow Profile

Profile Feature	Sn-Pb Assembly	Profile Feature	Sn-Pb Assembly
Average ramp-up rate (TL to TP)	3°C/second max.	Time 25°C to Peak Temperature	4 minutes max.
Preheat - Temperature min T <sub>min</sub>	135°C	Time maintained above	
- Temperature Min T <sub>max</sub>	155°C	- Temperature (TL)	183°C
- Time (min to max) (ts)	60-90 seconds	- Time (tL)	45-60 seconds
T <sub>max</sub> to TL -Ramp-up Rate	3°C/second max.		
Time maintained above - Temperature (TL)	183°C	Time within 5°C of actual	10-20 seconds max.
- Time (TL)	40-60 seconds	Peak Temperature (tp)	
Peak Temperature (Tp)	max 230°C	Ramp-down Rate	6°C/second max.

**Note:** All temperatures refer to topside of the package, measured on the package body surface.

### 260°C Reflow Profile

Profile Feature	Pb-Free Assembly	Profile Feature	Pb-Free Assembly
Average ramp-up rate (TL to TP)	3°C/second max.	Time 25°C to Peak Temperature	8 minutes max.
Preheat - Temperature min T <sub>min</sub>	150°C	Time maintained above	
- Temperature min T <sub>max</sub>	200°C	- Temperature (TL)	217°C
- Time (min to max) (ts)	60-180 seconds	- Time (tL)	60-150 seconds
T <sub>max</sub> to TL -Ramp-up Rate	3°C/second max.		
Time maintained above - Temperature (TL)	217°C	Time within 5°C of actual	20-40 seconds max.
- Time (TL)	60-150 seconds	Peak Temperature (tp)	
Peak Temperature (Tp)	max 260°C	Ramp-down Rate	6°C/second max.

**Note:** All temperatures refer to topside of the package, measured on the package body surface.

# Ordering Information

## PX - 700 0 - D A T - F K X B - 10M000000

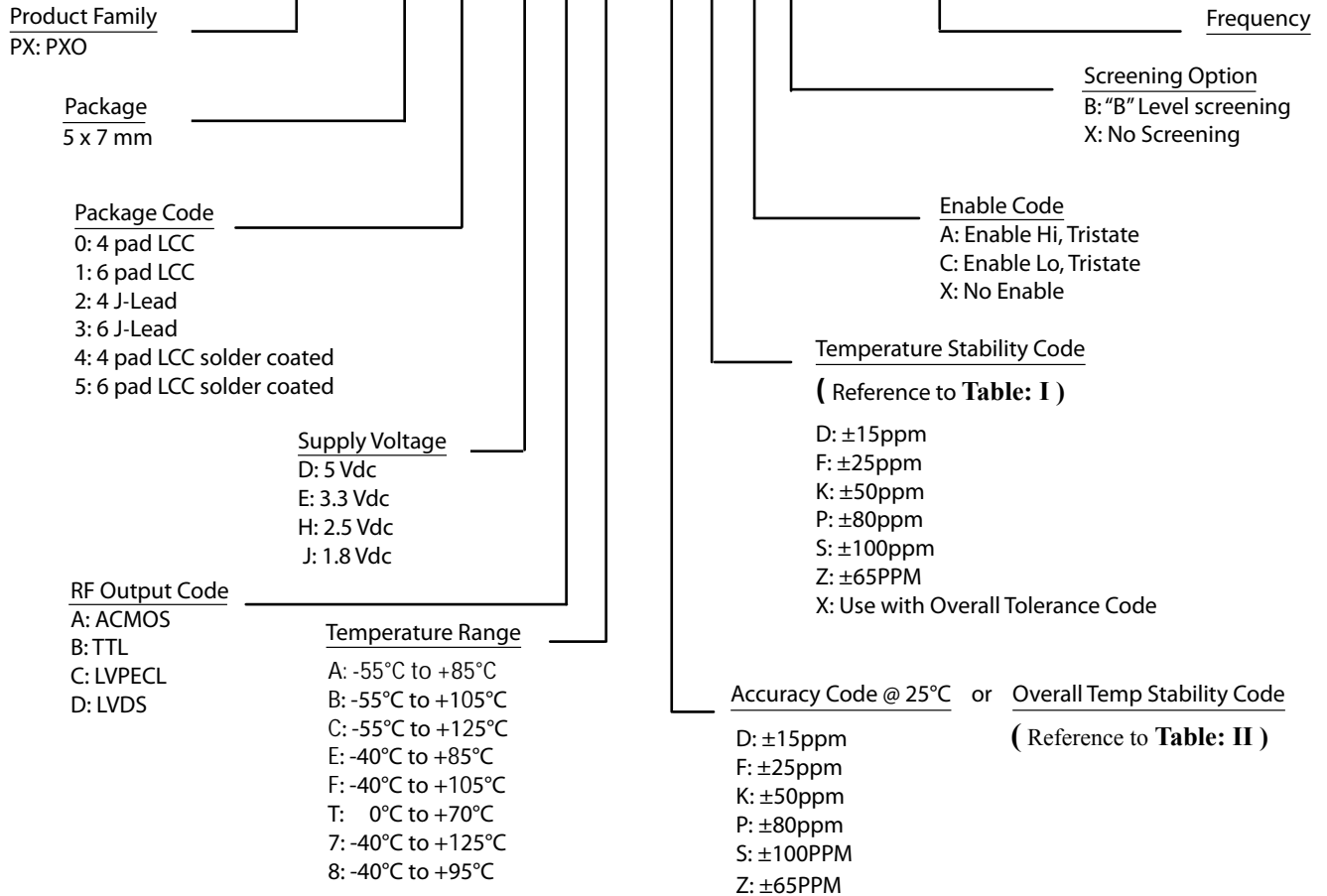

Available Temperature Stability Code	
Temp Range	Temp Stability
B: -55°C to +105°C C: -55°C to +125°C F: -40°C to +105°C 7: -40°C to +125°C	K: ± 50ppm
	Z ± 65ppm
	P ± 80ppm
	S ± 100ppm
A: -55°C to +85°C E: -40°C to +85°C 8: -40°C to +95°C	F: ± 25ppm
	K: ± 50ppm
	Z ± 65ppm
	P ± 80ppm
T: 0°C to +70°C	S ± 100ppm
	D: ± 15ppm
	F: ± 25ppm
	K: ± 50ppm
	Z ± 65ppm
	P ± 80ppm
	S ± 100ppm

**Table: I**

Available Overall Tolerance Code		
Temp Range	Overall Tolerance	Temp Stability
B: -55°C to +105°C C: -55°C to +125°C F: -40°C to +105°C 7: -40°C to +125°C	Z: ± 65ppm	X
	P: ± 80ppm	X
	S: ± 100ppm	X
A: -55°C to +85°C E: -40°C to +85°C 8: -40°C to +95°C	K: ± 50ppm	X
	Z: ± 65ppm	X
	P: ± 80ppm	X
	S: ± 100ppm	X
T: 0°C to +70°C	F: ± 25ppm	X
	K: ± 50ppm	X
	Z: ± 65ppm	X
	P: ± 80ppm	X
	S: ± 100ppm	X

**Table: II**

This page is purposely left blank

**Notes:**

1. Contact factory for improved stabilities or additional product options. **Not all options and codes are available at all frequencies or operating temperature ranges: reference table on page 1.**
2. Unless other stated all values are valid after warm-up time and refer to typical conditions for supply voltage, frequency control voltage, load, temperature (25°C).
3. Subject to technical modification.
4. Contact factory for availability.
5. **Enable Codes: Option A is standard for AC MOS, TTL and LVDS; Option C is standard for LVPECL. Contact factory for**

## For Additional Information, Please Contact

### USA:

Vectron International  
267 Lowell Road, Unit 102  
Hudson, NH 03051  
Tel: 1.888.328.7661  
Fax: 1.888.329.8328

### Europe:

Vectron International  
Landstrasse, D-74924  
Neckarbischofsheim, Germany  
Tel: +49 (0) 3328.4784.17  
Fax: +49 (0) 3328.4784.30

### Asia:

Vectron International  
68 Yin Cheng Road(C), 22nd Floor  
One LuJiaZui  
Pudong, Shanghai 200120, China  
Tel: 86.21.6194.6886  
Fax: 86.21.6194.6699

### Disclaimer

Vectron International reserves the right to make changes to the product(s) and or information contained herein without notice. No liability is assumed as a result of their use or application. No rights under any patent accompany the sale of any such product(s) or information.





Компания «ЭлектроПласт» предлагает заключение долгосрочных отношений при поставках импортных электронных компонентов на взаимовыгодных условиях!

Наши преимущества:

- Оперативные поставки широкого спектра электронных компонентов отечественного и импортного производства напрямую от производителей и с крупнейших мировых складов;
- Поставка более 17-ти миллионов наименований электронных компонентов;
- Поставка сложных, дефицитных, либо снятых с производства позиций;
- Оперативные сроки поставки под заказ (от 5 рабочих дней);
- Экспресс доставка в любую точку России;
- Техническая поддержка проекта, помощь в подборе аналогов, поставка прототипов;
- Система менеджмента качества сертифицирована по Международному стандарту ISO 9001;
- Лицензия ФСБ на осуществление работ с использованием сведений, составляющих государственную тайну;
- Поставка специализированных компонентов (Xilinx, Altera, Analog Devices, Intersil, Interpoint, Microsemi, Aeroflex, Peregrine, Syfer, Eurofarad, Texas Instrument, Miteq, Cobham, E2V, MA-COM, Hittite, Mini-Circuits, General Dynamics и др.);

Помимо этого, одним из направлений компании «ЭлектроПласт» является направление «Источники питания». Мы предлагаем Вам помощь Конструкторского отдела:

- Подбор оптимального решения, техническое обоснование при выборе компонента;
- Подбор аналогов;
- Консультации по применению компонента;
- Поставка образцов и прототипов;
- Техническая поддержка проекта;
- Защита от снятия компонента с производства.



#### Как с нами связаться

**Телефон:** 8 (812) 309 58 32 (многоканальный)

**Факс:** 8 (812) 320-02-42

**Электронная почта:** [org@eplast1.ru](mailto:org@eplast1.ru)

**Адрес:** 198099, г. Санкт-Петербург, ул. Калинина, дом 2, корпус 4, литера А.