



Product Specification	Model:	AWT-480272T43N09	Rev. No.	Issued Date.	Page.
			B	2011/11/30	1 / 20

Thin Film Transistor LCD MODULE
MODEL: AWT-480272T43N09
Customer's No.:

Acceptance

Approved and Checked by

Approved by	Checked by		Made by
			

Product Specification	Model:	AWT-480272T43N09	Rev. No.	Issued Date.	Page.
			B	2011/11/30	2 / 20

Record of Revisions

Rev	Date	Sub-Model	Description of change
A	Oct. 26, 2011		Preliminary Product Specification was first issued.
B	Nov. 30, 2011		Change Bezel outline and opening size

Product Specification	Model:	AWT-480272T43N09	Rev. No.	Issued Date.	Page.
			B	2011/11/30	3 / 20

Table of contents

- 1. General description**
- 2. Absolute maximum ratings**
- 3. Optical characteristics**
- 4. Block diagram**
- 5 Interface pin connection**
- 6. Electrical characteristics**
- 7. Reliability test items**
- 8. Outline dimension**
- 9. General precaution**

Product Specification	Model:	AWT-480272T43N09	Rev. No.	Issued Date.	Page.
			B	2011/11/30	4 / 20

1. General description

1.1 Introduction

The model AWT-480272T43N09 is a color active matrix thin film transistor (TFT) liquid crystal display (LCD) that uses amorphous silicon TFT as a switching device. This model is composed of a TFT LCD panel, a driving circuit and a back light system. This TFT LCD has a 4.3 (16:9) inch diagonally measured active display area with WQVGA (480 horizontal by 272 vertical pixel) resolution.

1.2 Features

- 4.3 (16:9 diagonal) inch configuration
- 6 bits + FRC driver with 1channel TTL interface
- LED Backlight
- Up/Down, Left/Right reversion selection
- RoHS Compliance

1.3 Applications

- Mobile NB
- Digital Photo frame
- Multimedia applications and Others AV system

1.4 General information

Item	Specification	Unit	
Outline Dimension	105.52 x 67.22 x 2.8 (Typ.)	mm	
Display area	95.04(H) x 53.85(V)	mm	
Number of Pixel	480 RGB(H) x 272(V)	pixels	
Pixel pitch	0.198(H) x 0.198(V)	mm	
Pixel arrangement	RGB Vertical stripe		
Display mode	Normally white		
Surface treatment	Antiglare, Hard-Coating(3H) with EWV Pol.		
Weight	45	g	
Back-light	Single LED (Side-Light type)		
Power Consumption	B/L System	0.8	w
	Panel Assembly	0.05	w

1.5 Mechanical Information

item	Min.	Typ.	Max.	Unit	
Module Size	Horizontal(H)	105.32	105.52	105.72	mm
	Vertical(V)	67.02	67.22	67.42	mm
	Depth(D)	2.5	2.8	3.1	mm

Product Specification	Model:	AWT-480272T43N09	Rev. No.	Issued Date.	Page.
			B	2011/11/30	5 / 20

2.0 ABSOLUTE MAXIMUM RATINGS

2.1 Electrical Absolute Rating

2.1.1 TFT LCD Module

Item	Symbol	Min.	Max.	Unit.	Note
Power supply voltage	VDD	-0.3	6.0	V	GND=0
	VGH	0.3	40	V	GND=0
	VGL	-20	0.3	V	GND=0
	AVDD	0.5	15	V	AGND=0
	VCOM	0	6	V	
Logic Signal Input Level	V1	-0.3	VDD+0.3	V	

2.1.2 Back-Light Unit

Item	Symbol	MIN.	TYP.	MAX.	Unit	Note
Forward voltage	Vf	17.8	18.2	18.6	V (1)(2)	
Forward current	If	30	40	50	mA	(1)(2) (3)
Power Consumption	PBL	--	0.8	--	W	

Note:

(1) Permanent damage may occur to the LCD module if beyond this specification. Functional operation should be restricted to the conditions described under normal operating conditions.

(2) Ta = 25 ± 2°C

(3) Test Condition: LED current 40 mA

2.2 Environment Absolute Rating

Item	Symbol	Min.	Max.	Unit	Remarks
Operating Temperature	Topa	-20	+70	°C	
Storage Temperature	Tstg	-30	+80	°C	

Product Specification	Model:	AWT-480272T43N09	Rev. No.	Issued Date.	Page.
			B	2011/11/30	6 / 20

3.0 OPTICAL CHARACTERISTICS

3.1 Optical specification:

Item	Symbol	Temp.	Min.	Typ.	Max.	Unit	Condition
Response Time	Tr	25°C	5	7	--	msec	$\theta = 0^\circ, \phi = 0^\circ$ (Note 1,3)
	Tf	25°C	20	28	--		
Contrast Rate	Cr	25°C	400	500	--	--	$\theta = 0^\circ, \phi = 0^\circ$ LED:ON, LIGHT:OFF(Note1,2)
Brightness	YL	25°C	400	500	--	Cd/m ²	(IL=20mA)(Note1,4)
Visual angle range front and rear	θ	25°C	(θU) 40 (θD) 70			De-gree	$\phi = 0^\circ, CR \geq 10$ LED:ON LIGHT:OFF(Note 1,4)
Visual angle range left and right	θ	25°C	(θL) 50 (θR) 50			De-gree	$\phi = 90^\circ, CR \geq 10$ LED:ON LIGHT:OFF(Note 1,4)
Brightness uniformity	BUNI		70			%	$\Theta = 0$ (Note5,7)
Visual angle			6:00				(Note 6)

3.2 Measuring Condition

Measuring surrounding: dark room ,LED current IL : 40mA

Ambient temperature: 25±2oC

15min. warm-up time.

3.3 Measuring Equipment

FPM520 of Westar Display technologies, INC., which utilized SR-3 for Chromaticity and BM-7 for other optical characteristics. Measuring spot size: 20 ~ 21 mm

Product Specification	Model:	AWT-480272T43N09	Rev. No.	Issued Date.	Page.
			B	2011/11/30	7/20

Note (1) Definition of Viewing Angle :

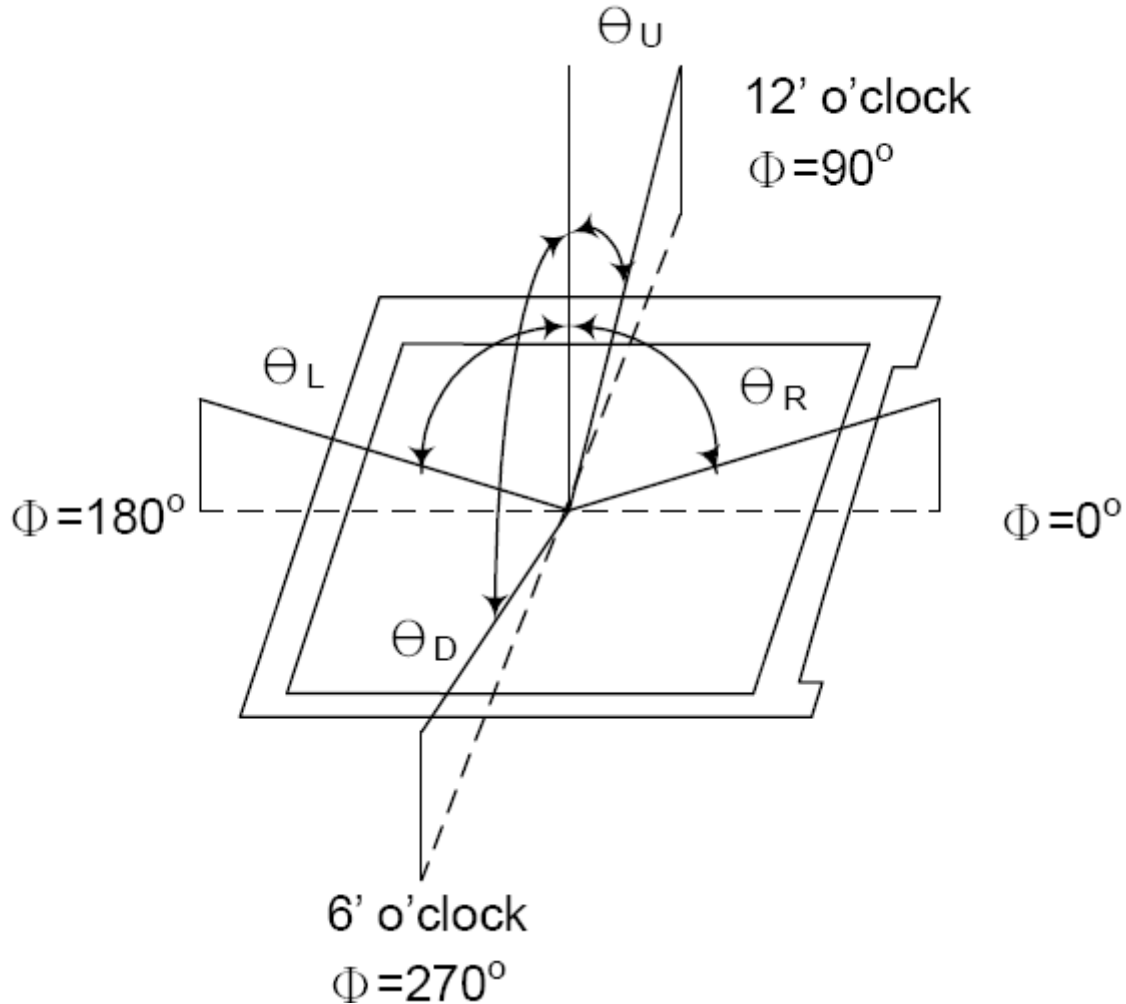

Note (2) Definition of Contrast Ratio (CR):
Measured at the center point of panel

$$CR = \frac{\text{Luminance with all pixels white}}{\text{Luminance with all pixels black}}$$

Product Specification	Model:	AWT-480272T43N09	Rev. No.	Issued Date.	Page.
			B	2011/11/30	8/20

Note (3) Definition of Response Time: Sum of TR and TF

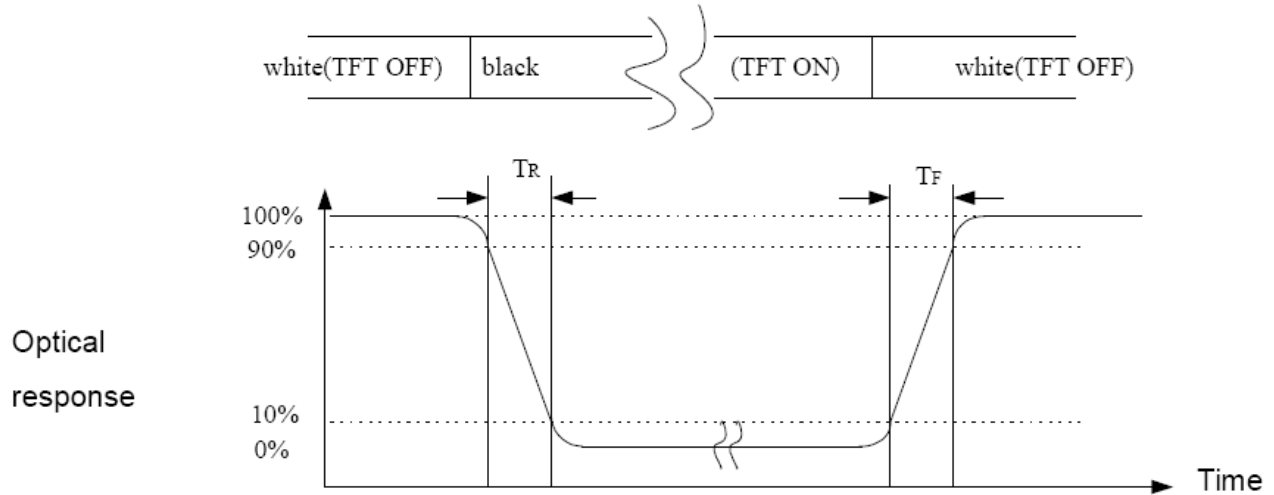

Note (4) Definition of optical measurement setup

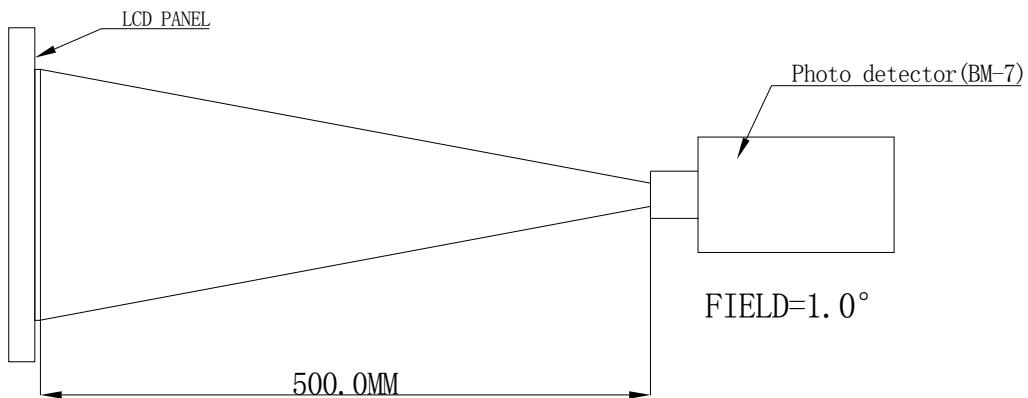

Product Specification	Model:	AWT-480272T43N09	Rev. No.	Issued Date.	Page.
			B	2011/11/30	9 / 20

Note (5) Definition of brightness uniformity

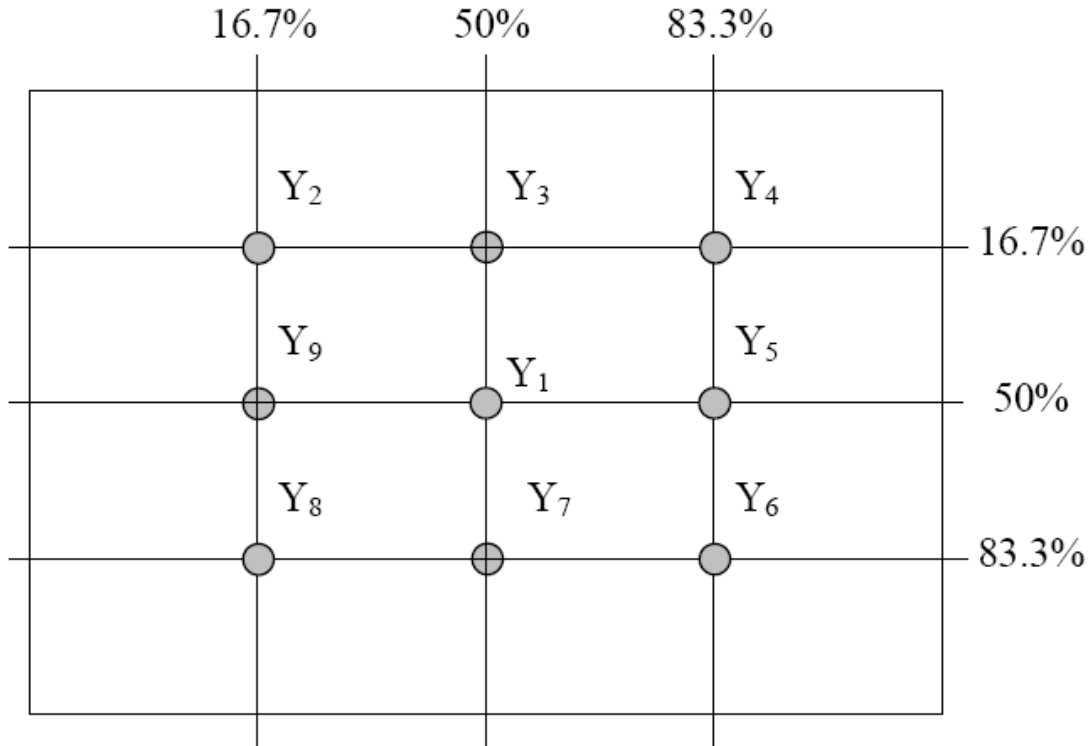

$$\text{Luminance uniformity} = \frac{(\text{Min Luminance of 9 points})}{(\text{Max Luminance of 9 points})} \times 100\%$$

Note (6) Rubbing Direction (The different Rubbing Direction will cause the different optimal view direction).

Note (7) Measured at the brightness of the panel when all terminals of LCD panel are electrically open.

Product Specification	Model:	AWT-480272T43N09	Rev. No.	Issued Date.	Page.
			B	2011/11/30	10 / 20

4.0 BLOCK DIAGRAM

4.1 TFT LCD Module

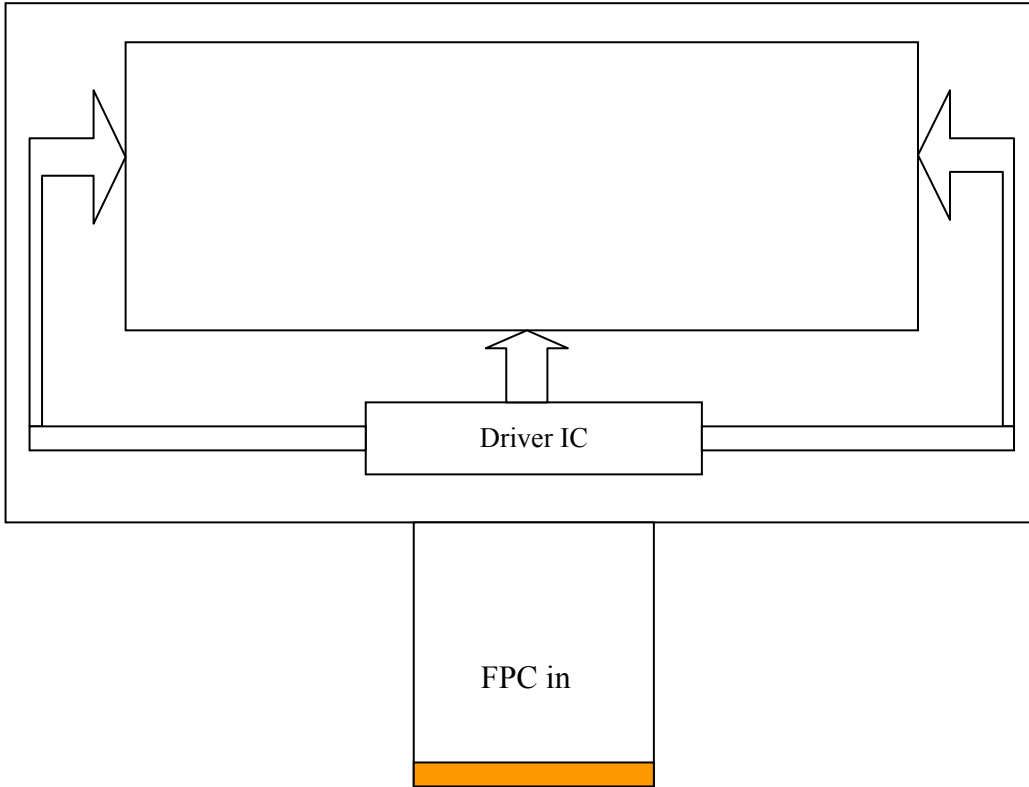

4.2 Pixel Format

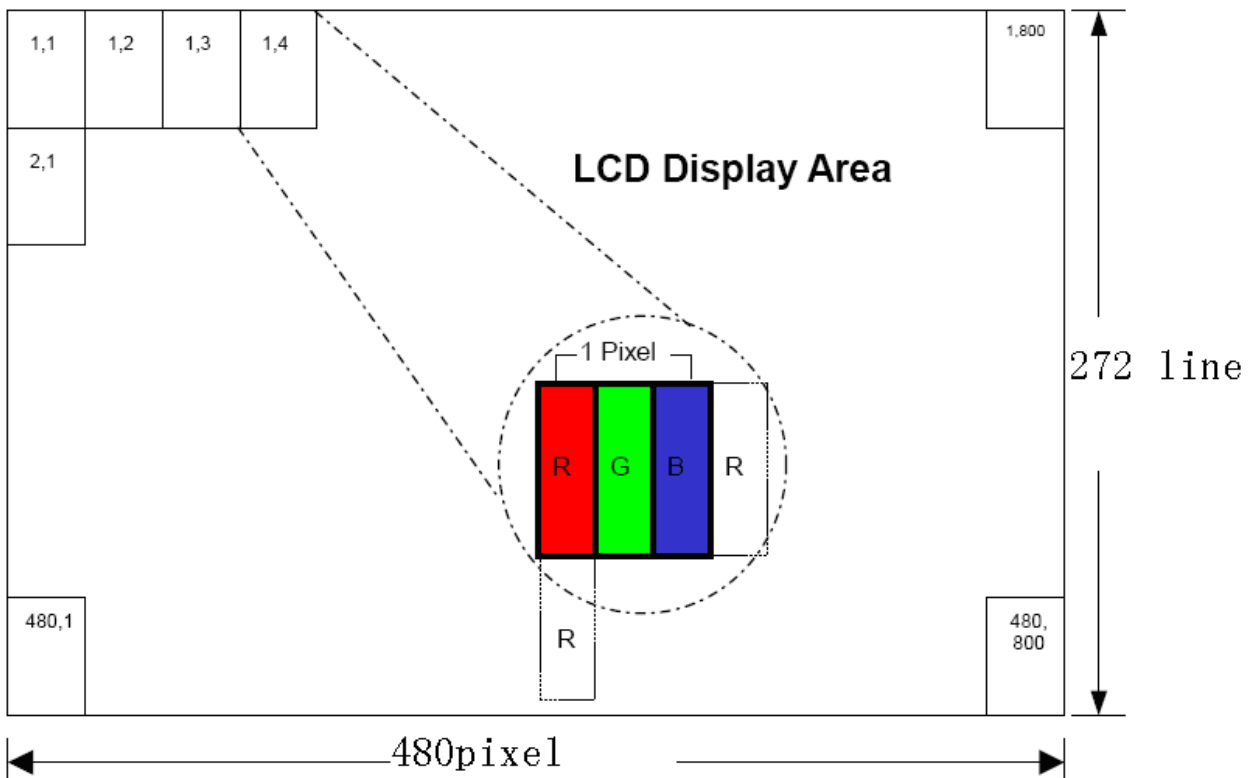

Product Specification	Model:	AWT-480272T43N09	Rev. No.	Issued Date.	Page.
			B	2011/11/30	11 / 20

5.0 INTERFACE PIN CONNECTION

5.1 TFT LCD ModuleCN2 (Input signal): FPC Down Connector, (FH28-40S-0.5SH (HIROSE), 40pin, pitch = 0.5mm)

Terminal No.	Symbol	IO	Functions
1	LEDK	P	Power for LED backlight cathode
2	LEDA	P	Power for LED backlight anode
3	GND	P	Power Ground
4	VDD	P	Power Voltage
5	R0	I	Data Input(LSB)
6	R1	I	Data Input
7	R2	I	Data Input
8	R3	I	Data Input
9	R4	I	Data Input
10	R5	I	Data Input
11	R6	I	Data Input
12	R7	I	Data Input (MSB)
13	G0	I	Data Input (LSB)
14	G1	I	Data Input
15	G2	I	Data Input
16	G3	I	Data Input
17	G4	I	Data Input
18	G5	I	Data Input
19	G6	I	Data Input
20	G7	I	Data Input(MSB)
21	B0	I	Data Input(LSB)
22	B1	I	Data Input
23	B2	I	Data Input
24	B3	I	Data Input
25	B4	I	Data Input
26	B5	I	Data Input
27	B6	I	Data Input
28	B7	I	Data Input(MSB)
29	GND	P	Power Ground
30	DCLK	I	Dot data clock
31	DISP	I	Display on/ off

Product Specification	Model:	AWT-480272T43N09	Rev. No.	Issued Date.	Page.
			B	2011/11/30	12 / 20

32	HSYNC	I	Horizontal sync Signal
33	VSNC	I	Vertical sync signal
34	DE	I	Data Enable
35	NC	--	No Connect
36	GND	P	Power Ground
37	NC	I/O	No Connect
38	NC	I/O	No Connect
39	NC	I/O	No Connect
40	NC	I/O	No Connect

5.2 Back-Light Unit

CN1 LED Power Source (BHSR-02VS-1) or equivalent

Mating Connector: (SBHT-002T-P0.5) or equivalent

Terminal no.	Symbol	Function
1	VL	LED power supply (high voltage)
2	GL	LED power supply (low voltage)

Product Specification	Model:	AWT-480272T43N09	Rev. No.	Issued Date.	Page.
			B	2011/11/30	13 / 20

6.0 ELECTRICAL CHARACTERISTICS

6.1 TFT LCD Module

Item	Symbol	Min.	Typ.	Max.	Unit	Note
Power in	VDD	2.7	3.3	3.6	V	2
Digital in	Din	0	-	VDD	V	1

Note (1): HSYNC, VSYNC, DE, Digital Data

Note (2): Be sure to apply the power voltage as the power sequence spec.

Note (3): DGND=AGND=0V

6.2 Back-Light Unit

The backlight system is an edge-lighting type with 12 LED.

The characteristics of the LED are shown in the following tables.

Item	Symbol	Min.	Typ.	Max.	Unit	Note
LED current	IL	30	40	50	mA	(2)
LED Voltage	VL	17.8	18.2	18.6	V	
Operating LED life time	Hr	20000	-	-	Hour	(1)(2)

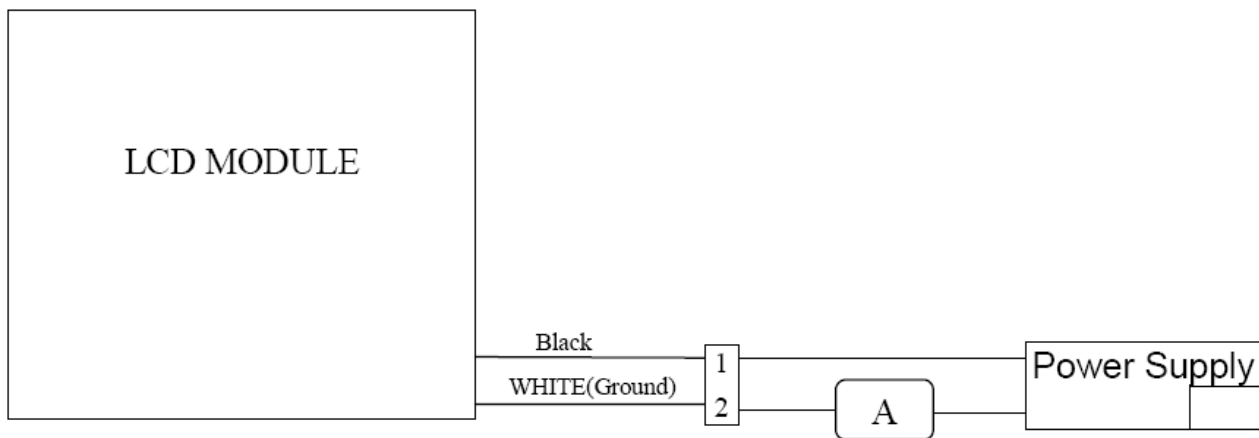

Note (1) LED life time (Hr) can be defined as the time in which it continues to operate under the condition: $T_a=25\pm3$ oC, typical $I_L=40$ mA value indicated in the above table until the brightness becomes less than 50%.

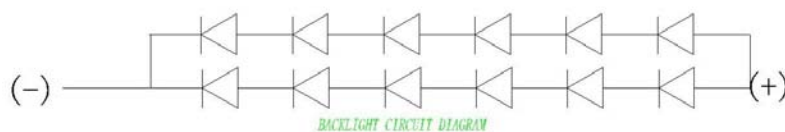

Product Specification	Model:	AWT-480272T43N09	Rev. No.	Issued Date.	Page.
			B	2011/11/30	14 / 20

6.3 AC Characteristics

Item	Symbol	Min.	Typ.	Max.	Unit	Note
DCLK clock time	Tclk	83	110	200	ns	DCLK=9MHz
DCLK clock low period	Tcwl	40	-	60	%	
DCLK clock high period	Tcwh	40	-	60	%	
Clock rising time	Trck	9	-	-	ns	
Clock falling time	Tfck	9	-	-	ns	
HSD width	Thwh	1	-	-	DCLK	
HSD period time	Th	55	60	65	us	
HSD setup time	Thsu	12	-	-	ns	
HSD hold time	Thhd	12	-	-	ns	
VSD width	Thwh	1	-	-	Th	
VSD setup time	Tvsu	12	-	-	ns	
VSD hold time	Tvhd	12	-	-	ns	
Data setup time	Tdasu	12	-	-	ns	
Data hold time	Tdahd	12	-	-	ns	
DEN setup time	Tdesu	12	-	-	ns	
DEN hold time	Tdehd	12	-	-	ns	

6.4 Timing Diagram of Interface Signal

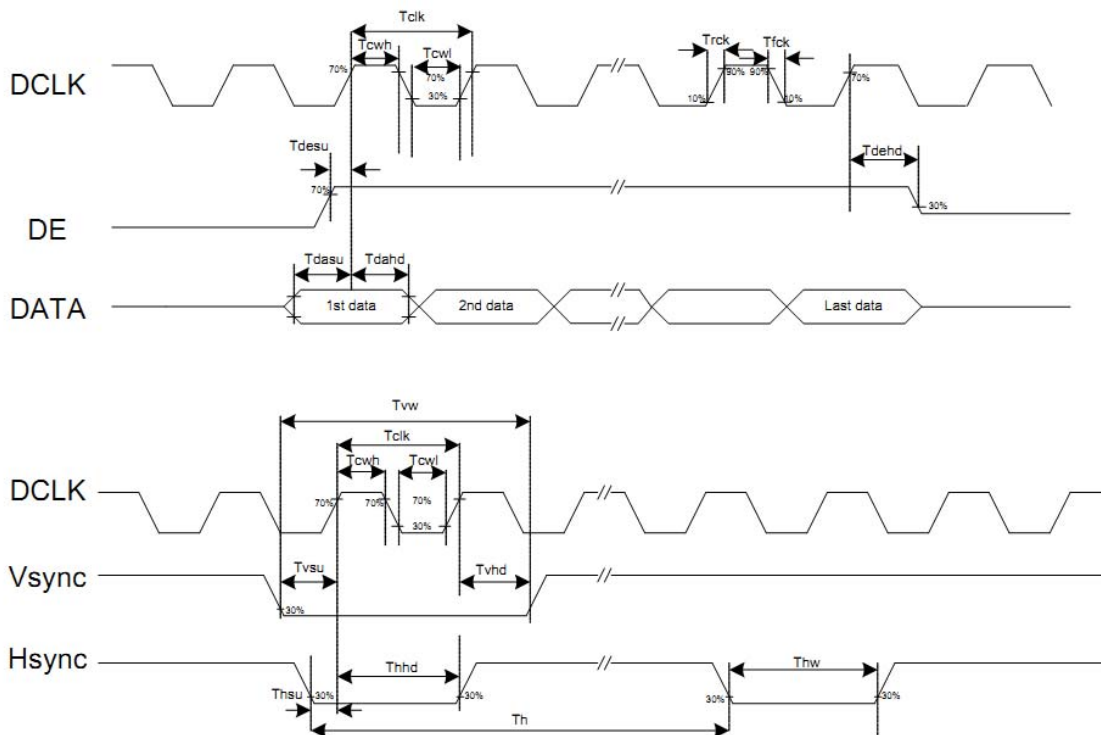

Product Specification	Model:	AWT-480272T43N09	Rev. No.	Issued Date.	Page.
			B	2011/11/30	15 / 20

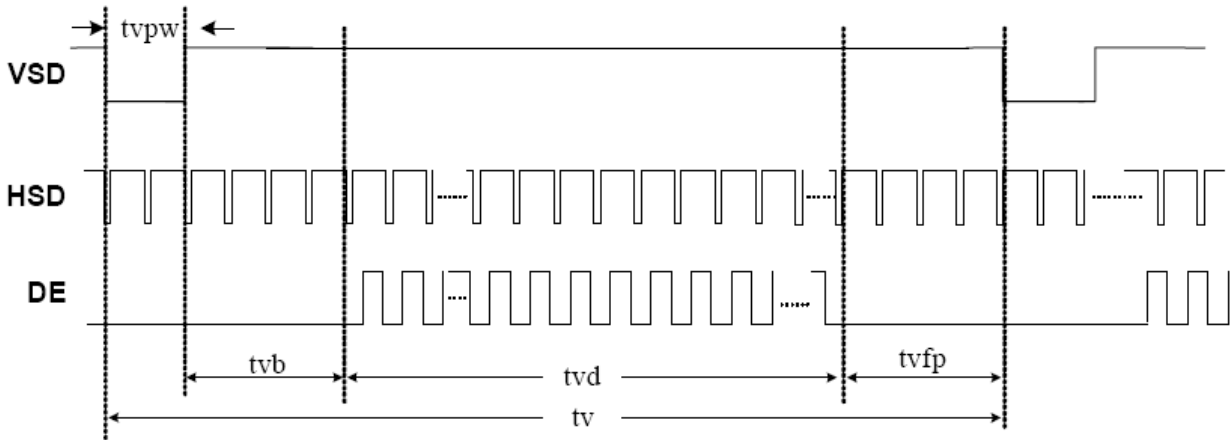

Vertical timing

Item	Symbol	Min.	Typ.	Max.	Unit	Note
DCLK frequency	Fclk	5	9	12	MHz	
VSD period time	Tv	277	288	400	Th	
VSD display area	Tvd	272			Th	
VSD back porch	Tvb	3	8	31	Th	
VSD front porch	Tvfp	2	8	93	Th	
HSD period time	Th	520	525	800	DCLK	
HSD display area	Thd	480			DCLK	
HSD back porch	Thb	36	40	255	DCLK	
HSD front porch	Thfp	4	5	65	DCLK	

6.5 Power Sequence

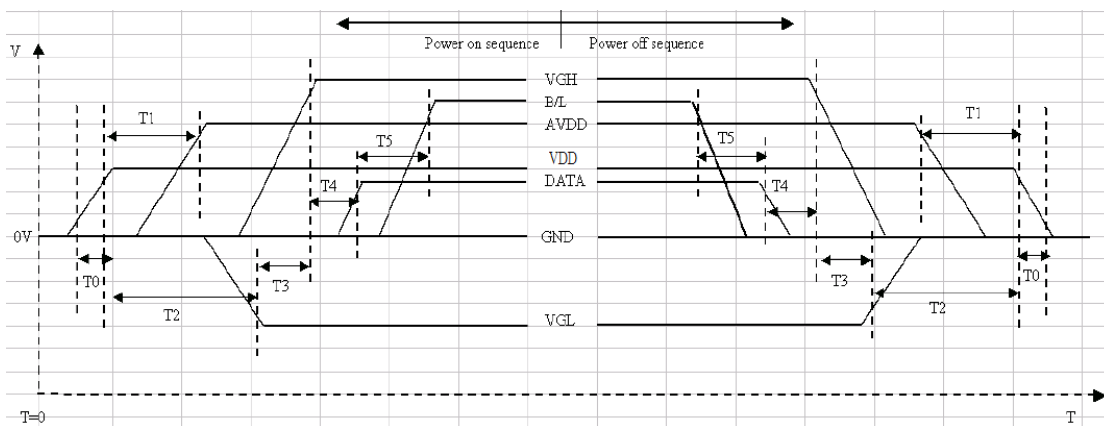

Product Specification	Model:	AWT-480272T43N09	Rev. No.	Issued Date.	Page.
			B	2011/11/30	16 / 20

Item	Min.	Typ.	Max.	Unit
T0	0.5	--	20	msec
T1	16			msec
T2	20			msec
T3	10			msec
T4	10		50	msec
T5	50			msec

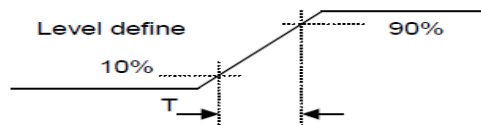

Power On Sequence : VDD=>DATA=>B/L

Power Off Sequence: B/L=>DATA=> VDD

NOTES:

Data Include R0~R7,G0~G7,B0~B7,HSD,HSD,VSD,DCLK, DE,DISP

Product Specification	Model:	AWT-480272T43N09	Rev. No.	Issued Date.	Page.
			B	2011/11/30	17 / 20

7.0 Reliability test items

Test Item	Test Conditions	Notes
High temperature Operation	70±3°C , T=240hrs	
Low temperature Operation	-20±3°C , T=240hrs	
High Temperature Storage	80±3°C , T=240hrs	1,2
Low Temperature Storage	-30±3°C , T=240hrs	1,2
Humidity Test	60°C , Humidity 90% , 240hrs	1,2
Thermal Shock Test	-30°C, 30min~80°C, 30min (200 cycle)	1,2
Vibration Test(Packing)	Sweep frequency 10~55~10HZ/min Amplitude:0.75mm Test direction:X, Y, Z/3 axis Duration 30min/each axis	2
Static Electricity	150Pf 330ohm ±8KV, 10time air discharge ±4KV, 10time connect discharge	

Product Specification	Model:	AWT-480272T43N09	Rev. No.	Issued Date.	Page.
			B	2011/11/30	18 / 20

8.0 OUTLINE DIMENSION

Outline Dimension:

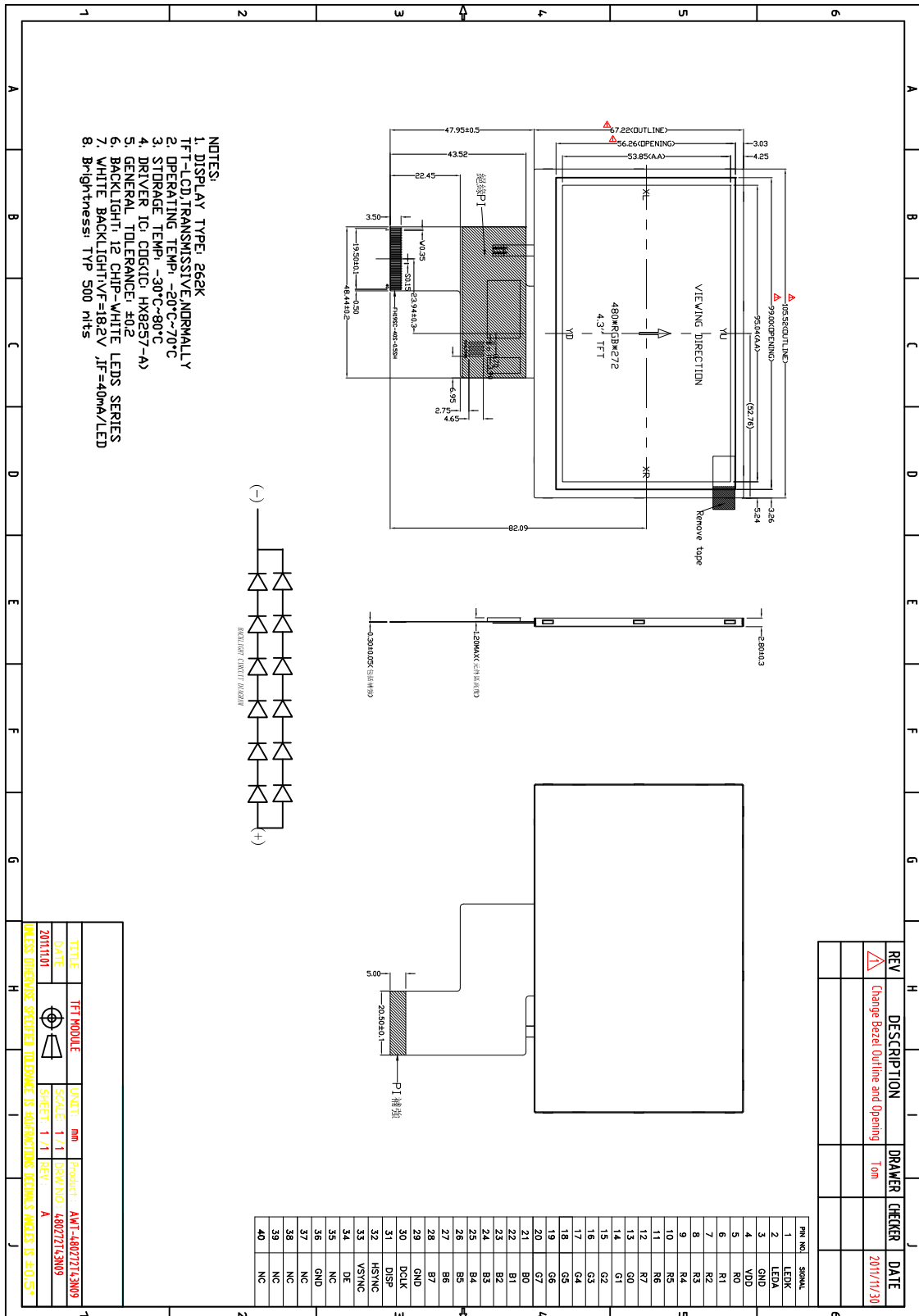

Product Specification	Model:	AWT-480272T43N09	Rev. No.	Issued Date.	Page.
			B	2011/11/30	19 / 20

9.0 GENERAL PRECAUTION

9.1 Use Restriction

This product is not authorized for use in life supporting systems, aircraft navigation control systems, military systems and any other application where performance failure could be life threatening or otherwise catastrophic.

9.2 Disassembling or Modification

Do not disassemble or modify the module. It may damage sensitive parts inside LCD module, and may cause scratches or dust on the display. ACROWISE does not warrant the module, if customers disassemble or modify the module.

9.3 Breakage of LCD Panel

9.3.1. If LCD panel is broken and liquid crystal spills out, do not ingest or inhale liquid crystal, and do not contact liquid crystal with skin.

9.3.2. If liquid crystal contacts mouth or eyes, rinse out with water immediately.

9.3.3. If liquid crystal contacts skin or cloths, wash it off immediately with alcohol and rinse thoroughly with water.

9.3.4. Handle carefully with chips of glass that may cause injury, when the glass is broken.

9.4 Electric Shock

9.4.1. Disconnect power supply before handling LCD module.

9.4.2. Do not pull or fold the LED cable.

9.4.3. Do not touch the parts inside LCD modules and the fluorescent LED's connector or cables in order to prevent electric shock.

9.5 Absolute Maximum Ratings and Power Protection Circuit

9.5.1. Do not exceed the absolute maximum rating values, such as the supply voltage variation, input voltage variation, variation in parts' parameters, environmental temperature, etc., otherwise LCD module may be damaged. 9.5.2. Please do not leave LCD module in the environment of high humidity and high temperature for a long time. 11.5.3. It's recommended to employ protection circuit for power supply.

9.6 Operation

9.6.1 Do not touch, push or rub the polarizer with anything harder than HB pencil lead.

9.6.2 Use fingerstalls of soft gloves in order to keep clean display quality, when persons handle the LCD module for incoming inspection or assembly.

Product Specification	Model:	AWT-480272T43N09	Rev. No.	Issued Date.	Page.
			B	2011/11/30	20 / 20

9.6.3 When the surface is dusty, please wipe gently with absorbent cotton or other soft material.

9.6.4 Wipe off saliva or water drops as soon as possible. If saliva or water drops contact with polarizer for a long time, they may causes deformation or color fading.

9.6.5 When cleaning the adhesives, please use absorbent cotton wetted with a little petroleum benzine or other adequate solvent.

9.7 Mechanism

Please mount LCD module by using mouting holes arranged in four corners tightly.

9.8 Static Electricity

9.8.1 Protection film must remove very slowly from the surface of LCD module to prevent from electrostatic occurrence.

9.8.2. Because LCD module use CMOS-IC on circuit board and TFT-LCD panel, it is very weak to electrostatic discharge. Please be careful with electrostatic discharge. Persons who handle the module should be grounded through adequate methods.

9.9 Strong Light Exposure

The module shall not be exposed under strong light such as direct sunlight. Otherwise, display characteristics may be changed.

9.10 Disposal

When disposing LCD module, obey the local environmental regulations.



Компания «ЭлектроПласт» предлагает заключение долгосрочных отношений при поставках импортных электронных компонентов на взаимовыгодных условиях!

Наши преимущества:

- Оперативные поставки широкого спектра электронных компонентов отечественного и импортного производства напрямую от производителей и с крупнейших мировых складов;
- Поставка более 17-ти миллионов наименований электронных компонентов;
- Поставка сложных, дефицитных, либо снятых с производства позиций;
- Оперативные сроки поставки под заказ (от 5 рабочих дней);
- Экспресс доставка в любую точку России;
- Техническая поддержка проекта, помощь в подборе аналогов, поставка прототипов;
- Система менеджмента качества сертифицирована по Международному стандарту ISO 9001;
- Лицензия ФСБ на осуществление работ с использованием сведений, составляющих государственную тайну;
- Поставка специализированных компонентов (Xilinx, Altera, Analog Devices, Intersil, Interpoint, Microsemi, Aeroflex, Peregrine, Syfer, Eurofarad, Texas Instrument, Miteq, Cobham, E2V, MA-COM, Hittite, Mini-Circuits, General Dynamics и др.);

Помимо этого, одним из направлений компании «ЭлектроПласт» является направление «Источники питания». Мы предлагаем Вам помощь Конструкторского отдела:

- Подбор оптимального решения, техническое обоснование при выборе компонента;
- Подбор аналогов;
- Консультации по применению компонента;
- Поставка образцов и прототипов;
- Техническая поддержка проекта;
- Защита от снятия компонента с производства.



Как с нами связаться

Телефон: 8 (812) 309 58 32 (многоканальный)

Факс: 8 (812) 320-02-42

Электронная почта: org@eplast1.ru

Адрес: 198099, г. Санкт-Петербург, ул. Калинина, дом 2, корпус 4, литера А.