



Global Voice ISOModem-EVB

Evaluation Board for the Si2494/39/38/37/36/35/29/19/18/17 ISOModem

Description

The Global Voice ISOModem EVB evaluation board provides the system designer with an easy way of evaluating the ISOModem[®]. The Voice ISOModem EVB consists of a motherboard with a complete removable daughter card

The Voice ISOModem is a complete controller based modem chipset with an integrated and programmable direct access arrangement (DAA) that meets the global telephone line requirements. It is available in a 24-pin or 38-pin system side device and a 16-pin line side device. The hardware versions at the time of publication are:

- Voice Mother Board Si24xxVMB Rev 2.0
- Modem Daughter Card Si24xx2G-DC Rev 2.0
- Modem Daughter Card Si24xx2G-QFN38-DC Rev 1.0

The voice daughter card is populated with the correct ISOModem system side chip (Si2494/39/38/37/36/35/29/19/18/17) and the correct line side DAA chip, the Si3018 to suit the voice applications.

The ISOModem eliminates the need for a separate DSP data pump, modem controller, memories, codec, isolation transformers, relays, opto-isolators and a 3-4 wire hybrid. The ISOModem is ideal for embedded modem and voice applications due to its small board area, controller based architecture, low power consumption and global compliance.

An onboard rectifier, filter, and voltage regulator allow the power input to be 7.5–13 V ac or dc (either polarity) supplied through a screw terminal (J8) or a standard 2 mm power jack (J9). Alternatively, power can be supplied through the USB interface (whether the USB or RS232 interface is used).

The Power Source Selection is automatic, while the signaling port is selected by a jumper (JP23).

The evaluation board audio power amplifier can drive an external speaker for either call progress monitoring or speakerphone function. A small onboard speaker, suitable for call progress monitoring, is installed.

Please note that fax modem versions listed in the title require a software driver in order to implement fax send/receive functionality. The driver must be compliant with the Silicon Labs ISOModem and with applicable ITU-T standards (e.g., T.30, T.31, T.4 and T.6) Contact Silicon Labs for details.

Features

This evaluation board includes the following:

- Socketed module with the modem chipset
- USB or asynch RS232 Serial Interface
- RJ11 connection to the phone line
- Onboard relay-excludable RJ11 connection
- RS232 and USB interface to the PC
- Direct access to the ISOModem signals for embedded system evaluation
- Power from a provided 8.5–13.5 V dc power supply or from the USB port
- Handset connector (J1)
- Onboard hookswitch
- External hookswitch connector
- Jumper matrix that allows any handset wiring scheme to work with this board
- Onboard speakerphone microphone
- RCA jack connector to an optional off-board speakerphone electret microphone
- Selectable and adjustable electret power supplies for both handset and speakerphone microphones
- Onboard 300 mW audio power amplifier (into a 4 Ω load) for driving either onboard or external speaker.
- Onboard voice coil driven loudspeaker for call monitoring
- LED display of all RS232 signals

Si2494/39/38/37/36/35/29/19/18/17FT18-EVB

Functional Block Diagram

As shown in Figure 1, the daughter card is a plug-in component with the complete modem, while the rest of the motherboard provides selectable serial RS232 or USB links, the sound subsystem, and power regulation and distribution.

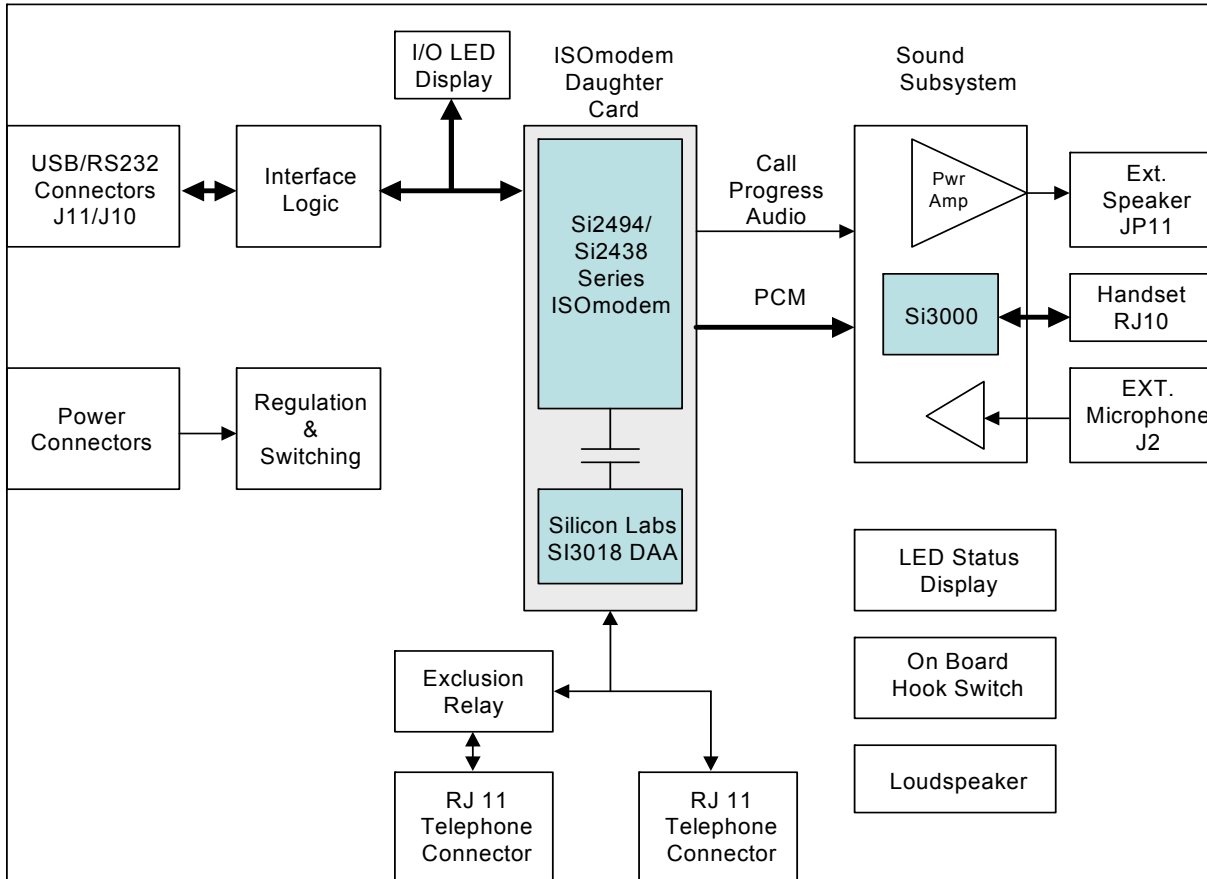

Figure 1. Functional Block Diagram

The voice ISOmodem EVB provides a sound system consisting of the Si3000 codec along with a handset RJ10 connector as well as onboard microphone and loudspeaker with options for these devices to be placed off-board.

The bias voltages for both the onboard microphone and the handset microphone can be modified and alternate sources used.

This allows the board to be used as a telephone or as a speakerphone as is, or to be integrated into the customer's system.

The evaluation board can drive an external speaker or a small onboard speaker. For speaker-phone applications it is recommended that an off board loudspeaker be used.

An onboard rectifier, filter and voltage regulator allow the power input to be 8.5 to 13.5 V peak ac or dc of either polarity supplied through screw terminals (J8) or a standard 2 mm power jack (J9). Alternatively the power can be supplied through the USB interface. Automatic switching is provided for the power, but not for the data interface. That data interface is selected by JP23.

1. Global Voice ISModem EVB

The evaluation board is shown in Figure 2. Note the socketed daughter card with the modem chipset on the bottom right of the board.

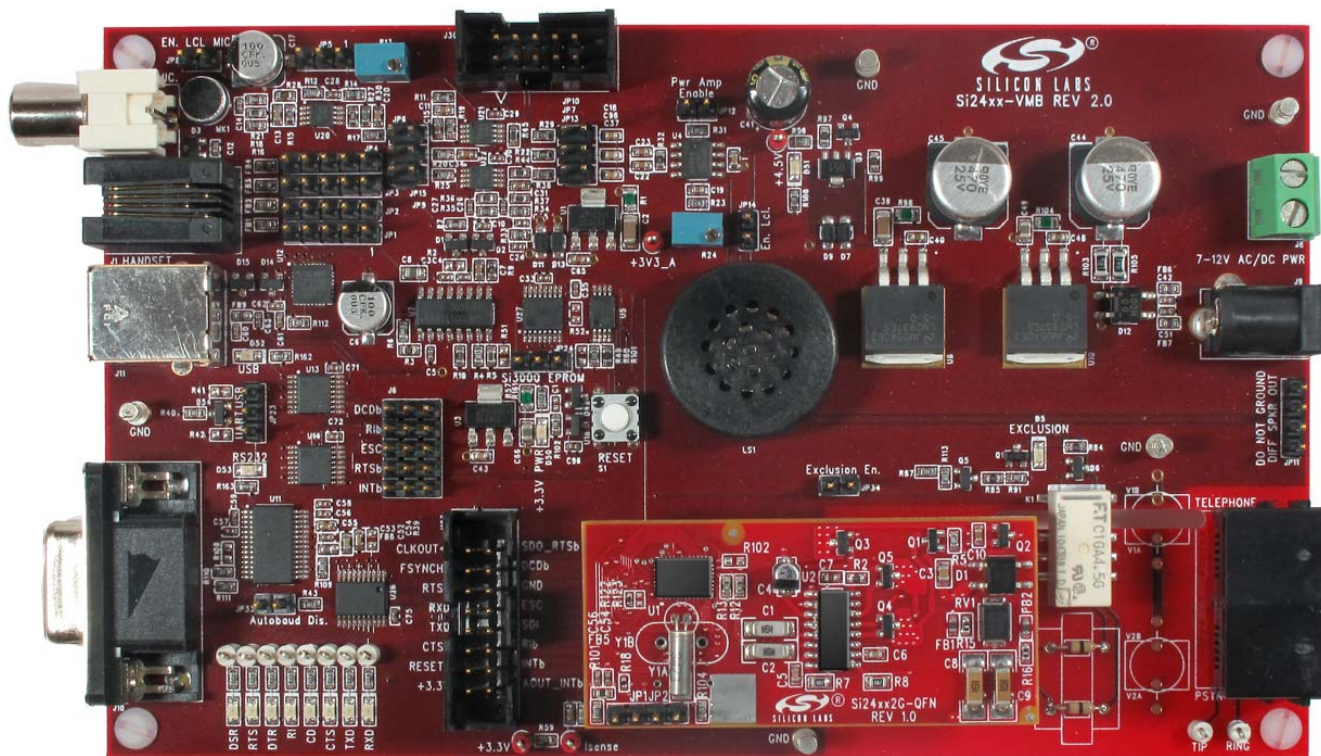

Figure 2. Global Voice ISModem Evaluation Board

The ISModem chip requires software driver in order to perform either FAX or sound functionality. Contact Silicon Labs for details. “AN244: Si2438/37/36/35/29/19/18/17 Fax Modem Designer’s Guide” and “AN93: Si2494/93/57/39/34/15/04 Data Modem Designer’s Guide” are useful for driver development.

The Global Voice ISModem EVB provides an RJ11 jack for interfacing to the phone line and the USB or serial ports can interface to a PC or a host CPU. This allows the board to operate as a class 1 fax modem for an evaluation or as a global voice and data modem (depending on the specific ISModem used).

A handset, microphone and speaker can also be attached to demonstrate the sound features, which may include TAM and speaker-phone operations, depending on the specific ISModem chip used. Table 1 lists which ISModem chips have these features. A software driver or application is required to perform these data and sound operations. The included UltraCOM application can demonstrate the sound features of the ISModem and provides a tool to aid development.

Si2494/39/38/37/36/35/29/19/18/17FT18-EVB

2. Daughter Cards

There are two types of daughter cards available for this EVB. One supports the TSSOP version of the system side chip, and the other supports the QFN38 version of the system side.

An example of the TSSOP version of the daughter card is shown in Figure 3. It has the ISOModem system-side chip as well as the Si3018 DAA chip. The left side of the board contains the system side while the right side contains the DAA chip along with the few interface parts needed to connect to a telephone line.

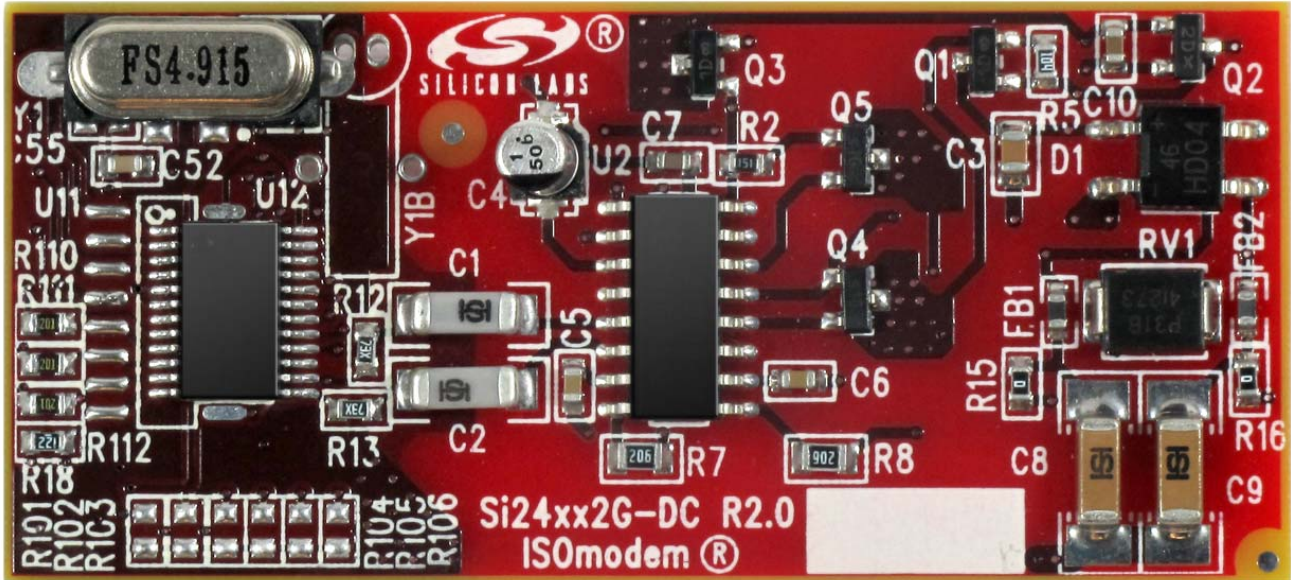

Figure 3. Daughter Card

Although this card is provided as part of the global voice EVB, it can also be directly connected to an embedded system using TTL logic.

When run by a software driver the chipset on this daughter card is capable of making fax calls, telephone calls with a handset, data calls and both. TAM and speaker-phone operations. Table 1 lists the various ISOModem chips and their features.

Table 1. ISOModem Features

Part Number	Fax	Data	Handset	TAM	Speaker Phone
Si2417	≤V.17	—	✓	—	—
Si2418	≤V.17	—	✓	✓	✓
Si2419	≤V.17	≤V.32bis	✓	—	—
Si2429	≤V.29	—	✓	✓	✓
Si2435	≤V.34	—	✓	—	—
Si2436	≤V.34	—	✓	✓	✓
Si2437	≤V.34	≤V.34	✓	—	—
Si2438	≤V.34	≤V.34	✓	✓	✓
Si2439	—	≤V.34	✓	✓	✓
Si2494	—	≤V.92	✓	✓	✓

3. Setup and Evaluation

This section explains how to set up the Voice ISOmodem EVB for evaluation as an RS-232 or USB interface. Jumper settings and system interconnections are given, as well as the use of a demonstration and test application provided called UltraCOM.

See the following documents for additional technical details

- Si2494/39/38/37/36/35/29/19/18/17 data sheets
- “AN244: Fax Modem Designer’s Guide”
- “AN93: Data Modem Designer’s Guide”

Diagrams and tables are provided here that define the operation of all the jumpers, settings and connectors, as well as their default states.

A typical global voice EVB as it arrives from the factory can be connected into a system by using only four cables.

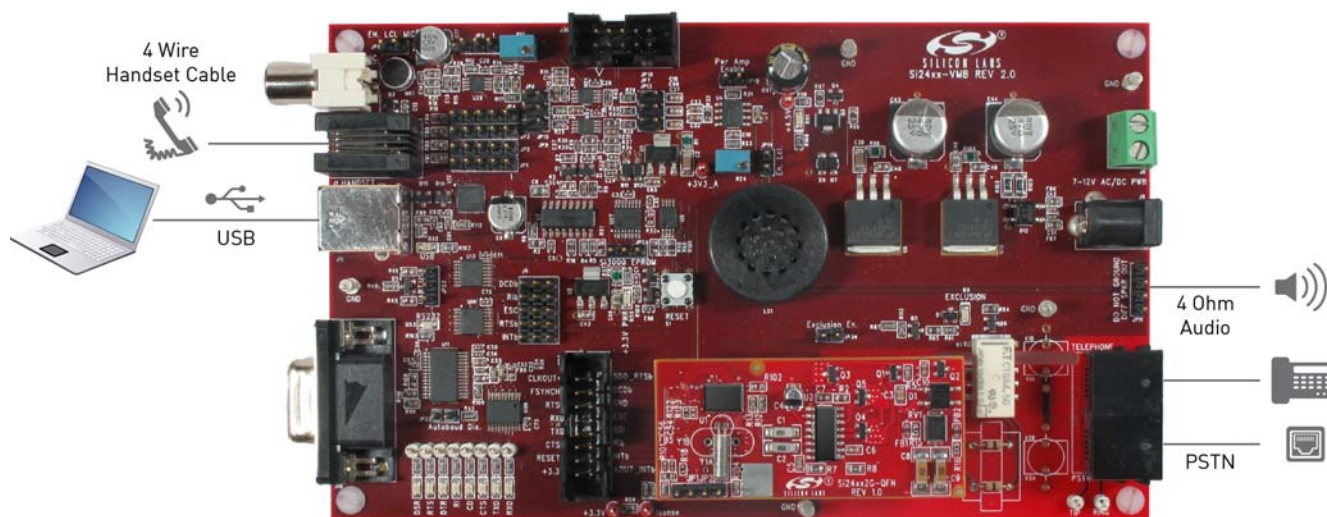

Figure 4. Global Voice ISOmodem EVB Connection

The UltraCOM application provided on the included CD can be used to demonstrate:

- Telephone Operation.
- Speakerphone Operation
- Telephone answering machine operation.

Fax Operation can be demonstrated but requires a fax driver application.

Si2494/39/38/37/36/35/29/19/18/17FT18-EVB

3.1. Jumpers

Figure 5 shows the function and location of the jumpers present on the global fax EVB.

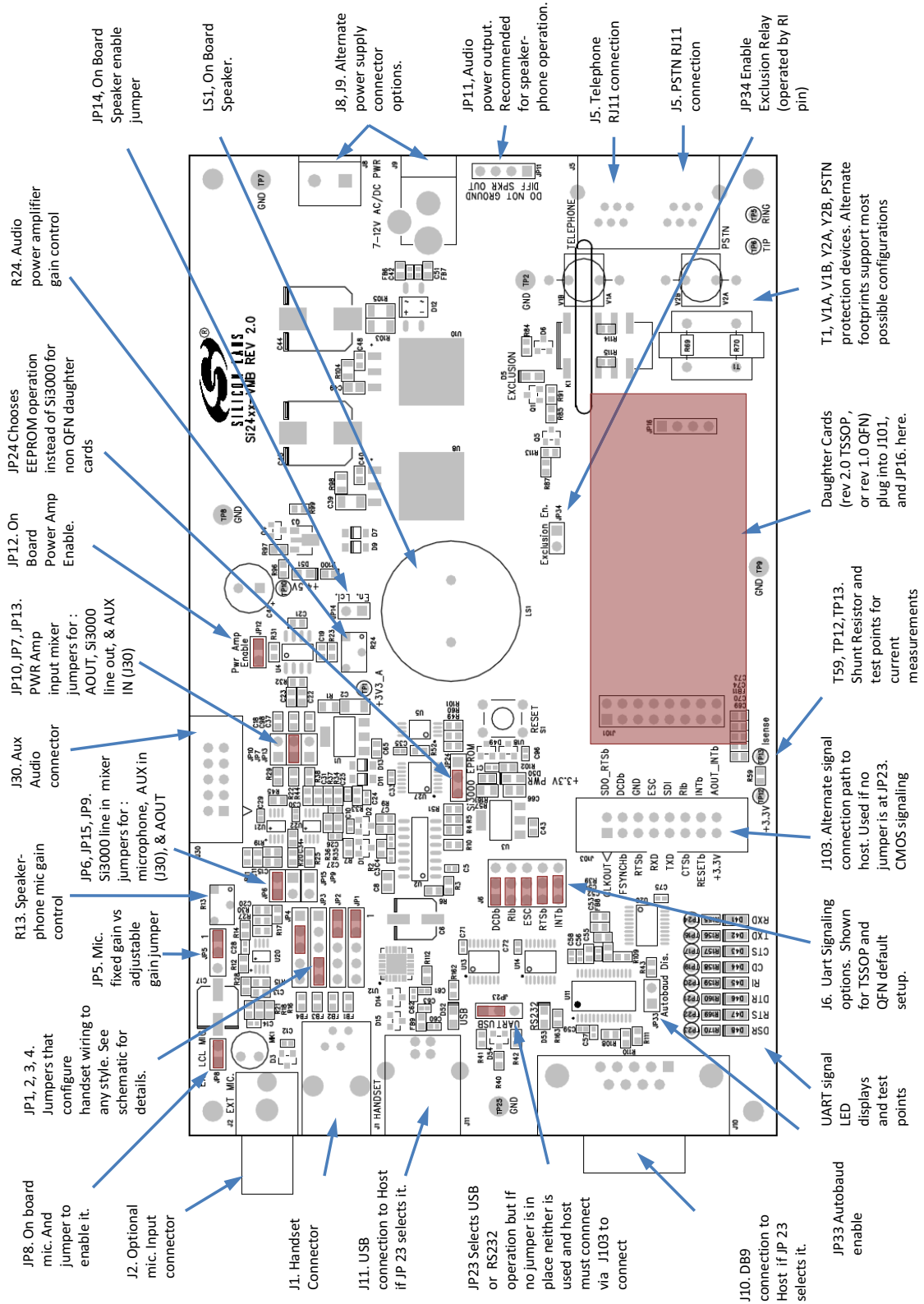

Figure 5. Function and Location of Global Voice ISModem EVB Jumpers

Si2494/39/38/37/36/35/29/19/18/17FT18-EVB

Table 2 explains the use of the data related jumpers. It also shows the default state.

Check all jumper settings on the EVB before applying power.

These default data related jumper settings shown below configure the EVB for USB serial operation with auto baud as a default. Any terminal emulator program configured to communicate through the virtual com port created by the provided driver can be used to communicate with the EVB. There are no BAUD settings required since the modem has an auto baud feature.

The USB virtual com port drivers needed for the USB link to work are on the provided CD.

Customers that want to use an RS232 port only need to change JP23 and connect an RS232 cable to the host. As with the USB configuration, any terminal emulator program configured to communicate through a PC COM port can be used to communicate with the EVB.

Although the user can exercise many of the modem commands (including voice features) using a terminal emulator program, a fax driver is required to implement fax send/receive functionality.

This EVB also provides an application, UltraCOM distributed on the CD that can act as a terminal emulator and as a sound feature demonstration vehicle. See Appendix I for an UltraCOM quick start guide that shows how to run this demonstration.

Table 2. Digital Data Related Jumpers

Jumper Number	Pins Jumped	Default State	Comments
JP23	1-2	✓	USB selected
	2-3		UART selected
J6	1-2, 4-5, 7-8, 10-11, 13-14	✓	Typical Si2438/37/36/35/29/19/18/17 FT setup (24 pin pkg)
JP33	1-2		Disable Auto baud
JP24	1-2		Enable EEPROM
	2-3	✓	Enable Si3000

Si2494/39/38/37/36/35/29/19/18/17FT18-EVB

Table 3 explains the use of the analog audio oriented jumpers and adjustments, while showing the default state. These jumpers and adjustments can be used to tailor the operation of the global fax EVB so that it interfaces well with the users host system and provides the maximum flexibility as the choice of loudspeaker microphone and alternate sources of sound.

Table 3. Sound Related Jumpers

Jumper Number	Pins Jumped	Default State	Comments
JP34	1-2		Enable Exclusion Relay
JP1	1-2	✓	Handset pin 4 connection (ground)*
JP2	1-2	✓	Handset pin 3 connection (ground)*
JP3	4-5	✓	Handset pin 2 connection (earpiece signal)*
JP4	2-3	✓	Handset pin 1 connection (mouthpiece signal)*
JP24	1-2		Enable EEPROM (factory use only)
	2-3	✓	Enable Si3000
JP5	1-2	✓	Variable mic gain = 6 to 34 dB
	3-3		Fixed mic gain = 21 dB
JP6	1-2	✓	Mic to input mixer
JP15	1-2		External Line In to input mixer
JP9	1-2		AOUT to input mixer
JP8	1-2	✓	Connects on board mic
JP10	1-2		AOUT to power amp mixer
JP7	1-2	✓	Si3000 line out to power amp mixer
JP13	1-2		Aux Input to power amp mixer
JP14	1-2		On Board Speaker connected
JP12	1-2	✓	Enable Pwr Amp.
*Note: For typical Cisco handset.			

3.2. I/O and Adjustments

Table 4 explains the use of the adjustable analog audio-oriented controls as well as their default state.

Table 4. Audio Adjustments

Ref	Default State	Comments
R13	4 turns CW	Mic Preamp Gain 6 dB to 34 dB
R24	CCW(21.4 dB)	Power Amp Gain 21.4 dB to 46.4 dB WRT line out

3.3. USB Interface Data Link Setup Quick Start

1. Set jumpers according to the default configuration shown in Table 2 on page 7.
2. Connect:
 - Install USB cable and provided driver.
 - RJ-11 to phone line or test box.
3. Open the terminal emulator program, and apply power to the EVB.
4. Select the serial COM channel used.
5. Type "AT" followed by a carriage return. (Autobaud automatically adjusts modem DTE speed and protocol.). The modem should echo "AT" and then send the "OK" response code.
6. Type ATH1 and ATH0 to seize and release the telephone line.

3.4. UltraCOM Installation Instructions

Perform the following steps:

1. Double-click the ultracom.msi file to launch the installer. Click Next.

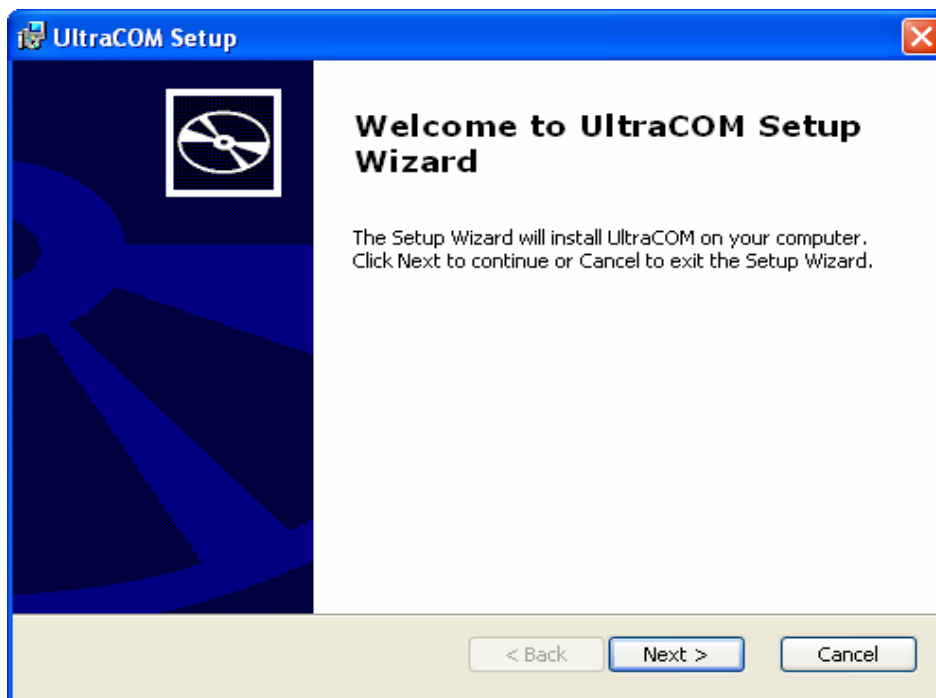

Figure 6. UltraCOM Setup Wizard

2. Accept the default installation path and click Next.

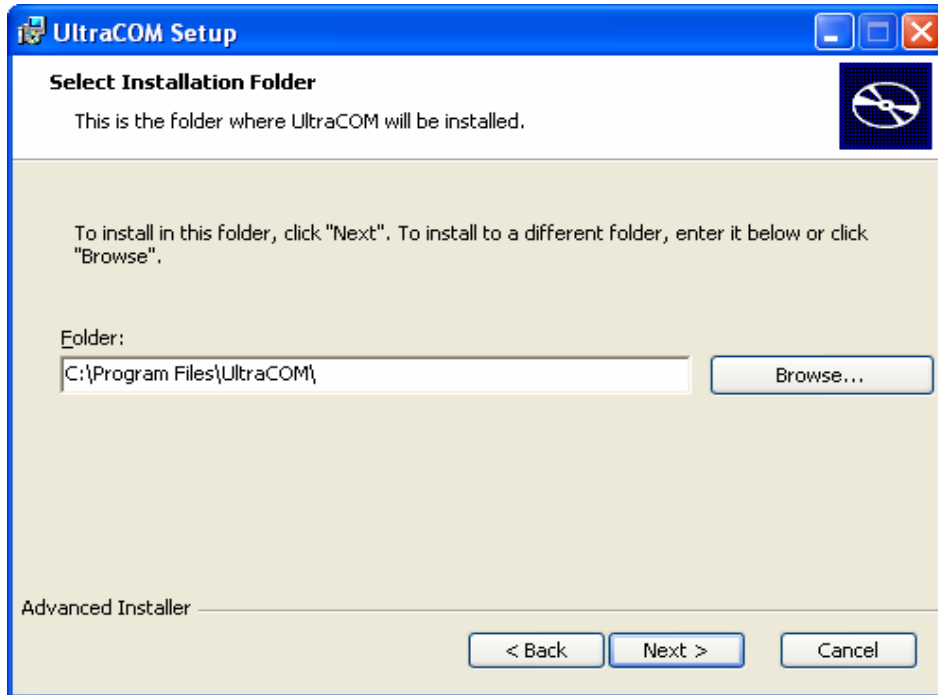

Figure 7. Select Installation Folder Dialog Box

3. Click Install to start the installation.

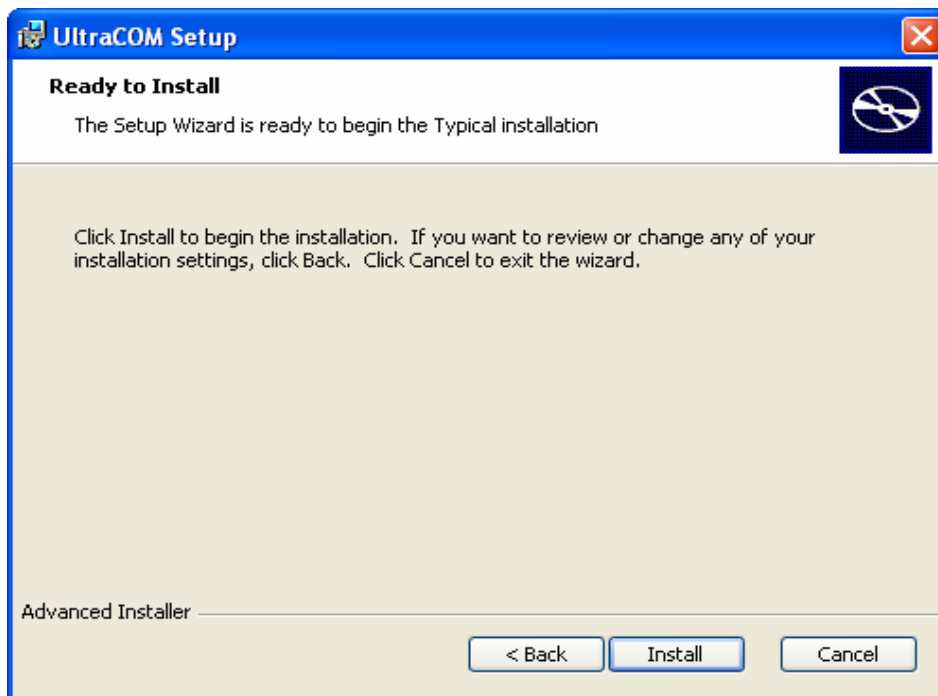

Figure 8. Install Dialog Box

4. After installation is complete, click Finish to close the installer.

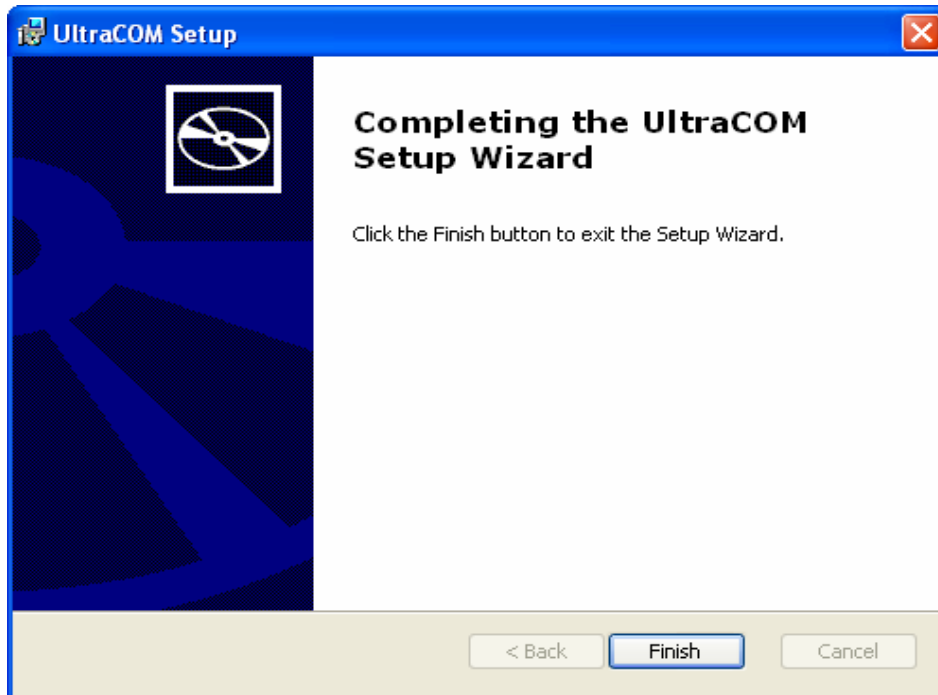

Figure 9. Completing UltraCOM Setup Wizard

5. UltraCOM may be launched from the desktop link or from the Start menu:
Start Programs→UltraCOM→UltraCOM
6. From the UltraCOM main menu, select Help Index. This will load the help file.
7. Select the Quick Start link from the main menu and review the information.

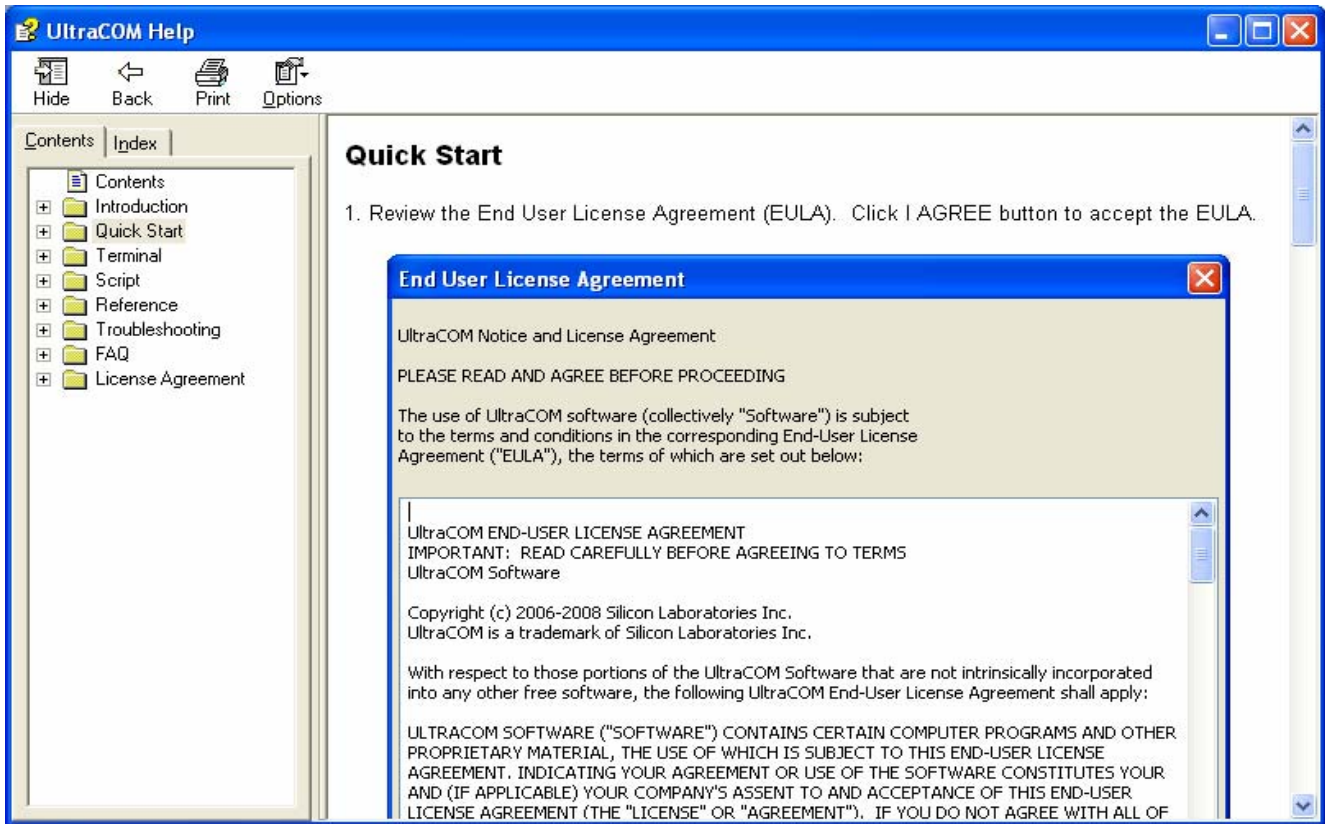

Figure 10. Quick Start

3.5. USB Interface Data Link Setup Quick Start

1. Set jumpers according to the default configuration shown in Figure 5.
2. Install the USB driver for your operating system from the CD supplied with the evaluation board.
3. Connect:
 - USB cable to PC
 - RJ-11 to phone line or test box
4. Open the terminal emulator program.
5. Select one of the USB Virtual Com Port numbers in the emulator program's user interface.
6. Type "AT" followed by a carriage return. (Autobaud automatically adjusts modem DTE speed and protocol.) The modem should echo "AT" and then send the "OK" response code.
7. Type ATH1 and ATH0 to seize and release the telephone line.

3.6. Sound Demonstration Using UltraCOM Quick Start Guide

Step 1: Perform the Quick Start USB Interface Data Link Setup Quick Start

1. Set jumpers according to the default configuration shown in Figure 5.
2. Install the USB driver for your operating system from the CD supplied with the evaluation board.
3. Connect:
 - USB cable to PC
 - RJ-11 to phone line or test box.
4. Open the terminal emulator program.
5. Select one of the USB Virtual Com Port numbers in the emulator program's user interface.
6. Type "AT" followed by a carriage return. (Autobaud automatically adjusts modem DTE speed and protocol.). The modem should echo "AT" and then send the "OK" response code.
7. Type ATH1 and ATH0 to seize and release the telephone line.

Step 2

Add connections to a loudspeaker and a handset as shown in the following diagram.

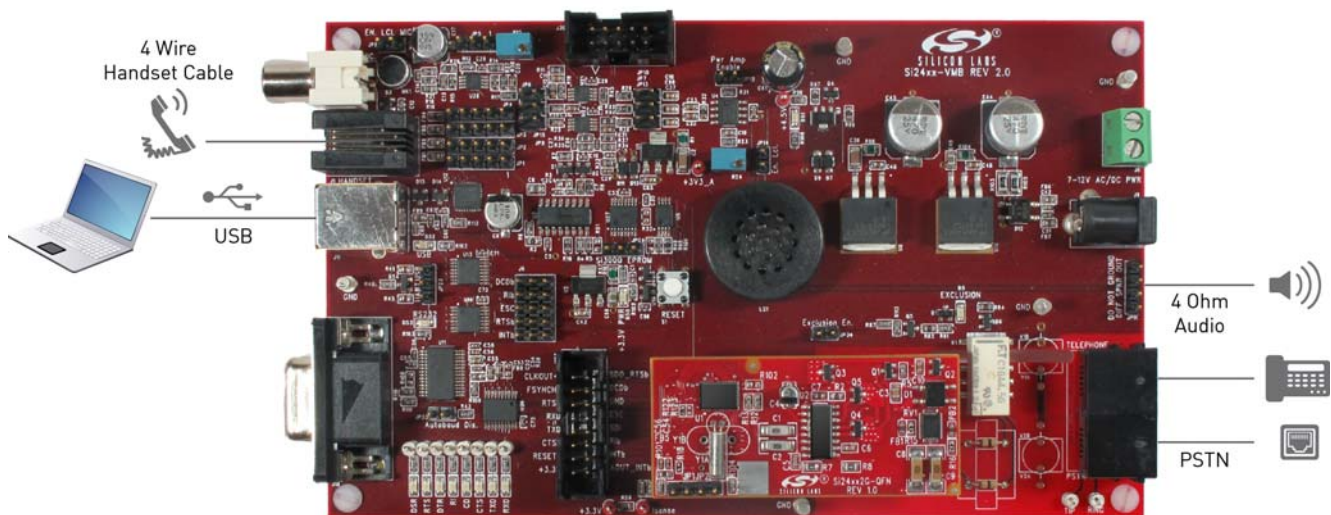

Figure 11. Sound Demonstration Hardware Interconnect Guide

Step 3:

1. Install UltraCOM (provided in this kit) on Windows XP
2. Launch UltraCOM.

Si2494/39/38/37/36/35/29/19/18/17FT18-EVB

Step 4:

Select "Terminal-Open" making sure the serial configuration is as shown (except for port selection), then select OK.

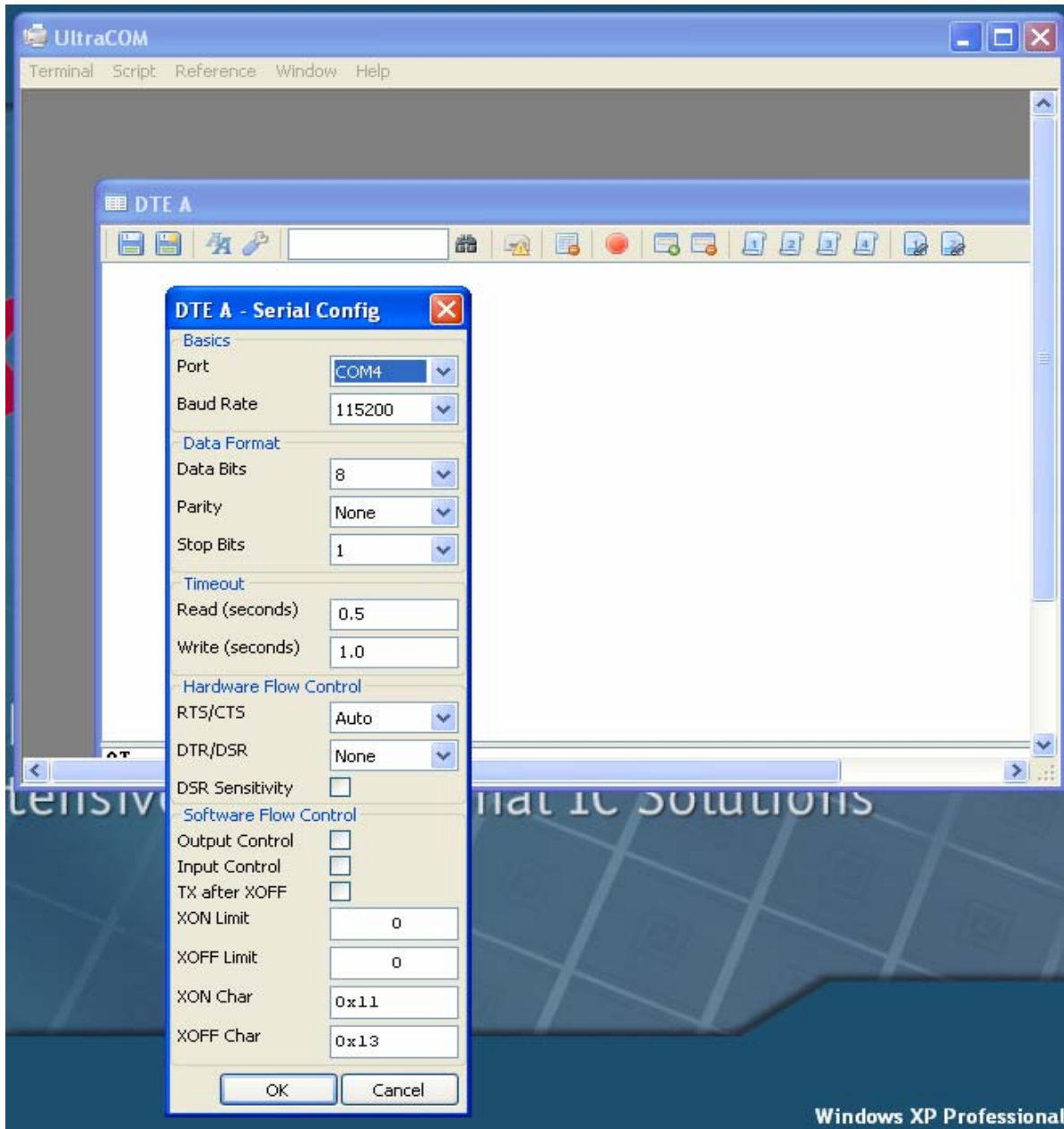

Figure 12. UltraCOM Serial Configuration Dialog Box

Step 5:

1. Select Open Plug-In (The Green Icon) in the screen snapshot that follows.
2. Respond OK to "Load Plug-in" "24xx Voice Functions"

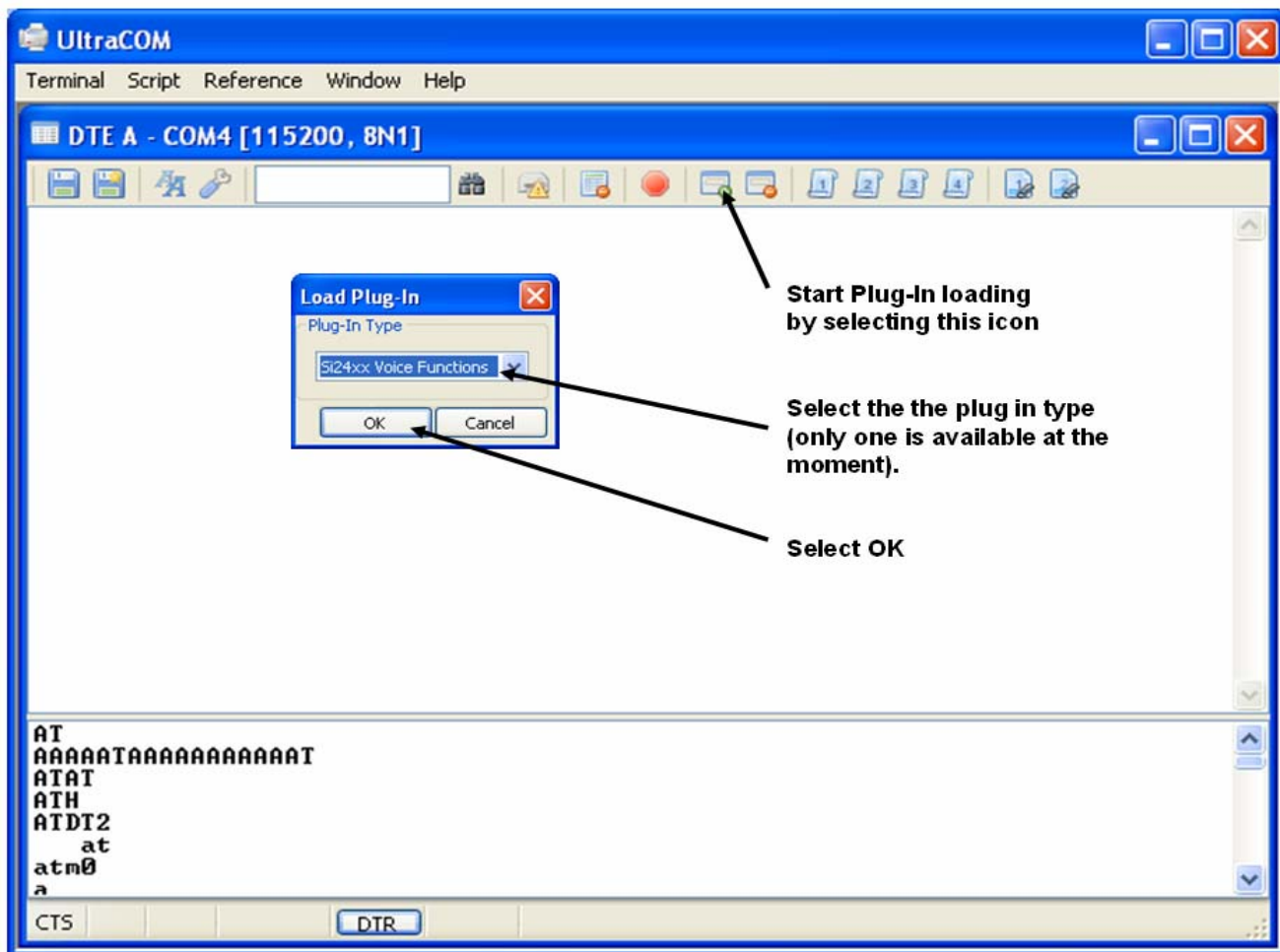

Figure 13. UltraCOM Load Plug-In Dialog Box

Si2494/39/38/37/36/35/29/19/18/17FT18-EVB

Step 6:

Wait for the screen below to open and the patch to load.

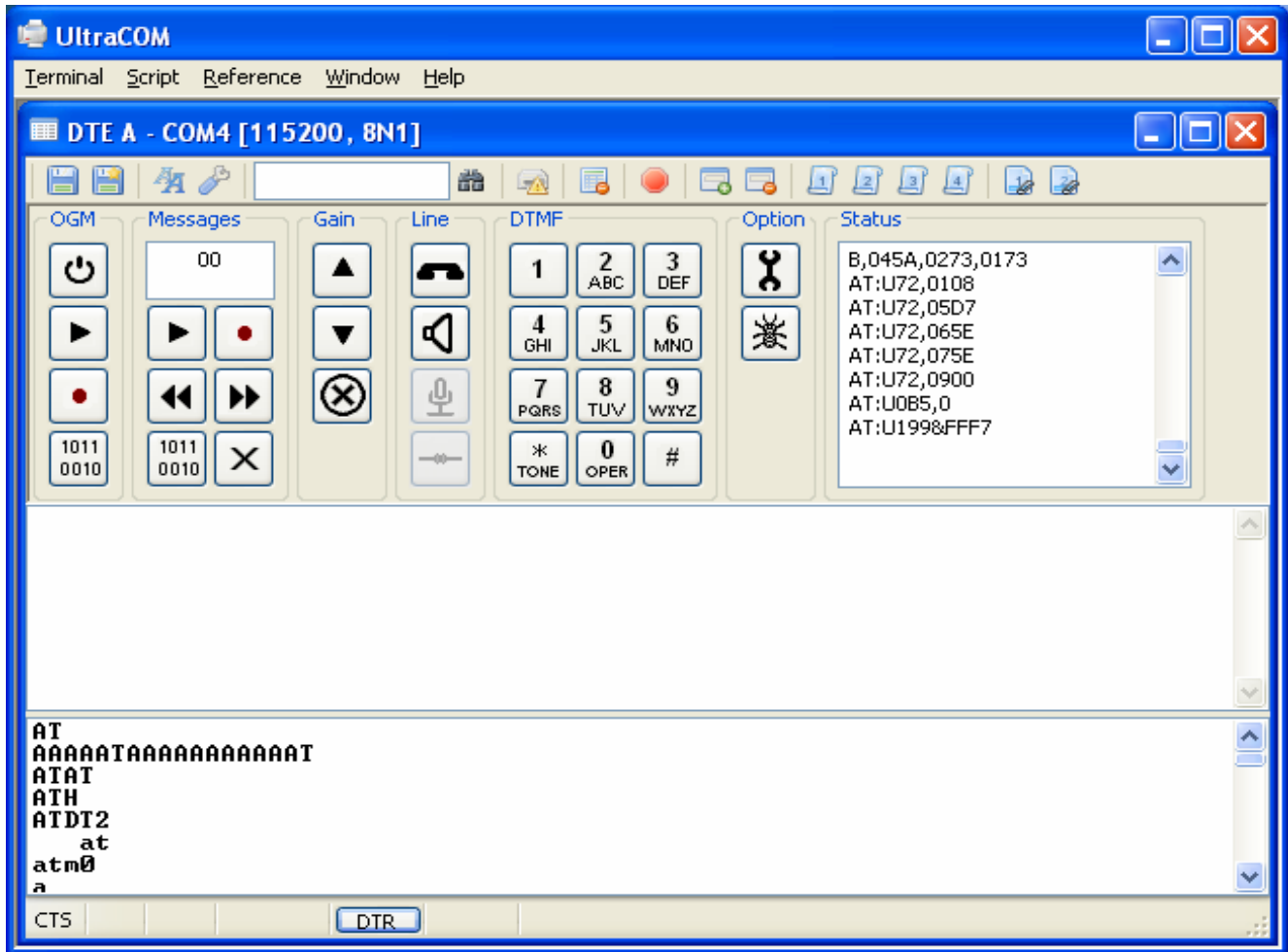

Figure 14. UltraCOM Plug-Ins Patch Load Phase

Step 7:

Use the interface above to do the following:

- Go off hook with the handset by selecting the handset symbol
- Select the speakerphone button to start that mode.
- Dial a DTMF number.
- Note the following suggestions.
 - Use the external off-board speaker for speakerphone functionality
 - Use the on-board electret for the microphone.
 - Use the PSTN, a PBX or a Line Simulator for the phone line.

How to Change the Patch Used in the UltraCOM Plug-In

1) Load Plug In by selecting the Plug-In's icon

2) Select Preferences Icon (the wrench)

3) Select ISModem Options Tab

4) Select Patch Tab

5) Cut and Paste a new patch Text into this editable area, replacing the old patch between the lines:

```

ATZ
ATE0+FCLASS=0
AT+IFC
AT+PF000,7b5d,4dc,7b5f,4de,7b59,4d8,7b5b,4da
AT+PF006,7b55,4d4,7b57,4d6,7b51,4d0,7b53,4d2
AT+PF010,7b4d,4cc,7b4f,4ca,7b49,4c6,7b4b,4c4
AT+PF018,7b45,4c4,7b47,4c6,7b41,4c0,7b43,4c2
AT+PF020,fc9a,fc8c,4f9,7f3c,fb78,4499,fae4
AT+PF027,4d6d,f99b,f995,42f2,4204,f99b,f995
AT+PF02e,42d2,4f2,7ebc,fcad,637e,fc07,4eb0
AT+PF035,fae4,fafa,4eb7,75c9,fa11,fa1b,75d1
AT+PF03c,7576,fa3b,fa3e,752a,49d,48e,49f,3c5
AT+PF044,7f5e,48a,498,3c1,fc0c,c795,65ef,484
AT+PF04c,e391,fc0c,65eb,496,e28d,fc09,c586
AT+PF053,2681,6709,c86,c586,92,c8d7,f594,e19c
AT+PF05b,5cda,c58f,810b,6703,8482,b8bd,55c8
AT+PF069,8942,6637,48c,c58f,8941,6633,fc81
AT+PF070,abf5,8458,b6f7,4ae,7a20,e2e9,8925
AT+PF0e2,e3af,fc3e,b8c5,6b60,e133,fc3a,c5bb
AT+PF07e,6723,cad,c553,2687,b6df,45e,c557,2689
AT+PF077,c6eb,c5ab,8452,6727,4af,c5af,8451
AT+PF080,6723,cad,c553,2687,b6df,45e,c557,2689
AT+PF086,b6db,269b,ab45,2682,c559,46ca,7bd1
AT+PF08d,e149,c752,b85a,763c,e144,fcda,673f
AT+PF094,451,b84b,353f,e29a,946c,c745,4036
AT+PF09b,e346,fcab,c741,4835,e242,fc97,660a
AT+PF0a2,444,b802,ac21,848c,b87b,78fa,9578
AT+PF0b9,416,e174,24e,fc03,ac20,b89e,b6b6,41b
AT+PF0b1,b606,43f,b605,469,b600,475,b677,b67b
AT+PF0b9,464,b672,465,b861,67d3,267,c680,3d67
AT+PF0c1,c6a6,369a,c517,16d7,b6f0,ab3,b6fa
AT+PF0c6,fcfc,b694,417,c6a3,19,c642,fc13,dfcc
    
```

6) Select OK

7) Close the Preferences Dialog Box and Plug-In, then open the Plug-In again

Figure 15. UltraCOM Plug-In Patch Changing

3.7. Power Requirements

The EVB has an onboard diode bridge, filter capacitor, and voltage regulators. Power can be supplied from the USB connection or a source capable of providing 8.5–13.5 V dc or 6–9.5 VRMS peak ac and at least 300 mA. A suitable wall mounted 9 V supply is provided with the kit.

Of the 300 mA required current 200 mA is used to drive the loudspeaker and may be removed from the requirement if the power amp is enabled by placing a jumper on JP12.

Power may be applied to the Voice ISModem EVB through the screw terminals, J8, the 2 mm power jack, J9, or the USB cable. The modem cable may be used to supply power even if the modem is configured for RS-232 operation.

The power consumed by the audio section is limited with an active limiter. This circuit will protect the power sources when the sound is overdriven or if the amplifier output is shorted. The power amplifier is also naturally protected with thermal limiting. Digital operations such as host to modem serial data transfer or the modem telephone line operations are unaffected by the limiter operation.

Note that the modem will take power from wherever it finds it and that it is possible to use the RS232 port for signaling and the USB for power or to use the USB for signaling and to provide power through the provided external 9 V supply.

Si2494/39/38/37/36/35/29/19/18/17FT18-EVB

3.8. EVB Part Numbers

The Voice ISModem evaluation boards are offered in multiple versions. The first four numbers indicate the system-side device. The options include speed and various audio capabilities as well as package and temperature. See Figure 16:

Si2438FT18-EVB
Si2437FT18-EVB
Si2436FT18-EVB
Si2435FT18-EVB
Si2419FT18-EVB
Si2418FT18-EVB
Si2417FT18-EVB
Si2494AFM18-EVB
Si2439AFM18-EVB

Figure 16. EVB Part Number Example

4. Voice ISModem EVB Functional Description

The Voice ISModem EVB is a multipurpose evaluation system. The modem daughter card illustrates the small size and few components required to implement an entire controller-based modem with global compatibility. The daughter card can be used independently of, or in conjunction with, the motherboard. The motherboard adds features that enhance the ease of evaluating the many capabilities of the Si24xx ISModem.

4.1. Motherboard

The motherboard provides a convenient interface to the Si24xx ISModem DC (daughter card). The versatile power supply allows for a wide range of ac and dc voltages to power the board.

A versatile digital IO system allows either a USB virtual com port to be used to interface to the board or an RS-232 transceivers with a DB9 connector allowing the EVB to be easily connected to a PC or other terminal device. A jumper option allows direct access to the LVCMOS/TTL level serial inputs to the Si24xx, bypassing the RS-232 transceivers or USB interface. This is particularly useful for directly connecting the Si24xx to embedded systems.

The motherboard provides connectivity to a telephone line or a phone extension via a pair of RJ11 connectors. The extension connector may be actively excluded by an onboard relay.

A switch and a connector is provided on the motherboard that is read by the modem firmware and can perform the hookswitch function.

The motherboard also contains a complete sound system including microphone, loudspeaker and handset connector. The sound system includes easy to adjust gain controls and extra inputs that allow system generated noises to be added to the sound.

A functional block diagram of the system as a whole can be seen below.

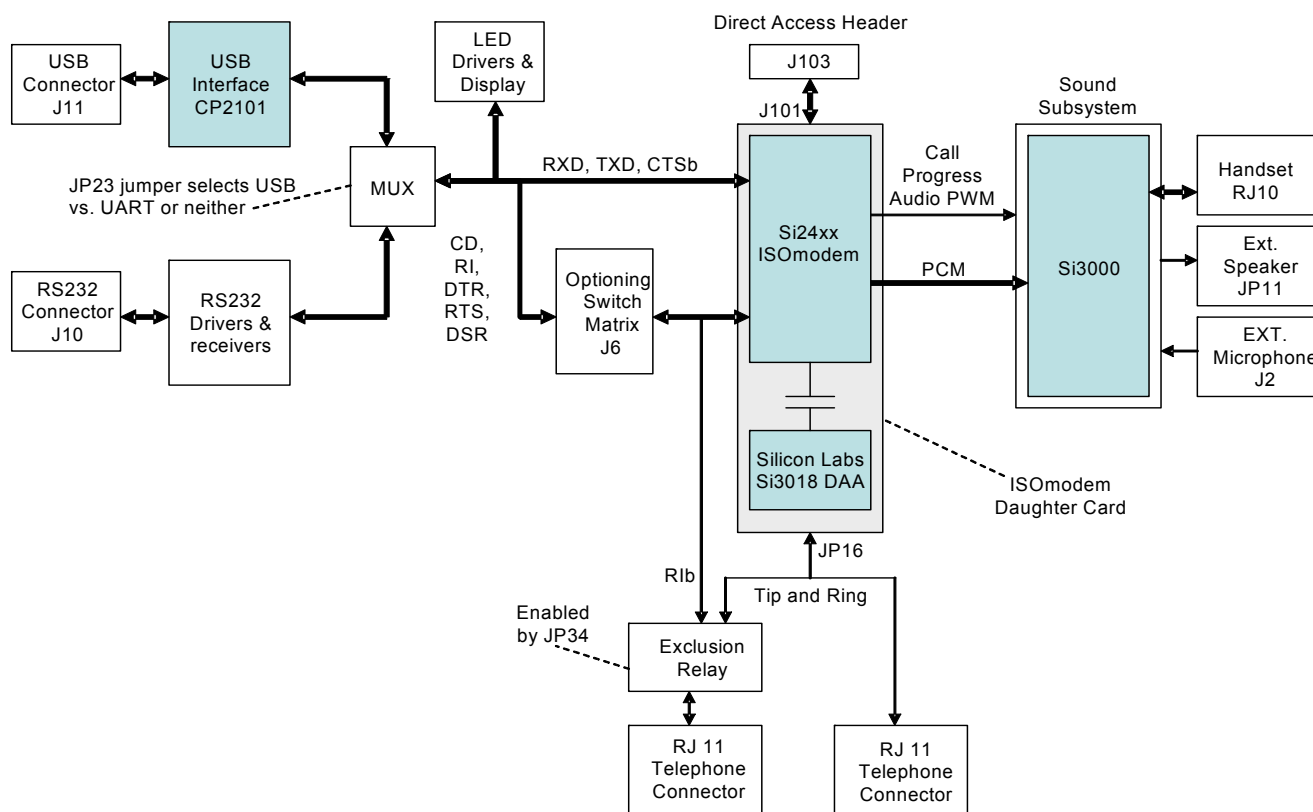

Figure 17. Sound System Block Diagram

Si2494/39/38/37/36/35/29/19/18/17FT18-EVB

4.1.1. Power Supply

4.1.1.1. Power Distribution

The power distribution diagram for the global voice EVB can be seen in Figure 18 below. Analog and Digital voltages are separately regulated while the audio power amplifier supply is current limited to prevent accidental overload and disruption of the digital supplies.

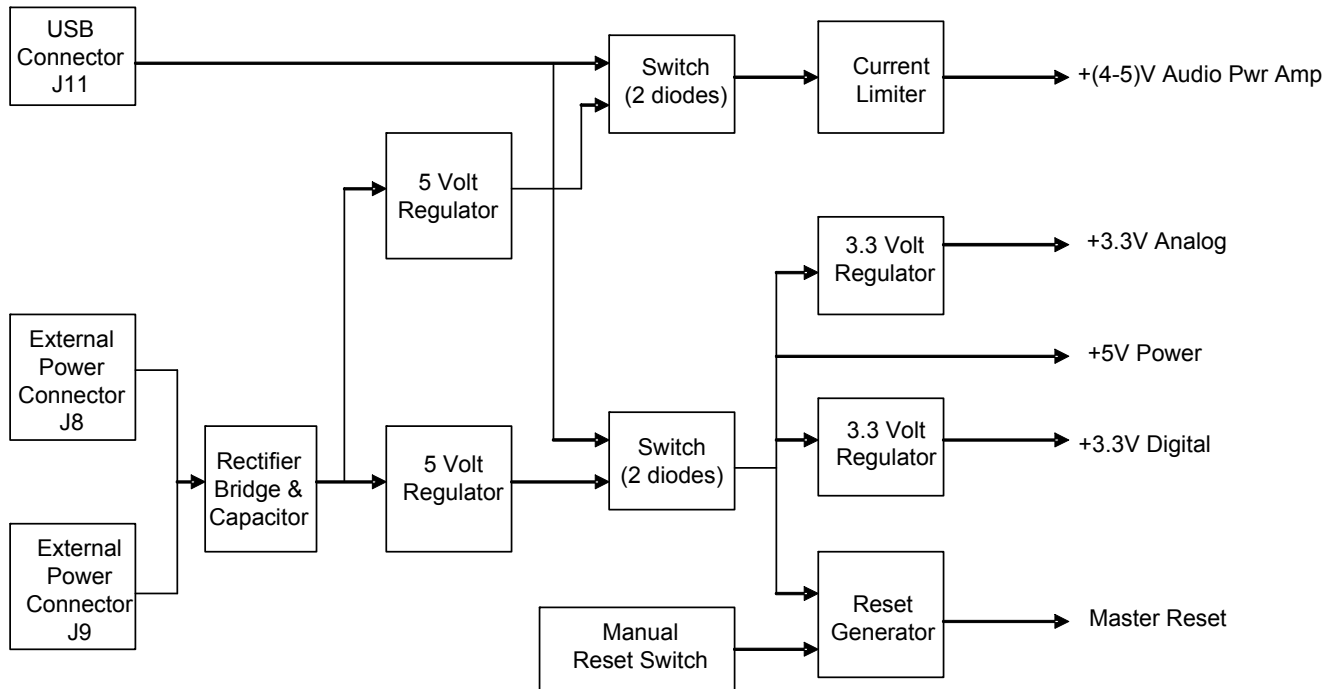

Figure 18. Power Distribution Diagram

The onboard full-wave rectifier and filter ensure the correct polarity is applied to the Voice ISOmodem EVB.

Daughter card 3.3 V power is supplied through voltage regulator U3. Daughter card current can be measured by connecting a DVM across R59, a 1 Ω current sensing resistor in the 3.3 V supply line to the daughter card.

The input voltage to either J8 or J9 must be between 8.5 and 13.5 V dc, or 6 and 9.5 VPEAK ac. The motherboard includes a diode bridge (D12) to guard against a polarity reversal of the dc voltage or to rectify an ac voltage. The power source must be capable of continuously supplying at least 100 mA. The voltage regulator, U10, can provide 5 V for the motherboard and the input for voltage regulator U3, which outputs 3.3 V for use on the motherboard and to power the daughter card. Alternately, power may be supplied to U3 through D11 from the USB port.

The power consumed by the audio section is limited with an active limiter. This circuit will protect both power sources and the audio amplifier when the sound is overdriven or if the amplifier output is shorted. Digital operations such as host to modem serial data transfer or the modem telephone line operations are unaffected by the limiter operation.

Two indicator LEDs indicate main power (+5 V) and audio amp power (~+4.5 V). See Figure 15 for locations. You will notice the one for the audio power blinking when audio is loud and clipping. This is normal.

4.1.2. Reset Circuitry

The Si24xx requires a reset pulse to remain low for at least 5.0 ms after the power supply has stabilized during the power up sequence or for at least 5.0 ms during a power-on reset. Most production Si24xx modem chipset applications require that RESET be controlled by the host processor. Certain Si24xx operation modes, including power down, require a hardware reset to recover.

The Voice ISOModem EVB contains two reset options, an automatic power-on reset device, U18 (DS1818) (default), and a manual reset switch (S1) to permit resetting the chip without removing power. A reset, regardless of the mechanism, causes all modem settings to revert to factory default values.

4.1.3. DS1818

The DS1818 is a small, low-cost device that monitors the voltage on VD and an external reset pushbutton. If VD drops below 3.0 V, the DS1818 provides a 220 ms active-low reset pulse. On power up, the DS1818 also outputs an active low reset pulse for 220 ms after VD reaches 90% of the nominal 3.3 V value. The DS1818 outputs a 220 ms reset pulse any time the power supply voltage exceeds the 3.3 V 10% window.

4.1.4. Manual Reset

The manual reset switch (S1) performs a power-on reset. This resets the Si24xx to factory defaults without turning off power. Pressing S1 activates the reset monitor in the DS1818 and produces a 220 ms active low reset pulse.

4.1.5. Interface Selection

The serial interface of the Voice ISOModem EVB can be connected to a computer, terminal, embedded system, or any other data terminal equipment (DTE) via a standard RS-232 interface, USB interface, or through a direct TTL serial interface.

At the heart of this capability is the MUX and the jumper that controls it: JP23.

Table 5. Board Configuration

JP23	Modem Signalling Done Via
X	Header, J103
1–2 Jumped	USB Port
2–3 Not Jumped	Serial Port

4.1.5.1. RS-232 Interface

The serial cable connects to J10 on the motherboard and provides a data link the PC or embedded host processor. Moving the jumper on JP23 enables the RS232 interface or the USB interface.

The Maxim MAX3237 transceiver interfaces directly with the TTL levels available at the serial interface of the Si24xx and, using internal charge pumps, makes these signals compatible with the RS-232 standard. The RS-232 transceiver on the Voice ISOModem EVB can communicate at rates between 300 bps and 1 Mbps. This simplifies the connection to PCs and other data terminal equipment (DTE).

The signals available on the Voice ISOModem EVB serial interface (DB9 connector) are listed in Table 6 along with the various signal names used and both connector pin numbers and ISOModem package pin numbers.

Table 6. DB9 Pin Connections (J10)

J10 Name	J10 Symbol	J10 Pin	ISOmodem Pin Number	ISOmodem Signal Name
Carrier Detect	CD	1*	See Note*	DCD/EESD
Received Data	RXD	2	9	RXD
Transmit Data	TXD	3	10	TXD
Data Terminal Ready	DTR	4*	See Note*	ESC/RI
Signal Ground	SG	5	6	GND
Data Set Ready	DSR	6*	See Note*	INT/AOUT
Ready to Send	RTS	7*	See Note*	RTS/RXCLK
Clear to Send	CTS	8	11	CTS
Ring Indicator	RD	9*	17	RI
*Note: JP6 jumper option.				

4.1.5.2. USB Interface

The USB cable connects to J11 on the motherboard and provides both data and power.

This operation mode uses the standard factory jumper settings illustrated in Table 2 on page 7.

Installing a jumper on J23 enables the USB interface and disables the RS-232 interface. The USB interface is provided by U12. A USB driver for this chip is available for most PC and MAC operating systems on the CD.

4.1.5.3. Direct Access Interface

The direct access interface header (J103) can be used to connect the motherboard to an embedded system.

If J103 is used in this manner, it is necessary to remove the jumper from JP23 to disable both the RS-232 and USB interface and prevent signal contention. See Table 5.

In this mode, the motherboard continue to supply a few other signals and functions such as power (derived from J8, J9, or USB) as well as a power-on reset signal and the telephone line connection via the exclusion relay contact and the RJ-11 jack connected to the modem line side.

J103 provides access to all the ISOmodem system side signals available on the daughter card.

If the user wishes to go further and use his embedded system's power supply or reset line, he can remove the daughter card from the mother board and integrate it directly into his system.

4.1.6. Exclusion Relay

The exclusion relay (Figure 19) on the motherboard allows the modem to turn on the relay and exclude the phone line connection from an auxiliary device such as a telephone connected to the second RJ11 socket. The relay is enabled via jumper JP34.

The control signal used is the one called R1b and is managed by special command sequences (see application notes AN93 or AN244). R1b goes low to turn on the relay via a driver transistor.

See the diagram below for the location of the connectors and the relay.

Note that the R1b signal must be kept high during the reset pulse, due to the use of this pin for special manufacturing functions. This demands that this pin drive either an NMOS relay driver transistor or a 3.3 V referenced buffer like the one used here.

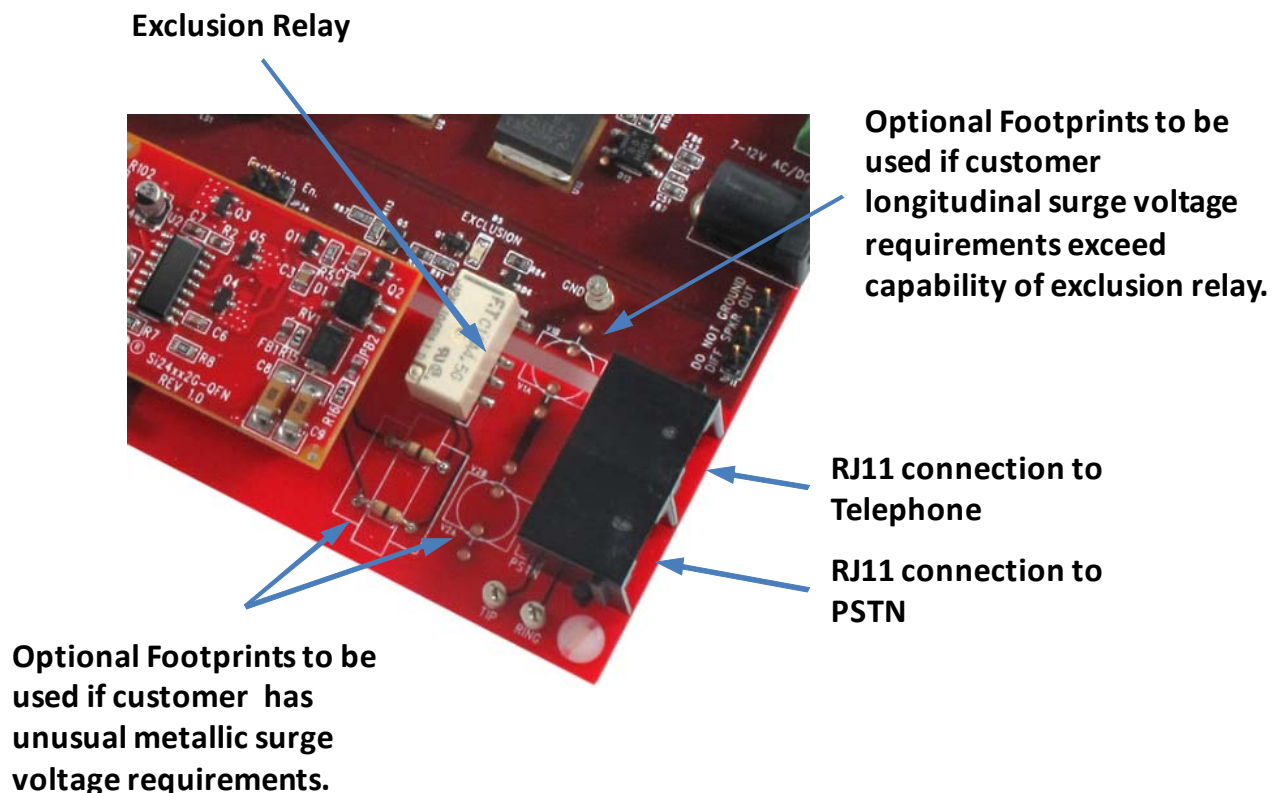

Figure 19. Exclusion Relay and Surge Protection

Si2494/39/38/37/36/35/29/19/18/17FT18-EVB

4.1.7. Surge Protection Circuits

This evaluation board is designed to provide several possible levels of surge protection.

The ISOModem alone does not need surge protection for a global implementation except for the components normally selected and implemented on the daughter card. These are the P3100B sidactor and the Y2 caps used for C1, C2, C8, and C9.

There are two basic reasons a customer may enhance this surge protection. The first is to protect the telephone exclusion relay, which often does not meet the same surge capability of the Y2 caps, and the second is to meet enhanced requirements put forth by customers and/or corporate guidelines.

Thus, footprints for either low-current 800 V or 1 kV high-current longitudinal GDTs are in place on the board (see Figure 20) to protect either the typical 2.5 kV exclusion relay or the 5 kV capacitors on the daughter card. But, note that the relay used on this motherboard is 5 kV rated (as are the capacitors) and does not need special protection. Regardless of which GDT is used by the customer, it is required to stay at 1 kV or less to control stress on the ISOModem during the GDT arcing process.

For extra metallic protection where higher current surges are mandated, a GDT combined with a common-mode choke acting as a delay element is recommended. The choke protects the Sidactor due to its leakage inductance, allowing the metallic GDT to fire first. There are two possible GDTs shown in Figure 20, and the optimal one can be chosen by the trading of cost for current carrying capacity. When populated with capable ceramic parts, the motherboard and modem can survive 15 kV/ 2 Ω, 1.2/50 μs combination waveform, i.e. 7.5 kA surge current.

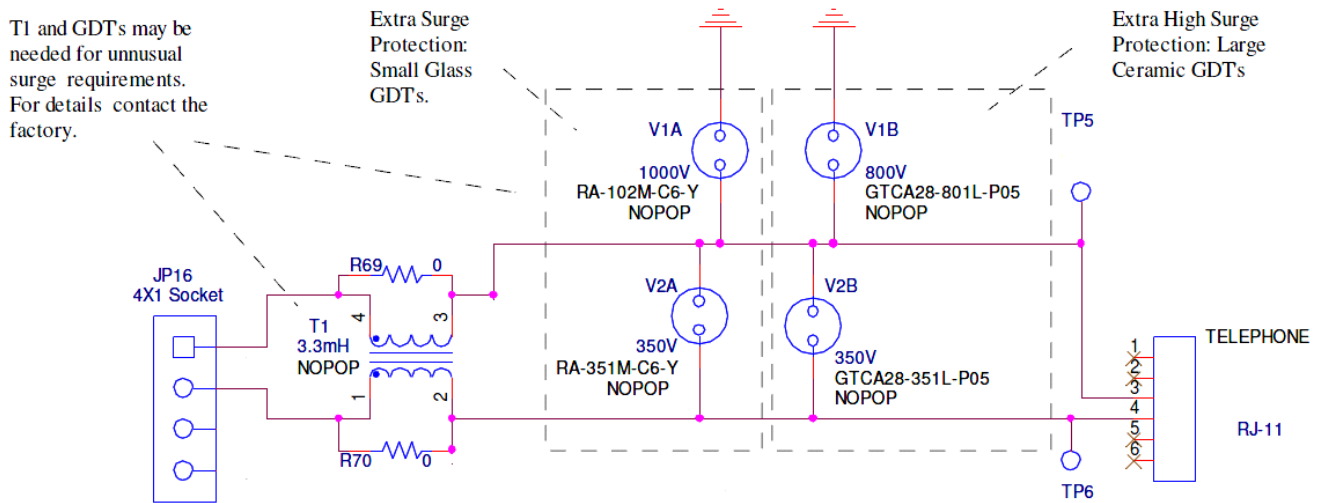

Figure 20. Optional Surge Protection Enhancement Circuits

4.1.8. The Sound System

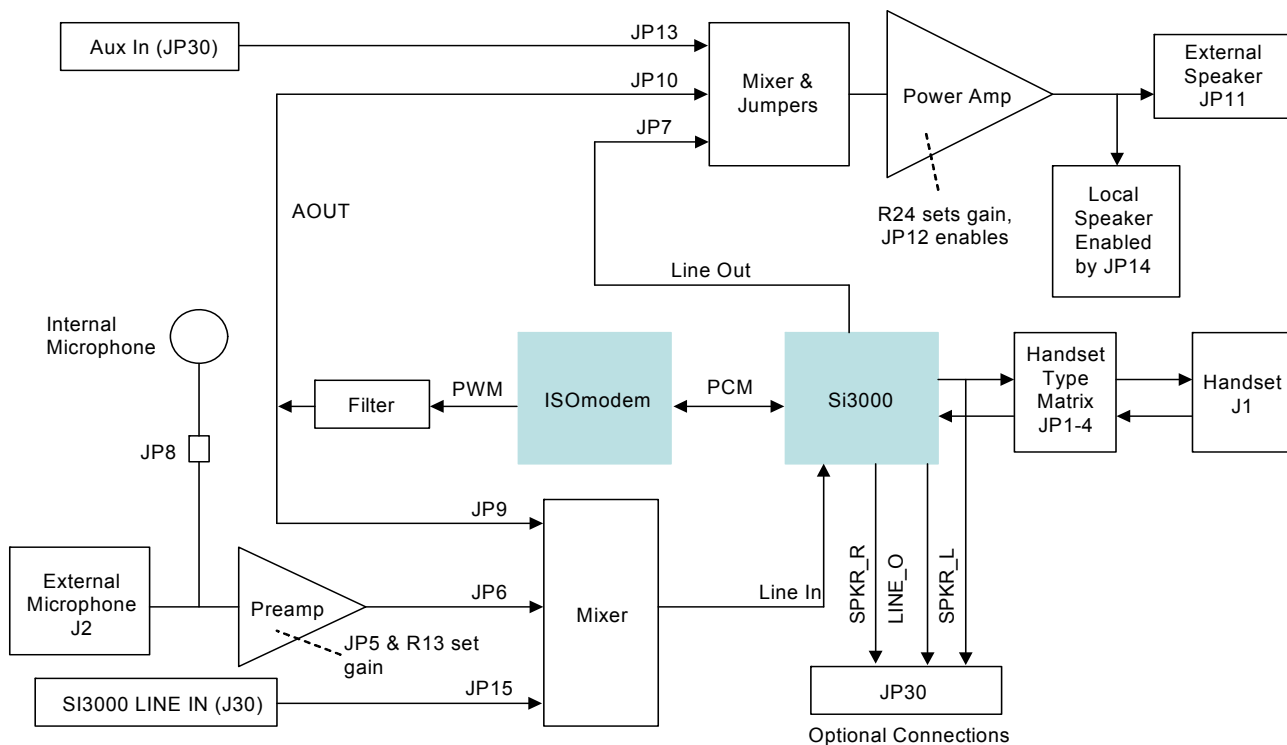

Figure 21. Sound System

The sound system on the board is centered around the Si3000 code chip shown in the above diagram, and is designed to demonstrate handset operation as well as speakerphone and telephone answering machine operation.

The Si3000 links to the ISModem via a PCM bus that allows the transfer of audio between the modem and the various audio "peripherals" that the Si3000 links to the following:

- Loudspeaker
- Handset microphone and speaker
- Microphone
- Line In
- Line Out

4.1.8.1. The Power Amplifier and Loudspeaker

The Power amplifier on the global Voice ISModem EVB can drive a 4 Ω speaker with 300 mW of audio that has 3 possible sources:

- Si3000 Line out
- Aux in, J30 signal SPKR_AUX_IN (e.g., a customer system's generated beeps or ticks)
- Call progress analog signal from modem. (ISModem's call dialing and negotiation tones)

The power amplifier itself is a low cost, rugged 3.3 V bridge device, the LM4862M. Similar parts are available from other vendors.

The sources listed above can be independently turned off by jumpers JP7, 10, and 13 or be gain controlled with no interaction, by changing the value of the summing node current injection resistors' values.

The inverted input of this chip is used as a summing junction for an audio mixer for the inputs mentioned above and with gain control effected via the feedback resistor R24.

Si2494/39/38/37/36/35/29/19/18/17FT18-EVB

The customer can change the resistor values when integrating the global Voice ISOModem EVB to his system, but should keep the RC formed by the 1 μ F input caps at a 50 Hz or higher corner to avoid a thump on turn on.

The power amplifier is enabled by JP12. This jumper can also be tied to a host signal to allow the host to shut down the amplifier.

4.1.8.2. The Call Progress Signal

The call progress tone discussed in this section comes from a PWM output pin on the ISOModem. The PWM signal is processed by a high-pass filter (see below).

When using this circuit it is important to extend the modem reset time to 10 ms. This is the time to charge C83 via the built in weak pull ups in case that the modem has been operating prior to reset and has put the AOUT into a PWM state that is 100% low. Any modifications to this circuit or reset time should be done keeping in mind the following rule: The ISOModem reset time and AOUT capacitive loading must be balanced so that the AOUT pin must have time to charge it's load to a high state.

It should be noted that when creating the call progress output with this circuit, about half the noise present in the audio bandwidth on the modem supply pins is passed along with the call progress tone. Consequently, the modem supply needs to be fairly clean.

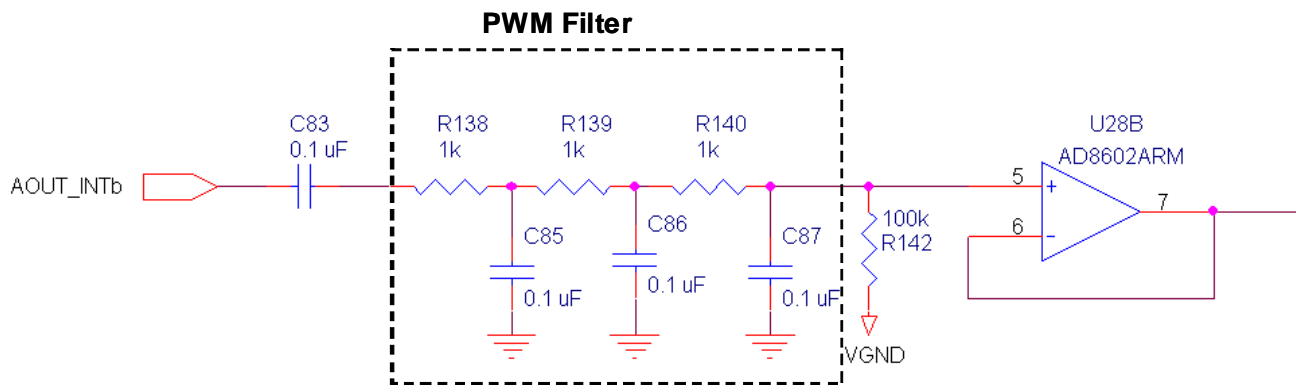

Figure 22. High-Pass Filter

4.1.8.3. The Input Mixer

An input mixer is also in the sound section of the global fax EVB. It drives the line input of the Si3000 with a mixture of the following possible sources:

- An electret microphone
- An auxiliary line input, J30 signal (Si3000_LINE_IN)
- Call progress analog signal from modem. (ISOModem's call dialing and negotiation tones)

4.1.8.4. The Speakerphone Electret Microphone

The electret microphone listed above is amplified by a preamp before this mixer. The gain of the microphone preamp can be adjusted via a potentiometer if JP5 pins 1 and 2 are jumpered, or is fixed by R12 and R15 when JP5 pins 2 and 3 are jumpered. It is intended for speakerphone use.

This electret microphone in this case can be either the microphone that comes installed on this board or an external one connected to the RCA jack J2. There is a dedicated electret power supply available to power either of these two microphones. The supply is configured so that it is easy for the user to adjust its voltage between 0 and 3.3 V by varying R27 and R30. This allows the user to most closely match the operation of his intended target. The onboard electret is enabled by JP8.

Si2494/39/38/37/36/35/29/19/18/17FT18-EVB

4.1.8.5. The Handset

The handset signals are all processed by the Si3000 chip. The board provides a matrix of connectors to allow ANY handset pin configuration to be used. This jumper array is shown in Figure 23. The default setting is shown in Table 3 on page 8.

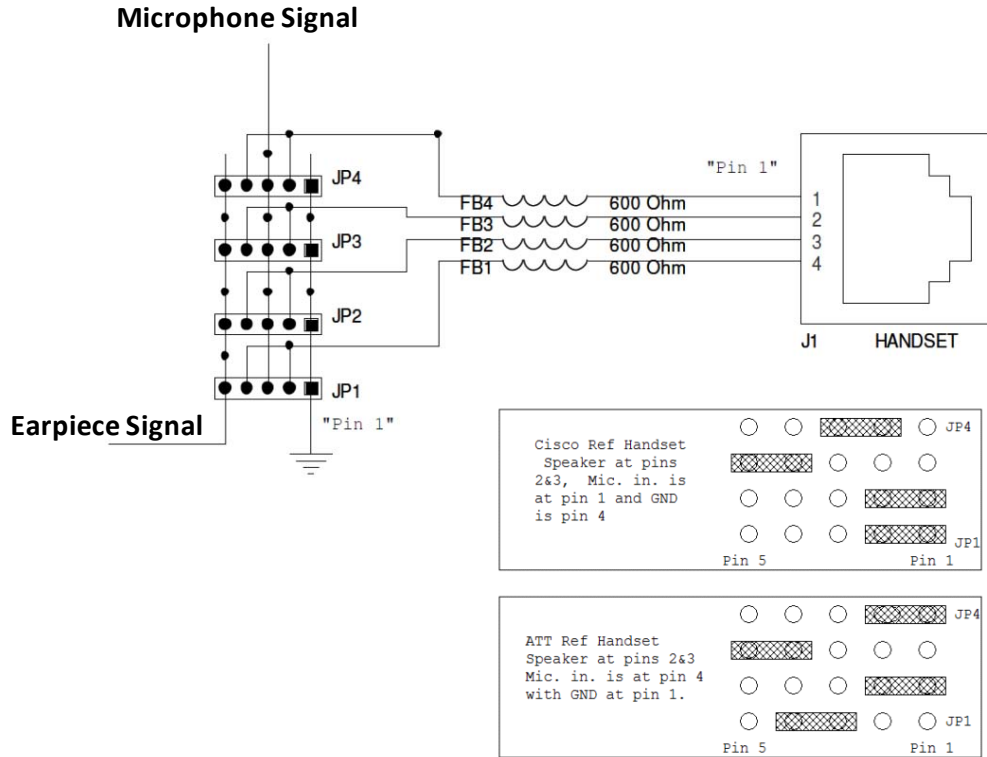

Figure 23. Handset

Si2494/39/38/37/36/35/29/19/18/17FT18-EVB

4.2. Daughter Cards

There are two types of daughter card; one is for QFN packaged modem chips, and one is for smaller packages. The daughter card itself is a complete modem solution perfectly suited for use in an embedded system.

The daughter card requires a 3.3 V supply capable of providing at least 35 mA. Be sure to provide the proper power-on reset pulse to the daughter card if it is used in the stand-alone mode.

The Voice ISModem EVB motherboard connects to the daughter card through two connectors, J101 and JP16. JP101 is an 8x2 socket providing connection to all Si24xx digital signals and a regulated 3.3 V power.

The Si24xx digital signals and power also appear at JP103 and they are LVCMOS and TTL compatible. JP103 can be used for monitoring purposes or may be used as the interface to the users host if JP23 has no jumper, thus disabling the on board digital multiplexer. In this case note that the PCM link to the Si3000 is still in place and is still connected to the daughter card signals.

JP16 is a 4x1 socket providing connection between the daughter card and both the RJ-11 phone jack and the exclusion relay on the motherboard.

The daughter cards for this global Voice ISModem EVB come with the appropriate ISModem system side chip installed and are identical otherwise. The possible ISModem system side chips are shown in Figure 24:

Si2438FT
Si2437FT
Si2436FT
Si2435FT
Si2419FT
Si2418FT
Si2417FT
Si2494FM
Si2439FM

Figure 24. ISModem System-Side Chip Part Number Scheme

The line side chip on the daughter card is the Si3018 DAA chip. It works with a few low cost discrete parts that complete the telephone line interface.

Small 33 pF capacitors link the system side to the isolated side and provide both data and power transfer to the isolated telephone line circuit.

The connection between the Si3018 chip and the telephone line is done via a diode bridge to control line polarity and beads to control EMI.

A Sidactor is placed across the phone line for surge arresting reasons, while a pair of capacitors link the tip and ring to system ground in order to minimize EMI radiation and EMI Susceptibility.

PCB layout for this circuit is somewhat critical, for link integrity, EMI, and surge reasons,. Anyone planning to design a PCB layout should check application note AN244 or AN93 and also submit the PCB design to Silicon Labs for checking. The layout used on this daughter card is shown in this user's guide.

4.2.1. Reset Requirements

The Voice ISOModem daughter card must be properly reset at powerup. The reset pin (pin 8) of the Si24xx (J101, pin 13) must be held low for at least 5.0 ms after power is applied and stabilized to ensure the device is properly reset.

4.2.2. Crystal Requirements

Clock accuracy and stability are important in modem applications. To ensure reliable communication between modems, the clock must remain within 100 ppm of the design value over the life of the modem. The crystal selected for use in a modem application must have a frequency tolerance of less than 100 ppm for the combination of initial frequency tolerance, drift over the normal operating temperature range, and five year aging. Other considerations, such as production variations in PC board capacitance and the tolerance of loading capacitors, must also be taken into account.

4.2.3. Protection

The Voice ISOModem EVB meets or exceeds all FCC and international PTT requirements and recommendations for high-voltage surge and isolation testing without any modification. The protection/isolation circuitry includes C1, C2, C8, C9, FB1, FB2, and RV1. The PCB layout is also a key "component" in the protection circuitry. The Voice ISOModem EVB provides isolation to 3 kV. Contact Silicon Laboratories for information about designing to higher levels of isolation.

4.2.4. Daughter Card Strapping and Jumper Options

Both types of daughter cards have some strapping options that are preconfigured at the factory. These are explained in the schematic and in more detail in AN93.

The QFN daughter card also has a two jumper options. One, JP1, selects SPI operation, which is usable if the user also does not use a jumper at JP23 on the motherboard and provides host SPI connectivity at J103. The other jumper, JP2, enables the operation of the EEPROM chip, which is on the daughter card. There is an EEPROM chip on the motherboard, which is only used with the TSSOP daughter card.

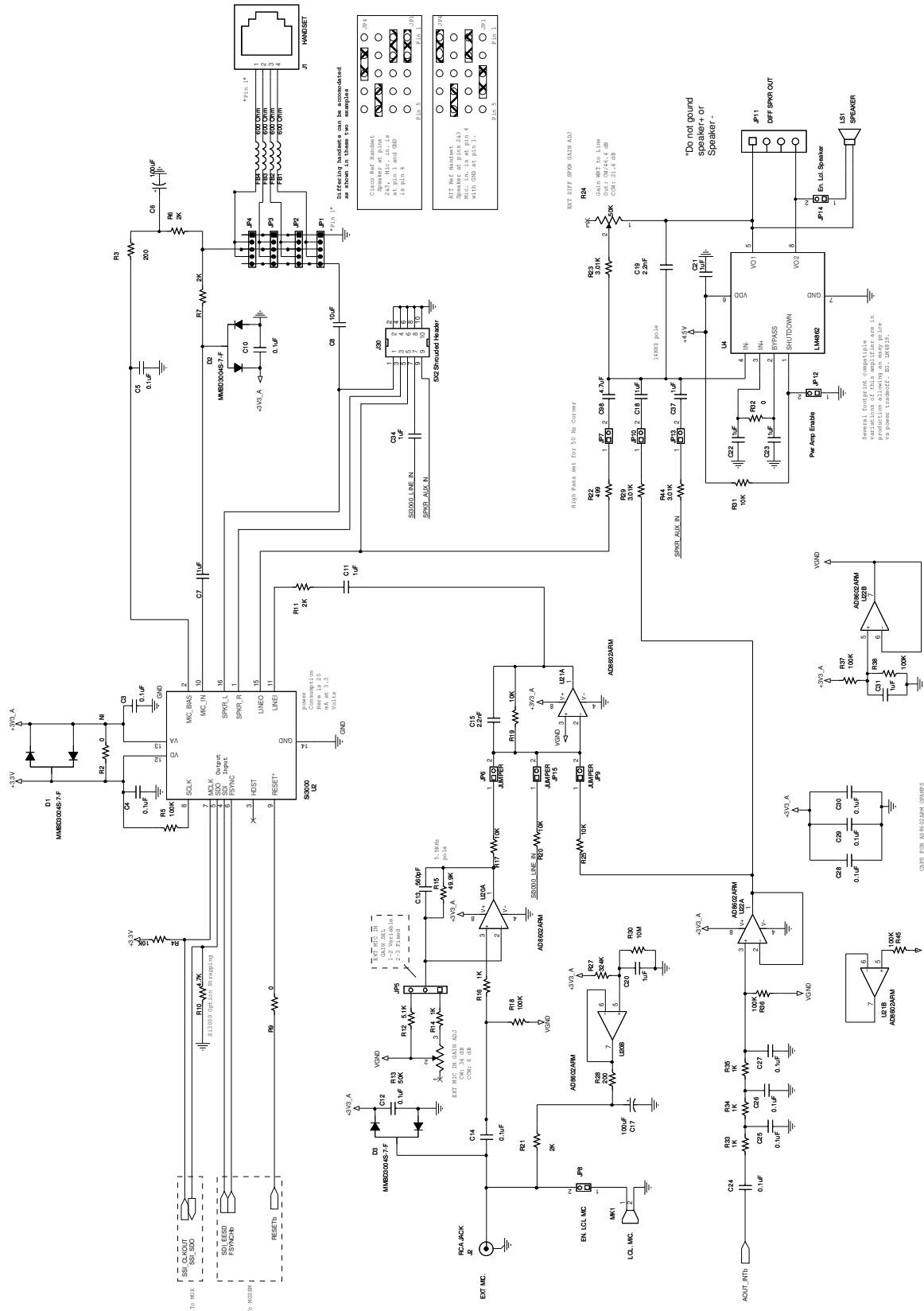

Figure 26. Motherboard Sound Processing Circuits

Si2494/39/38/37/36/35/29/19/18/17FT18-EVB

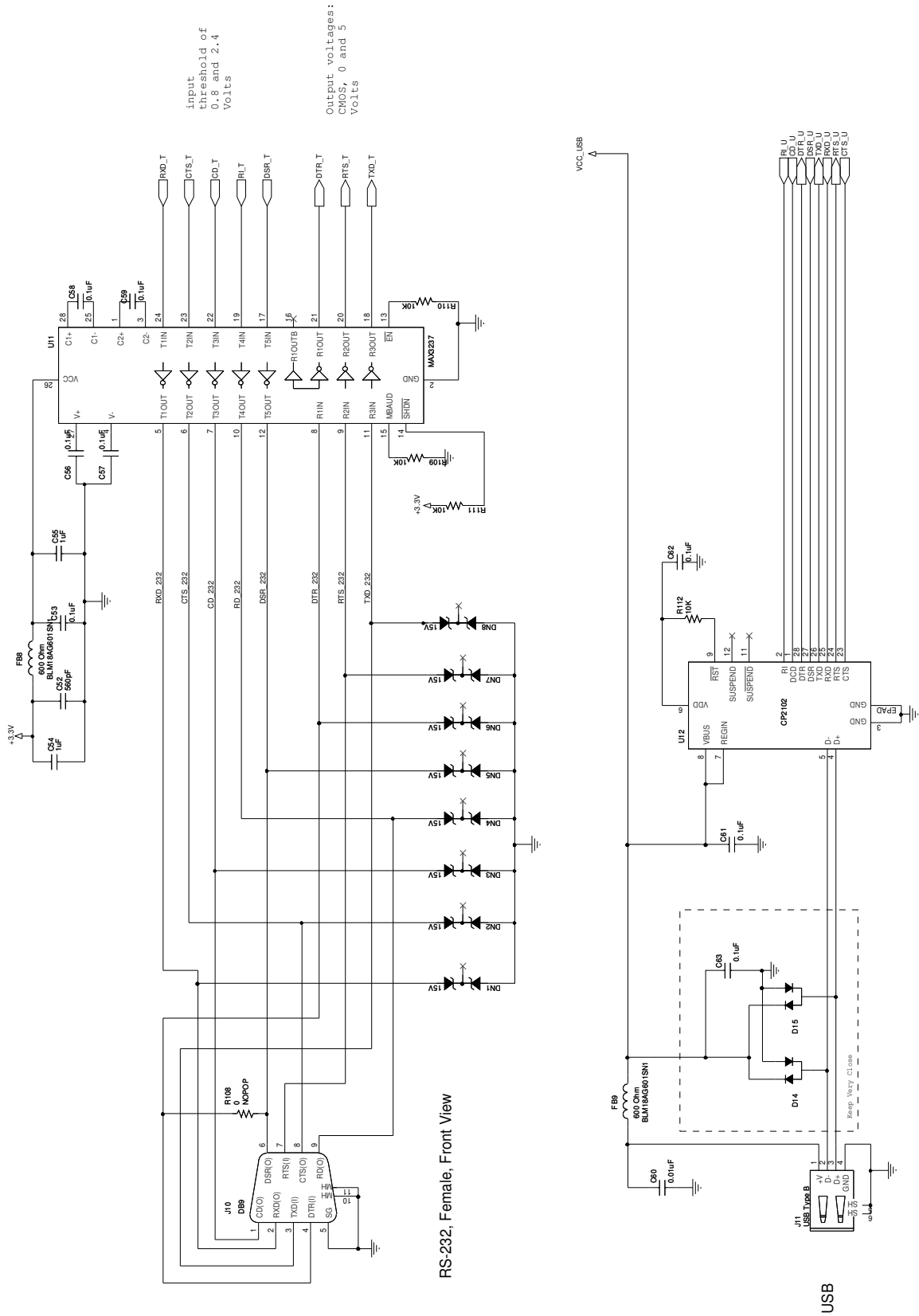

Figure 27. Motherboard Host I/O

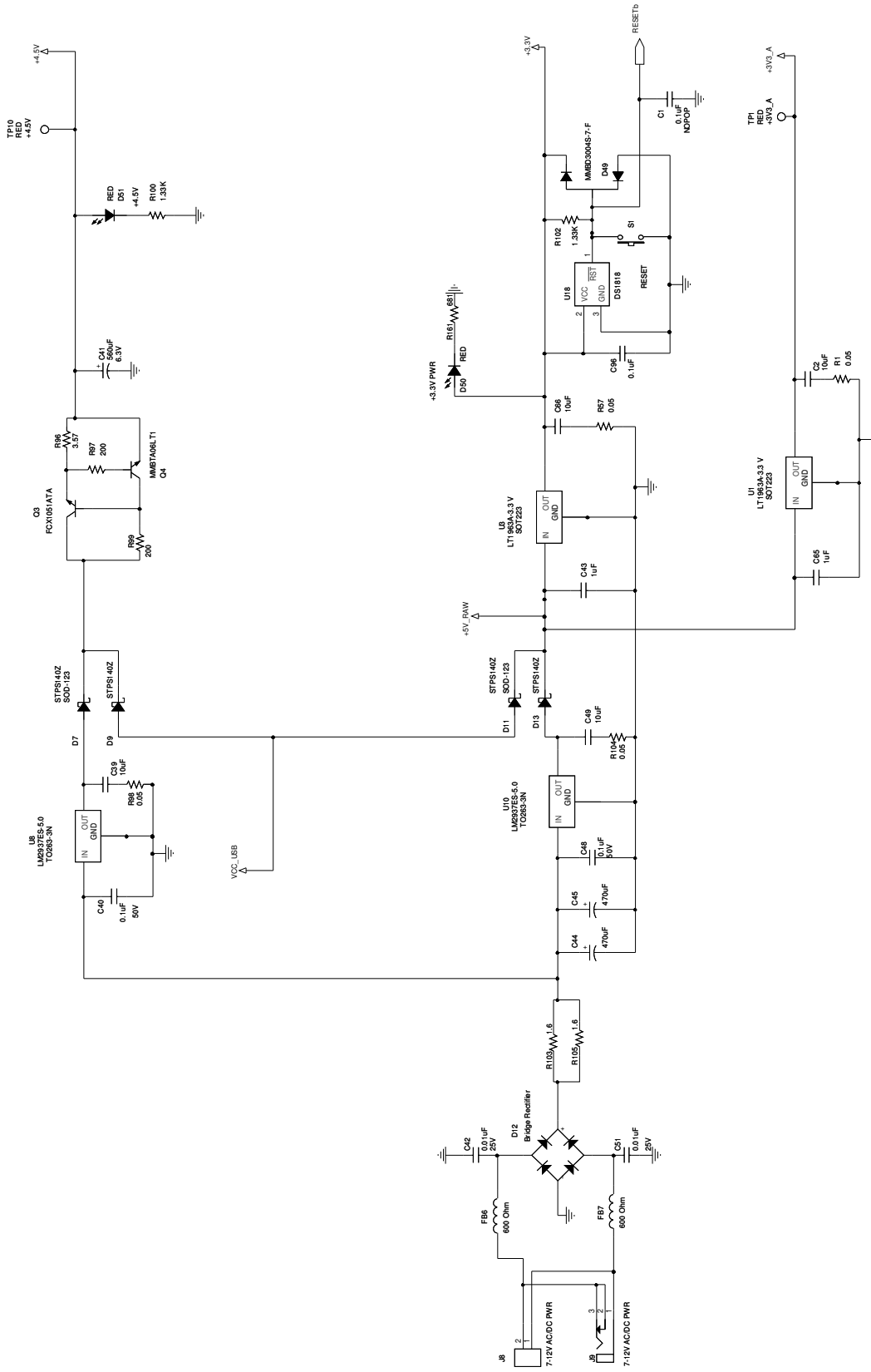
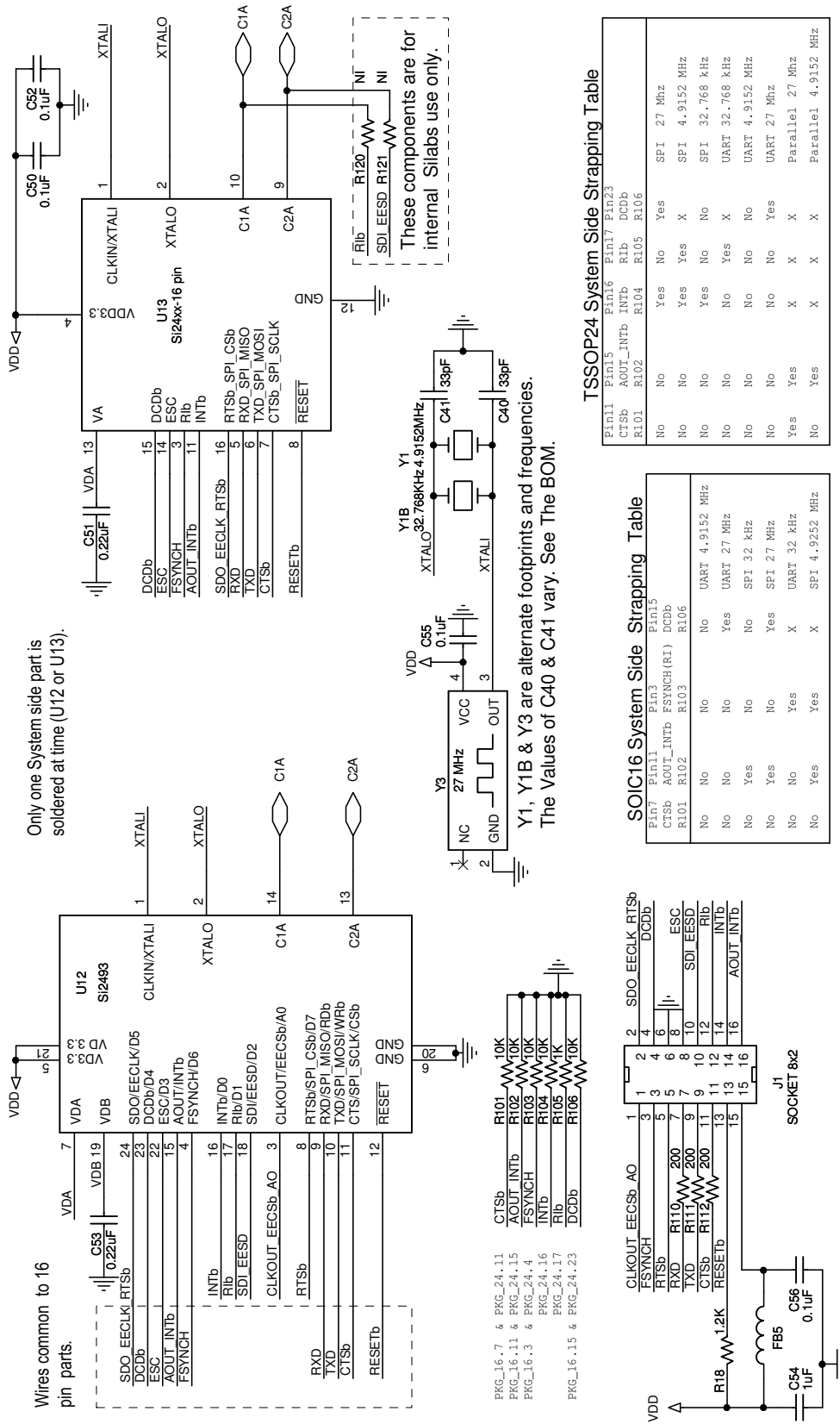

Figure 28. Motherboard Power Supply and Reset



TSSOP24 System Side Strapping Table

Pin15	Pin16	Pin17	Pin23	DCDbb	R101	R102	R104	R105	R106
CTsb	ACOUT_INTb	INTb	INTb	DCDbb	No	No	No	No	No
Yes	Yes	Yes	Yes	Yes	No	No	No	No	No
No	No	No	No	No	Yes	Yes	Yes	Yes	Yes
No	No	No	No	No	No	No	No	No	No
No	No	No	No	No	No	No	No	No	No
No	No	No	No	No	No	No	No	No	No
Yes	Yes	Yes	Yes	Yes	X	X	X	X	X
No	No	No	No	No	No	No	No	No	No

SOIC16 System Side Strapping Table

Pin7	Pin11	Pin3	Pin5	DCDbb	R101	R102	R103	R106
CTsb	ACOUT_INTb	FSYNCH(RT)	DCDbb	DCDbb	No	No	No	No
No	No	No	No	No	No	No	No	No
No	No	No	No	Yes	Yes	Yes	Yes	Yes
No	No	No	No	No	No	No	No	No
No	No	No	No	No	No	No	No	No
No	No	No	No	Yes	Yes	Yes	Yes	Yes
No	No	Yes	Yes	X	X	X	X	X
No	No	Yes	Yes	X	X	X	X	X
No	No	Yes	Yes	X	X	X	X	X

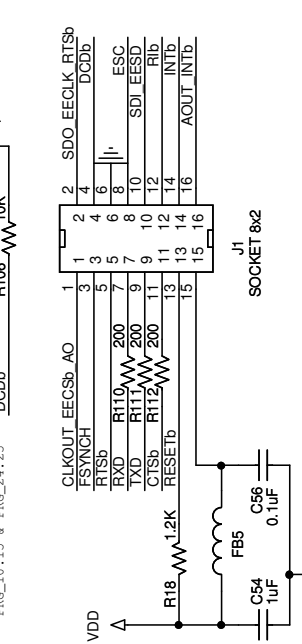
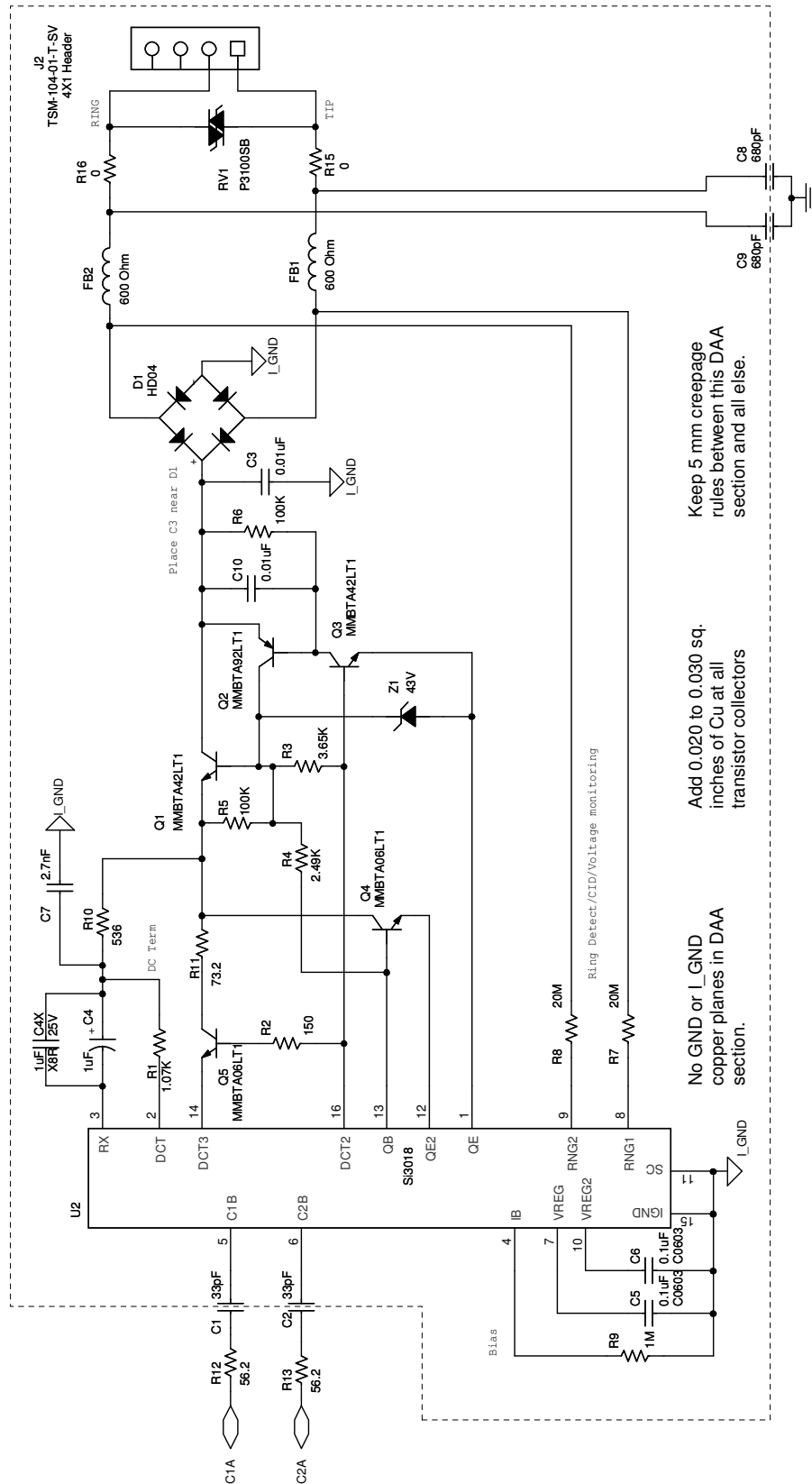

Figure 29. Daughter Card (Si24xx2G-DC Rev 2.0) System Side



Keep 5 mm creepage rules between this DAA section and all else.

Add 0.020 to 0.030 sq. inches of Cu at all transistor collectors

No GND or L_GND copper planes in DAA section.

Figure 30. Daughter Card (Si24xx2G-DC Rev 2.0) Line Side

Si2494/39/38/37/36/35/29/19/18/17FT18-EVB

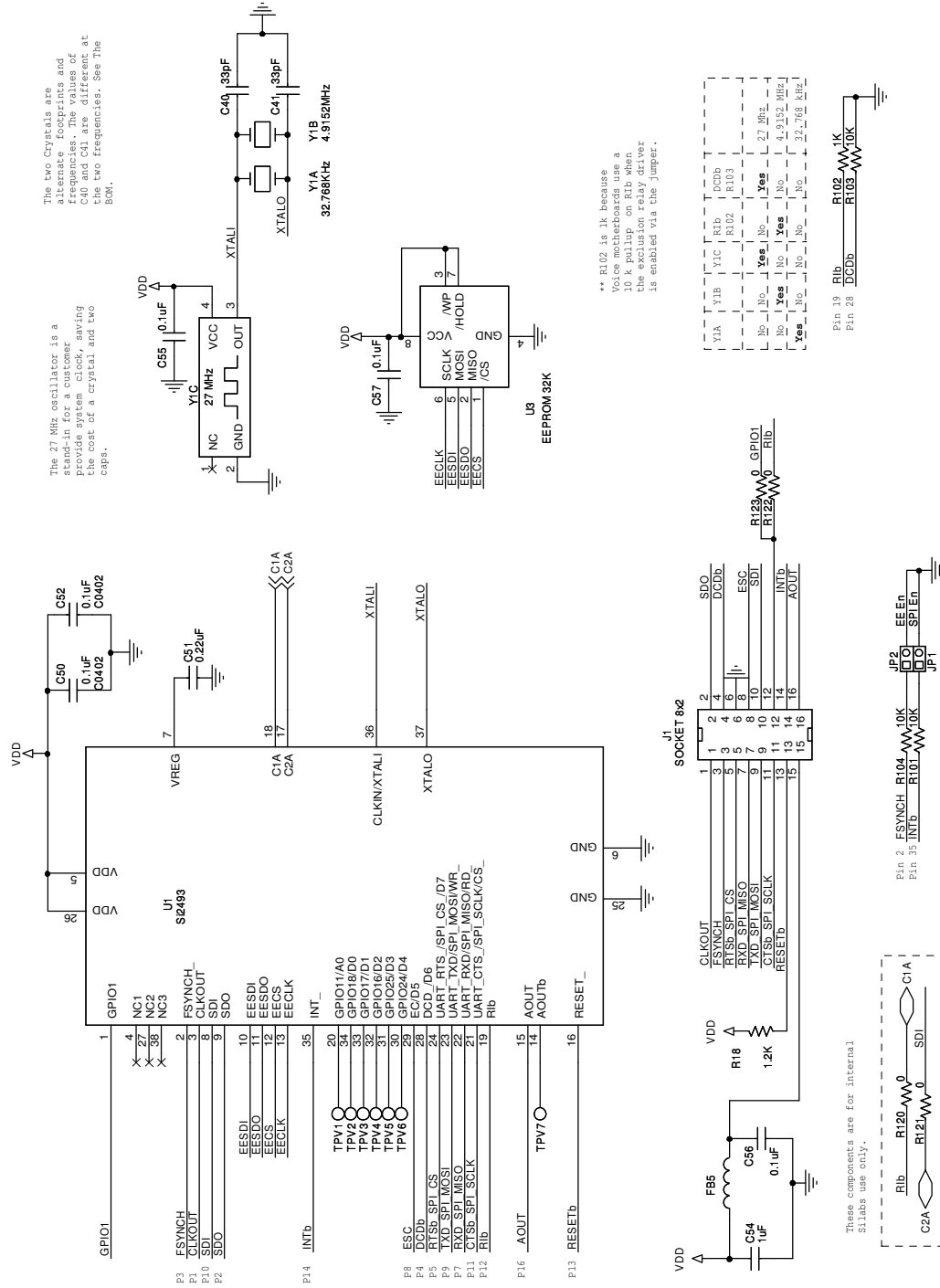

Figure 31. QFN Daughter Card (Si24xx2G-QFN38-DC Rev 1.0) System Side



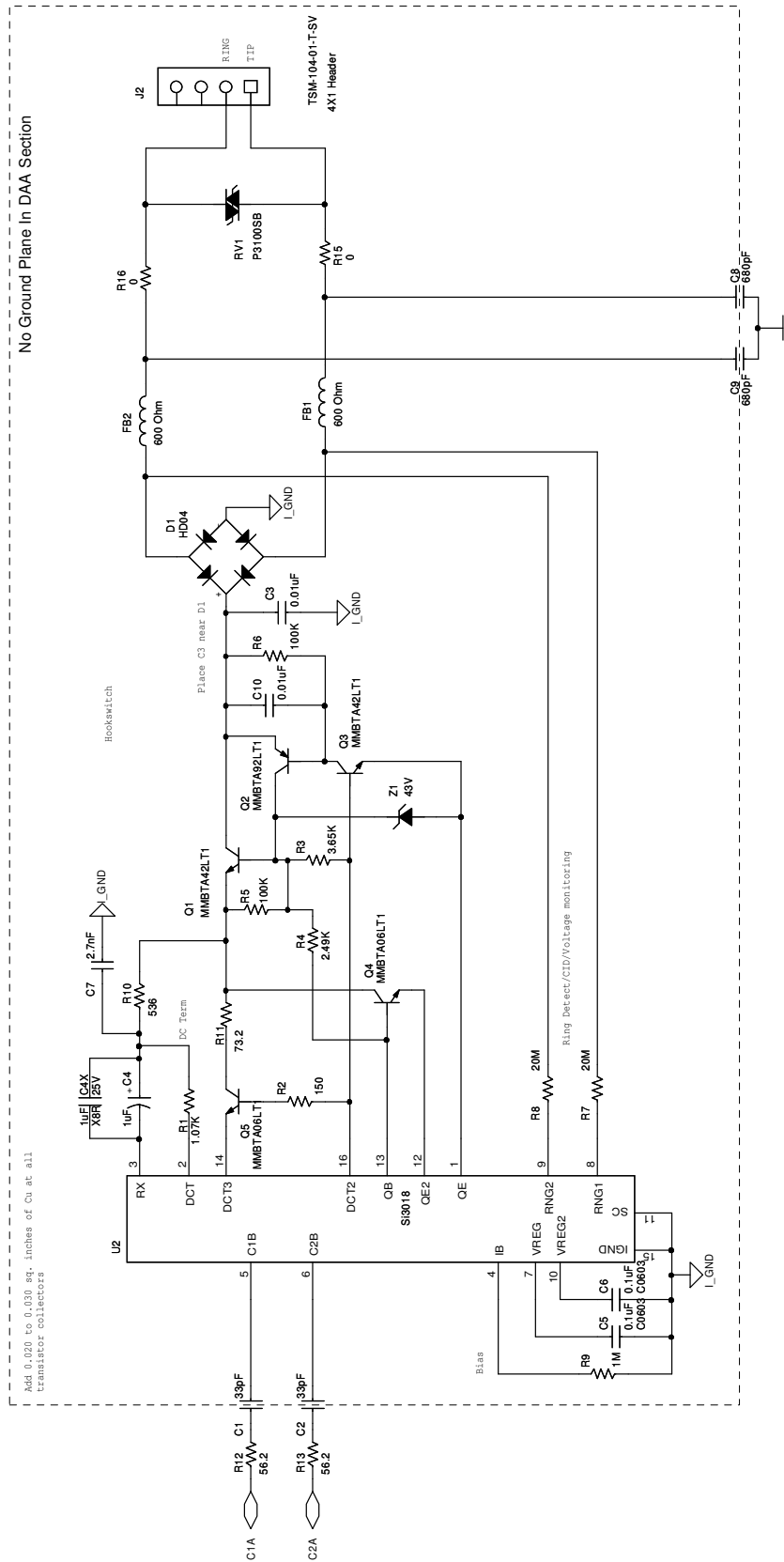

Figure 32. Daughter Card (Si24xx2G-QFN38-DC Rev 1.0) Line Side

6. Motherboard and Daughter Card PCB Layouts

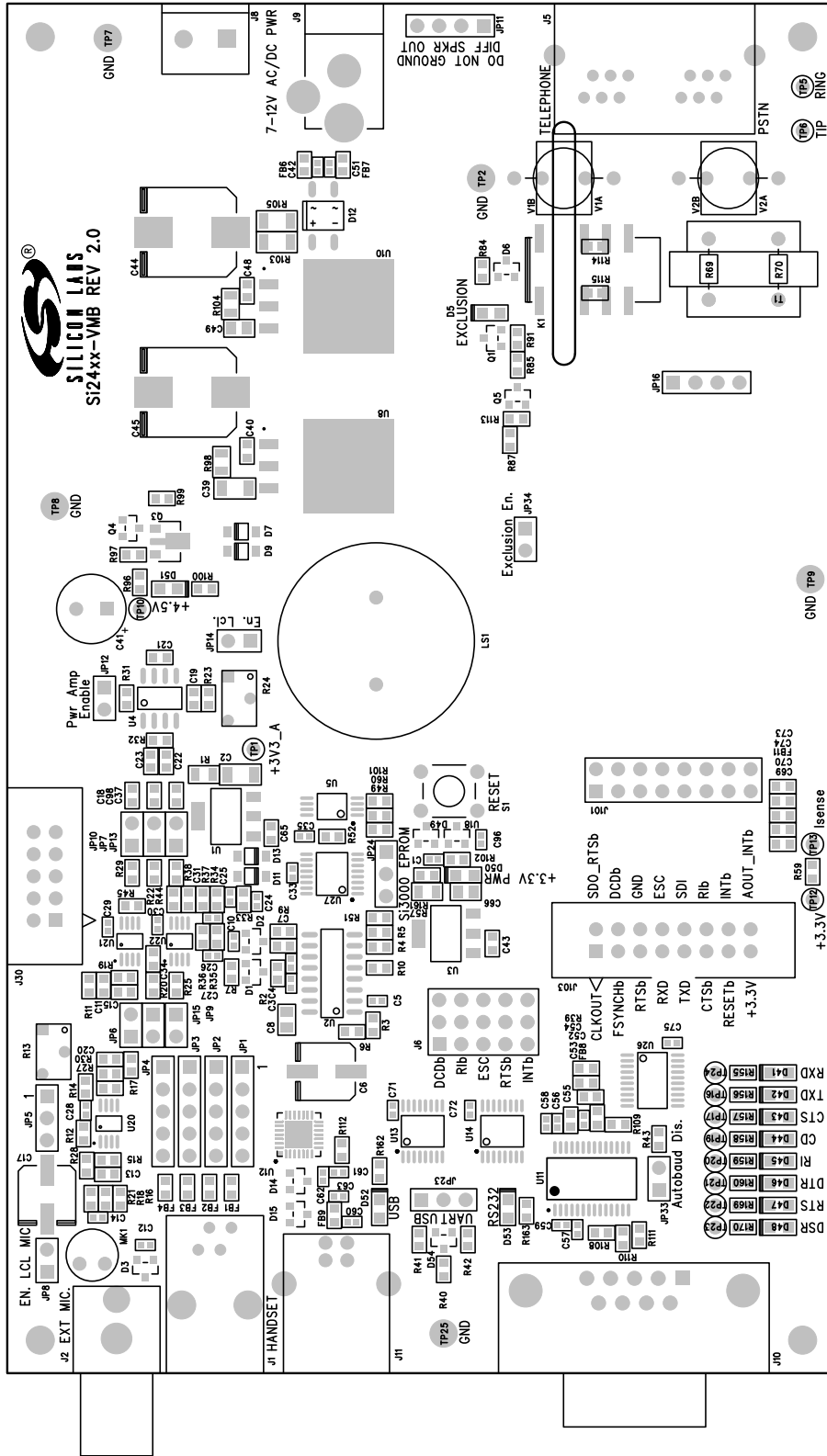

Figure 33. Motherboard Primary Side Component and Silkscreen View

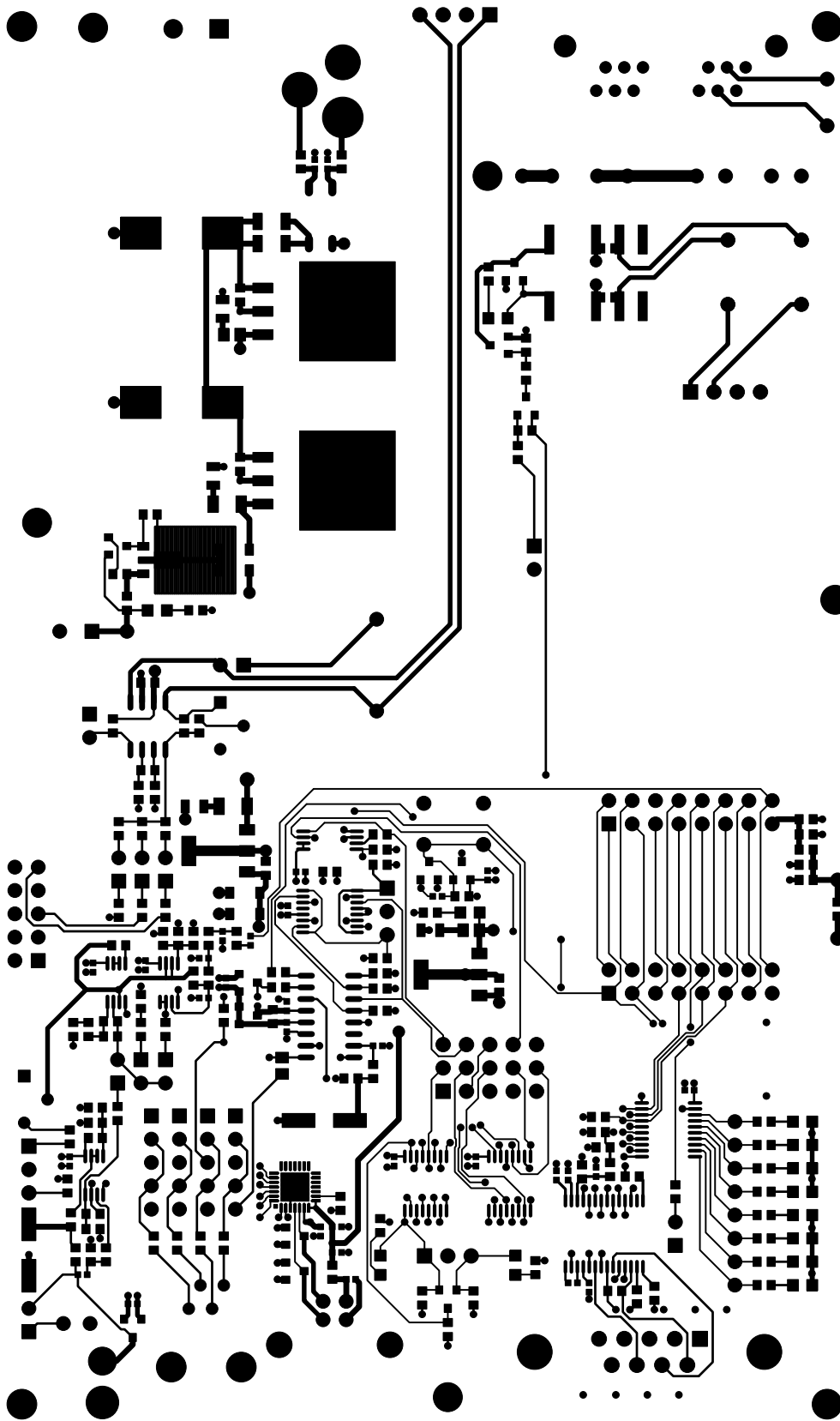

Figure 35. Motherboard Primary Side Signal Layer

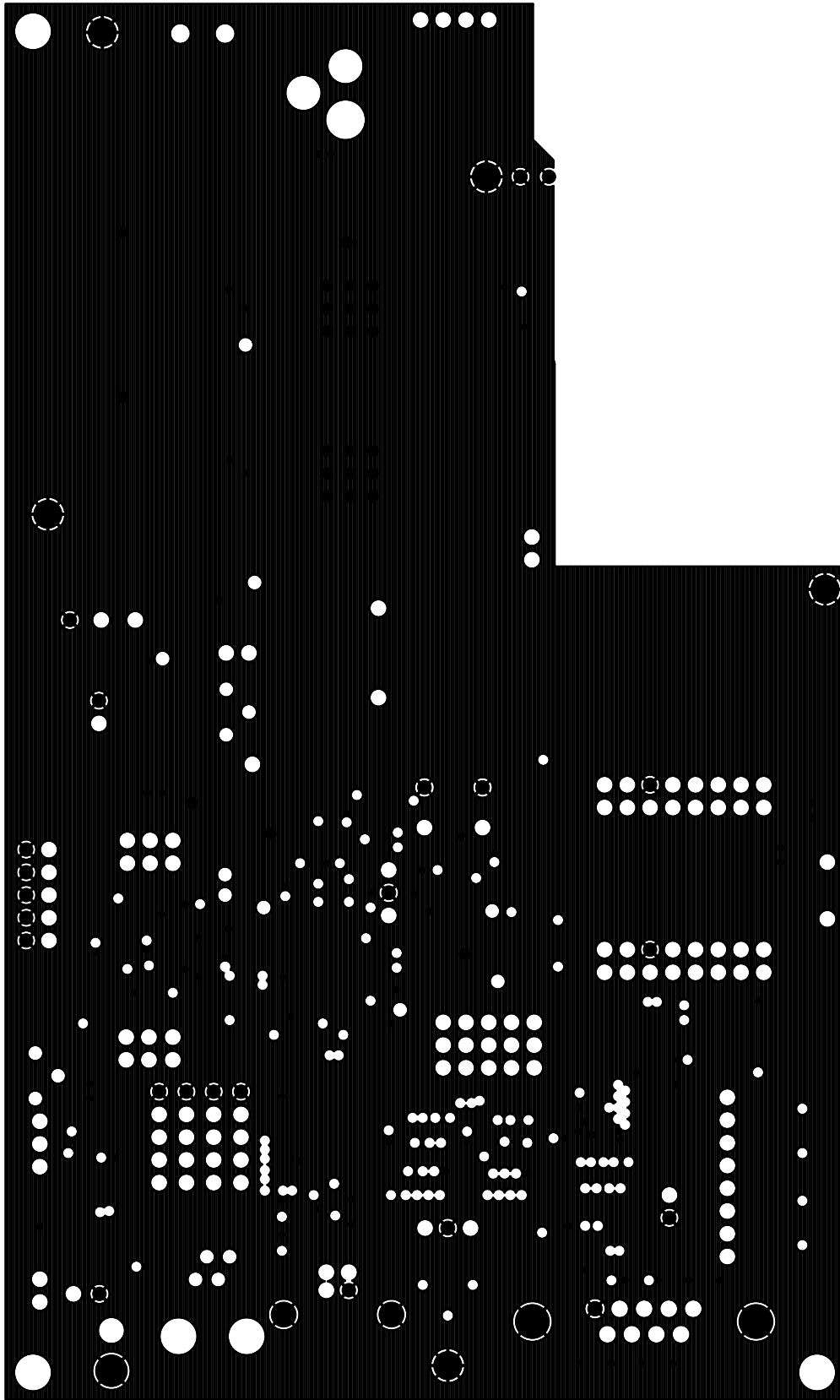

Figure 36. Motherboard Layer 2 Ground Plane

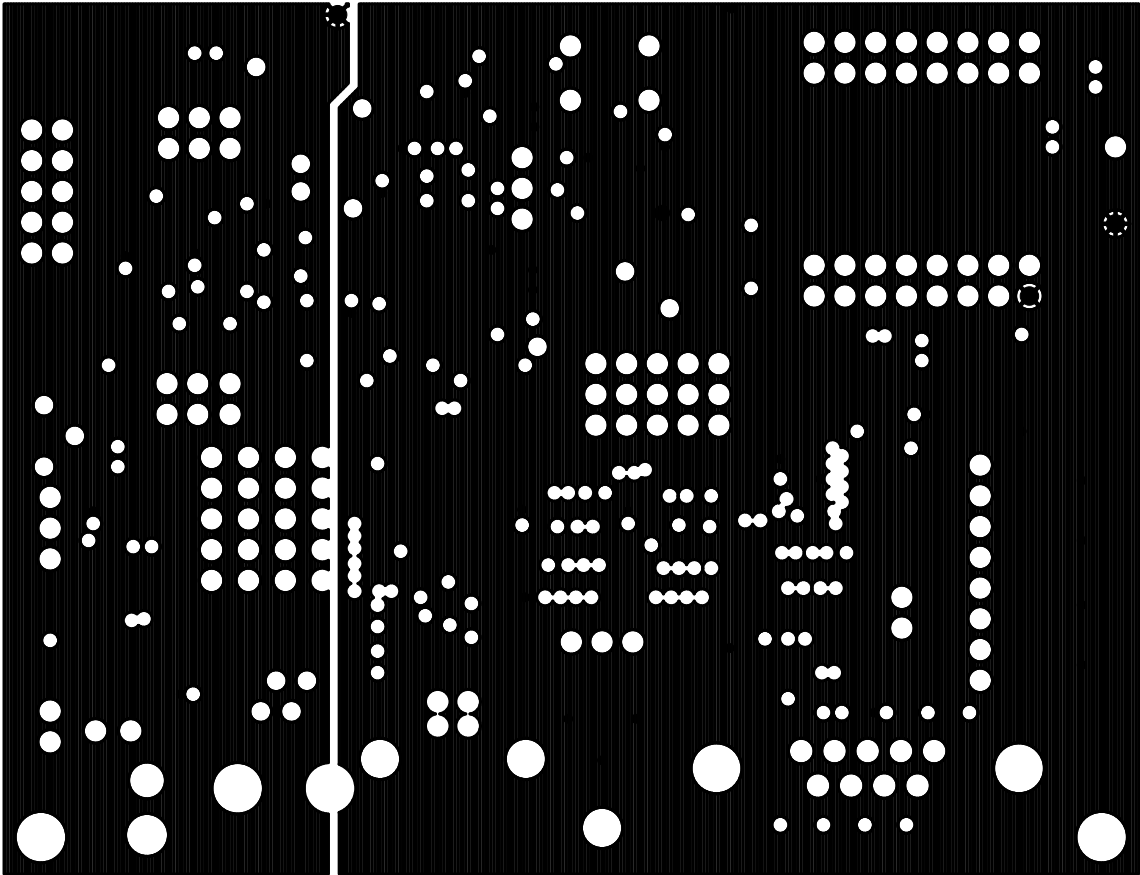

Figure 37. Motherboard Layer 3 Power Plane

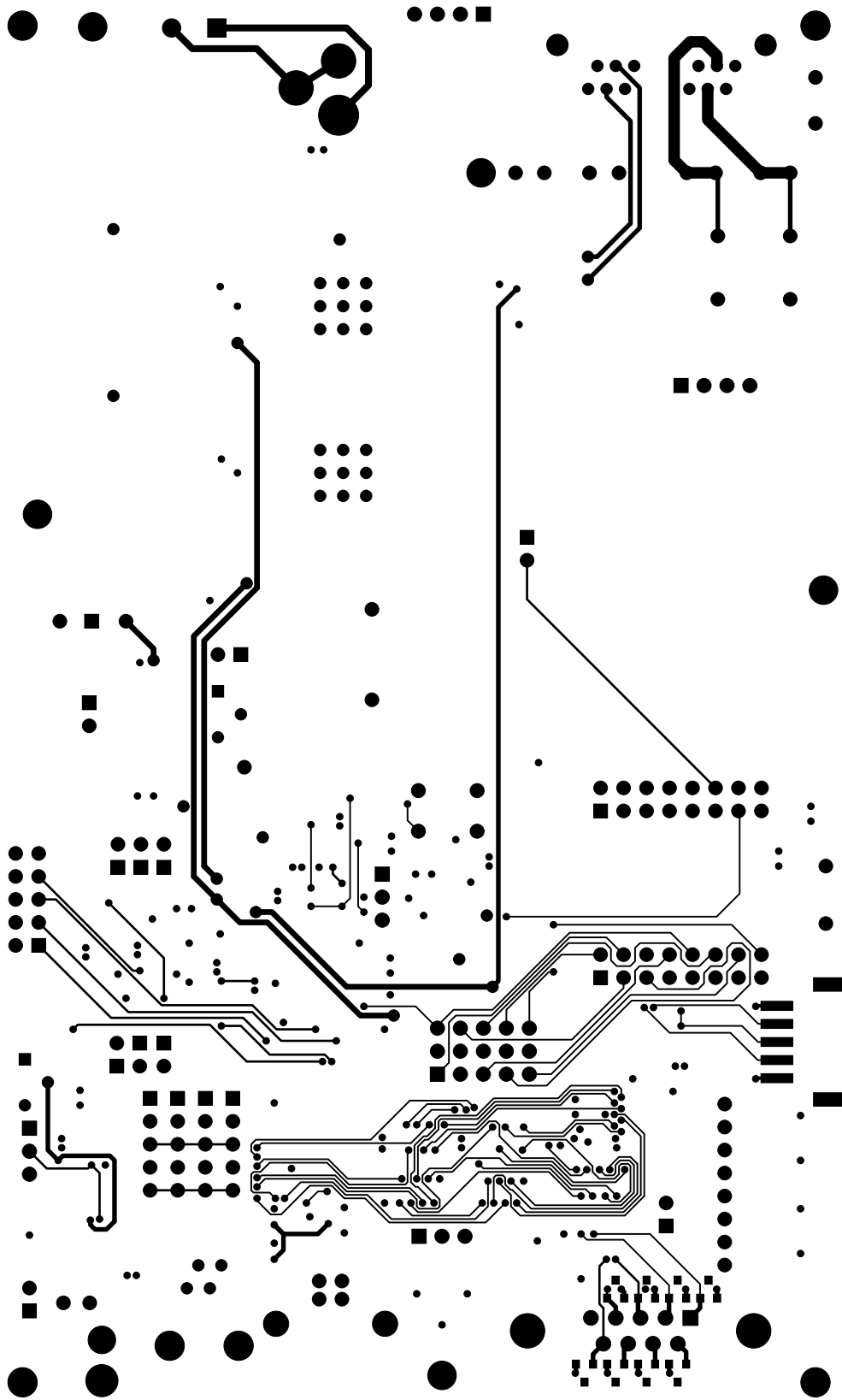

Figure 38. Motherboard Secondary Side, Signal Layer

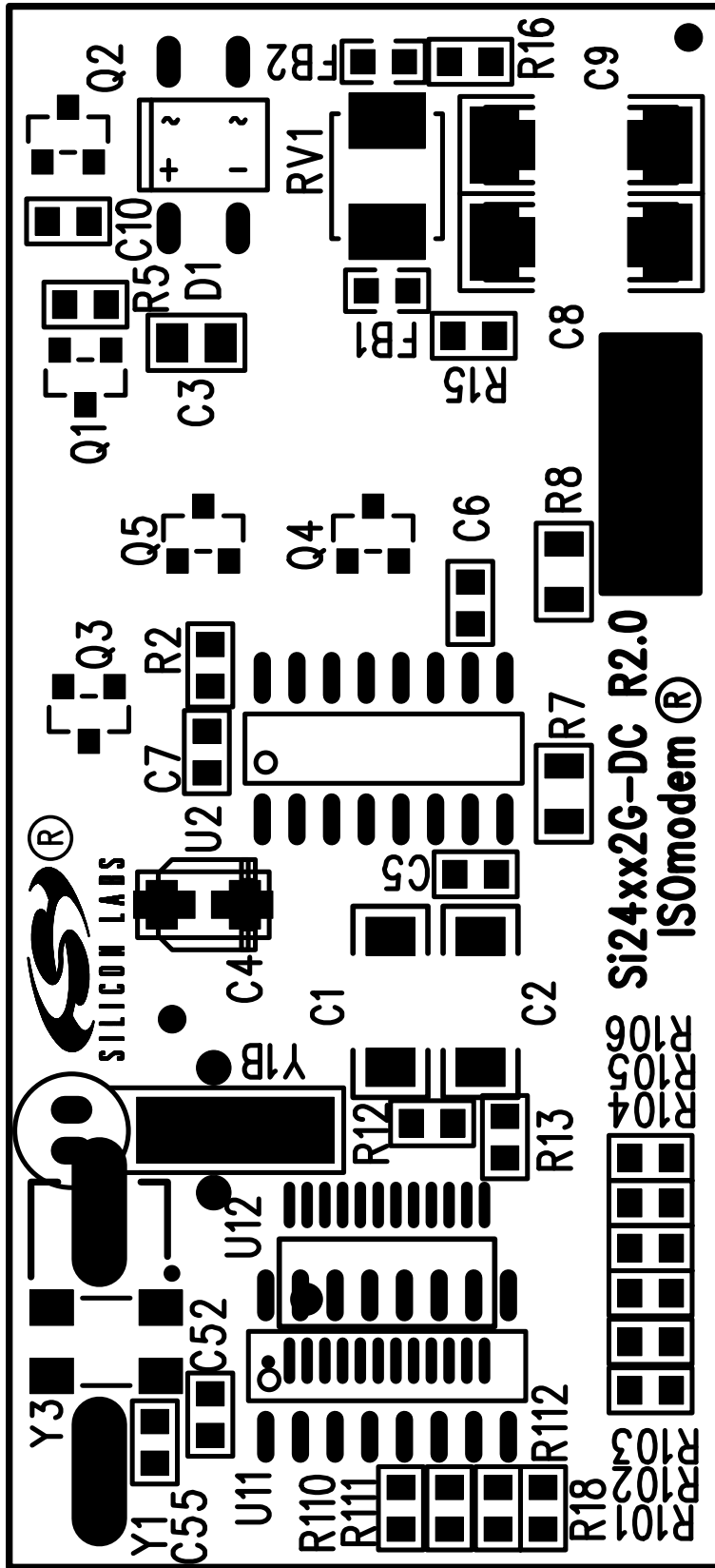

Figure 39. Daughter Card Primary Side, Component and Silkscreen

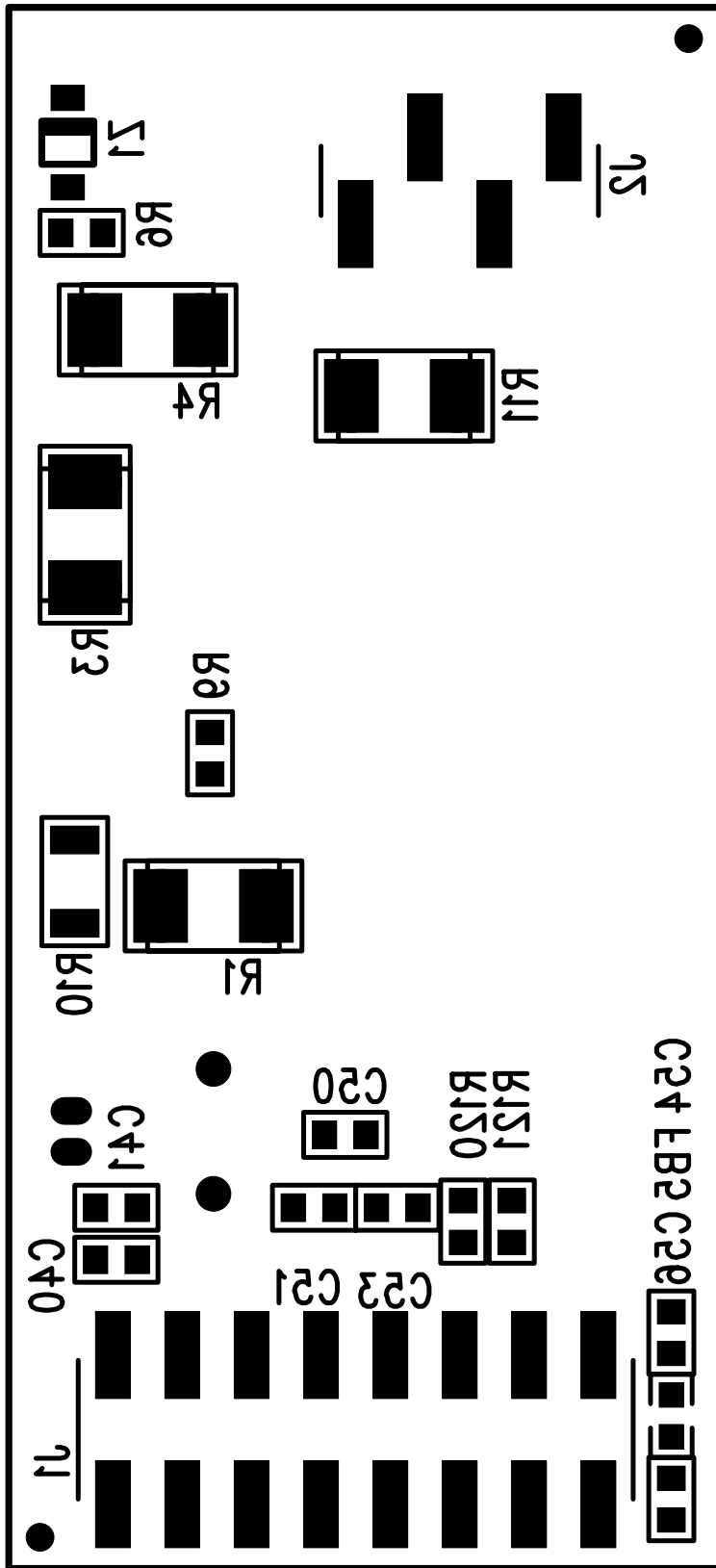

Figure 40. Daughter Card Secondary Side, Component and Silkscreen

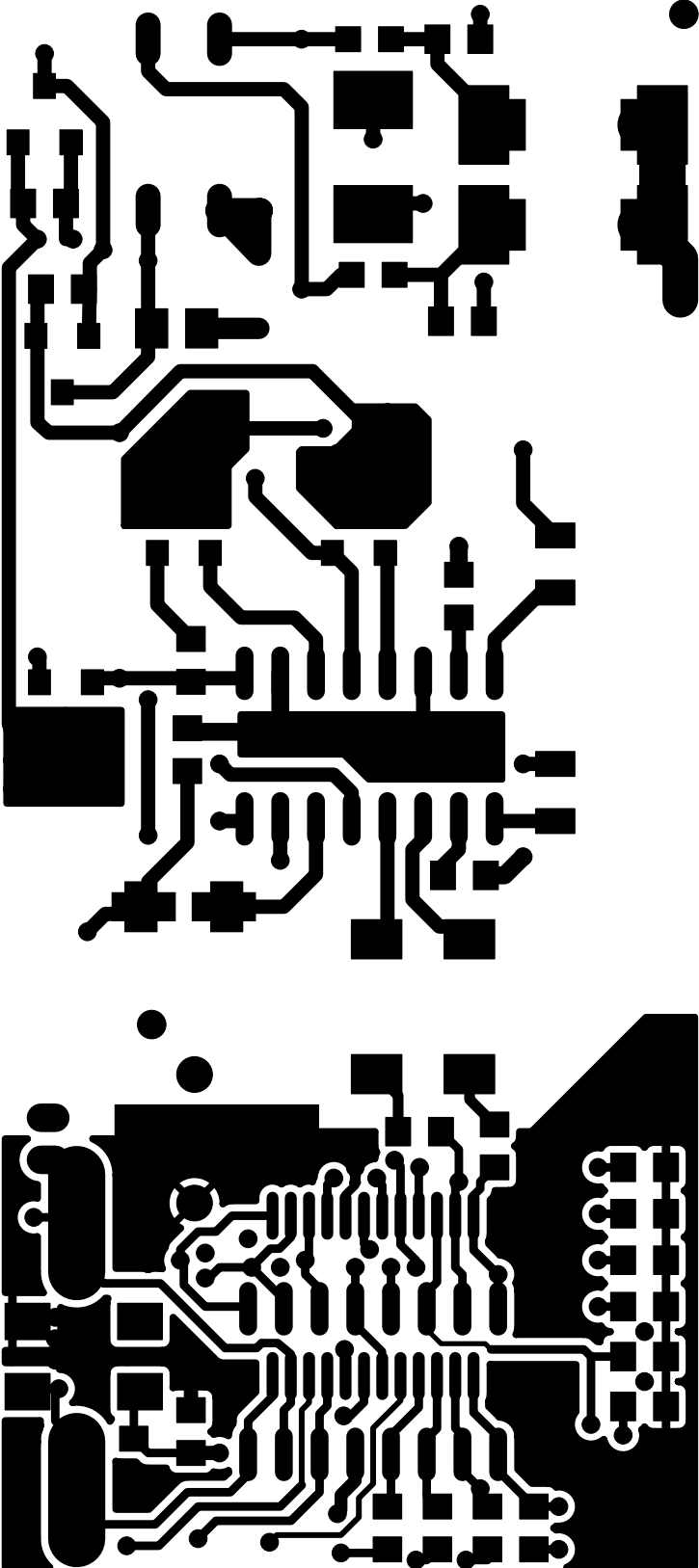

Figure 41. Daughter Card Primary Side

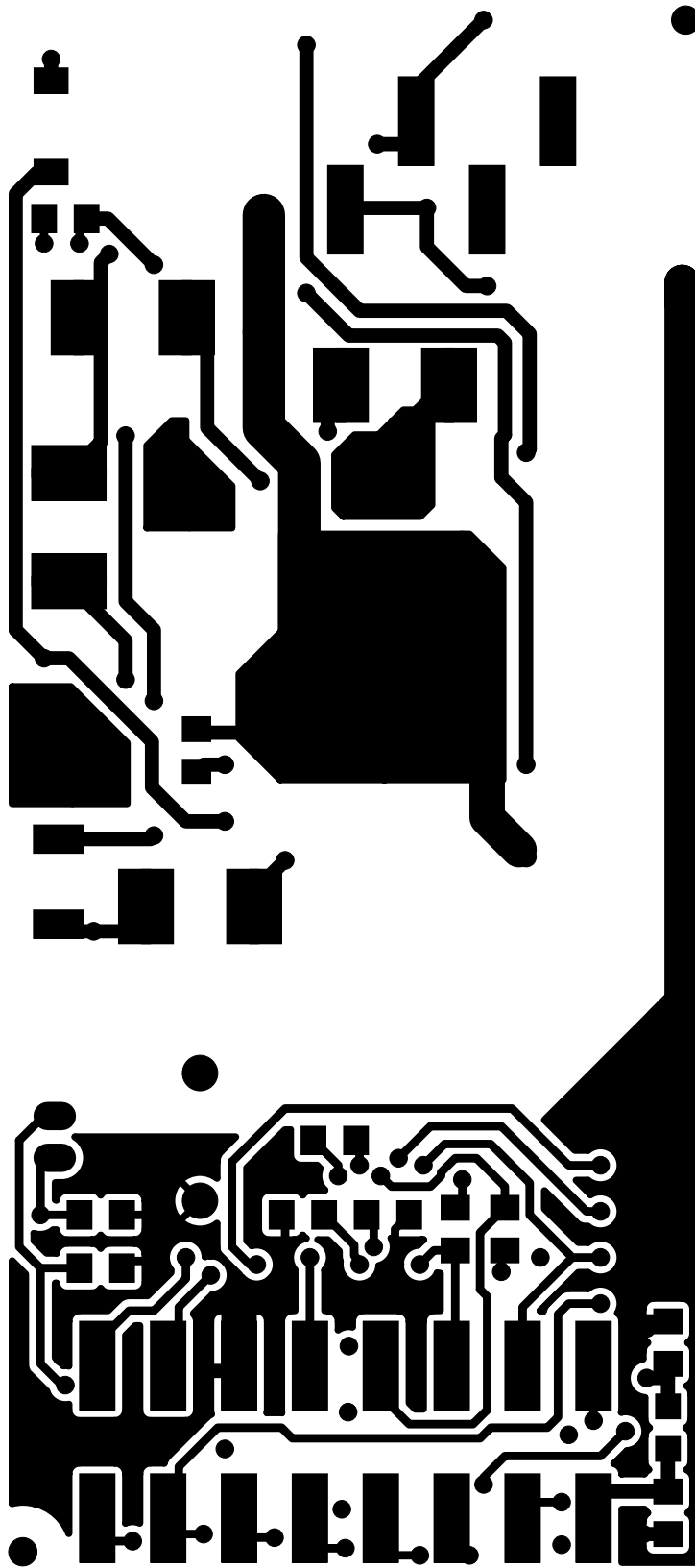

Figure 42. Daughter Card Secondary Side

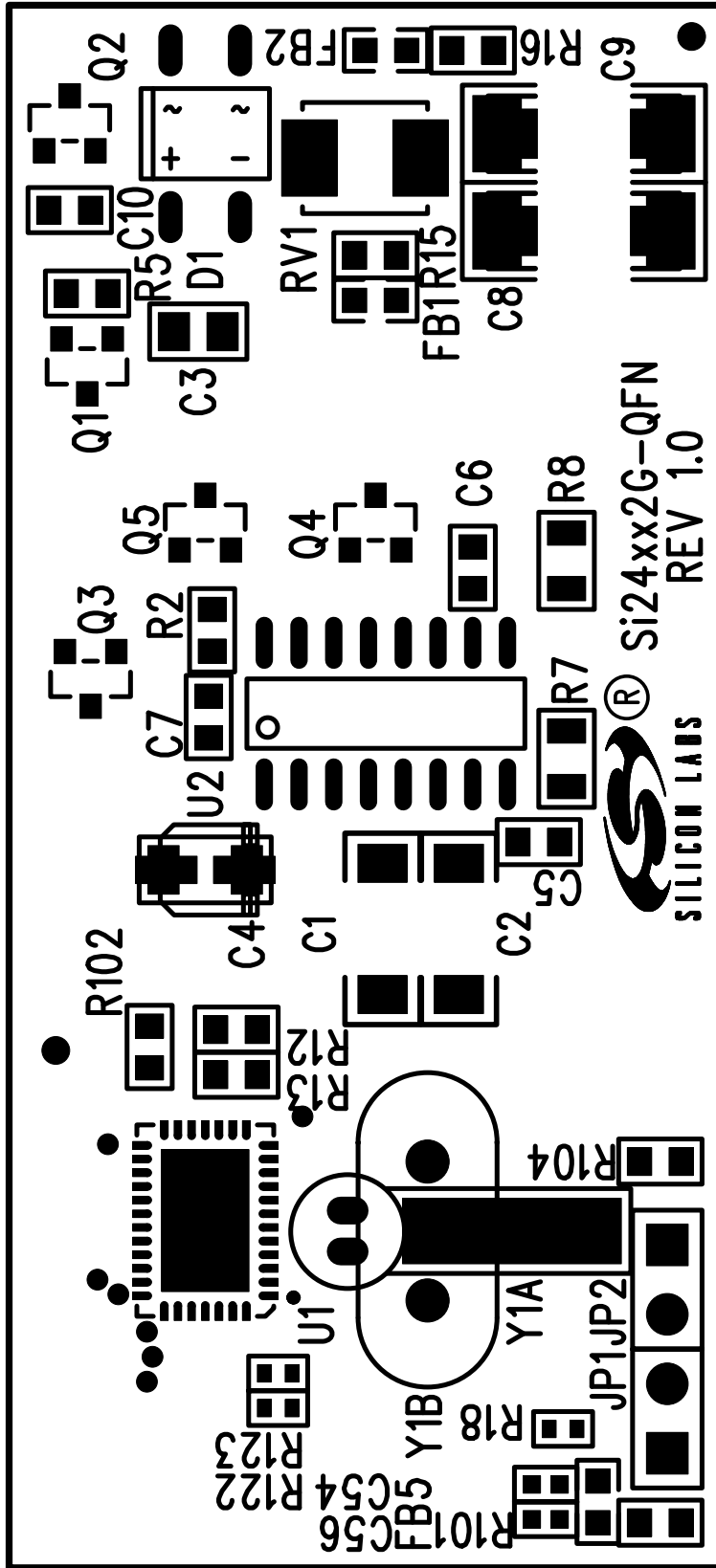

Figure 43. QFN Daughter Card Primary Side, Component and Silkscreen

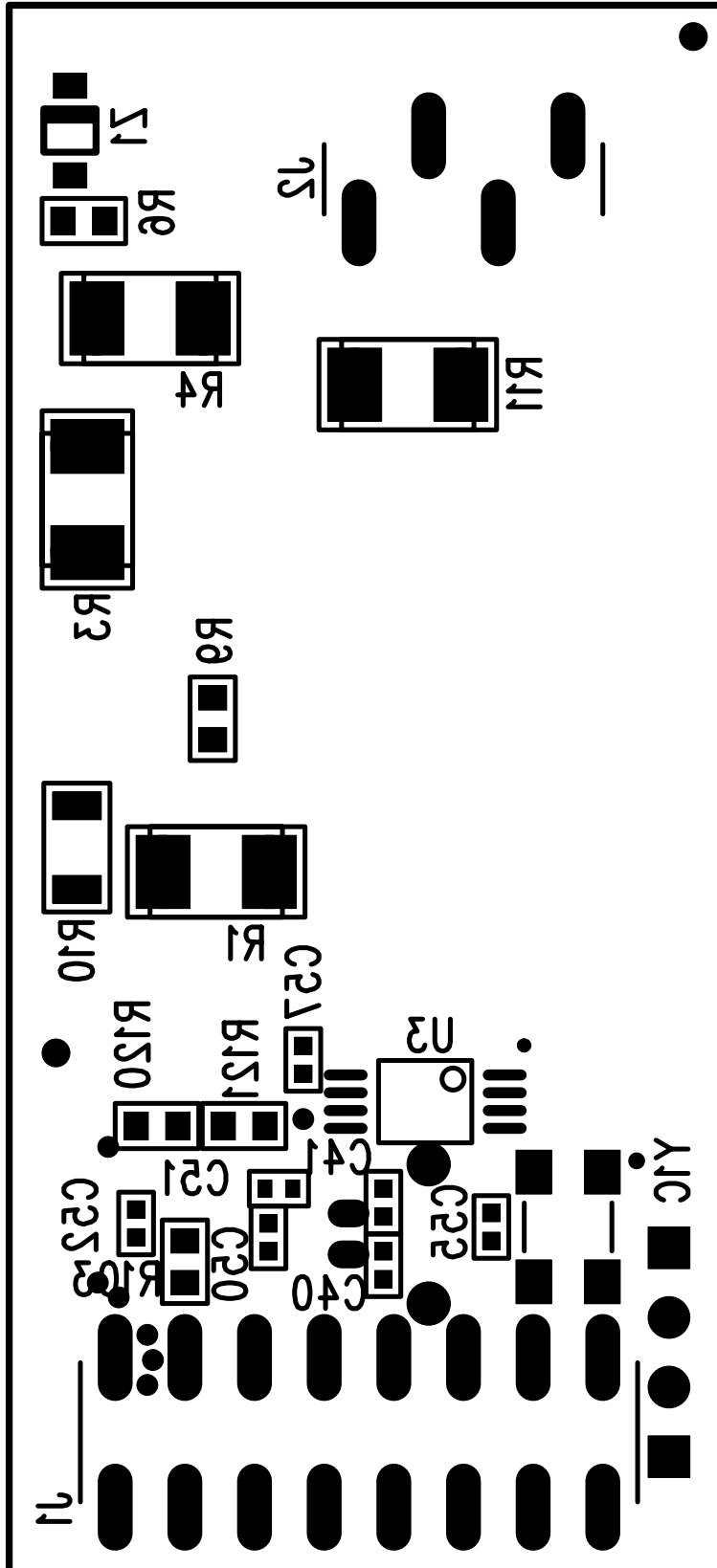

Figure 44. QFN Daughter Card Secondary Side, Component and Silkscreen

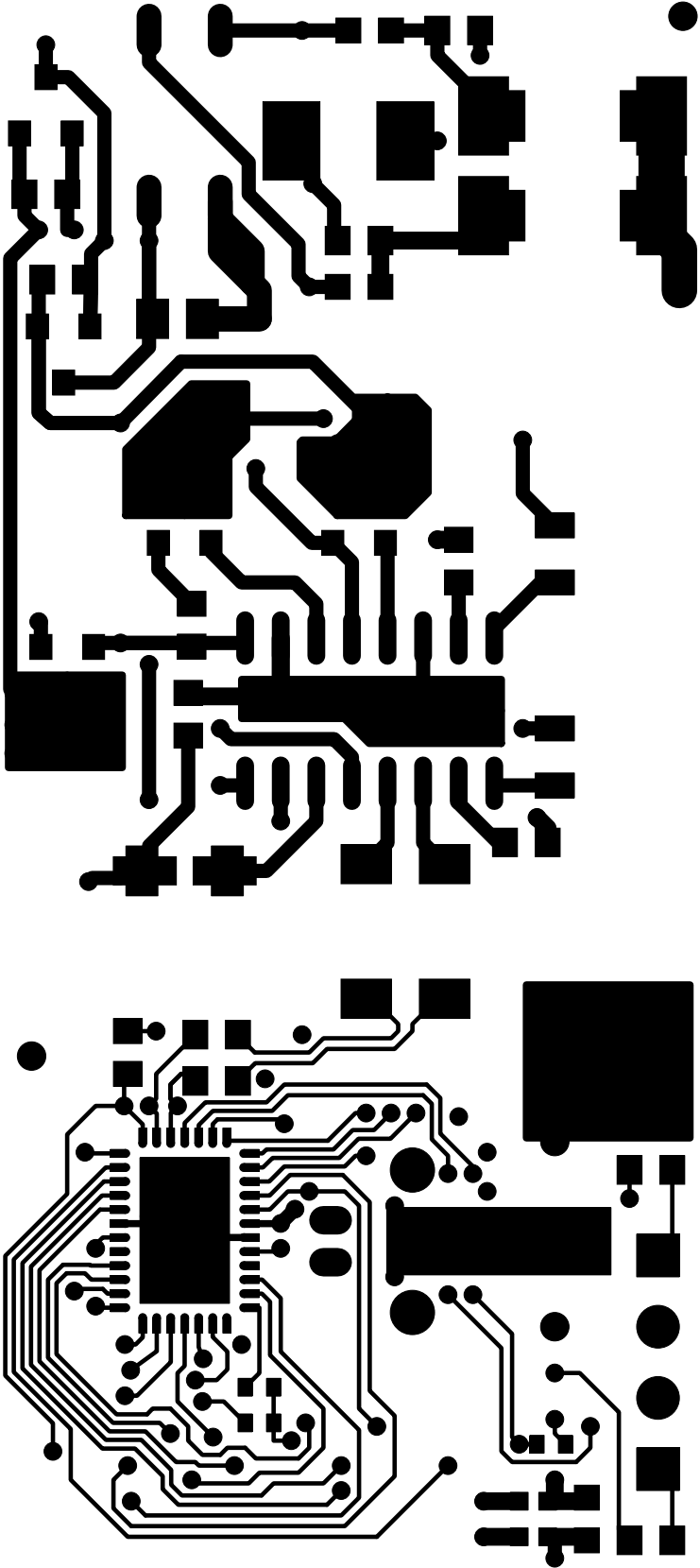

Figure 45. QFN Daughter Card Primary Side

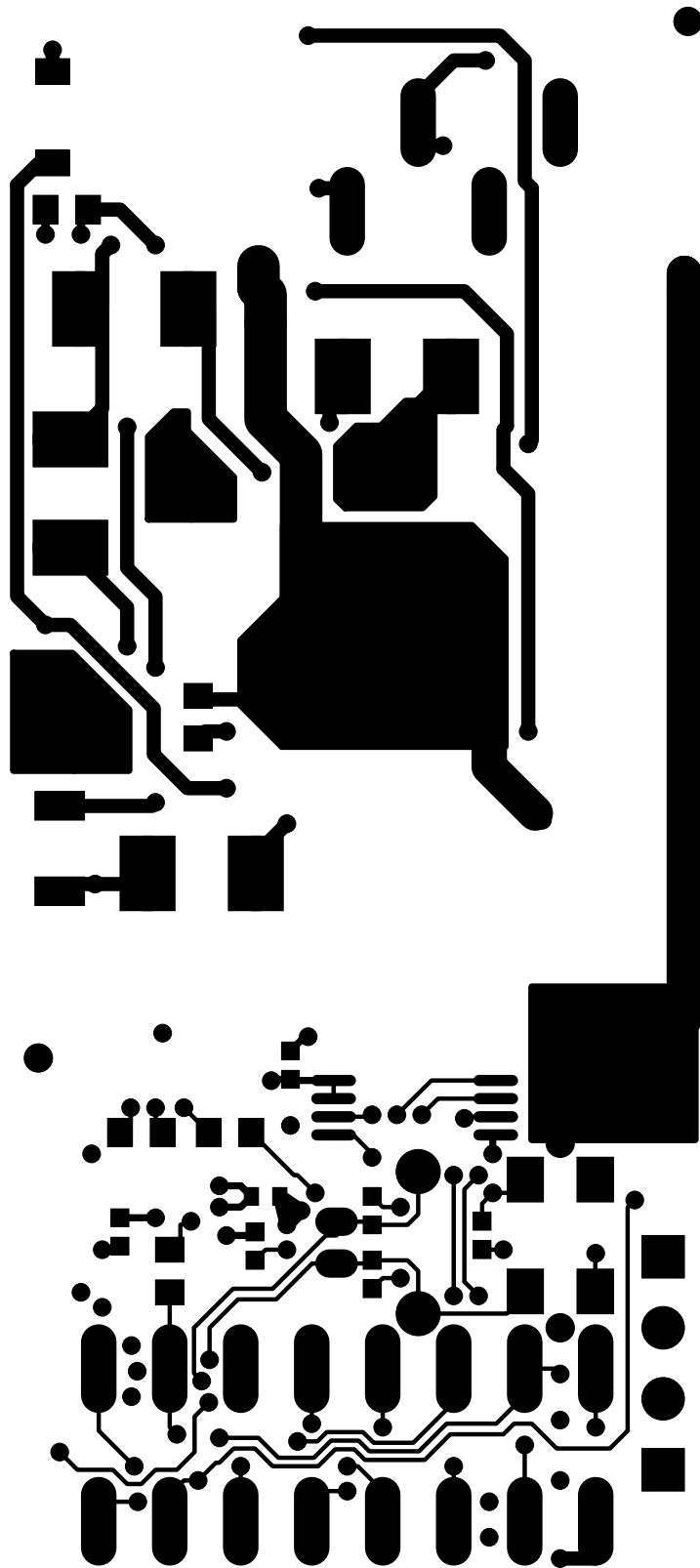

Figure 46. QFN Daughter Card Secondary Side

Si2494/39/38/37/36/35/29/19/18/17FT18-EVB

7. Bill of Materials

The following sections contain the bills of materials for the motherboard and daughter card.

7.1. Motherboard Bill of Materials

Table 7. MotherBoard Bill of Materials

Item	NI	Qty	Ref	Value	Rating	Voltage	Tol	Type	PCB Footprint	Mfr Part Number	Mfr
48	NI	3	R2, R114, R115	0 Ω	1A			ThickFilm	R0603	CR0603-16W-000	Venkel
1	NOPOP	1	C1	0.1 μF		10V	±20%	X7R	C0402	C0402X7R100-104M	Venkel
33	NOPOP	1	J7	2 mm, RT ANG				SHROUDED	CONN1X5-S5B-PH-SM4-TB	S5B-PH-SM4-TB	JST
63	NOPOP	6	R39, R49, R51	10 kΩ	1/10W		±1%	ThickFilm	R0603	CR0603-10W-1002F	Venkel
71	NOPOP	1	R108	0 Ω	1A			ThickFilm	R0603	CR0603-16W-000	Venkel
77	NOPOP	1	T1	3.3 mH				TelCom	IND-CMC-7X8	750311349	Würth/Midcom
90	NOPOP	1	V1A	1000 V		1000V		GDT	GDT-RA-C6-Y	RA-102M-C6-Y	OKAYA
91	NOPOP	1	V1B	800 V		800V		GDT	GDT-450-6X8MM	GTCA28-801L-P05	Tyco
92	NOPOP	1	V2A	350 V		350V		GDT	GDT-RA-C6-Y	RA-351M-C6-Y	OKAYA
93	NOPOP	1	V2B	350 V		350V		GDT	GDT-450-6X8MM	GTCA28-351L-P05	Tyco
2		2	C2 C39	10 μF		10V	±20%	X7R	C1206	C1206X7R100-106M	Venkel
3		27	C3, C4, C5, C10, C12, C14, C24, C25, C26, C27, C28, C29, C30, C33, C35, C53, C56, C57, C58, C59, C61, C62, C63, C71, C72, C75, C96	0.1 μF		10V	±20%	X7R	C0402	C0402X7R100-104M	Venkel
4		2	C6, C17	100 μF		16V	±20%	Alum_Elec	C6.6X6.6MM	EEEFK1C101P	Panasonic
5		16	C7, C11, C18, C20, C21, C22, C23, C31, C34, C37, C43, C54, C55, C65, C69, C74	1 μF		10V	±10%	X7R	C0603	C0603X7R100-105K	Venkel
6		3	C8, C49, C66	10 μF		16V	±10%	X5R	C0805	C0805X5R160-106K	Venkel
7		4	C13, C52, C70 C73	560 pF		16V	±10%	X7R	C0603	C0603X7R160-561K	Venkel
8		2	C15, C19	2.2 nF		16V	±10%	X7R	C0603	C0603X7R160-222K	Venkel
9		2	C40, C48	0.1 μF		50V	±10%	X7R	C0603	C0603X7R500-104K	Venkel

Si2494/39/38/37/36/35/29/19/18/17FT18-EVB

Table 7. MotherBoard Bill of Materials (Continued)

Item	NI	Qty	Ref	Value	Rating	Voltage	Tol	Type	PCB Footprint	Mfr Part Number	Mfr
10		1	C41	560 μ F		6.3V	\pm 20%	Alum_Elec	C3.5X8MM-RAD	EEUFM0J561	Panasonic
11		3	C42, C51, C60	0.01 μ F		25 V	\pm 10%	X7R	C0402	C0402X7R250-103K	Venkel
12		2	C44, C45	470 μ F		25 V	\pm 20%	Alum_Elec	C10.3X10.3MM	EMVE250ADA471MJ A0G	United Chemicon
13		1	C98	4.7 μ F		6.3 V	\pm 10%	X5R	C0603	C0603X5R6R3-475K	Venkel
14		8	DN1, DN2, DN3, DN4, DN5, DN6, DN7, DN8,	15 V	225 mW	15 V		Zener, Dual	SOT23-AAK	MMBZ15VDLT1G	On Semi
15		7	D1, D2, D3, D6, D14, D15, D49	MMBD3004S-7-F	225 mA	300 V		DUAL	SOT23-AKC	MMBD3004S-7-F	Diodes Inc.
16		13	D5, D41, D42, D43, D44, D45, D46, D47, D48, D50, D51, D52, D53	RED	25 mA	1.9 V		SMT, ChipLED	LED-HSMX-C170	HSMC-C170	Avago Technologies
17		4	D7, D9, D11, D13	STPS140Z	1.0 A	40 V		Schottky	SOD-123	STPS140Z	ST MICRO
18		1	D12	Bridge Rectifier	0.8 A	100 V		BRIDGE	MiniDIP4	HD01-T	Diodes Inc.
19		1	D54	BAV23A	400 mA	200 V		DUAL	SOT23-KKA	BAV23A	Diodes Inc.
20		9	FB1, FB2, FB3, FB4, FB6, FB7, FB8, FB9, FB11	600 Ω	200 mA			SMT	L0603	BLM18AG601SN1	MuRata
21		4	HD5, HD6, HD7, HD8	Screw					MH-125NP	NSS-4-4-01	Richco Plastic Co
22		4	HW1, HW2, HW3, HW4	Standoff					N/A	2397	SPC Technology
23		4	JP1, JP2, JP3, JP4	Header 5x1				Header	CONN1X5-TSW	TSW-105-07-T-S	Samtec
24		3	JP5, JP23, JP24	Header 1x3				Header	CONN-1X3	TSW-103-07-T-S	Samtec
25		9	JP6, JP7, JP8, JP9, JP10, JP12, JP13, JP14, JP15	Jumper				Header	CONN-1X2	TSW-102-07-T-S	Samtec
26		1	JP11	HEADER 4X1				Header	CONN-1X4	TSW-104-07-T-S	Samtec
27		1	JP16	4X1 Socket				Socket	CONN-1X4	SSW-104-01-T-S	Samtec
28		2	JP33, JP34	JUMPER				Unshrouded	CONN-1X2	68000-402	Berg
29		1	J1	RJ10 - Handset				Handset	RJ10-4P4C	806-GMX-N-44	Mouser
30		1	J2	RCA Jack				RCA	CONN-RCA-RCJ-04X	161-0097-E	Kobiconn

Si2494/39/38/37/36/35/29/19/18/17FT18-EVB

Table 7. MotherBoard Bill of Materials (Continued)

Item	NI	Qty	Ref	Value	Rating	Voltage	Tol	Type	PCB Footprint	Mfr Part Number	Mfr
31		1	J5	RJ-11				RJ-11	RJ11-DUAL-MTJG	MTJG-2-64-2-2-1	ADAM TECH
32		1	J6	HEADER 5x3				Header	CONN3X5	TSW-105-07-S-T	Samtec
34		1	J8	CONN TRBLK 2				TERM BLK	CONN-1X2-TB	1729018	PHOENIX CONTACT
35		1	J9	Power Jack	1 A			BARREL	CONN-3-PWR	ADC-002-1	Adam Tech
36		1	J10	DB9				D-SUB	CONN-9-DBF	D09S33E4GX00LF	FCI
37		1	J11	USB Type B				USB	CONN-USB-B	292304-1	Tyco
38		1	J30	5x2 Shrouded Header				Shrouded	CONN2X5-4W	5103309-1	Tyco
39		1	J101	HEADER 8x2				Header	CONN2X8	TSW-108-07-S-D	Samtec
40		1	J103	8x2 Shrouded Header				Shrouded	CONN2X8-4W	5103309-3	Tyco
41		1	K1	Relay	HV			DPDT	RLY-TXS2SA	FTR-C1GA4.5G	Fujitsu
42		1	LS1	Speaker	0.5 W Max				SPEAKER-RE2308NL	RE-2308-NL	Regal
43		1	MK1	Microphone					MIC-6X2.7mm	CMC-2742PBJ-A	CUI Inc
44		2	Q1 Q4	MMBTA06LT1	500 mA	80 V		NPN	SOT23-BEC	MMBTA06LT1	On Semi
45		1	Q3	FCX1051ATA	2 W	40 V		NPN	SOT89-BCE	FCX1051ATA	Zetex
46		1	Q5	MMBT3906-7-F	200 mA	40 V		PNP	SOT23-BEC	MMBT3906-7-F	Diodes Inc.
47		4	R1, R57, R98, R104	0.05 Ω	1/4 W		$\pm 5\%$	ThickFilm	R0805	LCR0805-R050J	Venkel
49		2	R3, R28	200 Ω	1/10 W		$\pm 1\%$	ThickFilm	R0603	CR0603-10W-2000F	Venkel
50		16	R4, R17, R19, R20, R25, R31, R40, R41, R42, R43, R52, R60, R87, R91, R109, R110, R111, R112, R113	10 k Ω	1/10 W		$\pm 1\%$	ThickFilm	R0603	CR0603-10W-1002F	Venkel
51		6	R5, R18, R36, R37, R38, R45	100 k Ω	1/10 W		$\pm 1\%$	ThickFilm	R0603	CR0603-10W-1003F	Venkel
52		4	R6, R7, R11, R21	2 k Ω	1/10 W		$\pm 1\%$	ThickFilm	R0603	CR0603-10W-2001F	Venkel
53		2	R9, R32	0 Ω	1A			ThickFilm	R0603	CR0603-16W-000	Venkel
54		1	R10	4.7 k Ω	1/16 W		$\pm 5\%$	ThickFilm	R0603	CR0603-16W-472J	Venkel
55		1	R12	5.1 k Ω	1/16 W		$\pm 5\%$	ThickFilm	R0603	CR0603-16W-512J	Venkel
56		2	R13, R24	50 k Ω				TRIM	POT-PV37W	PV37W503C01B00	Murata
57		5	R14, R16, R33, R34, R35	1 k Ω	1/16 W		$\pm 1\%$	ThickFilm	R0603	CR0603-16W-1001F	Venkel

Si2494/39/38/37/36/35/29/19/18/17FT18-EVB

Table 7. MotherBoard Bill of Materials (Continued)

Item	NI	Qty	Ref	Value	Rating	Voltage	Tol	Type	PCB Footprint	Mfr Part Number	Mfr
58		1	R15	49.9 k Ω	1/16 W		$\pm 0.5\%$	ThickFilm	R0603	CR0603-16W-4992D	Venkel
59		1	R22	499 Ω	1/10 W		$\pm 1\%$	ThickFilm	R0603	CR0603-10W-4990F	Venkel
60		3	R23, R29, R44	3.01 k Ω	1/16 W		$\pm 1\%$	ThickFilm	R0603	CR0603-16W-3011F	Venkel
61		1	R27	324 k Ω	1/10 W		$\pm 1\%$	ThickFilm	R0603	CR0603-10W-3243F	Venkel
62		1	R30	10 M Ω	1/16 W		$\pm 1\%$	ThickFilm	R0603	CR0603-16W-1005F	Venkel
64		1	R59	1 Ω	1/10 W		$\pm 1\%$	ThickFilm	R0603	CR0603-10W-1R00F	Venkel
65		2	R69, R70	0 Ω	10 A		0	Wire	RES-7MM	ZOR-12-R	Yageo
66		2	R84, R85	1.5 k Ω	1/16 W		$\pm 5\%$	ThickFilm	R0603	CR0603-16W-152J	Venkel
67		1	R96	3.57 Ω	1/10 W		$\pm 1\%$	ThickFilm	R0603	CR0603-10W-3R57F	Venkel
68		3	R97, R99, R101	200 Ω	1/10 W		$\pm 5\%$	ThickFilm	R0603	CR0603-10W-2000J	Venkel
69		2	R100, R102	1.33 K Ω	1/10 W		$\pm 1\%$	ThickFilm	R0603	CR0603-10W-1331F	Venkel
70		2	R103, R105	1.6 Ω	1/4 W		$\pm 5\%$	ThickFilm	R1206	CR1206-8W-1R6J	Venkel
72		11	R155, R156, R157, R158, R159, R160, R161, R162, R163, R169, R170	681 Ω	1/10 W		$\pm 1\%$	ThickFilm	R0603	CR0603-10W-6810F	Venkel
73		1	S1	SW Pushbutton	50 mA	12 Vdc		Tactile	SW4N6.5X4.5-PB	101-0161-EV	Mountain Switch
74		4	TP1, TP10, TP12, TP13	Red				Loop	Testpoint	151-207-RC	Kobiconn
75		5	TP2, TP7, TP8, TP9, TP25	Turret				Turret	TP[12594]	2551-2-00-44-00-00-07-0	Mill-Max
76		10	TP5, TP6, TP16, TP17, TP19, TP20, TP21, TP22, TP23, TP24,	Blue				Loop	Testpoint	151-205-RC	Kobiconn
78		2	U1, U3	LT1963A-3.3 V	1.5 A max			LDO	SOT223	LT1963AEST-3.3#PBF	Linear Technologies
79		1	U2	Si3000				VOICE CODEC	SO16N6.0P1.27	SI3000-KS	SiLabs
80		1	U4	LM4862					SO8N6.0P1.27	LM4862M	National Semiconductor
81		1	U5	EEPROM 32K				Serial	TSSOP8N6.4P0.65	25LC320A-I/ST	Microchip Technology
82		2	U8, U10	5	0.5 A max			LDO	TO263-3N	LM2937ES-5.0	National Semiconductors
83		1	U11	MAX3237		5.5 V		RS232	TSSOP28	MAX3237EIPWR	TI

Si2494/39/38/37/36/35/29/19/18/17FT18-EVB

Table 7. MotherBoard Bill of Materials (Continued)

Item	NI	Qty	Ref	Value	Rating	Voltage	Tol	Type	PCB Footprint	Mfr Part Number	Mfr
84		1	U12	CP2102				MCU	QFN28N5X5P0.5	CP2102-GM	SiLabs
85		2	U13, U14	IDT74CBTLV3257				MUX	TSSOP16N6.4P0.65	IDT74CBTLV3257PG G	IDT
86		1	U18	DS1818		3.3 V	10%		SOT-23	DS1818-10	Dallas Semicon- ductor
87		3	U20, U21, U22	AD8602ARM					SOP8N4.9P0.65	AD8602ARM	Analog Devices
88		1	U26	74LCX541				Buffer	TSSOP20N6.4P0.65	74LCX541MTC	Fairchild
89		1	U27	MAX4521					TSSOP16N6.4P0.65	MAX4521CUE+	Maxim

Table 8. Motherboard Bill of Materials (Non-Populated Footprints)

Item	Qty	Reference	Value	Rating	Tol	Dielectric	PCB Footprint	Manufacturer Part Number	Manufacturer
91	3	R1,R73,R102	0R	1/16 W			RC0603	CR0603-16W-000T	Venkel
92	2	R31,R32	10k	1/16 W	±5%		RC0603	CR0603-16W-103JT	Venkel
93	1	C10	10 uF	10 V	±10 %	X7R	CC0805	GRM21BR71A106KE51L	Murata

Si2494/39/38/37/36/35/29/19/18/17FT18-EVB

7.2. Daughter Card Bill of Materials

Table 9. Si24xx Daughter Card Bill of Materials

Item	Qty	Ref	Value	Rating	Voltage	Tol	Type	PCB Footprint	Mfr Part Number	Mfr
1	2	C1, C2	33 pF	Y2	250 V	±10%	Y2	C1808	SCC1808X330K502T	Holy Stone
2	1	C3	0.01 µF		250 V	±10%	X7R	C0805	GRM21BR72E103KW03L	Murata
3	1	C4	1 µF		50 V	±20%	Alum_Elec	C3.3X3.3MM	EEE1HS010SR	Panasonic
4	2	C5, C6	0.1 µF		16 V	±20%	X7R	C0603	C0603X7R160-104M	Venkel
5	1	C7	2.7 nF		50 V	±20%	X7R	C0603	C0603X7R500-272M	Venkel
6	2	C8, C9	680 pF	Y2	250 V	±10%	Y2	C1808	SCC1808X681K502T	Holy Stone
7	1	C10	0.01 µF		16 V	±20%	X7R	C0603	C0603X7R160-103M	Venkel
8	2	C40, C41	18 pF		50 V	±5%	COG	C0603	C0603COG500-180J	Venkel
9	3	C50, C52, C56	0.1 µF		10 V	±20%	X7R	C0603	C0603X7R100-104M	Venkel
10	2	C51, C53	0.22 µF		6.3 V	±10%	X5R	C0603	C0603X7R6R3-224K	Venkel
11	1	C54	1 µF		25 V	±10%	X5R	C0603	C0603X5R250-105K	Venkel
12	1	D1	HD04	0.8 A	400 V		BRIDGE	MiniDIP4	HD04-T	Diodes Inc.
13	3	FB1, FB2, FB5	600 Ω	200 mA			SMT	L0603	BLM18AG601SN1	Murata
14	1	J1	SOCKET 8x2				SOCKET	SOCKETX8-100-SMT	SSW-108-22-G-D-VS	Samtec
15	1	J2	4X1 Header_0					CONN1X4-100-SMT	TSM-104-01-T-SV	Berg
16	2	Q1 Q3	MMBTA42LT1	200 mA	300 V		NPN	SOT23-BEC	MMBTA42LT1	On Semi
17	1	Q2	MMBTA92LT1	100 mA	300 V		PNP	SOT23-BEC	MMBTA92LT1	On Semi
18	2	Q4 Q5	MMBTA06LT1	500 mA	80 V		NPN	SOT23-BEC	MMBTA06LT1	On Semi
19	1	RV1	P3100SB		275 V		Sidactor	DO-214AA-NP	P3100SBL	Littelfuse
20	1	R1	1.07 kΩ	1/2 W		±1%	ThickFilm	R2010	CR2010-2W-1071F	Venkel
21	1	R2	150 Ω	1/16 W		±5%	ThickFilm	R0603	CR0603-16W-151J	Venkel
22	1	R3	3.65 kΩ	1/2 W		±1%	ThickFilm	R2010	CR2010-2W-3651F	Venkel
23	1	R4	2.49 kΩ	1/2 W		±1%	ThickFilm	R2010	CR2010-2W-2491F	Venkel
24	2	R5, R6	100 kΩ	1/16 W		±5%	ThickFilm	R0603	CR0603-16W-104J	Venkel
25	2	R7, R8	20 MΩ	1/8 W		±5%	ThickFilm	R0805	CR0805-8W-206J	Venkel
26	1	R9	1 MΩ	1/16 W		±1%	ThickFilm	R0603	CR0603-16W-1004F	Venkel
27	1	R10	536 Ω	1/4 W		±1%	ThickFilm	R1206	CR1206-4W-5360F	Venkel
28	1	R11	73.2 Ω	1/2 W		±1%	ThickFilm	R2010	CR2010-2W-73R2F	Venkel
29	2	R12, R13	56.2 Ω	1/16 W		±1%	ThickFilm	R0603	CR0603-16W-56R2F	Venkel
30	2	R15, R16	0 Ω	1 A			ThickFilm	R0603	CR0603-16W-000	Venkel
31	2	R120, R121	0 Ω	1 A			ThickFilm	R0603	CR0603-16W-000	Venkel
32	1	R18	1.2 kΩ	1/10 W		±5%	ThickFilm	R0603	CR0603-10W-121J	Venkel
33	4	R101, R102, R103, R104, R106	10 kΩ	1/10 W		±5%	ThickFilm	R0603	CR0603-10W-103J	Venkel
34	1	R105	1 kΩ	1/10 W		±5%	ThickFilm	R0603	CR0603-10W-102J	Venkel

Si2494/39/38/37/36/35/29/19/18/17FT18-EVB

Table 9. Si24xx Daughter Card Bill of Materials (Continued)

Item	Qty	Ref	Value	Rating	Voltage	Tol	Type	PCB Footprint	Mfr Part Number	Mfr
35	3	R110, R111, R112	200 Ω	1/10 W		$\pm 5\%$	ThickFilm	R0603	CR0603-10W-2000J	Venkel
36	1	U2	Si3018		300 V		LineSide	SO16N6.0P1.27	Si3018-F-GS	SiLabs
37	1	U12	Si24xx				ISOMODEM	TSSOP24N6.4P0.65	Si2493-E-FT	SiLabs
38	1	U13	Si24xx					16pin SOIC	Si24xx	Silicon Laboratories
39	1	Y1B (Y1, Y3)	32.768 kHz					XTAL-3X8-LD	ECS-327-12.5-8X	ECS International
40	1	Z1	43 V	500 mW	43 V		Zener	SOD-123	BZT52C43-7-F	Diodes Inc.

Table 10. Daughter Card Bill of Materials (Non-Populated Footprints)

Item	Qty	Reference	Value	Rating	Tol	Dielectric	PCB Footprint	Manufacturer Part Number	Manufacturer
1	1	C50	0.1 μF	16 V	$\pm 20\%$	X7R	CC0603	C0603X7R160-104MNE	Venkel
2	2	C55,C56	0.1 μF	10 V	$\pm 20\%$	X7R	CC0603	C0603C124K	Kemet
3	1	R18	1.3 k Ω	1/16 W	$\pm 5\%$		RC0603	CR0603-16W-132JT	Venkel
4	5	R19,R20, R21,R22,R23	0 Ω	1/16W	$\pm 5\%$		RC0603	CR0603-16W-000J	Venkel
5	1	U4	Si2401				16pin SOIC		Silicon Labs

Si2494/39/38/37/36/35/29/19/18/17FT18-EVB

7.3. QFN Daughter Card Bill of Materials

Table 11. Si24xx QFN Daughter Card Bill of Materials

Item	Qty	Ref	Value	Rating	Voltage	Tol	Type	PCB Footprint	Mfr Part Number	Mfr
1	2	C1, C2	33 pF	Y2	250 V	±10%	Y2	C1808	SCC1808X330K502T	Holy Stone
2	1	C3	0.01 µF		250 V	±10%	X7R	C0805	C0805X7R251-103K	Venkel
3	1	C4	1 µF		50 V	±20%	Alum_Elec	C3.3X3.3MM	EEE1HS010SR	Panasonic
5	2	C5, C6	0.1 µF		16 V	±20%	X7R	C0603	C0603X7R160-104M	Venkel
6	1	C7	2.7 nF		50 V	±20%	X7R	C0603	C0603X7R500-272M	Venkel
7	2	C8, C9	680 pF	Y2	250 V	±10%	Y2	C1808	SCC1808X681K502T	Holy Stone
8	1	C10	0.01 µF		16 V	±20%	X7R	C0603	C0603X7R160-103M	Venkel
9B	2	C40, C41	18 pF		50 V	±5%	COG	C0603	C0603COG500-180J	Venkel
10	5	C50, C52, C55, C56, C57	0.1 µF		10 V	±10%	X7R	C0402	C0402X7R100-104K	Venkel
11	1	C51	0.22 µF		10 V	±10%	X7R	C0603	C0603X7R100-224K	Venkel
12	1	C54	1 µF		25 V	±10%	X5R	C0603	C0603X5R250-105K	Venkel
13	1	D1	HD04	0.8 A	400 V		BRIDGE	MiniDIP4	HD04-T	Diodes Inc.
14	3	FB1, FB2, FB5	600 Ω	200 mA			SMT	L0603	BLM18AG601SN1	MuRata
15	2	JP1, JP2	JUMPER				Header	CONN-1X2	TSW-102-07-T-S	Samtec
16	1	J1	SOCKET 8x2				SOCKET	SOCKETX8-100-SMT	SSW-108-22-G-D-VS	Samtec
17	1	J2	4X1 Header				SMT	CONN1X4-TSM	TSM-104-01-T-SV	Samtec
18	2	Q1, Q3	MMBTA42LT1	200 mA	300 V		NPN	SOT23-BEC	MMBTA42LT1	On Semi
19	1	Q2	MMBTA92LT1	100 mA	300 V		PNP	SOT23-BEC	MMBTA92LT1	On Semi
20	2	Q4, Q5	MMBTA06LT1	500 mA	80 V		NPN	SOT23-BEC	MMBTA06LT1	On Semi
21	1	RV1	P3100SB		275 V		Sidactor	DO-214AA-NP	P3100SBL	Littelfuse
22	1	R1	1.07 kΩ	1/2 W		±1%	ThickFilm	R2010	CR2010-2W-1071F	Venkel
23	1	R2	150 Ω	1/16 W		±5%	ThickFilm	R0603	CR0603-16W-151J	Venkel
24	1	R3	3.65 kΩ	1/2 W		±1%	ThickFilm	R2010	CR2010-2W-3651F	Venkel
25	1	R4	2.49 kΩ	1/2 W		±1%	ThickFilm	R2010	CR2010-2W-2491F	Venkel
26	2	R5, R6	100 kΩ	1/16 W		±5%	ThickFilm	R0603	CR0603-16W-104J	Venkel
27	2	R7, R8	20 MΩ	1/8 W		±5%	ThickFilm	R0805	CR0805-8W-206J	Venkel
28	1	R9	1 MΩ	1/16 W		±1%	ThickFilm	R0603	CR0603-16W-1004F	Venkel
29	1	R10	536 Ω	1/4 W		±1%	ThickFilm	R1206	CR1206-4W-5360F	Venkel
30	1	R11	73.2 Ω	1/2 W		±1%	ThickFilm	R2010	CR2010-2W-73R2F	Venkel
31	2	R12, R13	56.2 Ω	1/16 W		±1%	ThickFilm	R0603	CR0603-16W-56R2F	Venkel
32	2	R15, R16	0	1 A			ThickFilm	R0603	CR0603-16W-000	Venkel

Si2494/39/38/37/36/35/29/19/18/17FT18-EVB

Table 11. Si24xx QFN Daughter Card Bill of Materials

Item	Qty	Ref	Value	Rating	Voltage	Tol	Type	PCB Footprint	Mfr Part Number	Mfr
33	1	R18	1.2 k Ω	1/16 W		$\pm 5\%$	ThickFilm	R0402	CR0402-16W-122J	Venkel
34	2	R101, R104	10 k Ω	1/10 W		$\pm 5\%$	ThickFilm	R0603	CR0603-10W-103J	Venkel
36	1	R122	0	1 A			ThickFilm	R0402	CR0402-16W-000	Venkel
38	1	U1	Si2494/39				ISOMODEM	QFN38N5X7P0.5	Si2494-A-FM/Si2439-A-FM	SiLabs
39	1	U2	Si3018		300 V		LineSide	SO16N6.0P1.27	Si3018-F-GS	SiLabs
40	1	U3	EEPROM 32K				Serial	TSSOP8N6.4P0.65	25LC320A-I/ST	Microchip Technology
41	1	Y1A	32.768 kHz					XTAL-3X8-LD	ECS-.327-12.5-8X	ECS International
44	1	Z1	43 V	500 mW	43 V		Zener	SOD-123	BZT52C43-7-F	Diodes Inc.

Table 12. Si24xx QFN Daughter Card Bill of Materials (Non-Populated Footprints)

Item	Qty	Ref	Value	Rating	Voltage	Tol	Type	PCB Footprint	Mfr Part Number	Mfr
4	1	C4X	1 μ F		25 V	$\pm 10\%$	X8R	C1206	C3216X8R1E105K	TDK
9	2	C40, C41	33 pF		50 V	$\pm 5\%$	COG	C0402	C0402COG500-330J	Venkel
32B	2	R120, R121	0 Ω	1 A			ThickFilm	R0603	CR0603-16W-000	Venkel
34	1	R103	10 k Ω	1/10 W		$\pm 5\%$	ThickFilm	R0603	CR0603-10W-103J	Venkel
35	1	R102	1 k Ω	1/10 W		$\pm 5\%$	ThickFilm	R0603	CR0603-10W-1001J	Venkel
36B	1	R123	0 Ω	1 A			ThickFilm	R0402	CR0402-16W-000	Venkel
42	1	Y1B	4.9152 MHz					XTAL-HC49U-SMT	FOXSDLF/049-20	FOX Electronic
43	1	Y1C	27 MHz		3.3 V		XTAL OSC	OSC4N5X3.2-FOX924	FOX924B-27.000	FOX

8. Complete Design Package on CD

(See Sales Representative for Details)

Silicon Laboratories can provide a complete design package of the Voice ISOmodem EVB including the following:

- OrCad Schematics
- Gerber Files

Please contact your local sales representative or Silicon Laboratories headquarters sales for ordering information.

DOCUMENT CHANGE LIST

Revision 0.1 to Revision 0.2

- Updated Voice Motherboard description, schematics, silkscreens, and configuration from 1.0 to 2.0 revision.
- Updated Daughtercard description, schematics, silkscreens, and configuration.
- Added support for Si2494/39 voice and data modems.
- Updated "Description" on page 1.
- Updated "2.Daughter Cards" on page 4.
- Added "4.1.7.Surge Protection Circuits" on page 24.
- Updated "4.1.8.2.The Call Progress Signal" on page 26.
- Updated "4.2.Daughter Cards" on page 28.
- Added "4.2.4.Daughter Card Strapping and Jumper Options" on page 29.
- Added "7.3.QFN Daughter Card Bill of Materials" on page 59.
- Added "8.Complete Design Package on CD" on page 61.
- Updated Figure 5, "Function and Location of Global Voice ISOmodem EVB Jumpers," on page 6.
- Updated Figure 29 on page 34.
- Added Figure 31, "QFN Daughter Card (Si24xx2G-QFN38-DC Rev 1.0) System Side," on page 36.
- Added Figure 32, "Daughter Card (Si24xx2G-QFN38-DC Rev 1.0) Line Side," on page 37.
- Added Figure 43, "QFN Daughter Card Primary Side, Component and Silkscreen," on page 48.
- Added Figure 44, "QFN Daughter Card Secondary Side, Component and Silkscreen," on page 49.
- Added Figure 45, "QFN Daughter Card Primary Side," on page 50.
- Added Figure 46, "QFN Daughter Card Secondary Side," on page 51.
- Updated Table 2, "Digital Data Related Jumpers," on page 7.
- Added Table 11, "Si24xx QFN Daughter Card Bill of Materials," on page 59.
- Added Table 12, "Si24xx QFN Daughter Card Bill of Materials (Non-Populated Footprints)," on page 60.

Revision 0.2 to Revision 0.3

- Updated Table 3, "Sound Related Jumpers," on page 8.
- Corrected R13 adjustment information.
- Changed obsolete references, such as "JP5".
- Updated Table 5, "Board Configuration," on page 21.
 - Added missing jumper information.

Revision 0.3 to Revision 0.4

- Updated "3.3.USB Interface Data Link Setup Quick Start" on page 9.
 - Removed JP5 reference.

NOTES:

CONTACT INFORMATION

Silicon Laboratories Inc.
400 West Cesar Chavez
Austin, TX 78701
Tel: 1+(512) 416-8500
Fax: 1+(512) 416-9669
Toll Free: 1+(877) 444-3032

Please visit the Silicon Labs Technical Support web page:
<https://www.silabs.com/support/pages/contacttechnicalsupport.aspx>
and register to submit a technical support request.

The information in this document is believed to be accurate in all respects at the time of publication but is subject to change without notice. Silicon Laboratories assumes no responsibility for errors and omissions, and disclaims responsibility for any consequences resulting from the use of information included herein. Additionally, Silicon Laboratories assumes no responsibility for the functioning of undescribed features or parameters. Silicon Laboratories reserves the right to make changes without further notice. Silicon Laboratories makes no warranty, representation or guarantee regarding the suitability of its products for any particular purpose, nor does Silicon Laboratories assume any liability arising out of the application or use of any product or circuit, and specifically disclaims any and all liability, including without limitation consequential or incidental damages. Silicon Laboratories products are not designed, intended, or authorized for use in applications intended to support or sustain life, or for any other application in which the failure of the Silicon Laboratories product could create a situation where personal injury or death may occur. Should Buyer purchase or use Silicon Laboratories products for any such unintended or unauthorized application, Buyer shall indemnify and hold Silicon Laboratories harmless against all claims and damages.

Silicon Laboratories, Silicon Labs, and ISModem are trademarks of Silicon Laboratories Inc.
Other products or brandnames mentioned herein are trademarks or registered trademarks of their respective holders.



Компания «ЭлектроПласт» предлагает заключение долгосрочных отношений при поставках импортных электронных компонентов на взаимовыгодных условиях!

Наши преимущества:

- Оперативные поставки широкого спектра электронных компонентов отечественного и импортного производства напрямую от производителей и с крупнейших мировых складов;
- Поставка более 17-ти миллионов наименований электронных компонентов;
- Поставка сложных, дефицитных, либо снятых с производства позиций;
- Оперативные сроки поставки под заказ (от 5 рабочих дней);
- Экспресс доставка в любую точку России;
- Техническая поддержка проекта, помощь в подборе аналогов, поставка прототипов;
- Система менеджмента качества сертифицирована по Международному стандарту ISO 9001;
- Лицензия ФСБ на осуществление работ с использованием сведений, составляющих государственную тайну;
- Поставка специализированных компонентов (Xilinx, Altera, Analog Devices, Intersil, Interpoint, Microsemi, Aeroflex, Peregrine, Syfer, Eurofarad, Texas Instrument, Miteq, Cobham, E2V, MA-COM, Hittite, Mini-Circuits, General Dynamics и др.);

Помимо этого, одним из направлений компании «ЭлектроПласт» является направление «Источники питания». Мы предлагаем Вам помощь Конструкторского отдела:

- Подбор оптимального решения, техническое обоснование при выборе компонента;
- Подбор аналогов;
- Консультации по применению компонента;
- Поставка образцов и прототипов;
- Техническая поддержка проекта;
- Защита от снятия компонента с производства.



Как с нами связаться

Телефон: 8 (812) 309 58 32 (многоканальный)

Факс: 8 (812) 320-02-42

Электронная почта: org@eplast1.ru

Адрес: 198099, г. Санкт-Петербург, ул. Калинина, дом 2, корпус 4, литера А.