

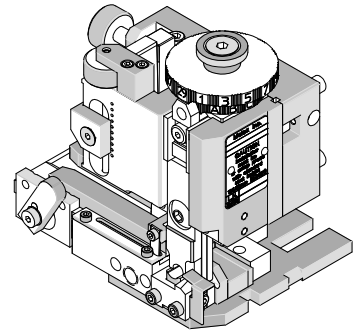

Mini-Mac Applicator Application Tooling Specification Mechanical Feed-Front Metal Strip Order No. 63895-1000



FEATURES

- Directly adapts to most automatic wire processing machines
- Applicator designed to industry standard mounting and shut height 135.80mm (5.346")
- Quick set-up time; plus the crimp height, track and feed adjustments can be set without removing the applicator from the press
- Fine adjustment allows users to achieve target with little effort by adjusting in increments of .015mm (.0006") for conductor crimp height and .063mm (.0025") for insulation height
- Independent adjustment rings allow users to quickly adjust the conductor or insulation crimp height without affecting each other.

SCOPE

Products: CP2.8 and CPX2.8 Receptacle Crimp Terminals, >2.0 – 3.0 mm² type ID and IR wire.

Terminal Series No.	Terminal Order No.		Wire Size and Type		✗ Insulation Diameter		Strip Length	
			mm ²	Type	mm	In.	mm	In.
98910	98910-1029	98910-1129	>2.0 – 3.0	ID & IR	2.65-3.45	.104-.136	4.90-5.10	.193-.201
	98910-2029	98910-2129						
64324	64324-1029	64324-1129	>2.0 – 3.0	ID & IR	2.65-3.45	.104-.136	4.90-5.10	.193-.201
	64324-2029	64324-2129						

✗ See crimp specification for the individual Insulation Diameter.

DEFINITION OF TERMS

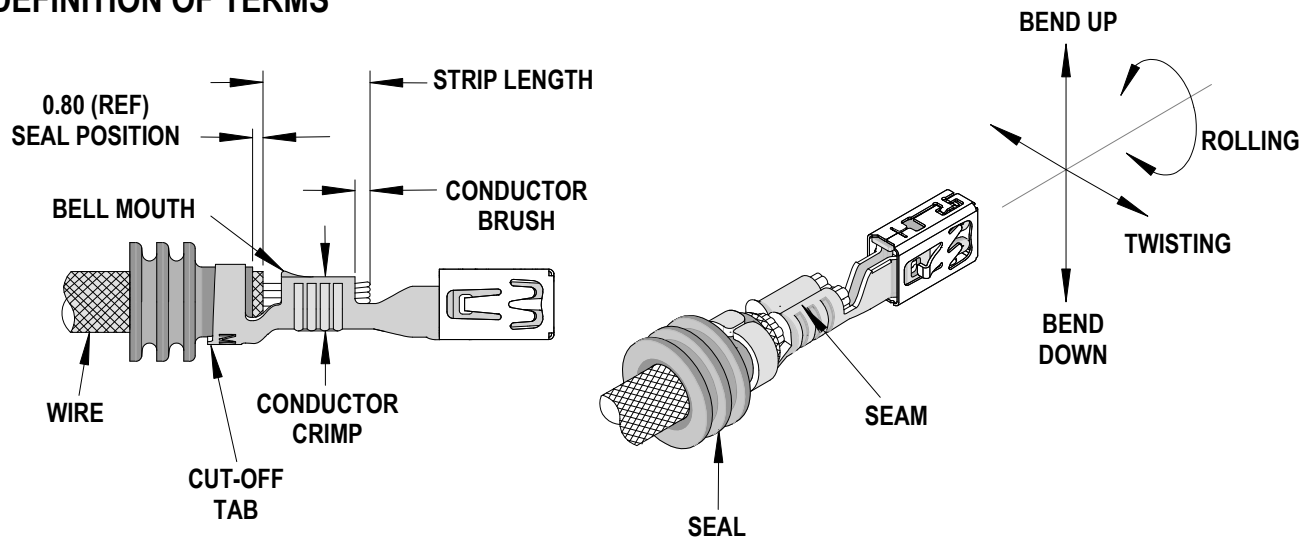

The above terminal drawing is a generic terminal representation. It is not an image of any terminal listed in the scope.

CRIMP SPECIFICATION

Terminal Series No.	Bell mouth		Cut-off Tab Maximum		*Conductor Brush	
	mm	In.	mm	In.	mm	In.
98910	0.40-0.60	.016-.024	0.30	.012	0.20-0.60	.008-.024
64324	0.40-0.60	.016-.024	0.30	.012	0.20-0.60	.008-.024

*Not to exceed above the conductor crimp height.

Terminal Series No.	Bend up	Bend down	Twist	Roll	Punch Width (Ref)				Seam Seam shall not be open and no wire allowed out of the crimping area
	Degree		Degree		Conductor		Insulation		
	mm	In	mm	In	mm	In	mm	In	
98910	2	2	2	3	2.80	.110	4.85	.191	
64324	2	2	2	3	2.80	.110	4.85	.191	

After crimping, the crimp profiles should measure the following:

Terminal Series No.	Wire Size mm ²	Conductor				Pull Force Minimum	
		Crimp Height		Crimp Width (Ref.)		N	Lb.
		mm	In.	mm	In.		
98910	2.50	1.80-1.90	.071-.075	2.89	.114	235.0	52.8
	3.00	1.95-2.05	.077-.081	2.90	.114	260.0	58.5
64324	2.50	1.80-1.90	.071-.075	2.89	.114	235.0	52.8
	3.00	1.95-2.05	.077-.081	2.90	.114	260.0	58.5

Terminal Series No.	Wire Size mm ²	*Insulation Diameter		Single Wire Seal		Insulation			
		mm	In.	Order No.	Color	Crimp Height		Crimp Width (Ref.)	
						mm	In.	mm	In.
98910	2.50	2.65-3.00	.104-.118	0643251188	Grey	4.80-5.00	.189-.197	5.02	.198
	3.00	3.25-3.45	.128-.136			5.10-5.30	.201-.209	5.05	.199
64324	2.50	2.65-3.00	.104-.118	0643251188	Grey	4.80-5.00	.189-.197	5.02	.198
	3.00	3.25-3.45	.128-.136			5.10-5.30	.201-.209	5.05	.199

*** Tool Qualification Notes:**

1. Pull Force should be measured with no influence from the insulation crimp.
2. The above specifications are guidelines to an optimum crimp.

PARTS LIST

Mini-Mac Applicator 63895-1000				
Item	Order No	Engineering No.	Description	Quantity
Perishable Tooling				
	63895-1070	63895-1070	Tool Kit (All "Y" Items)	REF
1	63465-0058	63465-0058	Conductor Punch	1 Y
2	63455-0061	63455-0061	Conductor Anvil	1 Y
3	63463-0038	63463-0038	Insulation Punch	1 Y
4	63456-0055	63456-0055	Insulation Anvil	1 Y
5	63443-0037	63443-0037	Cut-off Plunger Front	1 Y
6	63443-0038	63443-0038	Plunger Retainer Front	1 Y
Other Components				
7	11-18-4094	60709A111	Feed Guide	1
8	63443-0009	63443-0009	Scrap Chute Front	1
9	63443-0024	63443-0024	Key	1
10	63443-0090	63443-0090	Wire Stop	1
11	63443-1712	63443-1712	18.20mm Height Spacer	1
12	63443-2201	63443-2201	1.00mm Course Spacer	1
13	63443-2214	63443-2214	14.00mm Course Spacer	1
14	63443-2312	63443-2312	3.60mm Fine Spacer	1
15	63443-6121	63443-6121	Rear Cover	1
16	63443-3701	63443-3701	Striker Screw	1
17	63443-3801	63443-3801	Front Plunger Striker	1
18	63700-0225	63700-0225	Compression Spring	1
19	63700-0539	63700-0539	Cut-Off Plunger Spring	1
20	63890-0063	63890-0063	Terminal Hold Down-For CP2.8	1
21	63890-0067	63890-0067	Holder Front	1
22	63890-0068	63890-0068	Holder Rear	1
23	63890-0866	63890-0866	Collar-6.40 Long	2
Frame				
24	63801-3201	63801-3201	Top	1
25	63801-3281	63801-3281	Base	1
26	63801-4650	63801-4650	Track	1
Hardware				
27	N/A	N/A	M3 by 5 Long Flat Point SSS	2**
28	N/A	N/A	M3 by 6 Long FHCS	1**
29	N/A	N/A	M3 by 6 Long SHCS	2**
30	N/A	N/A	M3 by 10 Long SHCS	1**
31	N/A	N/A	M4 by 6 Long SHCS	2**
32	N/A	N/A	M4 by 12 Long BHCS	2**
33	N/A	N/A	M4 by 16 Long SHCS	2**
34	N/A	N/A	M4 by 55 Long SHCS	2**
35	N/A	N/A	M5 by 12 Long SHCS	1**
36	N/A	N/A	M8 by 30 Long BHCS	1**
37	N/A	N/A	2mm by 8 Long Dowel Pin	1**

** Available from an industrial supply company such as MSC (1-800-645-7270).

Assembly Drawing

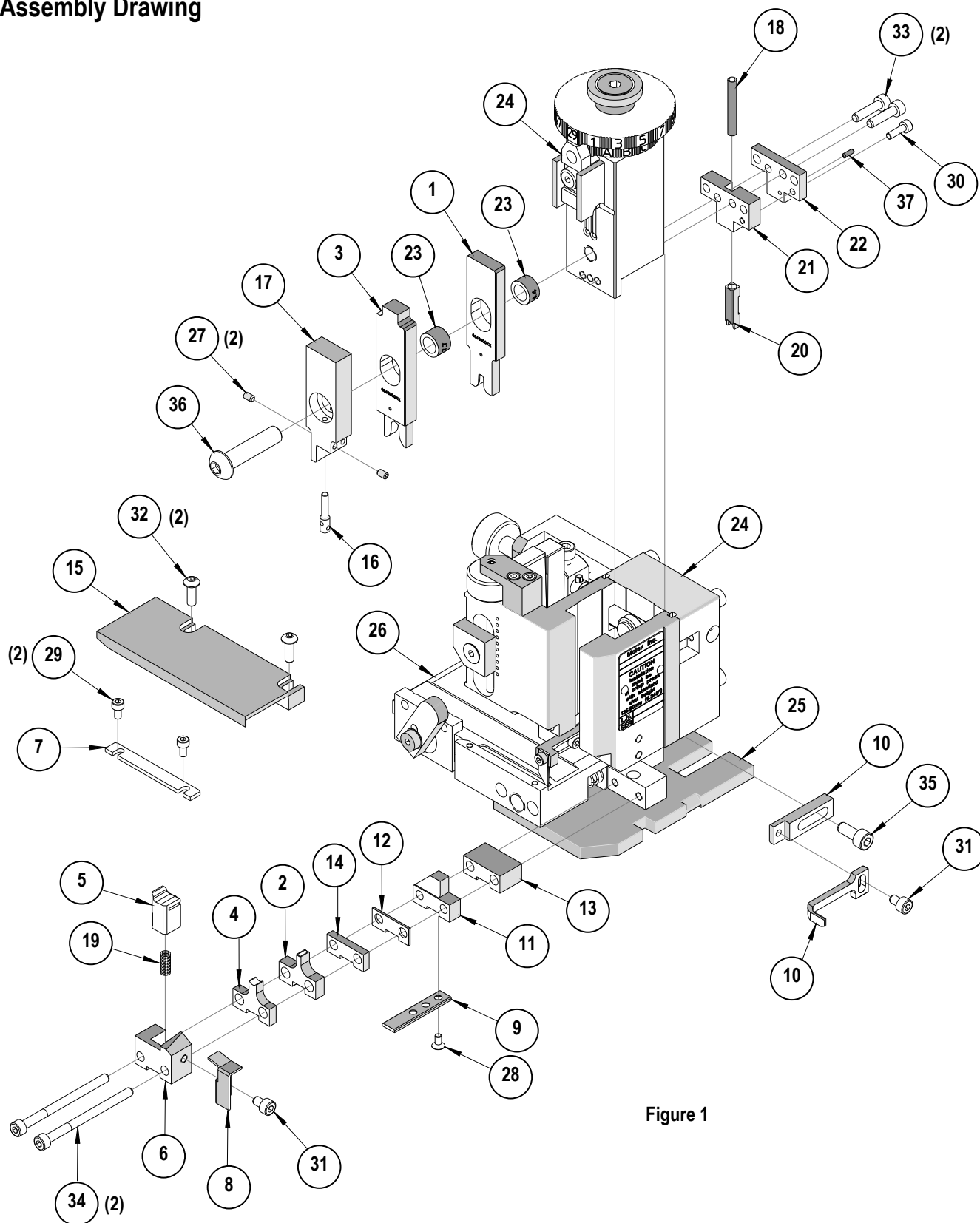

Figure 1

NOTES

1. Molex recommends an extra perishable tooling kit be maintained at your facility.
2. Verify tooling alignment by manually cycling the press with applicator before crimping under power. Check that all screws are tight.
3. Slugs, terminals, dirt, and oil should be kept clear of work area.
4. Wear safety glasses at all times.
5. For recommended maintenance refer to the Mini-Mac Applicator Manual (Document no. 63880-0000).

CAUTION: This applicator should only be used in a press with a shut height of 135.80 mm (5.346"). Tooling damage could result at a lower setting.

CAUTION: To prevent injury, never operate this applicator without the guards supplied with the press or wire-processing machine in place. Reference the press or wire processing manufacturer's instruction manual.

CAUTION: Molex crimp specifications are valid only when used with Molex terminals, applicators and tooling.

Contact Information

For more information on Molex application tooling please contact Molex at 1-800-786-6539.

Americas Headquarters
Lisle, Illinois 60532 U.S.A.
1-800-78MOLEX
amerinfo@molex.com

Far East North Headquarters
Yamato, Kanagawa, Japan
81-462-65-2324
feninfo@molex.com

Far East South Headquarters
Jurong, Singapore
65-6-268-6868
fesinfo@molex.com

European Headquarters
Munich, Germany
49-89-413092-0
eurinfo@molex.com

Corporate Headquarters
2222 Wellington Ct.
Lisle, IL 60532 U.S.A.
630-969-4550
Fax: 630-969-1352

Visit our Web site at <http://www.molex.com>



Компания «ЭлектроПласт» предлагает заключение долгосрочных отношений при поставках импортных электронных компонентов на взаимовыгодных условиях!

Наши преимущества:

- Оперативные поставки широкого спектра электронных компонентов отечественного и импортного производства напрямую от производителей и с крупнейших мировых складов;
- Поставка более 17-ти миллионов наименований электронных компонентов;
- Поставка сложных, дефицитных, либо снятых с производства позиций;
- Оперативные сроки поставки под заказ (от 5 рабочих дней);
- Экспресс доставка в любую точку России;
- Техническая поддержка проекта, помощь в подборе аналогов, поставка прототипов;
- Система менеджмента качества сертифицирована по Международному стандарту ISO 9001;
- Лицензия ФСБ на осуществление работ с использованием сведений, составляющих государственную тайну;
- Поставка специализированных компонентов (Xilinx, Altera, Analog Devices, Intersil, Interpoint, Microsemi, Aeroflex, Peregrine, Syfer, Eurofarad, Texas Instrument, Miteq, Cobham, E2V, MA-COM, Hittite, Mini-Circuits, General Dynamics и др.);

Помимо этого, одним из направлений компании «ЭлектроПласт» является направление «Источники питания». Мы предлагаем Вам помощь Конструкторского отдела:

- Подбор оптимального решения, техническое обоснование при выборе компонента;
- Подбор аналогов;
- Консультации по применению компонента;
- Поставка образцов и прототипов;
- Техническая поддержка проекта;
- Защита от снятия компонента с производства.



Как с нами связаться

Телефон: 8 (812) 309 58 32 (многоканальный)

Факс: 8 (812) 320-02-42

Электронная почта: org@eplast1.ru

Адрес: 198099, г. Санкт-Петербург, ул. Калинина, дом 2, корпус 4, литера А.