

Right Angle 2.0mm Pitch Connector

9155-700



AVX extends their board-to-board right angle connectors with a new 2mm pitch version 9155-700, an addition to the existing versions 9155-300 with a 3mm pitch and 9155-500 with a 2.5mm pitch. This new connector is offered in 2 to 6 contact positions and rated at 2 Amps for the 2-4 way versions or 1.5 Amps for the 5-6 way versions. The connector's design is small and compact in order to minimize its profile, yet remain stable while having a contact point at 2.10mm above the PCB.

The stability comes from extra SMT anchor brackets. In addition to existing versions, the new connector has two options without or with locating bosses, providing even better mechanical stability on the PCB.

The complete family of connectors 9155 series from AVX offer all the same advantages : Ultra reliable and robust gold plated beryllium copper contacts provide high integrity connections in harsh environments, with 5000 mating operations, high temperature nylon plastic for RoHS soldering.

APPLICATIONS

- Handheld/portable devices requiring docking or cradle charging
- Patient monitoring or portable medical electronics
- Industrial devices requiring pluggable or programming modules
- Internet appliances requiring battery back-up

FEATURES AND BENEFITS

- Simple designed compact 2mm pitch right angle connector up to 6 positions
- Gold plated BeCu contacts provide high electrical and mechanical performance over 5000 mating cycles
- Two anchor brackets for mechanical stability
- Optional plastic locating bosses with SMT anchor tabs maximizes the mechanical stability of the connector in harsh conditions

ELECTRICAL

- Current Rating: 2p-4p: 2.0 Amps, 5p-6p: 1.5 Amps
- Voltage Rating: 125 VAC

ENVIRONMENTAL

- Operating Temperature: -40°C to +125°C

MECHANICAL

- Insulator Material: Glass-Filled Nylon 46; UL94V0
- Contact Material: Beryllium Copper
- Plating: Gold over Nickel, Tin leads
- Durability: 5000 Cycles

HOW TO ORDER

00
Prefix

9155
Series

00X
No of Ways

Code	No of Ways	Qty Per Reel	
		Without Boss	With Boss
002	2	1000	1000
003	3	1000	1000
004	4	1000	1000
005	5	1000	1000
006	6	1000	1000

7XX
Standard Battery Connector

Code	Description	Operating Height	Boss
741	Battery Connector Right Angle	4.00mm	No
742	Battery Connector Right Angle	4.00mm	Yes

00

X

Plating Option

- 6 = 0.4µm Selective Gold, Pure Tin Tail
- 8 = 0.8µm Selective Gold, Pure Tin Tail



Right Angle 2.0mm Pitch Connector

9155-700



2 WAY BATTERY CONNECTOR – RIGHT ANGLE 2MM PITCH – WITHOUT BOSS

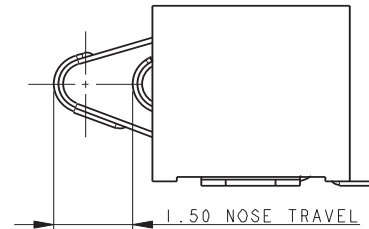
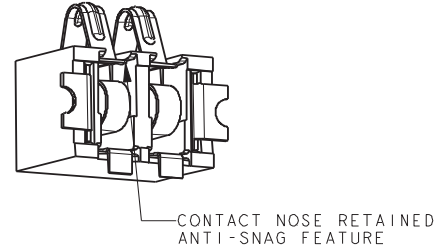
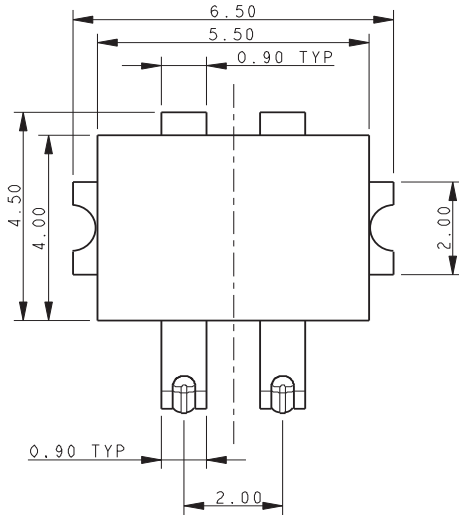

DEFLECTED CONNECTOR

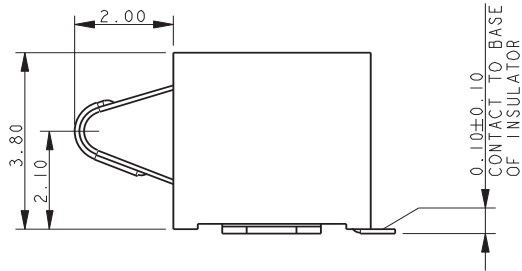
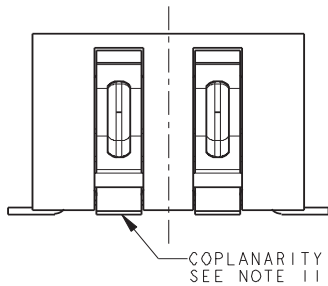

UNDEFLECTED CONTACT

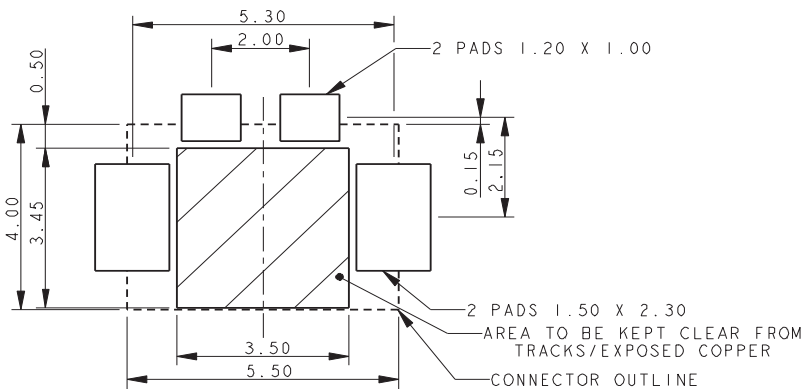

SUGGESTED PCB LAYOUT

NOTES:

1. GENERAL TOLERANCE ± 0.20 UNLESS OTHERWISE STATED.
2. FOR FULL PRODUCT SPECIFICATION REFER TO AVX SPEC 201-01-203.
3. FOR MATING PAD DETAILS REFER TO PAGE 13.
4. PACKING DETAILS ON PAGE 12.
5. INSULATOR MATERIAL: GLASS FILLED NYLON 46, UL94 V-0, COLOR BLACK.
6. CONTACT MATERIAL: BERYLLIUM COPPER.
7. CONTACT PLATING; SELECTIVE GOLD OVER NICKEL, PURE TIN ON TAILS.
8. BRACKET MATERIAL; PHOSPHOR BRONZE.
9. BRACKET PLATING; PURE TIN OVER NICKEL.
10. NOMINAL CONTACT FORCE 90 GRAMS AT 1.50 DEFLECTION.
11. COPLANARITY OF ALL CONTACT TAILS AND PADS 0.10MM MAXIMUM.

Right Angle 2.0mm Pitch Connector

9155-700

2 WAY BATTERY CONNECTOR – RIGHT ANGLE 2MM PITCH – WITH BOSS

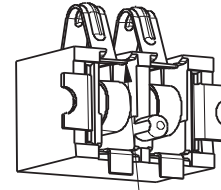
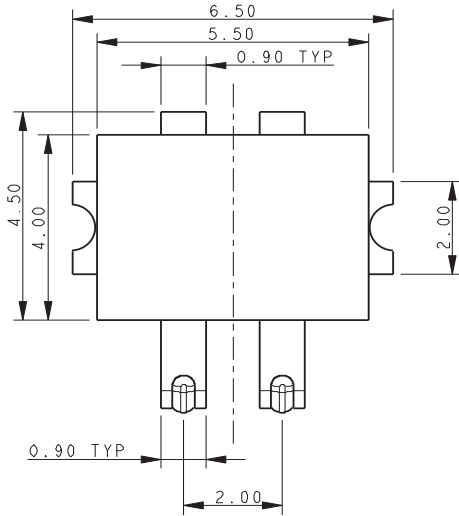

CONTACT NOSE RETAINED
ANTI-SNAG FEATURE

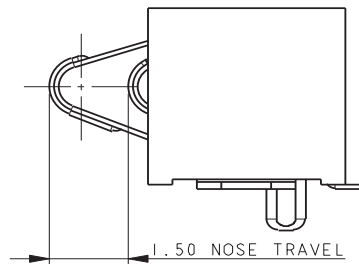

DEFLECTED CONNECTOR

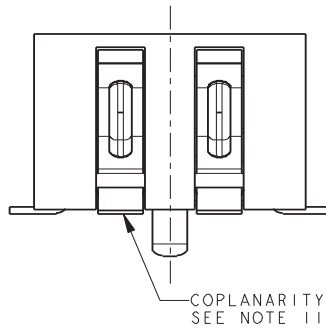

COPLANARITY
SEE NOTE 11

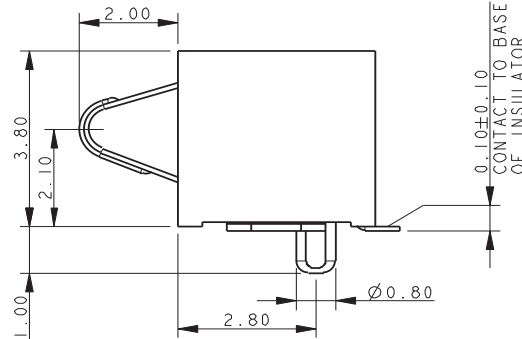

UNDEFLECTED CONTACT

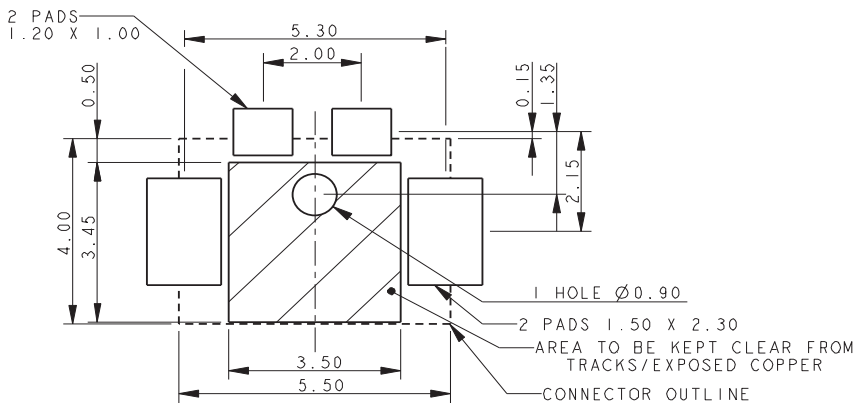

SUGGESTED PCB LAYOUT

NOTES:

1. GENERAL TOLERANCE ± 0.20 UNLESS OTHERWISE STATED.
2. FOR FULL PRODUCT SPECIFICATION REFER TO AVX SPEC 201-01-203.
3. FOR MATING PAD DETAILS REFER TO PAGE 13.
4. PACKING DETAILS ON PAGE 12.
5. INSULATOR MATERIAL: GLASS FILLED NYLON 46, UL94 V-0, COLOR BLACK.
6. CONTACT MATERIAL: BERYLLIUM COPPER.
7. CONTACT PLATING; SELECTIVE GOLD OVER NICKEL, PURE TIN ON TAILS.
8. BRACKET MATERIAL; PHOSPHOR BRONZE.
9. BRACKET PLATING; PURE TIN OVER NICKEL.
10. NOMINAL CONTACT FORCE 90 GRAMS AT 1.50 DEFLECTION.
11. COPLANARITY OF ALL CONTACT TAILS AND PADS 0.10MM MAXIMUM.

Right Angle 2.0mm Pitch Connector

9155-700



3 WAY BATTERY CONNECTOR – RIGHT ANGLE 2MM PITCH – WITHOUT BOSS

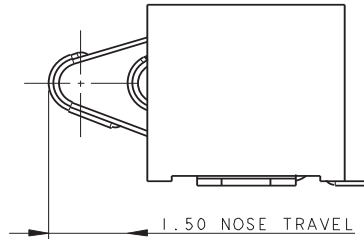
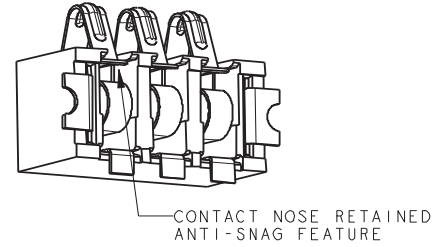
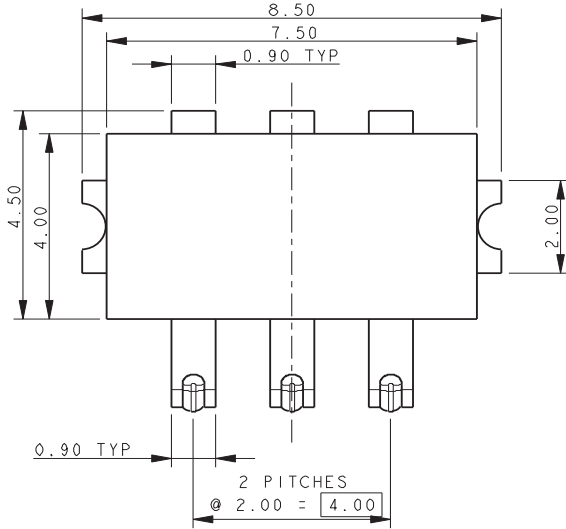

DEFLECTED CONNECTOR

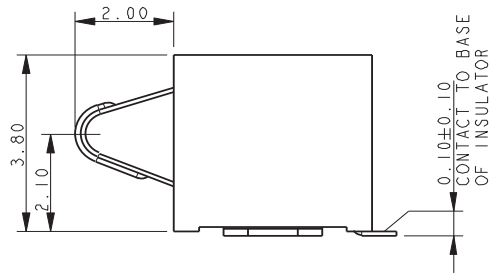
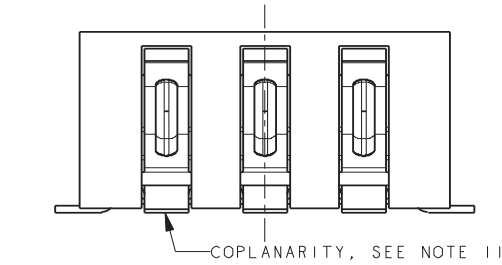

UNDEFLECTED CONTACT

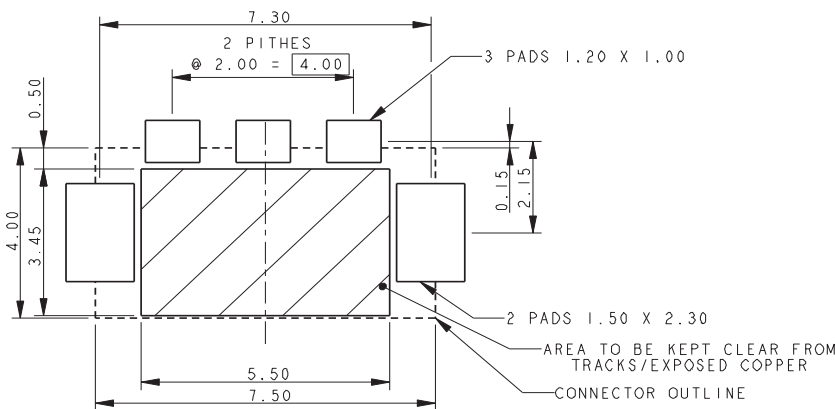

SUGGESTED PCB LAYOUT

NOTES:

1. GENERAL TOLERANCE ± 0.20 UNLESS OTHERWISE STATED.
2. FOR FULL PRODUCT SPECIFICATION REFER TO AVX SPEC 201-01-203.
3. FOR MATING PAD DETAILS REFER TO PAGE 13.
4. PACKING DETAILS ON PAGE 12.
5. INSULATOR MATERIAL: GLASS FILLED NYLON 46, UL94 V-0, COLOR BLACK.
6. CONTACT MATERIAL: BERYLLIUM COPPER.
7. CONTACT PLATING; SELECTIVE GOLD OVER NICKEL, PURE TIN ON TAILS.
8. BRACKET MATERIAL; PHOSPHOR BRONZE.
9. BRACKET PLATING; PURE TIN OVER NICKEL.
10. NOMINAL CONTACT FORCE 90 GRAMS AT 1.50 DEFLECTION.
11. COPLANARITY OF ALL CONTACT TAILS AND PADS 0.10MM MAXIMUM.

Right Angle 2.0mm Pitch Connector

9155-700



3 WAY BATTERY CONNECTOR – RIGHT ANGLE 2MM PITCH – WITH BOSS

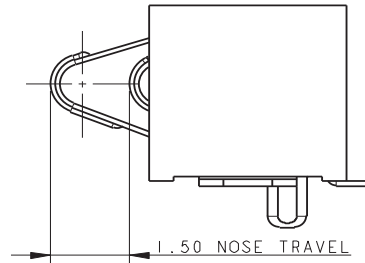
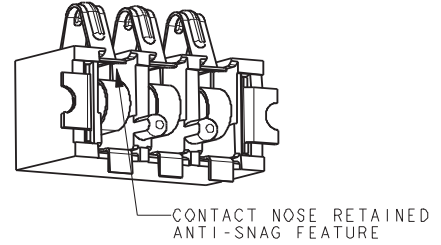
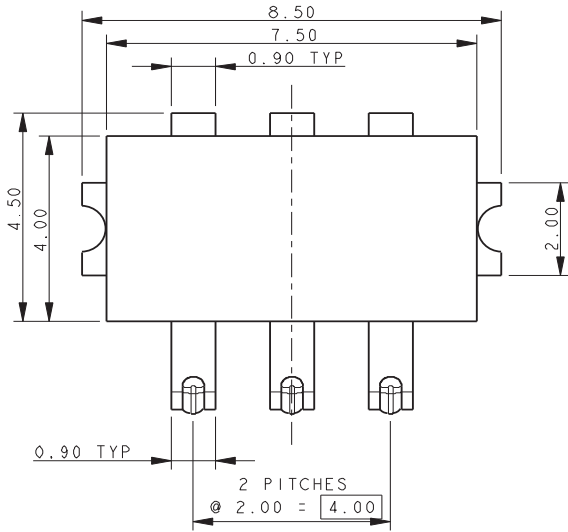

DEFLECTED CONNECTOR

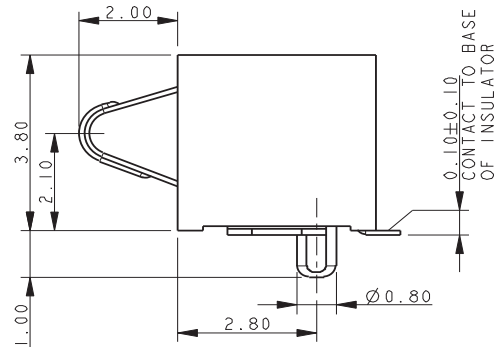
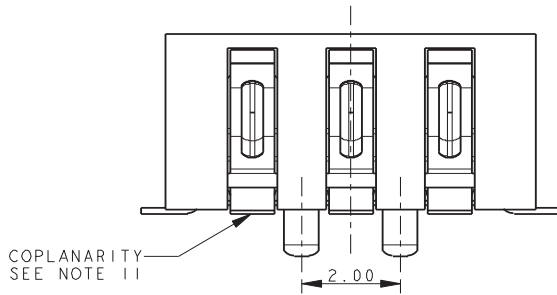

UNDEFLECTED CONTACT

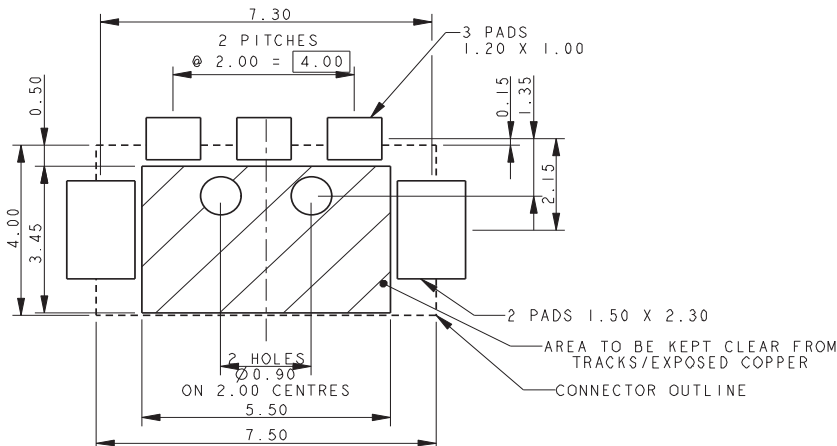

SUGGESTED PCB LAYOUT

NOTES:

1. GENERAL TOLERANCE ± 0.20 UNLESS OTHERWISE STATED.
2. FOR FULL PRODUCT SPECIFICATION REFER TO AVX SPEC 201-01-203.
3. FOR MATING PAD DETAILS REFER TO PAGE 13.
4. PACKING DETAILS ON PAGE 12.
5. INSULATOR MATERIAL: GLASS FILLED NYLON 46, UL94 V-0, COLOR BLACK.
6. CONTACT MATERIAL: BERYLLIUM COPPER.
7. CONTACT PLATING; SELECTIVE GOLD OVER NICKEL, PURE TIN ON TAILS.
8. BRACKET MATERIAL; PHOSPHOR BRONZE.
9. BRACKET PLATING; PURE TIN OVER NICKEL.
10. NOMINAL CONTACT FORCE 90 GRAMS AT 1.50 DEFLECTION.
11. COPLANARITY OF ALL CONTACT TAILS AND PADS 0.10MM MAXIMUM.

Right Angle 2.0mm Pitch Connector

9155-700

4 WAY BATTERY CONNECTOR – RIGHT ANGLE 2MM PITCH – WITHOUT BOSS

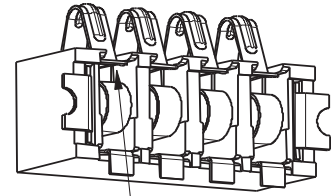
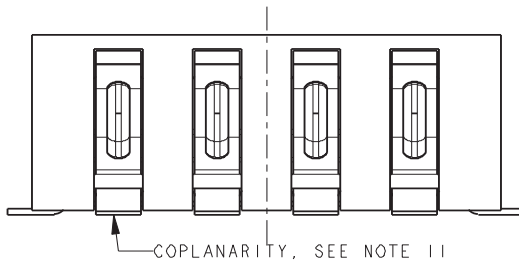
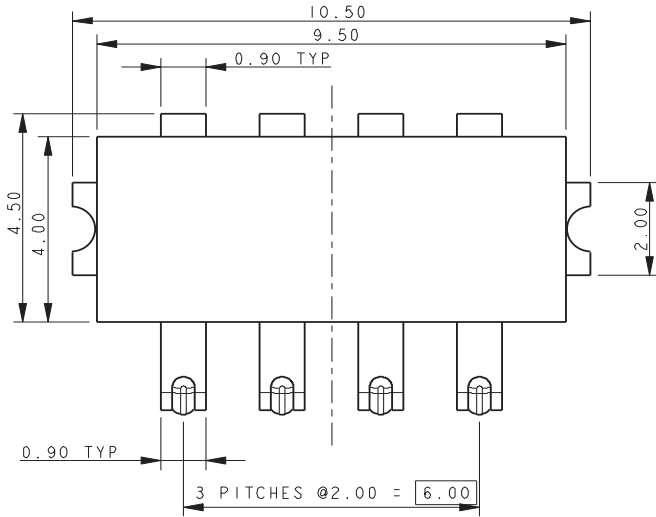

CONTACT NOSE RETAINED
ANTI-SNAG FEATURE

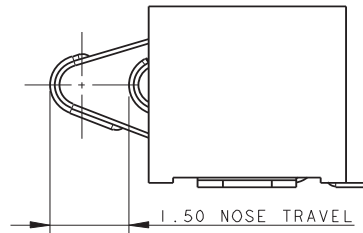

DEFLECTED CONNECTOR

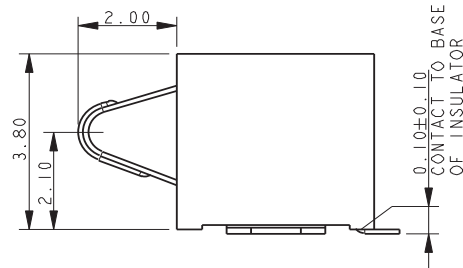

UNDEFLECTED CONTACT

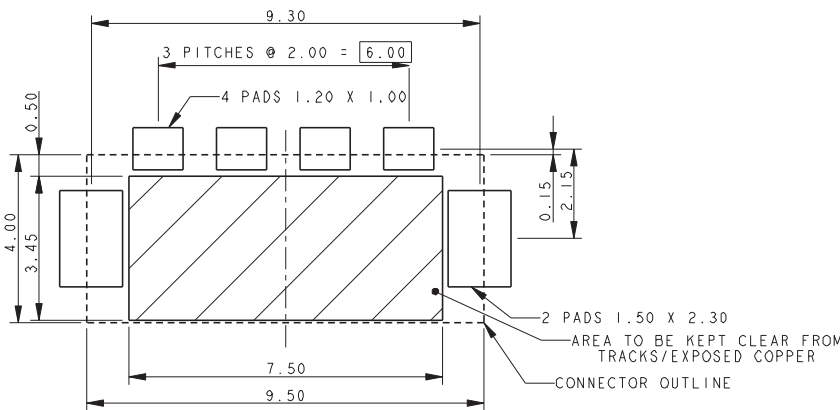

SUGGESTED PCB LAYOUT

NOTES:

1. GENERAL TOLERANCE ± 0.20 UNLESS OTHERWISE STATED.
2. FOR FULL PRODUCT SPECIFICATION REFER TO AVX SPEC 201-01-203.
3. FOR MATING PAD DETAILS REFER TO PAGE 13.
4. PACKING DETAILS ON PAGE 12.
5. INSULATOR MATERIAL: GLASS FILLED NYLON 46, UL94 V-0, COLOR BLACK.
6. CONTACT MATERIAL: BERYLLIUM COPPER.
7. CONTACT PLATING; SELECTIVE GOLD OVER NICKEL, PURE TIN ON TAILS.
8. BRACKET MATERIAL; PHOSPHOR BRONZE.
9. BRACKET PLATING; PURE TIN OVER NICKEL.
10. NOMINAL CONTACT FORCE 90 GRAMS AT 1.50 DEFLECTION.
11. COPLANARITY OF ALL CONTACT TAILS AND PADS 0.10MM MAXIMUM.

Right Angle 2.0mm Pitch Connector

9155-700

4 WAY BATTERY CONNECTOR – RIGHT ANGLE 2MM PITCH – WITH BOSS

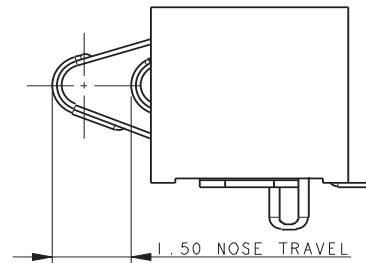
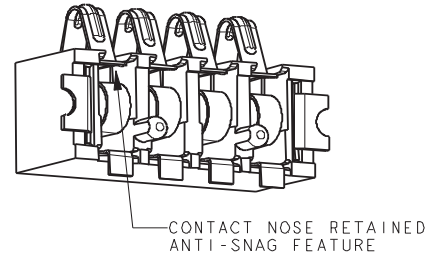
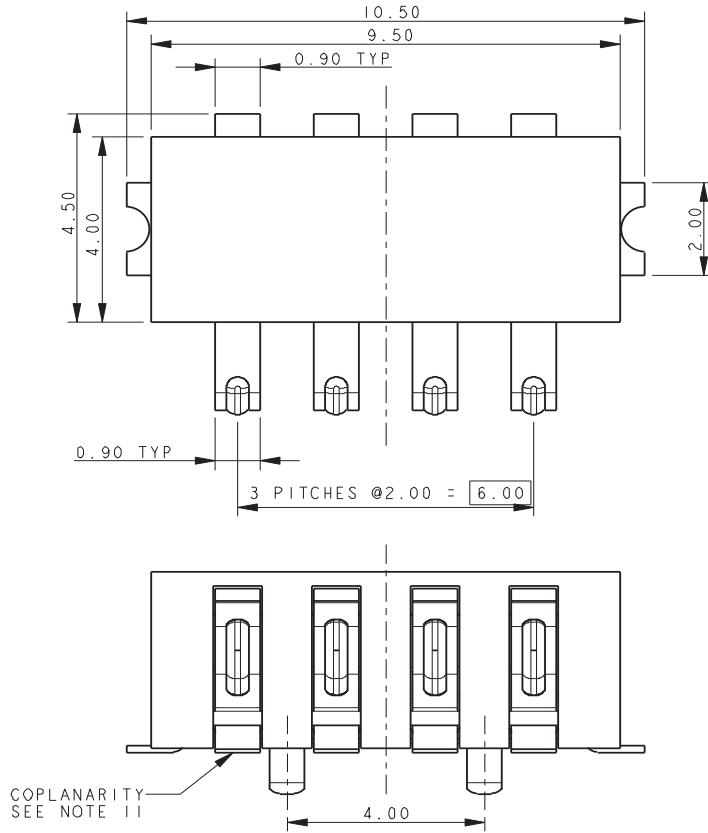

DEFLECTED CONNECTOR

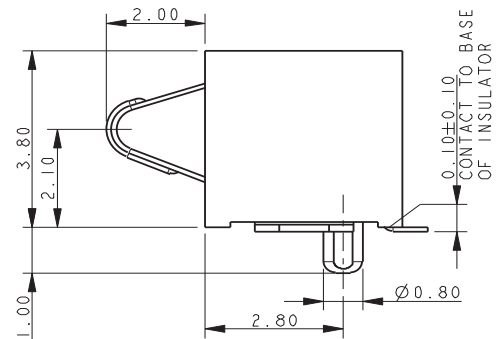

UNDEFLECTED CONTACT

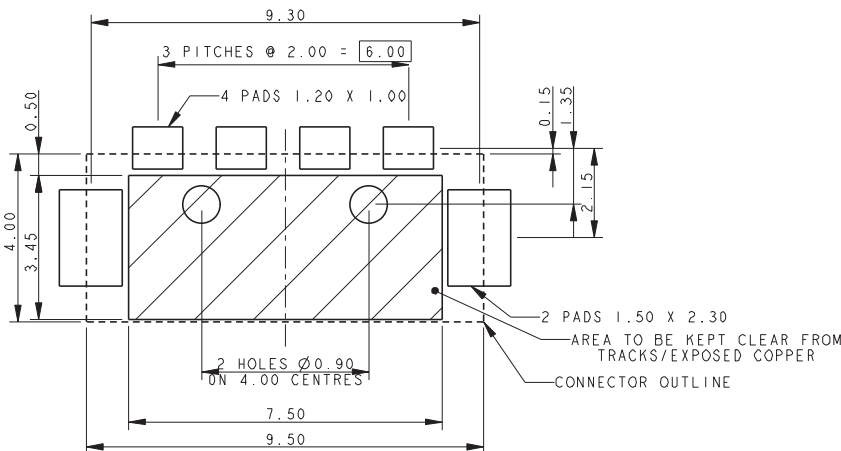

SUGGESTED PCB LAYOUT

NOTES:

1. GENERAL TOLERANCE ± 0.20 UNLESS OTHERWISE STATED.
2. FOR FULL PRODUCT SPECIFICATION REFER TO AVX SPEC 201-01-203.
3. FOR MATING PAD DETAILS REFER TO PAGE 13.
4. PACKING DETAILS ON PAGE 12.
5. INSULATOR MATERIAL: GLASS FILLED NYLON 46, UL94 V-0, COLOR BLACK.
6. CONTACT MATERIAL: BERYLLIUM COPPER.
7. CONTACT PLATING; SELECTIVE GOLD OVER NICKEL, PURE TIN ON TAILS.
8. BRACKET MATERIAL; PHOSPHOR BRONZE.
9. BRACKET PLATING; PURE TIN OVER NICKEL.
10. NOMINAL CONTACT FORCE 90 GRAMS AT 1.50 DEFLECTION.
11. COPLANARITY OF ALL CONTACT TAILS AND PADS 0.10MM MAXIMUM.

Right Angle 2.0mm Pitch Connector

9155-700



5 WAY BATTERY CONNECTOR – RIGHT ANGLE 2MM PITCH – WITHOUT BOSS

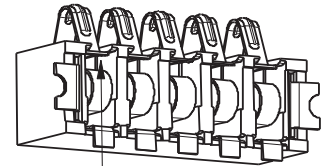
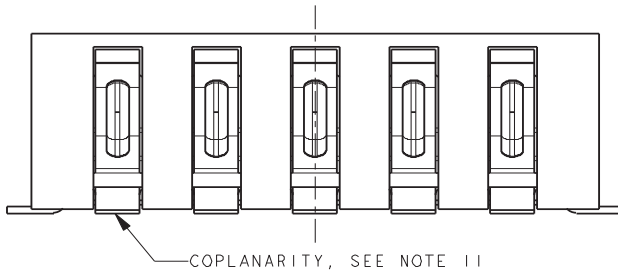
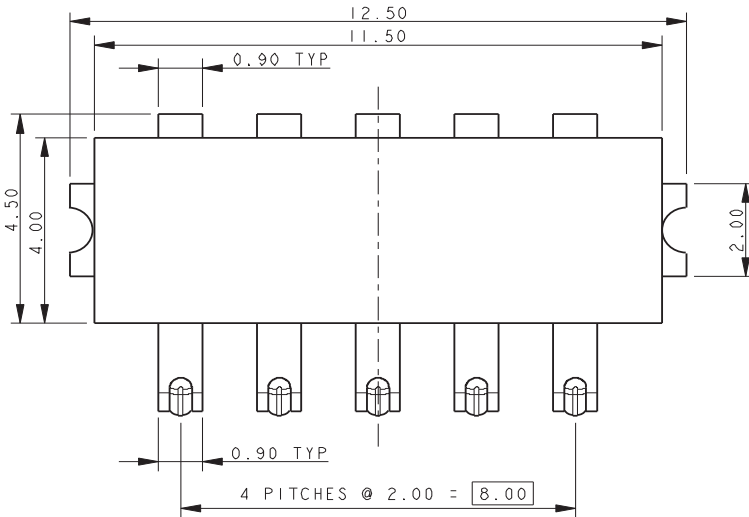

CONTACT NOSE RETAINED
ANTI-SNAG FEATURE

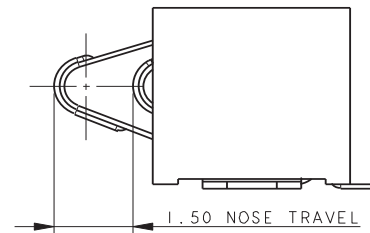

DEFLECTED CONNECTOR

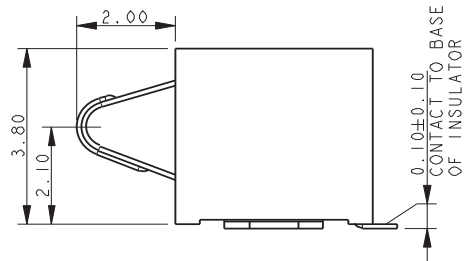

UNDEFLECTED CONTACT

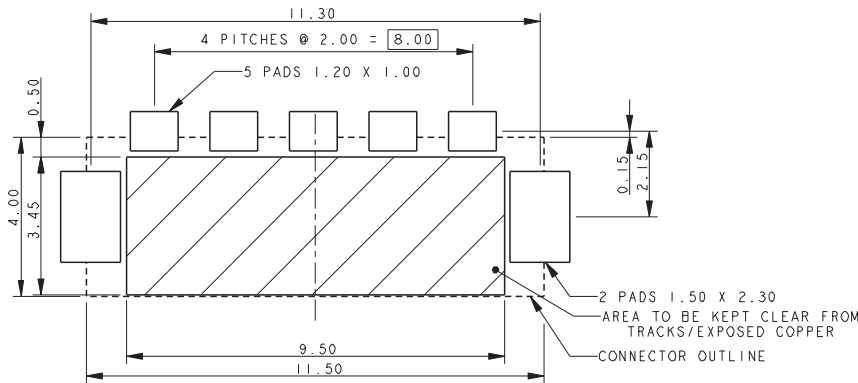

SUGGESTED PCB LAYOUT

NOTES:

1. GENERAL TOLERANCE ± 0.20 UNLESS OTHERWISE STATED.
2. FOR FULL PRODUCT SPECIFICATION REFER TO AVX SPEC 201-01-203.
3. FOR MATING PAD DETAILS REFER TO PAGE 13.
4. PACKING DETAILS ON PAGE 12.
5. INSULATOR MATERIAL: GLASS FILLED NYLON 46, UL94 V-0, COLOR BLACK.
6. CONTACT MATERIAL: BERYLLIUM COPPER.
7. CONTACT PLATING; SELECTIVE GOLD OVER NICKEL, PURE TIN ON TAILS.
8. BRACKET MATERIAL; PHOSPHOR BRONZE.
9. BRACKET PLATING; PURE TIN OVER NICKEL.
10. NOMINAL CONTACT FORCE 90 GRAMS AT 1.50 DEFLECTION.
11. COPLANARITY OF ALL CONTACT TAILS AND PADS 0.12MM MAXIMUM.

Right Angle 2.0mm Pitch Connector

9155-700

5 WAY BATTERY CONNECTOR – RIGHT ANGLE 2MM PITCH – WITH BOSS

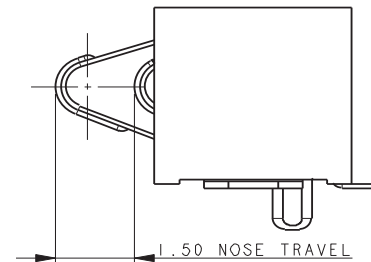
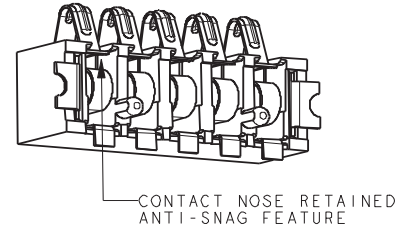
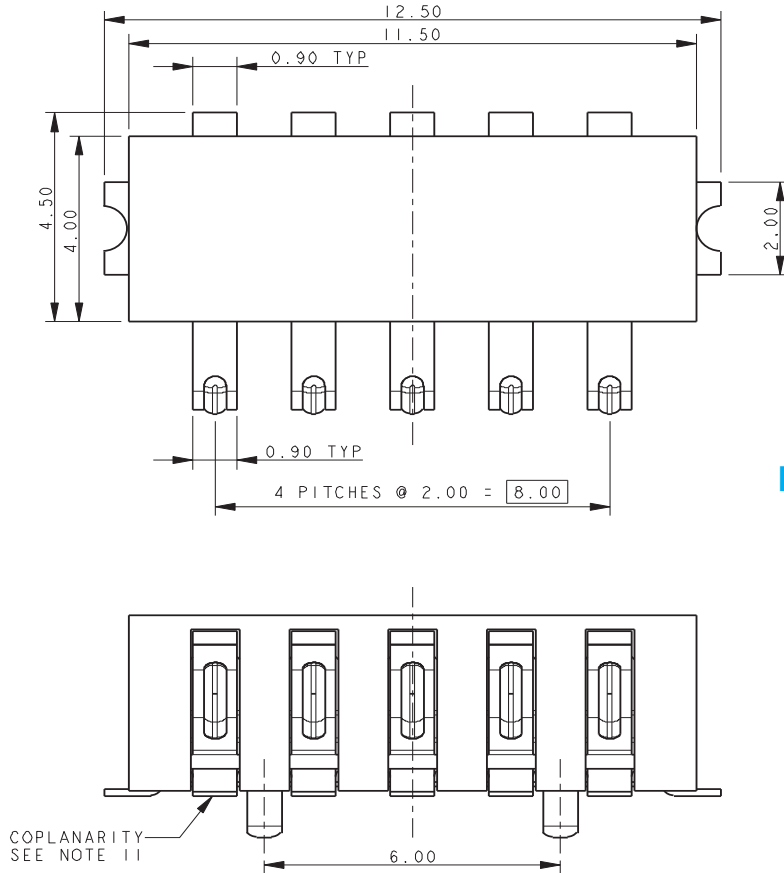

DEFLECTED CONNECTOR

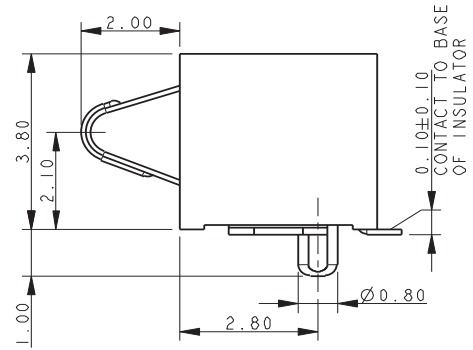

UNDEFLECTED CONTACT

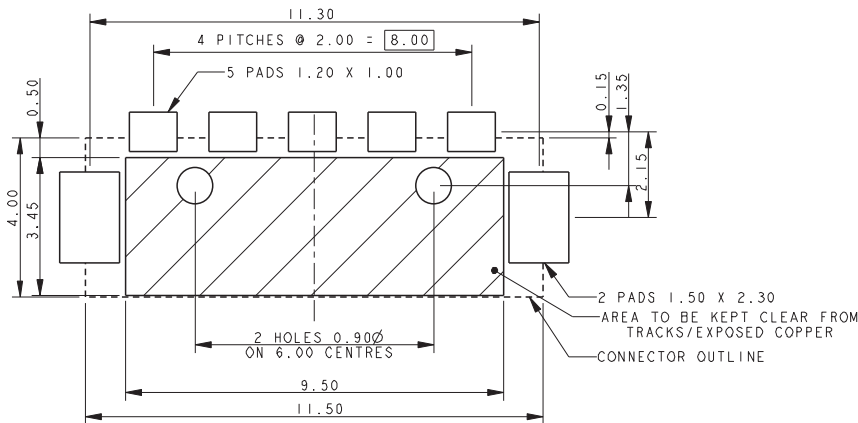

SUGGESTED PCB LAYOUT

NOTES:

1. GENERAL TOLERANCE ± 0.20 UNLESS OTHERWISE STATED.
2. FOR FULL PRODUCT SPECIFICATION REFER TO AVX SPEC 201-01-203.
3. FOR MATING PAD DETAILS REFER TO PAGE 13.
4. PACKING DETAILS ON PAGE 12.
5. INSULATOR MATERIAL: GLASS FILLED NYLON 46, UL94 V-0, COLOR BLACK.
6. CONTACT MATERIAL: BERYLLIUM COPPER.
7. CONTACT PLATING; SELECTIVE GOLD OVER NICKEL, PURE TIN ON TAILS.
8. BRACKET MATERIAL; PHOSPHOR BRONZE.
9. BRACKET PLATING; PURE TIN OVER NICKEL.
10. NOMINAL CONTACT FORCE 90 GRAMS AT 1.50 DEFLECTION.
11. COPLANARITY OF ALL CONTACT TAILS AND PADS 0.12MM MAXIMUM.

Right Angle 2.0mm Pitch Connector

9155-700

6 WAY BATTERY CONNECTOR – RIGHT ANGLE 2MM PITCH – WITHOUT BOSS

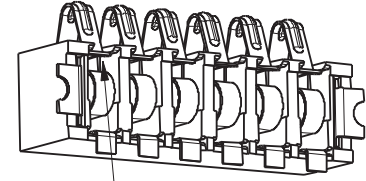
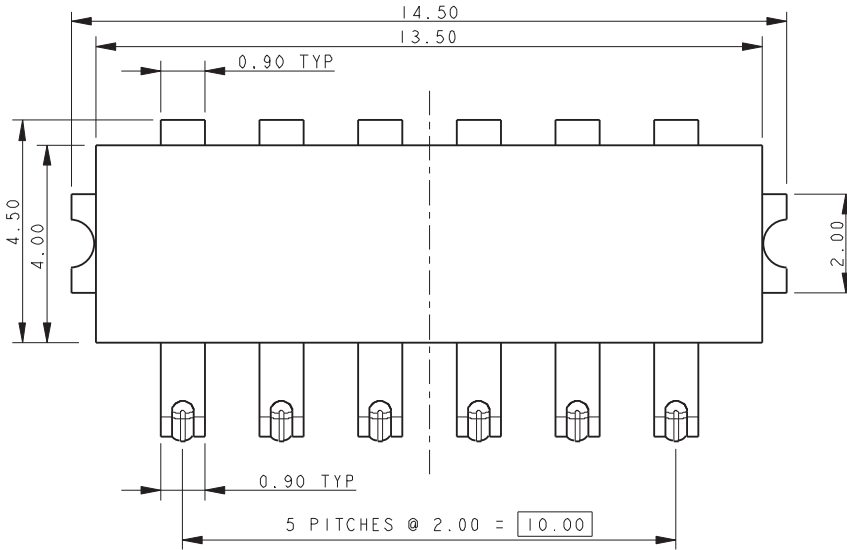

CONTACT NOSE RETAINED ANTI-SNAG FEATURE

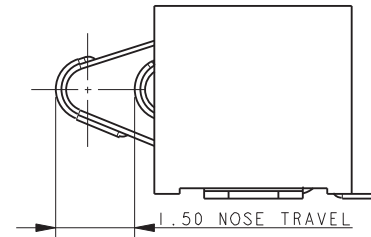

DEFLECTED CONNECTOR

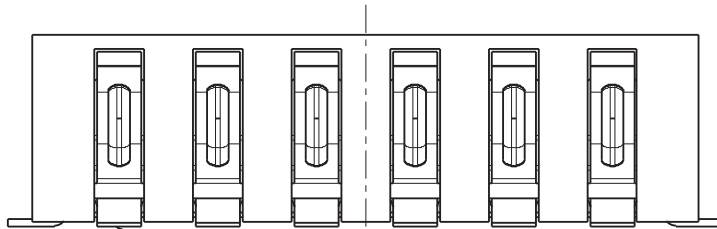

COPLANARITY SEE NOTE 11

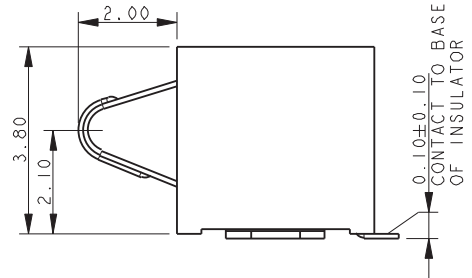

UNDEFLECTED CONTACT

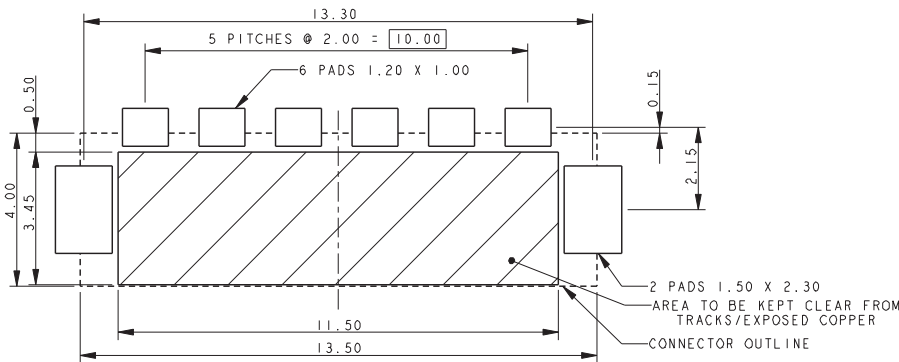

SUGGESTED PCB LAYOUT

NOTES:

1. GENERAL TOLERANCE ± 0.20 UNLESS OTHERWISE STATED.
2. FOR FULL PRODUCT SPECIFICATION REFER TO AVX SPEC 201-01-203.
3. FOR MATING PAD DETAILS REFER TO PAGE 13.
4. PACKING DETAILS ON PAGE 12.
5. INSULATOR MATERIAL: GLASS FILLED NYLON 46, UL94 V-0, COLOR BLACK.
6. CONTACT MATERIAL: BERYLLIUM COPPER.
7. CONTACT PLATING; SELECTIVE GOLD OVER NICKEL, PURE TIN ON TAILS.
8. BRACKET MATERIAL; PHOSPHOR BRONZE.
9. BRACKET PLATING; PURE TIN OVER NICKEL.
10. NOMINAL CONTACT FORCE 90 GRAMS AT 1.50 DEFLECTION.
11. COPLANARITY OF ALL CONTACT TAILS AND PADS 0.12MM MAXIMUM.

Right Angle 2.0mm Pitch Connector

9155-700

6 WAY BATTERY CONNECTOR – RIGHT ANGLE 2MM PITCH – WITH BOSS

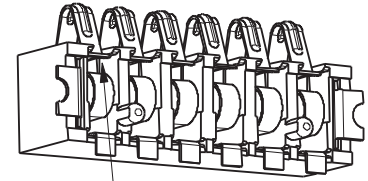
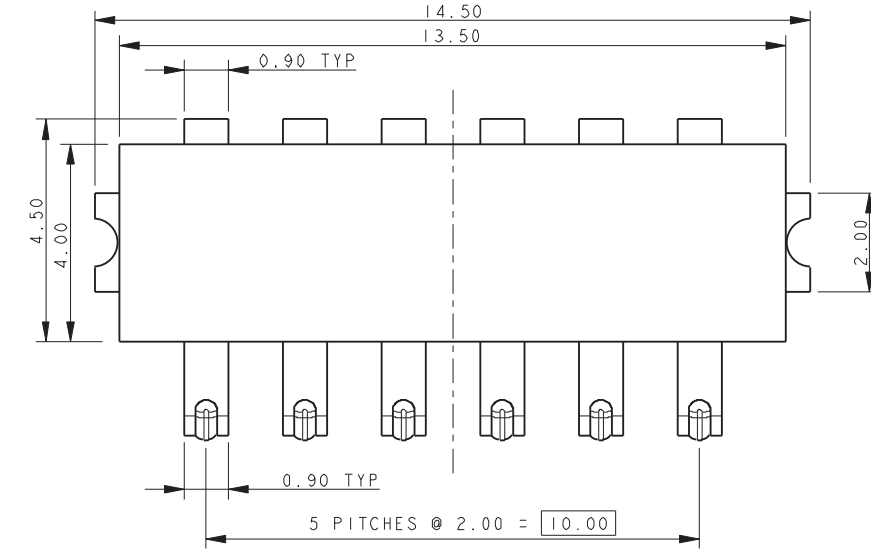

CONTACT NOSE RETAINED
ANTI-SNAG FEATURE

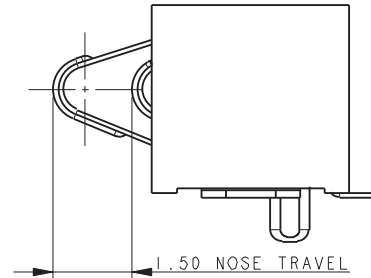

DEFLECTED CONNECTOR

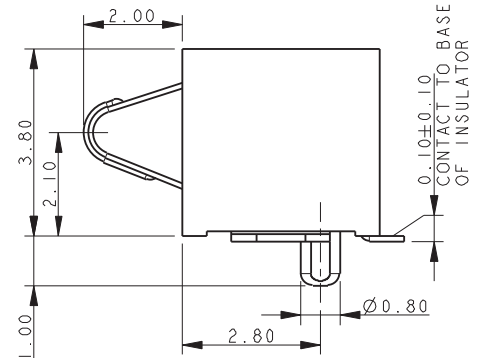
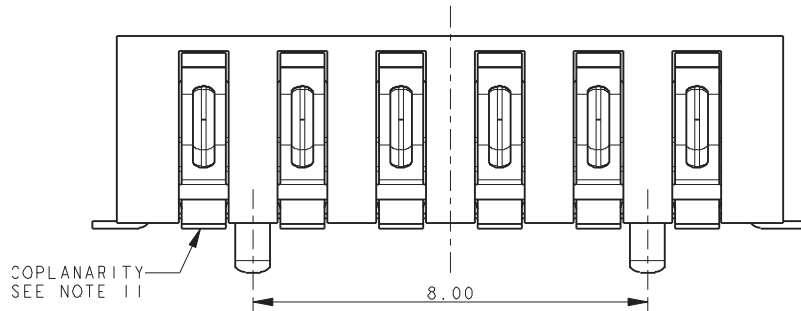

UNDEFLECTED CONTACT

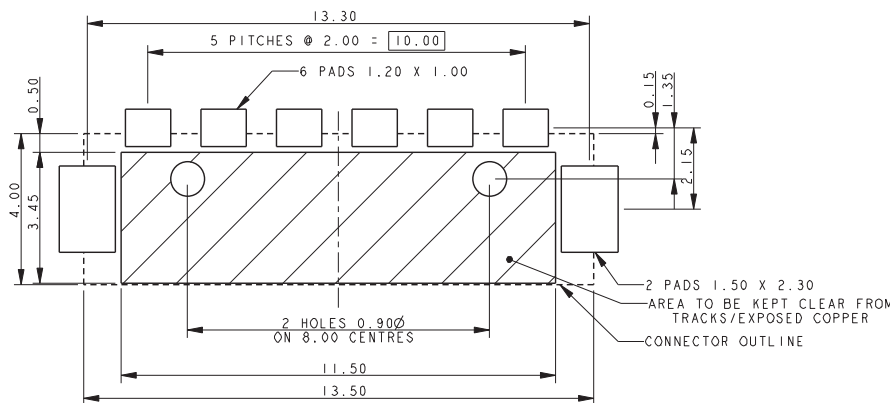

SUGGESTED PCB LAYOUT

NOTES:

1. GENERAL TOLERANCE ± 0.20 UNLESS OTHERWISE STATED.
2. FOR FULL PRODUCT SPECIFICATION REFER TO AVX SPEC 201-01-203.
3. FOR MATING PAD DETAILS REFER TO PAGE 13.
4. PACKING DETAILS ON PAGE 12.
5. INSULATOR MATERIAL: GLASS FILLED NYLON 46, UL94 V-0, COLOR BLACK.
6. CONTACT MATERIAL: BERYLLIUM COPPER.
7. CONTACT PLATING; SELECTIVE GOLD OVER NICKEL, PURE TIN ON TAILS.
8. BRACKET MATERIAL; PHOSPHOR BRONZE.
9. BRACKET PLATING; PURE TIN OVER NICKEL.
10. NOMINAL CONTACT FORCE 90 GRAMS AT 1.50 DEFLECTION.
11. COPLANARITY OF ALL CONTACT TAILS AND PADS 0.12MM MAXIMUM.

Right Angle 2.0mm Pitch Connector

9155-700

PACKING DETAILS

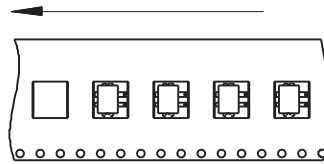
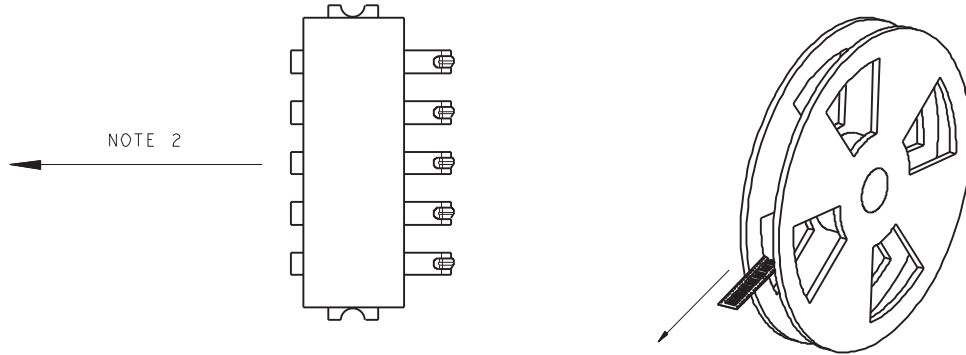

No of Ways	2
REEL QTY	1000 without Boss 1000 with Boss
TAPE WIDTH	24mm
POCKET PITCH	12mm

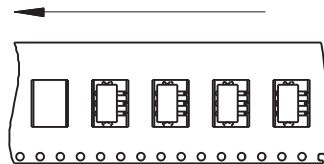

No of Ways	3
REEL QTY	1000 without Boss 1000 with Boss
TAPE WIDTH	24mm
POCKET PITCH	12mm

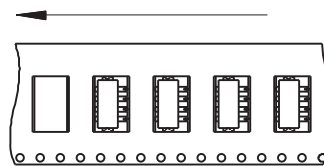

No of Ways	4
REEL QTY	1000 without Boss 1000 with Boss
TAPE WIDTH	24mm
POCKET PITCH	12mm

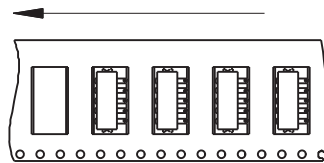

No of Ways	5
REEL QTY	1000 without Boss 1000 with Boss
TAPE WIDTH	24mm
POCKET PITCH	12mm

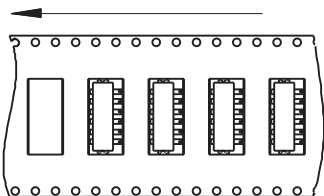

No of Ways	6
REEL QTY	1000 without Boss 1000 with Boss
TAPE WIDTH	32mm
POCKET PITCH	12mm

- NOTES:
1. PARTS TO BE PACKED ON 330MM REELS.
2. COMPONENT ORIENTATION SHOWN.

2MM PITCH RIGHT ANGLE – MATING PADS

2 WAY – MATING PADS

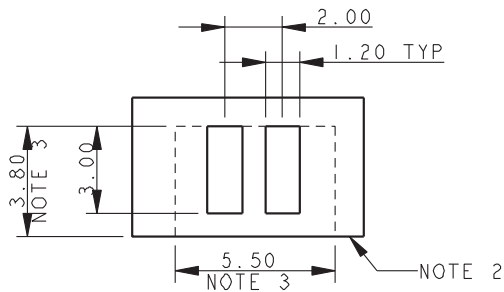

3 WAY – MATING PADS

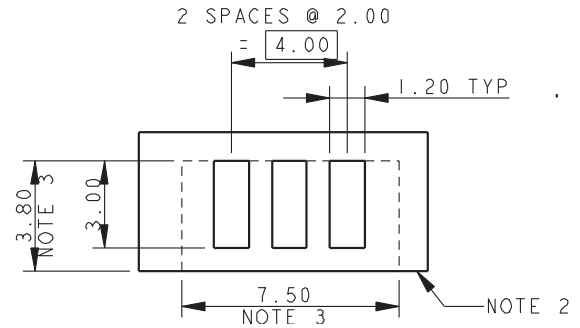

4 WAY – MATING PADS

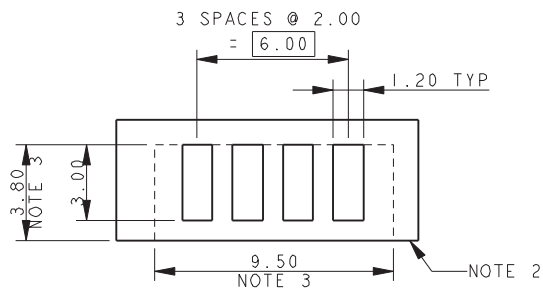

5 WAY – MATING PADS

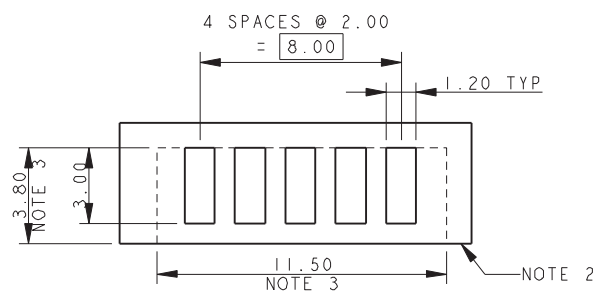

6 WAY – MATING PADS

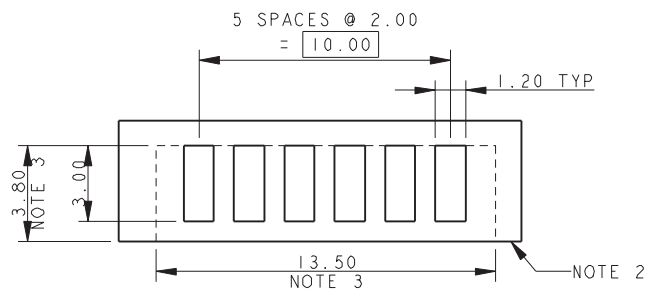

NOTES:

1. SUGGESTED MATING PADS FOR RIGHT ANGLE BATTERY CONNECTORS.
2. TOP SURFACE OF HORIZONTAL PCB/BASE OF CONNECTOR.
3. PREFERRED PLATING ON PADS, GOLD OVER NICKEL.



Компания «ЭлектроПласт» предлагает заключение долгосрочных отношений при поставках импортных электронных компонентов на взаимовыгодных условиях!

Наши преимущества:

- Оперативные поставки широкого спектра электронных компонентов отечественного и импортного производства напрямую от производителей и с крупнейших мировых складов;
- Поставка более 17-ти миллионов наименований электронных компонентов;
- Поставка сложных, дефицитных, либо снятых с производства позиций;
- Оперативные сроки поставки под заказ (от 5 рабочих дней);
- Экспресс доставка в любую точку России;
- Техническая поддержка проекта, помощь в подборе аналогов, поставка прототипов;
- Система менеджмента качества сертифицирована по Международному стандарту ISO 9001;
- Лицензия ФСБ на осуществление работ с использованием сведений, составляющих государственную тайну;
- Поставка специализированных компонентов (Xilinx, Altera, Analog Devices, Intersil, Interpoint, Microsemi, Aeroflex, Peregrine, Syfer, Eurofarad, Texas Instrument, Miteq, Cobham, E2V, MA-COM, Hittite, Mini-Circuits, General Dynamics и др.);

Помимо этого, одним из направлений компании «ЭлектроПласт» является направление «Источники питания». Мы предлагаем Вам помощь Конструкторского отдела:

- Подбор оптимального решения, техническое обоснование при выборе компонента;
- Подбор аналогов;
- Консультации по применению компонента;
- Поставка образцов и прототипов;
- Техническая поддержка проекта;
- Защита от снятия компонента с производства.



Как с нами связаться

Телефон: 8 (812) 309 58 32 (многоканальный)

Факс: 8 (812) 320-02-42

Электронная почта: org@eplast1.ru

Адрес: 198099, г. Санкт-Петербург, ул. Калинина, дом 2, корпус 4, литера А.