





Features

- Small footprint size (0805) and low profile for space-constrained mobile applications
- Ultra-low resistance
- Symmetrical design
- Surface mount packaging for automated assembly
- RoHS compliant* and halogen free**
- Agency recognition:  

Applications

- USB port protection - USB 2.0, 3.0 & OTG
- HDMI 1.4 Source protection
- PC motherboards - Plug & Play protection
- Mobile phones - Battery & port protection
- PDAs / digital cameras
- Bluetooth® earphone power protection
- Game console port protection

MF-PSML Series - Low Ohmic PTC Resettable Fuses

Electrical Characteristics

Model	V max. Volts	I max. Amps	I _{hold}	I _{trip}	Resistance		Max. Time To Trip		Tripped Power Dissipation
			Amperes at 23 °C		Ohms at 23 °C		Amperes at 23 °C	Seconds at 23 °C	Watts at 23 °C
			Hold	Trip	R _{Min.}	R _{1Max.}			Typ.
MF-PSML110	6	50	1.10	1.80	0.0175	0.130	8.00	0.3	0.6
MF-PSML150	6	50	1.50	3.00	0.015	0.065	8.00	0.5	0.6
MF-PSML175	6	50	1.75	3.50	0.005	0.055	8.00	0.6	0.6
MF-PSML200	6	50	2.00	4.00	0.005	0.045	8.00	1.0	0.6
MF-PSML260	6	50	2.60	5.00	0.003	0.035	8.00	4.0	0.6
MF-PSML300	6	50	3.00	6.00	0.003	0.030	8.00	5.0	0.6
MF-PSML350***	6	50	3.50	7.00	0.003	0.025	8.00	5.0	0.6

*** TÜV approval pending.

Environmental Characteristics

Operating Temperature.....	-40 °C to +85 °C	
Passive Aging.....	+85 °C, 1000 hours.....	±10 % typical resistance change
Humidity Aging.....	+85 °C, 85 % R.H. 100 hours.....	±15 % typical resistance change
Thermal Shock.....	+85 °C to -40 °C, 20 times.....	±30 % typical resistance change
Solvent Resistance.....	MIL-STD-202, Method 215.....	No change
Vibration.....	MIL-STD-883C, Method 2007.1, Condition A.....	No change
Moisture Sensitivity Level (MSL).....	Level 1.....	
ESD Classification - HBM.....	Class 6.....	

Test Procedures And Requirements For Model MF-PSML Series

Test	Test Conditions	Accept/Reject Criteria
Visual/Mech.....	Verify dimensions and materials.....	Per MF physical description
Resistance.....	In still air @ 23 °C.....	R _{min} ≤ R ≤ R _{1max}
Time to Trip.....	At specified current, V _{max} , 23 °C.....	T ≤ max. time to trip (seconds)
Hold Current.....	30 min. at I _{hold}	No trip
Trip Cycle Life.....	V _{max} , I _{max} , 100 cycles.....	No arcing or burning
Trip Endurance.....	V _{max} , 48 hours.....	No arcing or burning
Solderability.....	ANSI/J-STD-002.....	95 % min. coverage
UL File Number.....	E174545 http://www.ul.com/ Follow link to Certifications, then UL File No., enter E174545	
TÜV Certificate Number.....	R 50171531 http://www.tuvdotcom.com/ Follow link to "other certificates", enter File No. 50171531	

* RoHS Directive 2002/95/EC Jan. 27, 2003 including annex and RoHS Recast 2011/65/EU June 8, 2011.

**Bourns considers a product to be "halogen free" if (a) the Bromine (Br) content is 900 ppm or less; (b) the Chlorine (Cl) content is 900 ppm or less; and (c) the total Bromine (Br) and Chlorine (Cl) content is 1500 ppm or less.

Specifications are subject to change without notice.

The device characteristics and parameters in this data sheet can and do vary in different applications and actual device performance may vary over time. Users should verify actual device performance in their specific applications.

MF-PSML Series - Low Ohmic PTC Resettable Fuses

BOURNS®

Product Dimensions

Model	A		B		C		D
	Min.	Max.	Min.	Max.	Min.	Max.	Min.
MF-PSML110	$\frac{2.00}{(0.079)}$	$\frac{2.30}{(0.091)}$	$\frac{1.20}{(0.047)}$	$\frac{1.50}{(0.059)}$	$\frac{0.30}{(0.012)}$	$\frac{0.60}{(0.024)}$	$\frac{0.20}{(0.008)}$
MF-PSML150							
MF-PSML175							
MF-PSML200							
MF-PSML260	$\frac{2.00}{(0.079)}$	$\frac{2.30}{(0.091)}$	$\frac{1.20}{(0.047)}$	$\frac{1.50}{(0.059)}$	$\frac{0.45}{(0.018)}$	$\frac{0.80}{(0.031)}$	$\frac{0.20}{(0.008)}$
MF-PSML300							
MF-PSML350							

Packaging:

MF-PSML110~MF-PSML200 = 6000 pcs. per reel
 MF-PSML260~MF-PSML350 = 4500 pcs. per reel

DIMENSIONS: $\frac{\text{MM}}{(\text{INCHES})}$

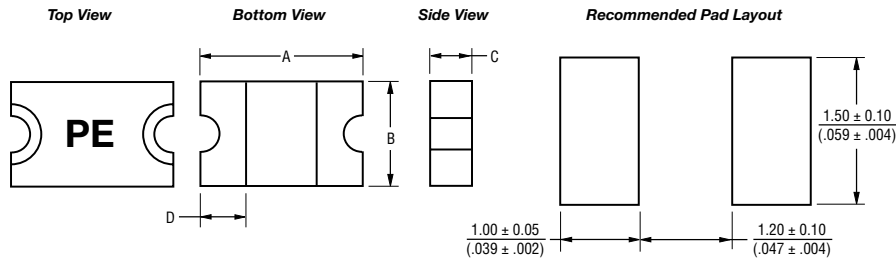

Terminal material:
 Nickel/gold plated.

Termination pad solderability:
 Standard Au finish:
 Meets ANSI/J-STD-002 Category 2.

Recommended Storage:
 40 °C max./70 % RH max.

Thermal Derating Chart - I_{hold} (Amps)

Model	Ambient Operating Temperature								
	-40 °C	-20 °C	0 °C	23 °C	40 °C	50 °C	60 °C	70 °C	85 °C
MF-PSML110	1.93	1.65	1.37	1.10	0.83	0.69	0.55	0.41	0.31
MF-PSML150	2.37	2.07	1.80	1.50	1.25	1.08	0.93	0.74	0.50
MF-PSML175	2.57	2.33	2.07	1.75	1.49	1.36	1.24	1.00	0.91
MF-PSML200	2.94	2.66	2.36	2.00	1.70	1.55	1.42	1.14	1.04
MF-PSML260	3.82	3.46	3.07	2.60	2.21	2.02	1.85	1.48	1.35
MF-PSML300	4.41	3.99	3.54	3.00	2.55	2.33	2.13	1.71	1.56
MF-PSML350	5.51	4.66	4.13	3.50	2.98	2.71	2.49	2.00	1.82

Specifications are subject to change without notice.

The device characteristics and parameters in this data sheet can and do vary in different applications and actual device performance may vary over time. Users should verify actual device performance in their specific applications.

MF-PSML Series - Low Ohmic PTC Resettable Fuses



Solder Reflow Recommendations

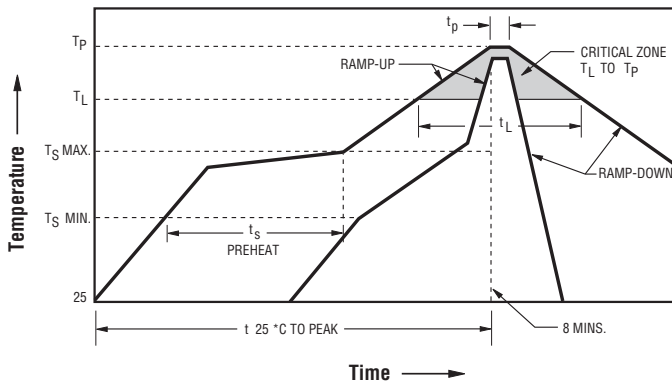

Notes:

- MF-PSML models cannot be wave soldered or hand soldered. Please contact Bourns for soldering recommendations.
- All temperatures refer to topside of the package, measured on the package body surface.
- If reflow temperatures exceed the recommended profile, devices may not meet the published specifications.
- Compatible with Pb and Pb-free solder reflow profiles.
- Excess solder may cause a short circuit, especially during hand soldering. Please refer to the Multifuse® Polymer PTC Soldering Recommendation guidelines.
- Designed for single solder reflow operations.

Profile Feature	Pb-Free Assembly
Average Ramp-Up Rate ($T_{S_{max}}$ to T_P)	3 °C / second max.
PREHEAT: Temperature Min. ($T_{S_{min}}$) Temperature Max. ($T_{S_{max}}$) Time ($t_{s_{min}}$ to $t_{s_{max}}$)	150 °C 200 °C 60~180 seconds
TIME MAINTAINED ABOVE: Temperature (T_L) Time (t_L)	217 °C 60~150 seconds
Peak / Classification Temperature (T_P)	260 °C
Time within 5 °C of Actual Peak Temperature (t_p)	20~40 seconds
Ramp-Down Rate	6 °C / second max.
Time within 25 °C to Peak Temperature	8 minutes max.

How to Order

MF - PSML 110 - 2

Multifuse® Product Designator _____
 Series _____
 PSML = 0805 Surface Mount Component
 Hold Current, I_{hold} _____
 110 - 350 (1.10 Amps - 3.50 Amps)
 Packaging _____
 Packaged per EIA 481-1
 -2 = Tape and Reel

Typical Part Marking

Represents total content. Layout may vary.

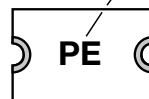

PART IDENTIFICATION:

MF-PSML110 = PE
 MF-PSML150 = PG
 MF-PSML175 = PH
 MF-PSML200 = PJ
 MF-PSML260 = PN
 MF-PSML300 = PP
 MF-PSML350 = PS

BIWEEKLY DATE CODE WILL APPEAR ON THE PACKAGING LABEL:
 WEEK 1 AND 2 = A
 WEEK 51 AND 52 = Z



Asia-Pacific:

Tel: +886-2 2562-4117
 Email: asiacus@bourns.com

Europe:

Tel: +36 88 520 390
 Email: eurocus@bourns.com

The Americas:

Tel: +1-951 781-5500
 Email: americus@bourns.com

www.bourns.com

MF-PSML SERIES, REV. A, 05/17

Specifications are subject to change without notice. Users should verify actual device performance in their specific applications.

The device characteristics and parameters in this data sheet can and do vary in different applications and actual device performance may vary over time.

MF-PSML Series Tape and Reel Specifications

BOURNS®

Tape Dimensions	MF-PSML Series per EIA 481-1
W	8.0 ± 0.30 (0.315 ± 0.012)
P ₀	4.0 ± 0.10 (0.157 ± 0.004)
P ₁	4.0 ± 0.10 (0.157 ± 0.004)
P ₂	2.0 ± 0.05 (0.079 ± 0.002)
A ₀	1.70 ± 0.10 (0.067 ± 0.004)
B ₀	2.45 ± 0.10 (0.096 ± 0.004)
B ₁ max.	4.35 (0.171)
D ₀	$1.5 + 0.10/-0.0$ (0.059 + 0.004/-0)
F	3.5 ± 0.05 (0.138 ± 0.002)
E ₁	1.75 ± 0.10 (0.069 ± 0.004)
E ₂ min.	6.25 (0.246)
T max.	0.6 (0.024)
T ₁ max.	0.1 (0.004)
K ₀ (MF-PSML110~MF-PSML200)	0.65 ± 0.10 (0.026 ± 0.004)
K ₀ (MF-PSML260~MF-PSML350)	0.95 ± 0.10 (0.037 ± 0.004)
Leader min.	390 (15.35)
Trailer min.	160 (6.30)
Reel Dimensions	
A max.	185 (7.28)
N min.	50 (1.97)
W ₁	$8.4 + 1.5/-0.0$ (0.331 + 0.059/-0.0)
W ₂ max.	14.4 (0.567)

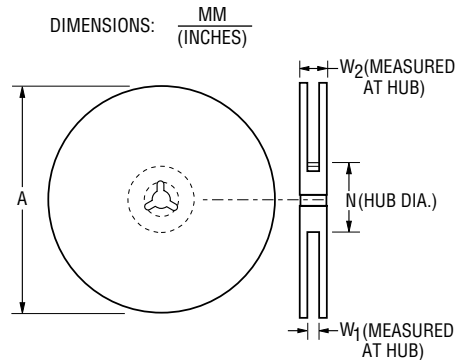
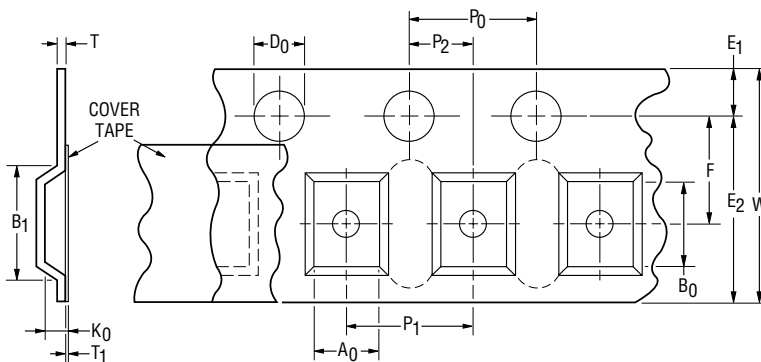

Specifications are subject to change without notice.
 The device characteristics and parameters in this data sheet can and do vary in different applications and actual device performance may vary over time.
 Users should verify actual device performance in their specific applications.



Компания «ЭлектроПласт» предлагает заключение долгосрочных отношений при поставках импортных электронных компонентов на взаимовыгодных условиях!

Наши преимущества:

- Оперативные поставки широкого спектра электронных компонентов отечественного и импортного производства напрямую от производителей и с крупнейших мировых складов;
- Поставка более 17-ти миллионов наименований электронных компонентов;
- Поставка сложных, дефицитных, либо снятых с производства позиций;
- Оперативные сроки поставки под заказ (от 5 рабочих дней);
- Экспресс доставка в любую точку России;
- Техническая поддержка проекта, помощь в подборе аналогов, поставка прототипов;
- Система менеджмента качества сертифицирована по Международному стандарту ISO 9001;
- Лицензия ФСБ на осуществление работ с использованием сведений, составляющих государственную тайну;
- Поставка специализированных компонентов (Xilinx, Altera, Analog Devices, Intersil, Interpoint, Microsemi, Aeroflex, Peregrine, Syfer, Eurofarad, Texas Instrument, Miteq, Cobham, E2V, MA-COM, Hittite, Mini-Circuits, General Dynamics и др.);

Помимо этого, одним из направлений компании «ЭлектроПласт» является направление «Источники питания». Мы предлагаем Вам помощь Конструкторского отдела:

- Подбор оптимального решения, техническое обоснование при выборе компонента;
- Подбор аналогов;
- Консультации по применению компонента;
- Поставка образцов и прототипов;
- Техническая поддержка проекта;
- Защита от снятия компонента с производства.



Как с нами связаться

Телефон: 8 (812) 309 58 32 (многоканальный)

Факс: 8 (812) 320-02-42

Электронная почта: org@eplast1.ru

Адрес: 198099, г. Санкт-Петербург, ул. Калинина, дом 2, корпус 4, литера А.