

EVALUATION KIT
AVAILABLE**MAXIM**

+5V, 18-Bit, Low-Power, Multichannel, Oversampling (Sigma-Delta) ADC

MAX1402

General Description

The MAX1402 low-power, multichannel, serial-output analog-to-digital converter (ADC) features matched 200 μ A current sources for sensor excitation. This ADC uses a sigma-delta modulator with a digital decimation filter to achieve 16-bit accuracy. The digital filter's user-selectable decimation factor allows the conversion resolution to be reduced in exchange for a higher output data rate. True 16-bit performance is achieved at an output data rate of up to 480sps. In addition, the modulator sampling frequency may be optimized for either lowest power dissipation or highest throughput rate. The MAX1402 operates from a +5V supply.

This device offers three fully differential input channels that may be independently programmed with a gain between +1V/V and +128V/V. Furthermore, it can compensate an input-referred DC offset up to 117% of the selected full-scale range. These three differential channels may also be configured to operate as five pseudo-differential input channels. Two additional, fully differential system-calibration channels are provided for gain and offset error correction.

The MAX1402 may be configured to sequentially scan all signal inputs and provide the results via the serial interface with minimum communications overhead. When used with a 2.4576MHz or 1.024MHz master clock, the digital decimation filter can be programmed to produce zeros in its frequency response at the line frequency and associated harmonics, ensuring excellent line rejection without the need for further post-filtering.

The MAX1402 is available in a 28-pin SSOP package.

Applications

Portable Industrial Instruments
Portable Weigh Scales
Loop-Powered Systems
Pressure Transducers

Ordering Information

PART	TEMP RANGE	PIN-PACKAGE	PKG CODE
MAX1402CAI	0°C to +70°C	28 SSOP	A28-2
MAX1402EAI	-40°C to +85°C	28 SSOP	A28-2

SPI and QSPI are trademarks of Motorola, Inc.

Features

- ◆ 18-Bit Resolution, Sigma-Delta ADC
- ◆ 16-Bit Accuracy with No Missing Codes to 480sps
- ◆ Low Quiescent Current
250 μ A (operating mode)
2 μ A (power-down mode)
- ◆ Matched On-Board Current Sources (200 μ A) for Sensor Excitation
- ◆ 3 Fully Differential or 5 Pseudo-Differential Signal Input Channels
- ◆ 2 Additional, Fully Differential Calibration Channels/Auxiliary Input Channels
- ◆ Programmable Gain and Offset
- ◆ Fully Differential Reference Inputs
- ◆ Converts Continuously or On Command
- ◆ Automatic Channel Scanning and Continuous Data Output Mode
- ◆ Operates with +5V Analog Supply and +3V or +5V Digital Supply
- ◆ 3-Wire Serial Interface—SPI™/QSPI™ Compatible
- ◆ 28-Pin SSOP Package

Pin Configuration

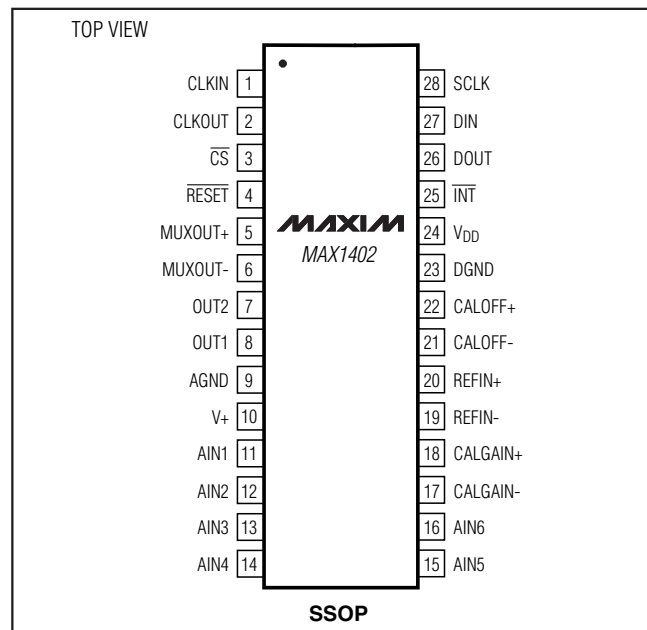
**MAXIM**

Maxim Integrated Products 1

For pricing, delivery, and ordering information, please contact Maxim/Dallas Direct! at 1-888-629-4642, or visit Maxim's website at www.maxim-ic.com.

+5V, 18-Bit, Low-Power, Multichannel, Oversampling (Sigma-Delta) ADC

ABSOLUTE MAXIMUM RATINGS

V₊ to AGND, DGND-0.3V to +6V
 V_{DD} to AGND, DGND-0.3V to +6V
 AGND to DGND.....-0.3V to +0.3V
 Analog Inputs to AGND.....-0.3V to (V₊ + 0.3V)
 Analog Outputs to AGND.....-0.3V to (V₊ + 0.3V)
 Reference Inputs to AGND.....-0.3V to (V₊ + 0.3V)
 CLKIN and CLKOUT to DGND.....-0.3V to (V_{DD} + 0.3V)
 All Other Digital Inputs to DGND.....-0.3V to +6V
 All Digital Outputs to DGND.....-0.3V to (V_{DD} + 0.3V)

Maximum Current Input into Any Pin50mA
 Continuous Power Dissipation (T_A = +70°C)
 28-Pin SSOP (derate 9.52mW/°C above +70°C)524mW
 Operating Temperature Ranges
 MAX1402CAI0°C to +70°C
 MAX1402EAI.....-40°C to +85°C
 Storage Temperature Range-60°C to +150°C
 Lead Temperature (soldering, 10s).....+300°C

Stresses beyond those listed under "Absolute Maximum Ratings" may cause permanent damage to the device. These are stress ratings only, and functional operation of the device at these or any other conditions beyond those indicated in the operational sections of the specifications is not implied. Exposure to absolute maximum rating conditions for extended periods may affect device reliability.

ELECTRICAL CHARACTERISTICS

(V₊ = +5V ±5%, V_{DD} = +2.7V to +5.25V, V_{REFIN+} = +2.50V, REF_{IN-} = AGND, f_{CLKIN} = 2.4576MHz, T_A = T_{MIN} to T_{MAX}, unless otherwise noted. Typical values are at T_A = +25°C.)

PARAMETER	SYMBOL	CONDITIONS	MIN	TYP	MAX	UNITS
STATIC PERFORMANCE						
Noise-Free Resolution		No missing codes guaranteed by design; for filter settings with FS1 = 0	16			Bits
Output Noise		Depends on filter setting and selected gain	Table 16			
Integral Nonlinearity	INL	Bipolar mode, filter settings with FS1 = 0	-0.0015		0.0015	%FSR
Nominal Gain (Note 1)				0.98		
Unipolar Offset Error		Relative to nominal of 1% FSR	-1		2	%FSR
Unipolar Offset Drift		For gains of 1, 2, 4		0.5		μV/°C
		For gains of 8, 16, 32, 64, 128		0.3		
Bipolar Zero Error			-2.0		2.0	%FSR
Bipolar Zero Drift		For gains of 1, 2, 4		0.8		μV/°C
		For gains of 8, 16, 32, 64, 128		0.3		
Positive Full-Scale Error (Note 2)		For gains of 1, 2, 4, 8, 16, 32, 64	-2.5		2.5	%FSR
		For gain of 128	-3.5		3.5	
Full-Scale Drift (Note 3)		For gains of 1, 2, 4		0.8		μV/°C
		For gains of 8, 16, 32, 64, 128		0.3		
Gain Error (Note 4)		For gains of 1, 2, 4, 8, 16, 32, 64	-2		2	%FSR
		For gain of 128	-3		3	
Gain-Error Drift (Note 5)		For gains of 1, 2, 4, 8, 16, 32, 64		1		ppm/°C
		For gain of 128		5		
Bipolar Negative Full-Scale Error		For gains of 1, 2, 4, 8, 16, 32, 64	-2.5		2.5	%FSR
		For gain of 128	-3.5		3.5	
Bipolar Negative Full-Scale Drift		For gains of 1, 2, 4		0.8		μV/°C
		For gains of 8, 16, 32, 64, 128		0.3		

+5V, 18-Bit, Low-Power, Multichannel, Oversampling (Sigma-Delta) ADC

MAX1402

ELECTRICAL CHARACTERISTICS (continued)

(V₊ = +5V ±5%, V_{DD} = +2.7V to +5.25V, V_{REFIN+} = +2.50V, REF_{IN-} = AGND, f_{CLKIN} = 2.4576MHz, T_A = T_{MIN} to T_{MAX}, unless otherwise noted. Typical values are at T_A = +25°C.)

PARAMETER	SYMBOL	CONDITIONS		MIN	TYP	MAX	UNITS
OFFSET DAC							
Offset DAC Range (Note 6)		Unipolar mode		-116.7		116.7	%FSR
		Bipolar mode		-58.35		58.35	
Offset DAC Resolution		Unipolar mode			16.7		%FSR
		Bipolar mode			8.35		
Offset DAC Full-Scale Error		Input referred	Gain = 1, 2, 4, 8, 16, 32, 64	-2.5		2.5	%FSR
			Gain = 128	-3.5		3.5	
Offset DAC Zero-Scale Error					0		%FSR
Additional Noise from Offset DAC (Note 7)		DAC code = 0000			0		μVRMS
ANALOG INPUTS/REFERENCE INPUTS (Specifications for AIN and REF _{IN} , unless otherwise noted.)							
Common-Mode Rejection	CMR	At DC		90			dB
		For filter notch 50Hz, ±0.02 • f _{NOTCH} , MF1 = 0, MF0 = 0, f _{CLKIN} = 2.4576MHz (Note 8)		150			
		For filter notch 60Hz, ±0.02 • f _{NOTCH} , MF1 = 0, MF0 = 0, f _{CLKIN} = 2.4576MHz (Note 8)		150			
Normal-Mode 50Hz Rejection (Note 8)	NMR	For filter notch 50Hz, ±0.02 • f _{NOTCH} , MF1 = 0, MF0 = 0, f _{CLKIN} = 2.4576MHz		100			dB
Normal-Mode 60Hz Rejection (Note 8)	NMR	For filter notch 60Hz, ±0.02 • f _{NOTCH} , MF1 = 0, MF0 = 0, f _{CLKIN} = 2.4576MHz		100			dB
Common-Mode Voltage Range (Note 9)		REF _{IN} and AIN for BUFF = 0		V _{AGND}		V ₊	V
Absolute Input Voltage Range		REF _{IN} and AIN for BUFF = 0		V _{AGND} - 30mV		V ₊ + 30mV	V
Absolute and Common-Mode AIN Voltage Range		BUFF = 1		V _{AGND} + 200mV		V ₊ - 1.5	V
DC Input Leakage Current (Note 10)		REF _{IN} and AIN for BUFF = 0	T _A = +25°C	40			pA
			T _A = T _{MIN} to T _{MAX}			10	nA
AIN Input Current (Note 10)		BUFF = 1				10	nA
AIN Input Capacitance (Note 11)		BUFF = 0	Gain = 1	34			pF
			Gain = 2	38			
			Gain = 4	45			
			Gain = 8, 16, 32, 64, 128	60			
		BUFF = 1, all gains	30				
AIN Differential Voltage Range (Note 12)		Unipolar input range (U/ \bar{B} bit = 1)		0 to V _{REF} / gain			V
		Bipolar input range (U/ \bar{B} bit = 0)		±V _{REF} / gain			

+5V, 18-Bit, Low-Power, Multichannel, Oversampling (Sigma-Delta) ADC

ELECTRICAL CHARACTERISTICS (continued)

(V₊ = +5V ±5%, V_{DD} = +2.7V to +5.25V, V_{REFIN+} = +2.50V, REF_{IN-} = AGND, f_{CLKIN} = 2.4576MHz, T_A = T_{MIN} to T_{MAX}, unless otherwise noted. Typical values are at T_A = +25°C.)

PARAMETER	SYMBOL	CONDITIONS		MIN	TYP	MAX	UNITS
AIN and REF _{IN} Input Sampling Frequency	f _S			(Table 15)			Hz
REF _{IN+} - REF _{IN-} Voltage (Note 13)		±5% for specified performance; functional with lower V _{REF}				2.50	V
LOGIC INPUTS							
Input Current	I _{IN}			-10		+10	μA
Input Low Voltage	V _{IL}	All inputs except CLK _{IN}	V _{DD} = 5V			0.8	V
			V _{DD} = 3.3V			0.4	
		CLK _{IN} only	V _{DD} = 5V			0.8	
			V _{DD} = 3.3V			0.4	
Input High Voltage	V _{IH}	All inputs except CLK _{IN}	V _{DD} = 5V	2			V
			V _{DD} = 3.3V	2			
		CLK _{IN} only	V _{DD} = 5V	3.5			
			V _{DD} = 3.3V	2.4			
Input Hysteresis	V _{HYS}	All inputs except CLK _{IN}	V _{DD} = 5V		200		mV
			V _{DD} = 3.3V		200		
LOGIC OUTPUTS							
Output Low Voltage (Note 14)	V _{OL}	DOUT and $\overline{\text{INT}}$	V _{DD} = 5V, I _{SINK} = 800μA			0.4	V
			V _{DD} = 3.3V, I _{SINK} = 100μA				
		CLK _{OUT}	V _{DD} = 5V, I _{SINK} = 10μA			0.4	
			V _{DD} = 3.3V, I _{SINK} = 10μA				
Output High Voltage (Note 14)	V _{OH}	DOUT and $\overline{\text{INT}}$	V _{DD} = 5V, I _{SOURCE} = 200μA	4			V
			V _{DD} = 3.3V, I _{SOURCE} = 100μA	V _{DD} - 0.3			
		CLK _{OUT}	V _{DD} = 5V, I _{SOURCE} = 10μA	4			
			V _{DD} = 3.3V, I _{SOURCE} = 10μA	V _{DD} - 0.3			
Floating-State Leakage Current	I _L			-10		10	μA
Floating-State Output Capacitance	C _O				9		pF
TRANSDUCER BURN-OUT (Note 15)							
Current	I _{BO}				0.1		μA
Initial Tolerance					±10		%
Drift					±0.05		%/°C
TRANSDUCER EXCITATION CURRENTS							
Current	I _{EXC}				200		μA
Initial Tolerance						15	%
Drift					100		ppm/°C
Match		OUT1 to OUT2				±1	%
Drift Match					5		ppm/°C
Compliance Voltage Range				V _{AGND}		V ₊ - 1.0	V

+5V, 18-Bit, Low-Power, Multichannel, Oversampling (Sigma-Delta) ADC

MAX1402

ELECTRICAL CHARACTERISTICS (continued)

(V+ = +5V ±5%, V_{DD} = +2.7V to +5.25V, V_{REFIN+} = +2.50V, REF_{IN-} = AGND, f_{CLKIN} = 2.4576MHz, T_A = T_{MIN} to T_{MAX}, unless otherwise noted. Typical values are at T_A = +25°C.)

PARAMETER	SYMBOL	CONDITIONS		MIN	TYP	MAX	UNITS
POWER REQUIREMENTS							
V+ Voltage	V+	For specified performance		4.75		5.25	V
V _{DD} Voltage	V _{DD}			2.7		5.25	V
Power-Supply Rejection V+ (Note 16)	PSR			(Note 17)			dB
ANALOG POWER-SUPPLY CURRENT (Measured with digital inputs at either DGND or V _{DD} , external CLKIN, burn-out and auxiliary currents disabled, X2CLK = 0, CLK = 0 for 1.024MHz, CLK = 1 for 2.4576MHz.)							
V+ Standby Current (Note 18)		PD bit = 1, external clock stopped			1	10	μA
V+ Current	I _{V+}	Normal mode, MF1 = 0, MF0 = 0	1.024MHz	Buffers off	175	210	μA
				Buffers on	370	420	
			2.4576MHz	Buffers off	250	300	
				Buffers on	610	700	
		2X mode, MF1 = 0, MF0 = 1	1.024MHz	Buffers off	245		mA
				Buffers on	610		
			2.4576MHz	Buffers off	0.42	0.55	
				Buffers on	1.2	1.5	
		4X mode, MF1 = 1, MF0 = 0	1.024MHz	Buffers off	0.42		mA
				Buffers on	1.2		
			2.4576MHz	Buffers off	1.8	2.2	
				Buffers on	4.8	6	
8X mode, MF1 = 1, MF0 = 1	1.024MHz	Buffers off	1.8		mA		
		Buffers on	4.8				
	2.4576MHz	Buffers off	1.8	2.2			
		Buffers on	4.8	6			
DIGITAL POWER-SUPPLY CURRENT (Measured with digital inputs at either DGND or V _{DD} , external CLKIN, burn-out and auxiliary currents disabled, X2CLK = 0, CLK = 0 for 1.024MHz, CLK = 1 for 2.4576MHz.)							
V _{DD} Standby Current (Note 18)		PD bit = 1, external clock stopped			1	10	μA
3.3V Digital Supply Current	I _{DD}	Normal mode, MF1 = 0, MF0 = 0	1.024MHz		70	200	μA
			2.4576MHz		150	300	
		2X mode, MF1 = 0, MF0 = 1	1.024MHz		0.08		mA
			2.4576MHz		0.17	0.35	
		4X mode, MF1 = 1, MF0 = 0	1.024MHz		0.11		
			2.4576MHz		0.22	0.40	
8X mode, MF1 = 1, MF0 = 1	1.024MHz		0.15				
	2.4576MHz		0.32	0.45			
5V Digital Supply Current	I _{DD}	Normal mode, MF1 = 0, MF0 = 0	1.024MHz		115	300	μA
			2.4576MHz		235	450	
		2X mode, MF1 = 0, MF0 = 1	1.024MHz		0.13		mA
			2.4576MHz		0.28	0.5	

+5V, 18-Bit, Low-Power, Multichannel, Oversampling (Sigma-Delta) ADC

ELECTRICAL CHARACTERISTICS (continued)

(V+ = +5V ±5%, V_{DD} = +2.7V to +5.25V, V_{REFIN+} = +2.50V, REF_{IN-} = AGND, f_{CLKIN} = 2.4576MHz, T_A = T_{MIN} to T_{MAX}, unless otherwise noted. Typical values are at T_A = +25°C.)

PARAMETER	SYMBOL	CONDITIONS		MIN	TYP	MAX	UNITS
5V Digital Supply Current	I _{DD}	4X mode, MF1 = 1, MF0 = 0	1.024MHz		0.17		mA
			2.4576MHz		0.36	0.6	
		8X mode, MF1 = 1, MF0 = 1	1.024MHz		0.24		
			2.4576MHz		0.53	0.8	
5V POWER DISSIPATION (V+ = V _{DD} = +5V, digital inputs = 0 or V _{DD} , external CLK _{IN} , burn-out and auxiliary currents disabled, X2CLK = 0, CLK = 0 for 1.024MHz, CLK = 1 for 2.4576MHz.)							
Power Dissipation	PD	Normal mode, MF1 = 0, MF0 = 0	1.024MHz	Buffers off	1.45	2.55	mW
				Buffers on	2.43	3.6	
			2.4576MHz	Buffers off	2.43	3.75	
				Buffers on	4.23	5.75	
		2X mode, MF1 = 0, MF0 = 1	1.024MHz	Buffers off	1.88		
				Buffers on	3.7		
			2.4576MHz	Buffers off	3.5	5.25	
				Buffers on	7.4	10	
		4X mode, MF1 = 1, MF0 = 0	1.024MHz	Buffers off	2.95		
				Buffers on	6.85		
			2.4576MHz	Buffers off	10.8	14	
				Buffers on	25.8	33	
		8X mode, MF1 = 1, MF0 = 1	1.024MHz	Buffers off	10.2		
				Buffers on	25.2		
			2.4576MHz	Buffers off	11.7	15	
				Buffers on	26.7	34	
Standby Power Dissipation		(Note 18)		10	100	μW	

- Note 1:** Nominal gain is 0.98. This ensures a full-scale input voltage may be applied to the part under all conditions without causing saturation of the digital output data.
- Note 2:** Positive Full-Scale Error includes zero-scale errors (unipolar offset error or bipolar zero error) and applies to both unipolar and bipolar input ranges. This error does not include the nominal gain of 0.98.
- Note 3:** Full-Scale Drift includes zero-scale drift (unipolar offset drift or bipolar zero drift) and applies to both unipolar and bipolar input ranges.
- Note 4:** Gain Error does not include zero-scale errors. It is calculated as (full-scale error - unipolar offset error) for unipolar ranges and as (full-scale error - bipolar zero error) for bipolar ranges. This error does not include the nominal gain of 0.98.
- Note 5:** Gain-Error Drift does not include unipolar offset drift or bipolar zero drift. It is effectively the drift of the part if zero-scale error is removed.
- Note 6:** Use of the offset DAC does not imply that any input may be taken below AGND.
- Note 7:** Additional noise added by the offset DAC is dependent on the filter cutoff, gain, and DAC setting. No noise is added for a DAC code of 0000.
- Note 8:** Guaranteed by design or characterization; not production tested.
- Note 9:** The absolute input voltage must be within the input-voltage range specification.
- Note 10:** All AIN and REF_{IN} pins have identical input structures. Leakage is production tested only for the AIN3, AIN4, AIN5, CALGAIN and CALOFF inputs.
- Note 11:** The dynamic load presented by the MAX1402 analog inputs for each gain setting is discussed in detail in the *Switching Network* Section. Values are provided for the maximum allowable external series resistance.

+5V, 18-Bit, Low-Power, Multichannel, Oversampling (Sigma-Delta) ADC

MAX1402

- Note 12:** The input voltage range for the analog inputs is with respect to the voltage on the negative input of its respective differential or pseudo-differential pair. Table 5 shows which inputs form differential pairs.
- Note 13:** $V_{REF} = V_{REFIN+} - V_{REFIN-}$.
- Note 14:** These specifications apply to CLKOUT only when driving a single CMOS load.
- Note 15:** The burn-out currents require a 500mV overhead between the analog input voltage and both V+ and AGND to operate correctly.
- Note 16:** Measured at DC in the selected passband. PSR at 50Hz will exceed 120dB with filter notches of 25Hz or 50Hz and FAST bit = 0. PSR at 60Hz will exceed 120dB with filter notches of 20Hz or 60Hz and FAST bit = 0.
- Note 17:** PSR depends on gain. For a gain of +1V/V, PSR is 70dB typical. For a gain of +2V/V, PSR is 75dB typical. For a gain of +4V/V, PSR is 80dB typical. For gains of +8V/V to +128V/V, PSR is 85dB typical.
- Note 18:** Standby power-dissipation and current specifications are valid only with CLKIN driven by an external clock and with the external clock stopped. If the clock continues to run in standby mode, the power dissipation will be considerably higher.

TIMING CHARACTERISTICS

(V+ = +5V ±5%, V_{DD} = +2.7V to +5.25V, AGND = DGND, f_{CLKIN} = 2.4576MHz; input logic 0 = 0V; logic 1 = V_{DD}, T_A = T_{MIN} to T_{MAX}, unless otherwise noted.) (Notes 19, 20, 21)

PARAMETER	SYMBOL	CONDITIONS	MIN	TYP	MAX	UNITS
Master Clock Frequency	f _{CLKIN}	Crystal oscillator or clock externally supplied for specified performance (Notes 22, 23)	X2CLK = 0	0.4	2.5	MHz
			X2CLK = 1	0.8	5.0	
Master Clock Input Low Time	f _{CLKIN LO}	t _{CLKIN} = 1 / f _{CLKIN} , X2CLK = 0	0.4 • t _{CLKIN}			ns
Master Clock Input High Time	f _{CLKIN HI}	t _{CLKIN} = 1 / f _{CLKIN} , X2CLK = 0	0.4 • t _{CLKIN}			ns
$\overline{\text{INT}}$ High Time	t _{INT}	X2CLK = 0, N = 2 ^(2 • MF1 + MF0)	280 / N • t _{CLKIN}			ns
		X2CLK = 1, N = 2 ^(2 • MF1 + MF0)	560 / N • t _{CLKIN}			
$\overline{\text{RESET}}$ Pulse Width Low	t ₂		100			ns
SERIAL-INTERFACE READ OPERATION						
$\overline{\text{INT}}$ to $\overline{\text{CS}}$ Setup Time (Note 8)	t ₃		0			ns
SCLK Setup to Falling Edge $\overline{\text{CS}}$	t ₄		30			ns
$\overline{\text{CS}}$ Falling Edge to SCLK Falling Edge Setup Time	t ₅		30			ns
SCLK Falling Edge to Data Valid Delay (Notes 24, 25)	t ₆	V _{DD} = 5V	0			ns
		V _{DD} = 3.3V	80			
SCLK High Pulse Width	t ₇		100			ns
SCLK Low Pulse Width	t ₈		100			ns
$\overline{\text{CS}}$ Rising Edge to SCLK Rising Edge Hold Time (Note 21)	t ₉		0			ns
Bus Relinquish Time After SCLK Rising Edge (Note 26)	t ₁₀	V _{DD} = 5V	10			ns
		V _{DD} = 3.3V	70			
SCLK Rising Edge to $\overline{\text{INT}}$ High (Note 27)	t ₁₁	V _{DD} = 5V	100			ns
		V _{DD} = 3.3V	200			
SERIAL-INTERFACE WRITE OPERATION						
SCLK Setup to Falling Edge $\overline{\text{CS}}$	t ₁₂		30			ns

+5V, 18-Bit, Low-Power, Multichannel, Oversampling (Sigma-Delta) ADC

TIMING CHARACTERISTICS (continued)

($V_+ = +5V \pm 5\%$, $V_{DD} = +2.7V$ to $+5.25V$, $AGND = DGND$, $f_{CLKIN} = 2.4576MHz$; input logic 0 = 0V; logic 1 = V_{DD} , $T_A = T_{MIN}$ to T_{MAX} , unless otherwise noted.) (Notes 19, 20, 21)

PARAMETER	SYMBOL	CONDITIONS	MIN	TYP	MAX	UNITS
\overline{CS} Falling Edge to SCLK Falling Edge Setup Time	t_{13}		30			ns
Data Valid to SCLK Rising Edge Setup Time	t_{14}		30			ns
Data Valid to SCLK Rising Edge Hold Time	t_{15}		0			ns
SCLK High Pulse Width	t_{16}		100			ns
SCLK Low Pulse Width	t_{17}		100			ns
\overline{CS} Rising Edge to SCLK Rising Edge Hold Time	t_{18}		0			ns
AUXILIARY DIGITAL INPUTS (DS0 and DS1)						
DS0/DS1 to SCLK Falling Edge Setup Time (Notes 21 & 28)	t_{19}		40			ns
DS0/DS1 to SCLK Falling Edge Hold Time (Notes 21 & 28)	t_{20}		0			ns

Note 19: All input signals are specified with $t_r = t_f = 5ns$ (10% to 90% of V_{DD}) and timed from a voltage level of 1.6V.

Note 20: See Figure 4.

Note 21: Timings shown in tables are for the case where SCLK idles high between accesses. The part may also be used with the SCLK idling low between accesses, provided \overline{CS} is toggled. In this case SCLK in the timing diagrams should be inverted and the terms "SCLK Falling Edge" and "SCLK Rising Edge" exchanged in the specification tables. If \overline{CS} is permanently tied low, the part should only be operated with SCLK idling high between accesses.

Note 22: CLKIN duty cycle range is 45% to 55%. CLKIN must be supplied whenever the MAX1402 is not in standby mode. If no clock is present, the device can draw higher current than specified.

Note 23: The MAX1402 is production tested with f_{CLKIN} at 2.5MHz (1MHz for some I_{DD} tests).

Note 24: Measured with the load circuit of Figure 1 and defined as the time required for the output to cross the V_{OL} or V_{OH} limits.

Note 25: For read operations, SCLK active edge is falling edge of SCLK.

Note 26: Derived from the time taken by the data output to change 0.5V when loaded with the circuit of Figure 1. The number is then extrapolated back to remove effects of charging or discharging the 50pF capacitor. This ensures that the times quoted in the timing characteristics are true bus-relinquish times and are independent of external bus loading capacitances.

Note 27: \overline{INT} returns high after the first read after an output update. The same data can be read again while \overline{INT} is high, but be careful not to allow subsequent reads to occur close to the next output update.

Note 28: Auxiliary inputs DS0 and DS1 are latched on the first falling edge of SCLK during a data-read cycle.

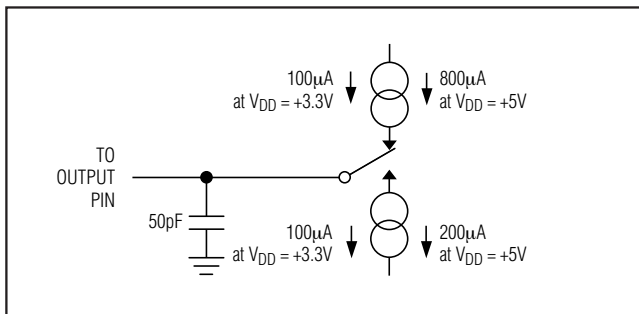

Figure 1. Load Circuit for Bus-Relinquish Time and V_{OL} and V_{OH} Levels

+5V, 18-Bit, Low-Power, Multichannel, Oversampling (Sigma-Delta) ADC

MAX1402

Typical Operating Characteristics

($V_+ = +5V$, $V_{DD} = +5V$, $V_{REFIN+} = +2.50V$, $REFIN- = AGND$, $f_{CLKIN} = 2.4576MHz$, $T_A = +25^\circ C$, unless otherwise noted.)

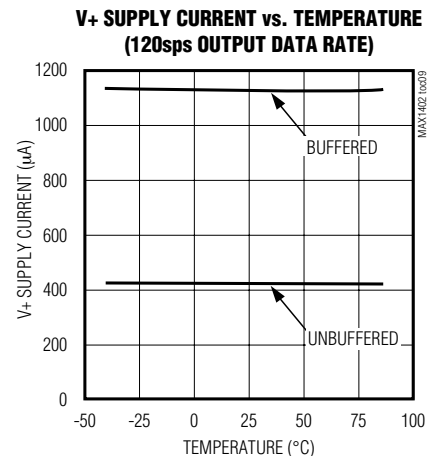
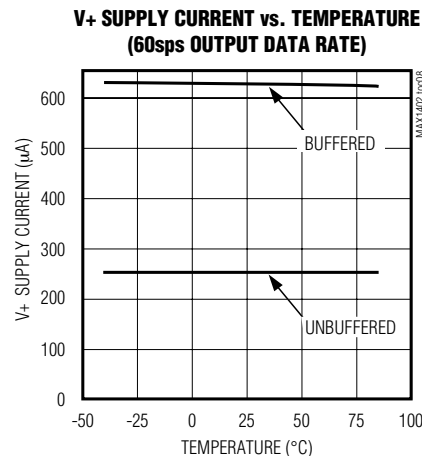
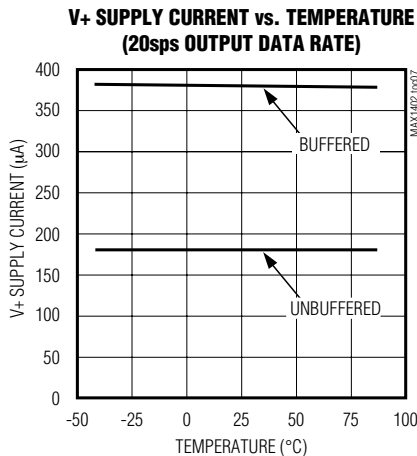
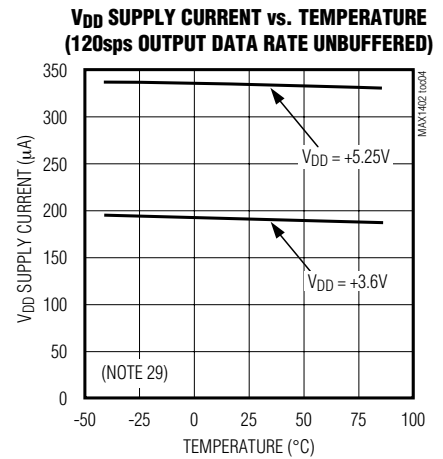
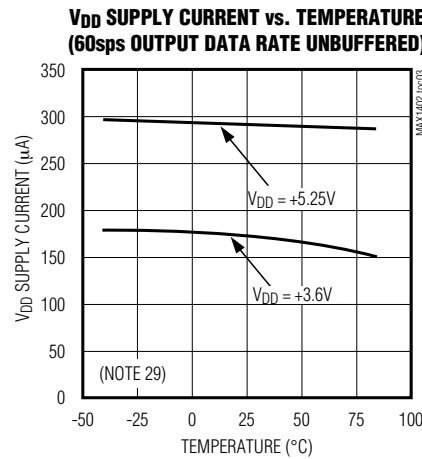
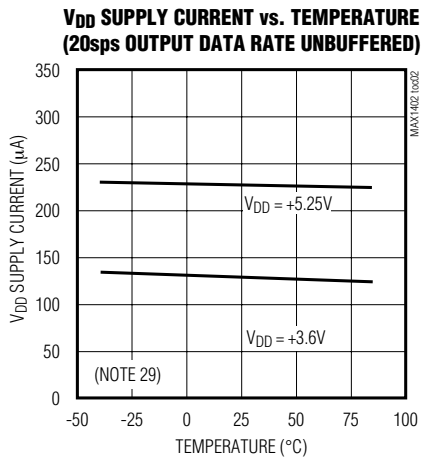
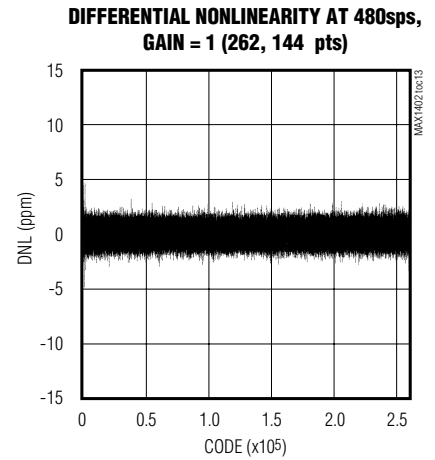
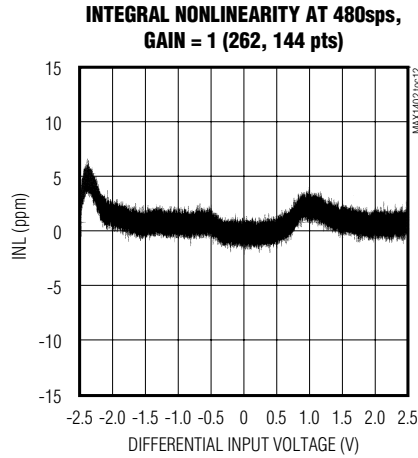
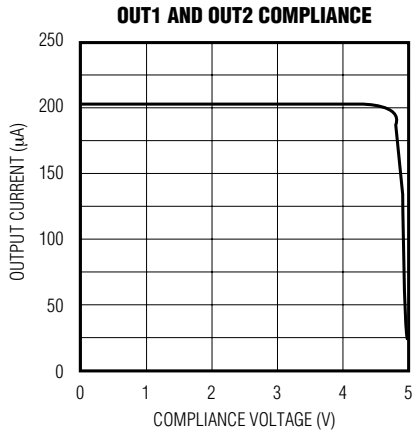

+5V, 18-Bit, Low-Power, Multichannel, Oversampling (Sigma-Delta) ADC

Typical Operating Characteristics (continued)

(V+ = +5V, V_{DD} = +5V, V_{REFIN+} = +2.50V, REF_{IN-} = AGND, f_{CLKIN} = 2.4576MHz, T_A = +25°C, unless otherwise noted.)

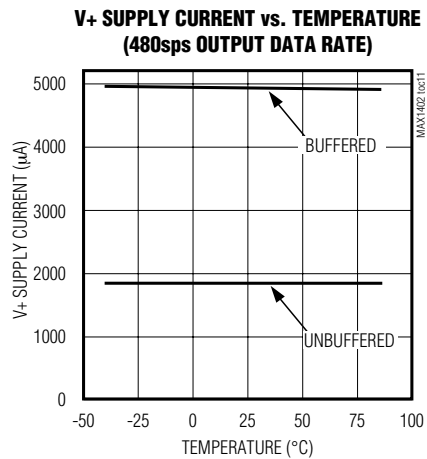
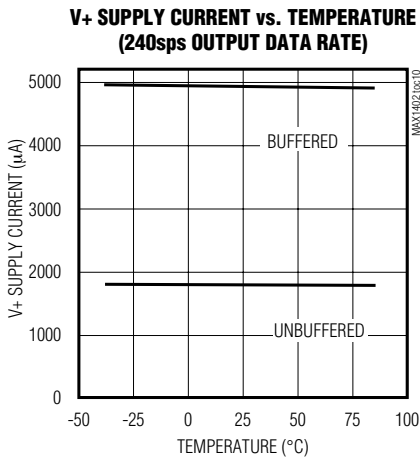
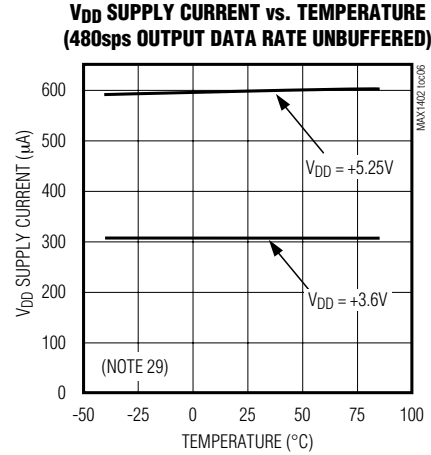
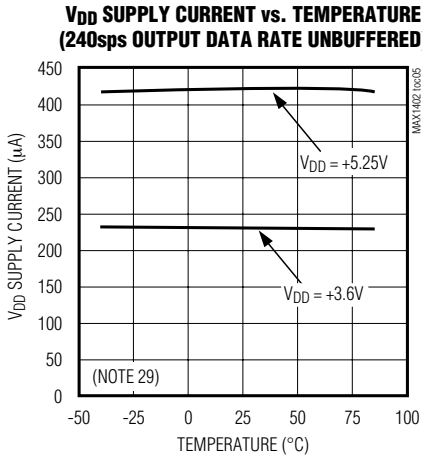

Note 29: Minimize capacitive loading at CLKOUT for lowest V_{DD} supply current. *Typical Operating Characteristics* show V_{DD} supply current with CLKOUT loaded by 120pF.

+5V, 18-Bit, Low-Power, Multichannel, Oversampling (Sigma-Delta) ADC

Pin Description

MAX1402

PIN	NAME	FUNCTION
1	CLKIN	Clock Input. A crystal can be connected across CLKIN and CLKOUT. Alternatively, drive CLKIN with a CMOS-compatible clock at a nominal frequency of 2.4576MHz or 1.024MHz, and leave CLKOUT unconnected. Frequencies of 4.9152MHz and 2.048MHz may be used if the X2CLK control bit is set to 1.
2	CLKOUT	Clock Output. When deriving the master clock from a crystal, connect the crystal between CLKIN and CLKOUT. In this mode, the on-chip clock signal is not available at CLKOUT. Leave CLKOUT unconnected when CLKIN is driven with an external clock.
3	\overline{CS}	Chip-Select Input. Active-low logic input used to enable the digital interface. With \overline{CS} hard-wired low, the MAX1402 operates in its 3-wire interface mode with SCLK, DIN and DOUT used to interface to the device. \overline{CS} is used either to select the device in systems with more than one device on the serial bus, or as a frame-synchronization signal for the MAX1402 when a continuous SCLK is used.
4	\overline{RESET}	Active-Low Reset Input. Drive low to reset the control logic, interface logic, digital filter and analog modulator to power-on status. \overline{RESET} must be high and CLKIN must be toggling in order to exit reset.
5	DS1	Digital Input for Auxiliary Data Input Bit 1. The status of this bit is reflected in the output data by bit D4. Used to communicate the status of DS1 via the serial interface.
6	DS0	Digital Input for Auxiliary Data Input Bit 0. The status of this bit is reflected in the output data by bit D3. Used to communicate the status of DS0 via the serial interface.
7	OUT2	Transducer Excitation Current Source 2
8	OUT1	Transducer Excitation Current Source 1
9	AGND	Analog Ground. Reference point for the analog circuitry. AGND connects to the IC substrate.
10	V+	Analog Positive Supply Voltage (+4.75V to +5.25V).
11	AIN1	Analog Input Channel 1. May be used as a pseudo-differential input with AIN6 as common, or as the positive input of the AIN1/AIN2 differential analog input pair (see <i>Communications Register</i> section).
12	AIN2	Analog Input Channel 2. May be used as a pseudo-differential input with AIN6 as common, or as the negative input of the AIN1/AIN2 differential analog input pair (see <i>Communications Register</i> section).
13	AIN3	Analog Input Channel 3. May be used as a pseudo-differential input with AIN6 as common, or as the positive input of the AIN3/AIN4 differential analog input pair (see <i>Communications Register</i> section).
14	AIN4	Analog Input Channel 4. May be used as a pseudo-differential input with AIN6 as common, or as the negative input of the AIN3/AIN4 differential analog input pair (see <i>Communications Register</i> section).
15	AIN5	Analog Input Channel 5. Used as a differential or pseudo-differential input with AIN6 (see <i>Communications Register</i> section).
16	AIN6	Analog Input 6. May be used as a common point for AIN1 through AIN5 in pseudo-differential mode, or as the negative input of the AIN5/AIN6 differential analog input pair (see <i>Communications Register</i> section).

+5V, 18-Bit, Low-Power, Multichannel, Oversampling (Sigma-Delta) ADC

Pin Description (continued)

PIN	NAME	FUNCTION
17	CALGAIN-	Negative Gain Calibration Input. Used for system-gain calibration. It forms the negative input of a fully differential input pair with CALGAIN+. Normally these inputs are connected to reference voltages in the system. When system gain calibration is not required and the auto-sequence mode is used, the CALGAIN+/CALGAIN- input pair provides an additional fully differential input channel.
18	CALGAIN+	Positive Gain Calibration Input. Used for system gain calibration. It forms the positive input of a fully differential input pair with CALGAIN-. Normally these inputs are connected to reference voltages in the system. When system gain calibration is not required and the auto-sequence mode is used, the CALGAIN+/CALGAIN- input pair provides an additional fully differential input channel.
19	REFIN-	Negative Differential Reference Input. Bias REFIN- between V+ and AGND, provided that REFIN+ is more positive than REFIN-.
20	REFIN+	Positive Differential Reference Input. Bias REFIN+ between V+ and AGND, provided that REFIN+ is more positive than REFIN-.
21	CALOFF-	Negative Offset Calibration Input. Used for system offset calibration. It forms the negative input of a fully differential input pair with CALOFF+. Normally these inputs are connected to zero-reference voltages in the system. When system offset calibration is not required and the auto-sequence mode is used, the CALOFF+/CALOFF- input pair provides an additional fully differential input channel.
22	CALOFF+	Positive Offset Calibration Input. Used for system offset calibration. It forms the positive input of a fully differential input pair with CALOFF-. Normally these inputs are connected to zero-reference voltages in the system. When system offset calibration is not required and the auto-sequence mode is used, the CALOFF+/CALOFF- input pair provides an additional fully differential input channel.
23	DGND	Digital Ground. Reference point for digital circuitry.
24	V _{DD}	Digital Supply Voltage (+2.7V to +5.25V)
25	$\overline{\text{INT}}$	Interrupt Output. A logic low indicates that a new output word is available from the data register. $\overline{\text{INT}}$ returns high upon completion of a full output word read operation. $\overline{\text{INT}}$ also returns high for short periods (determined by the filter and clock control bits) if no data read has taken place. A logic high indicates internal activity, and a read operation should not be attempted under this condition. $\overline{\text{INT}}$ can also provide a strobe to indicate valid data at DOUT (MDOUT = 1).
26	DOUT	Serial Data Output. DOUT outputs data from the internal shift register containing information from the Communications Register, Global Setup Registers, Transfer Function Registers, or Data Register. DOUT can also provide the digital bit stream directly from the Σ - Δ modulator (MDOUT = 1).
27	DIN	Serial Data Input. Data on DIN is written to the input shift register and later transferred to the Communications Register, Global Setup Registers, Special Function Register, or Transfer Function Registers, depending on the register selection bits in the Communications Register.
28	SCLK	Serial Clock Input. Apply an external serial clock to transfer data to and from the MAX1402. This serial clock can be continuous, with data transmitted in a train of pulses, or intermittent. If $\overline{\text{CS}}$ is used to frame the data transfer, then SCLK may idle high or low between conversions and $\overline{\text{CS}}$ determines the desired active clock edge (see <i>Selecting Clock Polarity</i>). If $\overline{\text{CS}}$ is tied permanently low, SCLK must idle high between data transfers.

+5V, 18-Bit, Low-Power, Multichannel, Oversampling (Sigma-Delta) ADC

MAX1402

Detailed Description

Circuit Description

The MAX1402 is a low-power, multichannel, serial-output, sigma-delta ADC designed for applications with a wide dynamic range, such as weigh scales and pressure transducers. The functional block diagram in Figure 2 contains a switching network, a modulator, a PGA, two buffers, an oscillator, an on-chip digital filter, and a bidirectional serial communications port.

Three fully-differential input channels feed into the switching network. Each channel may be independently programmed with a gain between +1V/V and +128V/V. These three differential channels may also be configured to operate as five pseudo-differential input channels. Two additional, fully differential system-calibration channels allow system gain and offset error to be measured. These system-calibration channels can be used as additional differential signal channels when dedicated gain and offset error correction channels are not required.

Two chopper-stabilized buffers are available to isolate the selected inputs from the capacitive loading of the PGA and modulator. Three independent DACs provide compensation for the DC component of the input signal on each of the differential input channels.

The sigma-delta modulator converts the input signal into a digital pulse train whose average duty cycle represents the digitized signal information. The pulse train is then processed by a digital decimation filter, resulting in a conversion accuracy exceeding 16 bits. The digital filter's decimation factor is user-selectable, which allows the conversion result's resolution to be reduced to achieve a higher output data rate. When used with 2.4576MHz or 1.024MHz master clocks, the decimation filter can be programmed to produce zeros in its frequency response at the line frequency and associated harmonics. This ensures excellent line rejection without the need for further post-filtering. In addition, the modulator sampling frequency can be optimized for either lowest power dissipation or highest output data rate.

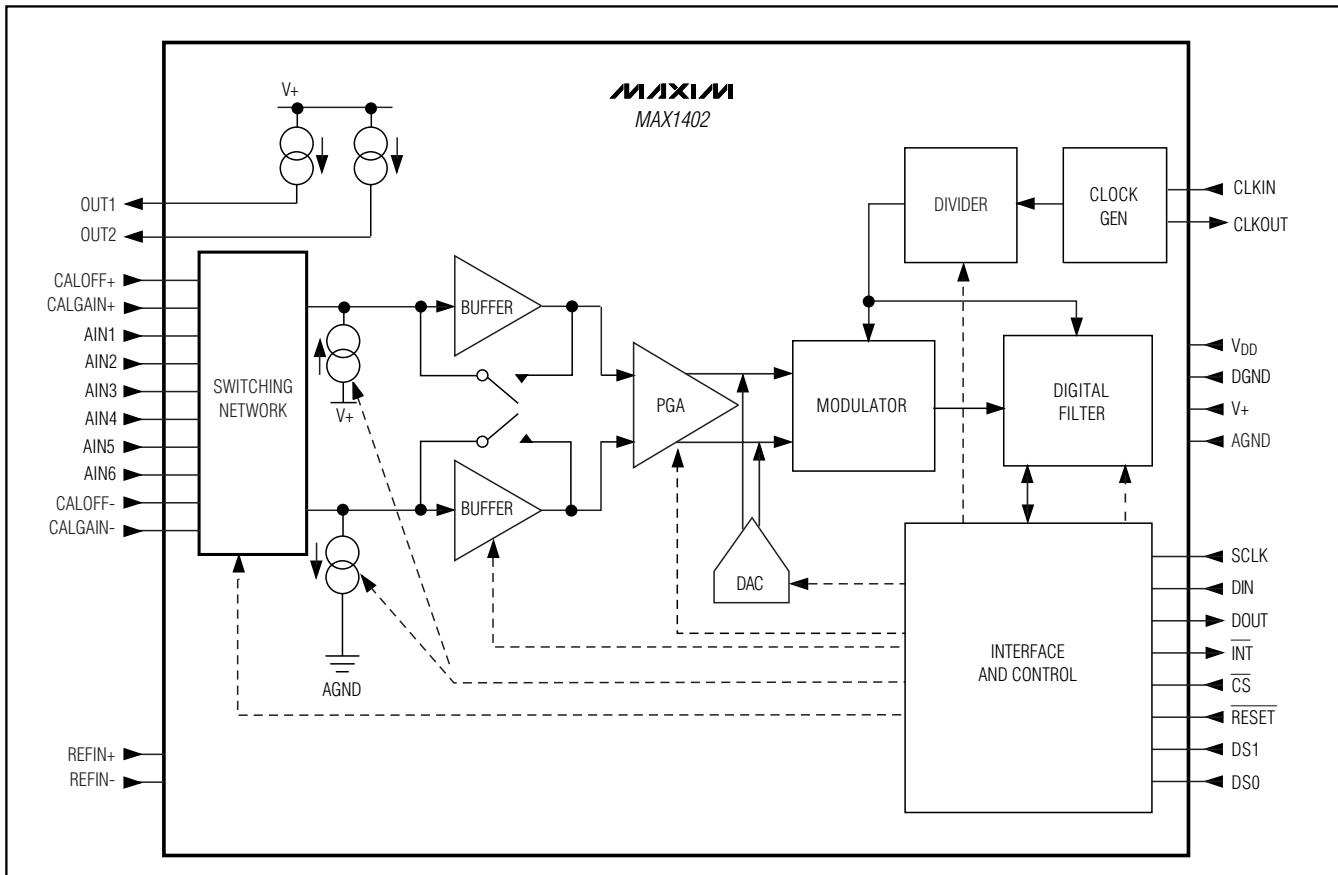

Figure 2. Functional Diagram

+5V, 18-Bit, Low-Power, Multichannel, Oversampling (Sigma-Delta) ADC

The MAX1402 can be configured to sequentially scan all signal inputs and to transmit the results through the serial interface with minimum communications overhead. The output word contains a result identification tag to indicate the source of each conversion result.

Serial Digital Interface

The serial digital interface provides access to eight on-chip registers (Figure 3). All serial-interface commands begin with a write to the communications register (COMM). On power-up, system reset, or interface reset, the part expects a write to its communications register. The COMM register access begins with a 0 start bit. The COMM register R/W bit selects a read or write operation, and the register select bits (RS2, RS1, RS0) select the register to be addressed. Hold DIN high when not writing to COMM or another register (Table 1).

The serial interface consists of five signals: \overline{CS} , SCLK, DIN, DOUT, and \overline{INT} . Clock pulses on SCLK shift bits into DIN and out of DOUT. \overline{INT} provides an indication that data is available. \overline{CS} is a device chip-select input as well as a clock polarity select input (Figure 4). Using \overline{CS} allows the SCLK, DIN, and DOUT signals to be shared among several SPI-compatible devices. When short on I/O pins, connect \overline{CS} low and operate the serial digital interface in CPOL = 1, CPHA = 1 mode using SCLK, DIN, and DOUT. This 3-wire interface mode is ideal for opto-isolated applications. Furthermore, a microcontroller (such as a PIC16C54 or 80C51) can use a single bidirectional I/O pin for both sending to DIN and receiving from DOUT (see *Applications Information*), because the MAX1402 drives DOUT only during a read cycle.

Additionally, connecting the \overline{INT} signal to a hardware interrupt allows faster throughput and reliable, collision-free data flow.

Table 1. Control Register Addressing

RS2	RS1	RS0	TARGET REGISTER
0	0	0	Communications Register
0	0	1	Global Setup Register 1
0	1	0	Global Setup Register 2
0	1	1	Special Function Register
1	0	0	Transfer Function Register 1
1	0	1	Transfer Function Register 2
1	1	0	Transfer Function Register 3
1	1	1	Data Register

The MAX1402 features a mode where the raw modulator data output is accessible. In this mode the DOUT and \overline{INT} functions are reassigned (see the *Modulator Data Output* section).

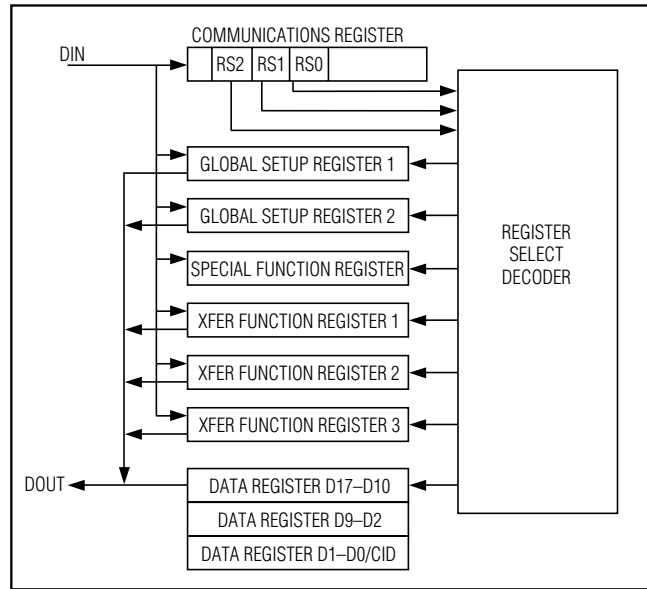

Figure 3. Register Summary

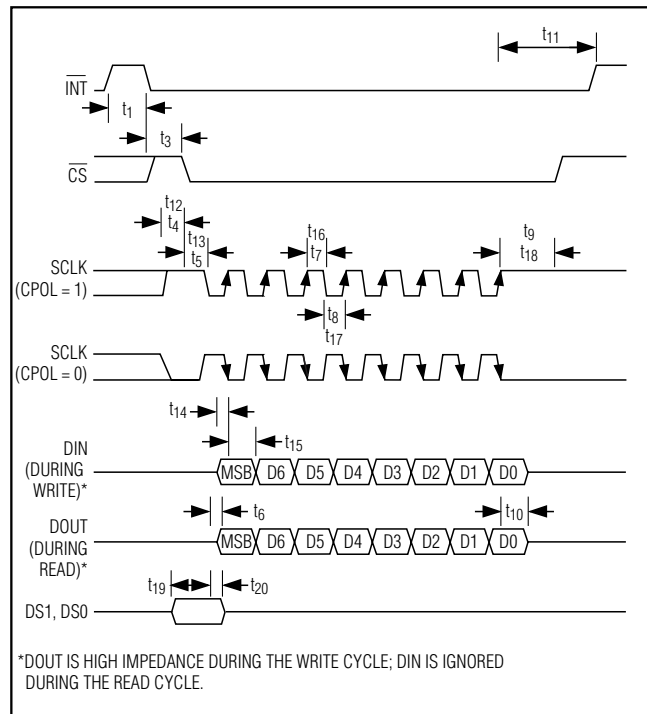

Figure 4. Serial-Interface Timing

+5V, 18-Bit, Low-Power, Multichannel, Oversampling (Sigma-Delta) ADC

Selecting Clock Polarity

The serial interface can be operated with the clock idling either high or low. This is compatible with Motorola's SPI interface operated in CPOL = 1, CPHA = 1 or CPOL = 0, CPHA = 1 mode. Select the clock polarity by sampling the state of SCLK at the falling edge of \overline{CS} . Ensure that the setup times t_4/t_{12} and t_5/t_{13} are not violated. If \overline{CS} is connected to ground, resulting in no falling edge on \overline{CS} , SCLK must idle high (CPOL = 1, CPHA = 1).

Data-Ready Signal (DRDY bit true or \overline{INT} = low)

The data-ready signal indicates that new data may be read from the 24-bit data register. After the end of a successful data register read, the data-ready signal becomes false. If a new measurement completes before the data is read, the data-ready signal becomes false. The data-ready signal becomes true again when new data is available in the data register.

The MAX1402 provides two methods of monitoring the data-ready signal. \overline{INT} provides a hardware solution (active low when data is ready to be accessed), while the DRDY bit in the COMM register provides a software solution (active high).

Read data as soon as possible once data-ready becomes true. This becomes increasingly important for faster measurement rates. If the data-read is delayed significantly, a collision may result. A collision occurs when a new measurement completes during a data-register read operation. After a collision, information in the data register is invalid. The failed read operation must be completed even though the data is invalid.

Resetting the Interface

Reset the serial interface by clocking in 32 1s. Resetting the interface does not affect the internal registers.

If continuous data output mode is in use, clock in eight 0s followed by 32 1s. More than 32 1s may be clocked in, since a leading 0 is used as the start bit for all operations.

Continuous Data Output Mode

When scanning the input channels (SCAN = 1), the serial interface allows the data register to be read repeatedly without requiring a write to the COMM register.

Communications Register

First Bit (MSB)

(LSB)

FUNCTION	DATA RDY	REGISTER SELECT BITS						
Name	0/DRDY	RS2	RS1	RS0	R/ \overline{W}	RESET	STDBY	FSYNC
Defaults	0	0	0	0	0	0	0	0

The initial COMM write (01111000) is followed by 24 clocks (DIN = high) to read the 24-bit data register. Once the data register has been read, it can be read again after the next conversion by writing another 24 clocks (DIN = high). Terminate the continuous data output mode by writing to the COMM register with any valid access.

Modulator Data Output (MDOUT = 1)

Single-bit, raw modulator data is available at DOUT for custom filtering when MDOUT = 1. \overline{INT} provides a modulator clock for data synchronization. Data is valid on the falling edge of \overline{INT} . Write operations can still be performed, however, read operations are disabled. After MDOUT is returned to 0, valid data is accessed by the normal serial-interface read operation.

On-Chip Registers

Communications Register

0/DRDY: (Default = 0) Data Ready Bit. On a write, this bit must be reset to 0 to signal the start of the Communications Register data word. On a read, a 1 in this location (0/DRDY) signifies that valid data is available in the data register. This bit is reset after the data register is read or, if data is not read, 0/DRDY will go low at the end of the next measurement.

RS2, RS1, RS0: (Default = 0, 0, 0) Register Select Bits. These bits select the register to be accessed (Table 1).

R/ \overline{W} : (Default = 0) Read/Write Bit. When set high, the selected register is read; when R/ \overline{W} = 0, the selected register is written.

RESET: (Default = 0) Software Reset Bit. Setting this bit high causes the part to be reset to its default power-up condition (RESET = 0).

STDBY: (Default = 0) Standby Power-Down Bit. Setting the STDBY bit places the part in "standby" condition, shutting down everything except the serial interface and the CLK oscillator.

FSYNC: (Default = 0) Filter Sync Bit. When FSYNC = 0, conversions are automatically performed at a data rate determined by CLK, FS1, FS0, MF1, and MF0 bits. When FSYNC = 1, the digital filter and analog modulator

+5V, 18-Bit, Low-Power, Multichannel, Oversampling (Sigma-Delta) ADC

are held in reset, inhibiting normal self-timed operation. This bit may be used to convert on command to minimize the settling time to valid output data, or to synchronize operation of a number of MAX1402s. FSYNC does not reset the serial interface or the 0/DRDY flag. To clear the 0/DRDY flag while FSYNC is active, simply read the data register.

Global Setup Register 1

A1, A0: (Default = 0, 0) Channel-Selection Control Bits. These bits (combined with the state of the DIFF, M1, and M0 bits) determine the channel selected for conversion according to Tables 8, 9, and 10. These bits are ignored if the SCAN bit is set.

MF1, MF0: (Default = 0, 0) Modulator Frequency Bits. MF1 and MF0 determine the ratio of CLKIN oscillator frequency to modulator operating frequency. They affect the output data rate, the position of the digital filter notch frequencies, and the power dissipation of the device. Achieve lowest power dissipation with MF1 = 0 and MF0 = 0. Highest power dissipation and fastest output data rate occur with these bits set to 1, 1 (Table 2).

CLK: (Default = 1) CLK Bit. The CLK bit is used in conjunction with X2CLK to tell the MAX1402 the frequency of the CLKIN input signal. If CLK = 0, a CLKIN input frequency of 1.024MHz (2.048MHz for X2CLK = 1) is expected. If CLK = 1, a CLKIN input frequency of 2.4576MHz (4.9152MHz for X2CLK = 1) is expected. This bit affects the decimation factor in the digital filter and thus the output data rate (Table 2).

FS1, FS0: (Default = 0, 1) Filter Selection Bits. These bits (in conjunction with the CLK bit) control the decimation ratio of the digital filter. They determine the output data rate, the position of the digital filter-frequency response notches, and the noise present in the output result. (Table 2).

FAST: (Default 0) FAST Bit. FAST = 0 causes the digital filter to perform a SINC³ filter function on the modulator data stream. The output data rate will be determined by the values in the CLK, FS1, FS0, MF1, and MF0 bits (Table 2). The settling time for SINC³ function is $3 \cdot [1 / (\text{output data rate})]$. In SINC³ mode, the MAX1402 automatically holds the DRDY signal false (after any significant configuration change) until settled data is available. FAST = 1 causes the digital filter to perform a SINC¹ filter function on the modulator data stream. The signal-to-noise ratio achieved with this filter function is less than that of the SINC³ filter; however SINC¹ settles in a single output sample period, rather than a minimum of three output sample periods for SINC³. When switching from SINC¹ to SINC³ mode, the DRDY flag will be deasserted and reasserted after the filter has fully settled. This mode change requires a minimum of three samples.

Global Setup Register 2

SCAN: (Default = 0) Scan Bit. Setting this bit to a 1 causes sequential scanning of the input channels as determined by DIFF, M1, and M0 (see *Scanning (Scan-Mode)*). When SCAN = 0, the MAX1402 repeatedly measures the unique channel selected by A1, A0, DIFF, M1, and M0 (Table 4).

M1, M0: (Default 0, 0) Mode Control Bits. These bits control access to the calibration channels CALOFF and CALGAIN. When SCAN = 0, setting M1 = 0 and M0 = 1 selects the CALOFF input, and M1 = 1 and M0 = 0 selects the CALGAIN input (Table 3). When SCAN = 1 and M1 \neq M0, the scanning sequence includes both CALOFF and CALGAIN inputs (Table 4). When SCAN is set to 1 and the device is scanning the available input channels, selection of either calibration mode (01 or 10) will cause the scanning sequence to be extended to include a conversion on both the CALGAIN+/CALGAIN- input pair and the CALOFF+/CALOFF- input

Global Setup Register 1

First Bit (MSB)

(LSB)

FUNCTION	CHANNEL SELECTION		MODULATOR FREQUENCY		CLK	FILTER SELECTION		FAST
	A1	A0	MF1	MF0		FS1	FS0	
Name	A1	A0	MF1	MF0	CLK	FS1	FS0	FAST
Defaults	0	0	0	0	1	0	1	0

Global Setup Register 2

First Bit (MSB)

(LSB)

FUNCTION	SCAN	MODE CONTROL		BUFF	DIFF	BOUT	IOUT	X2CLK
		M1	M0					
Name	SCAN	M1	M0	BUFF	DIFF	BOUT	IOUT	X2CLK
Defaults	0	0	0	0	0	0	0	0

+5V, 18-Bit, Low-Power, Multichannel, Oversampling (Sigma-Delta) ADC

MAX1402

pair. The exact sequence depends on the state of the DIFF bit (Table 4). When scanning, the calibration channels use the PGA gain, format, and DAC settings defined by the contents of Transfer Function Register 3.

BUFF: (Default = 0) The BUFF bit controls operation of the input buffer amplifiers. When this bit is 0, the internal buffers are bypassed and powered down. When this bit is set high, the buffers drive the input sampling capacitors and minimize the dynamic input load.

DIFF: (Default = 0) Differential/Pseudo-Differential Bit. When DIFF = 0, the part is in pseudo-differential mode, and AIN1–AIN5 are measured respective to AIN6, the analog common. When DIFF = 1, the part is in differential mode with the analog inputs defined as AIN1/AIN2, AIN3/AIN4, and AIN5/AIN6. The available input channels for each mode are tabulated in Table 5. Note that DIFF also affects the scanning sequence when the part is placed in SCAN mode (Table 4).

BOUT: (Default = 0) Burn-out Current Bit. Setting BOUT = 1 connects 100nA current sources to the selected analog input channel. This mode is used to check that a transducer has not burned out or opened circuit. The burn-out current source must be turned off (BOUT = 0) before measurement to ensure best linearity.

IOUT: (Default = 0) The IOUT bit controls the Transducer Excitation Currents. A '0' in this bit disables OUT1 and OUT2 effectively making these pins high-impedance. A '1' in this location activates both IOUT1 and IOUT2 causing each pin to source 200µA.

X2CLK: (Default = 0) Times-Two Clock Bit. Setting this bit to 1 selects a divide-by-2 prescaler in the clock signal path. This allows use of a higher frequency crystal or clock source and improves immunity to asymmetric clock sources.

Table 2. Data Output Rate vs. CLK, Filter Select, and Modulator Frequency Bits

CLKIN FREQ.	CLKIN FREQ.	CLK	MF1	MF0	AVAILABLE OUTPUT DATA RATES			
					FS1, FS0 (0, 0) (sps)*	FS1, FS0 (0, 1) (sps)*	FS1, FS0 (1, 0) (sps)	FS1, FS0 (1, 1) (sps)
X2CLK = 0 fCLKIN (MHz)	X2CLK = 1 fCLKIN (MHz)							
1.024	2.048	0	0	0	20	25	100	200
1.024	2.048	0	0	1	40	50	200	400
1.024	2.048	0	1	0	80	100	400	800
1.024	2.048	0	1	1	160	200	800	1600
2.4576	4.9152	1	0	0	50	60	300	600
2.4576	4.9152	1	0	1	100	120	600	1200
2.4576	4.9152	1	1	0	200	240	1200	2400
2.4576	4.9152	1	1	1	400	480	2400	4800

* Data rates offering noise-free 16-bit resolution.

Note: When FAST = 0, $f_{-3dB} = 0.262 \cdot \text{Data Rate}$. When FAST = 1, $f_{-3dB} = 0.443 \cdot \text{Data Rate}$.

Default condition is in bold print.

Table 3. Special Modes Controlled by M1, M0 (SCAN = 0)

M1	M0	DESCRIPTION
0	0	Normal Mode: The device operates normally.
0	1	Calibrate Offset: In this mode the MAX1402 converts the voltage applied across CALOFF+ and CALOFF-. The PGA gain, DAC, and format settings of the selected channel (defined by DIFF, A1, A0) are used.
1	0	Calibrate Gain: In this mode the MAX1402 converts the voltage applied across CALGAIN+ and CALGAIN-. The PGA gain, DAC, and format settings of the selected channel (defined by DIFF, A1, A0) are used.
1	1	Reserved: Do not use.

+5V, 18-Bit, Low-Power, Multichannel, Oversampling (Sigma-Delta) ADC

Table 4. SCAN Mode Scanning Sequences (SCAN = 1)

DIFF	M1	M0	SEQUENCE
0	0	0	AIN1–AIN6, AIN2–AIN6, AIN3–AIN6, AIN4–AIN6, AIN5–AIN6
0	0	1	AIN1–AIN6, AIN2–AIN6, AIN3–AIN6, AIN4–AIN6, AIN5–AIN6, CALOFF, CALGAIN
0	1	0	AIN1–AIN6, AIN2–AIN6, AIN3–AIN6, AIN4–AIN6, AIN5–AIN6, CALOFF, CALGAIN
1	0	0	AIN1–AIN2, AIN3–AIN4, AIN5–AIN6
1	0	1	AIN1–AIN2, AIN3–AIN4, AIN5–AIN6, CALOFF, CALGAIN
1	1	0	AIN1–AIN2, AIN3–AIN4, AIN5–AIN6, CALOFF, CALGAIN

Note: All other combinations reserved.

Table 5. Available Input Channels (SCAN = 0)

DIFF	M1	M0	AVAILABLE CHANNELS
0	0	0	AIN1–AIN6, AIN2–AIN6, AIN3–AIN6, AIN4–AIN6
0	0	1	CALOFF
0	1	0	CALGAIN
1	0	0	AIN1–AIN2, AIN3–AIN4, AIN5–AIN6
1	0	1	CALOFF
1	1	0	CALGAIN

Special Function Register (Write-Only)

MDOUT: (Default = 0) Modulator Out Bit. MDOUT = 0 enables data readout on the DOUT pin, the normal condition for the serial interface. MDOUT = 1 changes the function of the DOUT and $\overline{\text{INT}}$ pins, providing raw, single-bit modulator output instead of the normal serial-data interface output. This allows custom filtering directly on the modulator output, without going through the on-chip digital filter. The $\overline{\text{INT}}$ pin provides a clock to indicate when the modulator data at DOUT should be sampled (falling edge of $\overline{\text{INT}}$). Note that in this mode, the on-chip digital filter continues to operate normally. When MDOUT is returned to 0, valid data may be accessed through the normal serial-interface read operation.

FULLPD: (Default = 0) Complete Power-Down Bit. FULLPD = 1 forces the part into a complete power-down condition, which includes the clock oscillator. The serial interface continues to operate. The part requires a hardware reset to recover correctly from this condition.

Note: Changing the reserved bits in the special-function register from the default status of all 0s will select one of the reserved modes and the part will not operate as expected. This register is a write-only register. However, in the event that this register is mistakenly read, clock 24 bits of data out of the part to restore it to the normal interface-idle state.

Transfer-Function Registers

The three transfer-function registers control the method used to map the input voltage to the output codes. All of the registers have the same format. The mapping of control registers to associated channels depends on the mode of operation and is affected by the state of M1, M0, DIFF, and SCAN (Tables 8, 9, and 10).

Special Function Register (Write-Only)

FUNCTION	First Bit (MSB)			MDOUT	RESERVED BITS				(LSB)
	RESERVED BITS	RESERVED BITS	RESERVED BITS		RESERVED BITS	RESERVED BITS	RESERVED BITS	RESERVED BITS	FULLPD
Name	0	0	0	MDOUT	0	0	0	0	FULLPD
Defaults	0	0	0	0	0	0	0	0	0

Transfer-Function Register

FUNCTION	First Bit (MSB)				(LSB)			
	PGA GAIN CONTROL				OFFSET CORRECTION			
Name	G2	G1	G0	U/\overline{B}	D3	D2	D1	D0
Defaults	0	0	0	0	0	0	0	0

+5V, 18-Bit, Low-Power, Multichannel, Oversampling (Sigma-Delta) ADC

Analog Inputs AIN1 to AIN6

Inputs AIN1 and AIN2 map to transfer-function register 1, regardless of scanning mode (SCAN = 1) or single-ended vs. differential (DIFF) modes. Likewise, AIN3 and AIN4 inputs always map to transfer-function register 2. Finally, AIN5 always maps to transfer-function register 3 (input AIN6 is analog common).

CALGAIN and CALOFF

When not in scan mode (SCAN = 0), A1 and A0 select which transfer function applies to CALGAIN and CALOFF. In scan mode (SCAN = 1), CALGAIN and CALOFF are always mapped to transfer-function register 3. Note that when scanning while $M1 \neq M0$, the scan sequence includes both CALGAIN and CALOFF channels (Table 4). CALOFF always precedes CALGAIN, even though both channels share the same channel ID tag (Table 11).

Note that changing the status of any **active** channel control bits will cause \overline{INT} to immediately transition high and the modulator/filter to be reset. \overline{INT} will reassert after the appropriate digital-filter settling time. The control settings of the inactive channels may be changed freely without affecting the status of \overline{INT} or causing the filter/modulator to be reset.

PGA Gain

Bits G2–G0 control the PGA gain according to Table 6.

Unipolar/Bipolar Mode

The U/\overline{B} bit places the channel in either bipolar or unipolar mode. A 0 selects bipolar mode, and a 1 selects unipolar mode. This bit does not affect the analog-signal conditioning. The modulator always accepts bipolar inputs and produces a bitstream with 50% ones-density when the selected inputs are at the same potential. This bit controls the processing of the digital-filter output, such that the available output bits are

Table 6. PGA Gain Codes

G2	G1	G0	PGA GAIN
0	0	0	x1
0	0	1	x2
0	1	0	x4
0	1	1	x8
1	0	0	x16
1	0	1	x32
1	1	0	x64
1	1	1	x128

mapped to the correct output range. Note U/\overline{B} must be set before a conversion is performed; it will not affect any data already held in the output register.

Selecting bipolar mode does not imply that any input may be taken below AGND. It simply changes the gain and offset of the part. All inputs must remain within their specified operating voltage range.

Offset-Correction DACs

Bits D3–D0 control the offset-correction DAC. The DAC range depends on the PGA gain setting and is expressed as a percentage of the available full-scale input range (Table 7).

D3 is a sign bit, and D2–D0 represent the DAC magnitude. Note that when a DAC value of 0000 is programmed (the default), the DAC is disconnected from the modulator inputs. This prevents the DAC from degrading noise performance when offset correction is not required.

Transfer-Function Register Mapping

Tables 8, 9, and 10 show the channel-control register mapping in the various operating modes.

Table 7. DAC Code vs. DAC Value

D3	D2	D1	D0	BIPOLAR DAC VALUE (% of FSR)	UNIPOLAR DAC VALUE (% of FSR)
0	0	0	0	DAC not connected	
0	0	0	1	+8.3	+16.7
0	0	1	0	+16.7	+33.3
0	0	1	1	+25	+50
0	1	0	0	+33.3	+66.7
0	1	0	1	+41.6	+83.3
0	1	1	0	+50	+100
0	1	1	1	+58.3	+116.7
1	0	0	0	DAC not connected	
1	0	0	1	-8.3	-16.7
1	0	1	0	-16.7	-33.3
1	0	1	1	-25	-50
1	1	0	0	-33.3	-66.7
1	1	0	1	-41.6	-83.3
1	1	1	0	-50	-100
1	1	1	1	-58.3	-116.7

+5V, 18-Bit, Low-Power, Multichannel, Oversampling (Sigma-Delta) ADC

Table 8. Transfer-Function Register Mapping—Normal Mode (M1 = 0, M0 = 0)

SCAN	DIFF	A1	A0	CHANNEL	TRANSFER FUNCTION REG.
0	0	0	0	AIN1–AIN6	1
0	0	0	1	AIN2–AIN6	1
0	0	1	0	AIN3–AIN6	2
0	0	1	1	AIN4–AIN6	2
0	1	0	0	AIN1–AIN2	1
0	1	0	1	AIN3–AIN4	2
0	1	1	0	AIN5–AIN6	3
0	1	1	1	Do Not Use	
1	0	X	X	AIN1–AIN6	1
1	0	X	X	AIN2–AIN6	1
1	0	X	X	AIN3–AIN6	2
1	0	X	X	AIN4–AIN6	2
1	0	X	X	AIN5–AIN6	3
1	1	X	X	AIN1–AIN2	1
1	1	X	X	AIN3–AIN4	2
1	1	X	X	AIN5–AIN6	3
1	1	1	1	Do Not Use	

X = Don't care

+5V, 18-Bit, Low-Power, Multichannel, Oversampling (Sigma-Delta) ADC

MAX1402

Table 9. Transfer-Function Register Mapping—Offset-Cal Mode (M1 = 0, M0 = 1)

SCAN	DIFF	A1	A0	CHANNEL	TRANSFER FUNCTION REG.
0	0	0	0	CALOFF+–CALOFF-	1
0	0	0	1	CALOFF+–CALOFF-	1
0	0	1	0	CALOFF+–CALOFF-	2
0	0	1	1	CALOFF+–CALOFF-	2
0	1	0	0	CALOFF+–CALOFF-	1
0	1	0	1	CALOFF+–CALOFF-	2
0	1	1	0	CALOFF+–CALOFF-	3
0	1	1	1	Do Not Use	
1	0	X	X	AIN1–AIN6	1
1	0	X	X	AIN2–AIN6	1
1	0	X	X	AIN3–AIN6	2
1	0	X	X	AIN4–AIN6	2
1	0	X	X	AIN5–AIN6	3
1	0	X	X	CALOFF+–CALOFF-	3
1	0	X	X	CALGAIN+–CALGAIN-	3
1	1	X	X	AIN1–AIN2	1
1	1	X	X	AIN3–AIN4	2
1	1	X	X	AIN5–AIN6	3
1	1	X	X	CALOFF+ – CALOFF-	3
1	1	X	X	CALGAIN+ – CALGAIN-	3
1	1	1	1	Do Not Use	

X = Don't care

+5V, 18-Bit, Low-Power, Multichannel, Oversampling (Sigma-Delta) ADC

Table 10. Transfer-Function Register Mapping—Gain-Cal Mode (M1 = 1, M0 = 0)

SCAN	DIFF	A1	A0	CHANNEL	TRANSFER FUNCTION REG.
0	0	0	0	CALGAIN+–CALGAIN-	1
0	0	0	1	CALGAIN+–CALGAIN-	1
0	0	1	0	CALGAIN+–CALGAIN-	2
0	0	1	1	CALGAIN+–CALGAIN-	2
0	1	0	0	CALGAIN+–CALGAIN-	1
0	1	0	1	CALGAIN+–CALGAIN-	2
0	1	1	0	CALGAIN+–CALGAIN-	3
0	1	1	1	Do Not Use	
1	0	X	X	AIN1–AIN6	1
1	0	X	X	AIN2–AIN6	1
1	0	X	X	AIN3–AIN6	2
1	0	X	X	AIN4–AIN6	2
1	0	X	X	AIN5–AIN6	3
1	0	X	X	CALOFF+–CALOFF-	3
1	0	X	X	CALGAIN+–CALGAIN-	3
1	1	X	X	AIN1–AIN2	1
1	1	X	X	AIN3–AIN4	2
1	1	X	X	AIN5–AIN6	3
1	1	X	X	CALOFF+ – CALOFF-	3
1	1	X	X	CALGAIN+ – CALGAIN-	3
1	1	1	1	Do Not Use	

X = Don't care

Data Register (Read-Only)

The data register is a 24-bit, read-only register. Any attempt to write data to this location will have no effect. If a write operation is attempted, 8 bits of data must be clocked into the part before it will return to its normal idle mode, expecting a write to the communications register.

Data is output MSB first, followed by one reserved 0 bit, two auxiliary data bits, and a 3-bit channel ID tag indicating the channel from which the data originated.

Data Register (Read-Only) Bits

First Bit (Data MSB)

DATA BITS							
D17	D16	D15	D14	D13	D12	D11	D10

DATA BITS							
D9	D8	D7	D6	D5	D4	D3	D2

(Data LSB)

(LSB)

DATA BITS		RESERVED	AUXILIARY DATA		CHANNEL ID TAG		
D1	D0	'0'	DS1	DS0	CID2	CID1	CID0

D17–D0: The conversion result. D17 is the MSB. The result is in offset binary format. 00 0000 0000 0000 represents the minimum value and 11 1111 1111 1111 represents the maximum value. Inputs exceeding the available input range are limited to the corresponding minimum or maximum output values.

0: This reserved bit will always be 0.

+5V, 18-Bit, Low-Power, Multichannel, Oversampling (Sigma-Delta) ADC

DS1, DS0: The status of the auxiliary data input pins. These are latched on the first falling edge of the SCLK signal for the current data register read access.

CID2–0: Channel ID tag (Table 11).

Switching Network

A switching network provides selection between three fully differential input channels or five pseudo-differential channels, using AIN6 as a shared common. The switching network provides two additional fully differential input channels intended for system calibration, which may be used as extra fully differential signal channels. Table 12 shows the channel configurations available for both operating modes.

Table 11. Channel ID Tag Codes

CID2	CID1	CID0	CHANNEL
0	0	0	AIN1–AIN6
0	0	1	AIN2–AIN6
0	1	0	AIN3–AIN6
0	1	1	AIN4–AIN6
1	0	0	AIN1–AIN2
1	0	1	AIN3–AIN4
1	1	0	AIN5–AIN6
1	1	1	Calibration

Table 12. Input Channel Configuration in Fully and Pseudo-Differential Modes (SCAN = 0)

M1	M0	DIFF	A1	A0	MODE	HIGH INPUT	LOW INPUT
0	0	0	0	0	Pseudo-Differential	AIN1	AIN6
0	0	0	0	1		AIN2	AIN6
0	0	0	1	0		AIN3	AIN6
0	0	0	1	1		AIN4	AIN6
0	0	X	X	X		AIN5*	AIN6*
0	1	X	X	X		CALOFF+**	CALOFF-**
1	0	X	X	X		CALGAIN+**	CALGAIN-**
0	0	1	0	0		Fully Differential	AIN1
0	0	1	0	1	AIN3		AIN4
0	0	1	1	0	AIN5		AIN6
0	1	X	X	X	CALOFF+**		CALOFF-**
1	0	X	X	X	CALGAIN+**		CALGAIN-**
0	0	0	0	0			

X = Don't care

* This combination is available only in pseudo-differential mode when using the internal scanning logic

** These combinations are only available in the calibration modes.

Scanning (SCAN-Mode)

To sample and convert the available input channels sequentially, set the SCAN control bit in the global setup register. The sequence is determined by DIFF (fully differential or pseudo-differential) and by the mode control bits M1 and M0 (Tables 8, 9, 10). With SCAN set, the part automatically sequences through each available channel, transmitting a single conversion result before proceeding to the next channel. The MAX1402 automatically allows sufficient time for each conversion to fully settle, to ensure optimum resolution before asserting the data-ready signal and moving to the next available channel. The scan rate is, therefore, dependent on the clock bit (CLK), the filter control bits (FS1, FS0), and the modulator frequency selection bits (MF1, MF0).

Burn-Out Currents

The input circuitry also provides two “burn-out” currents. These small currents may be used to test the integrity of the selected transducer. They can be selectively enabled or disabled by the BOUT bit in the global setup register.

Transducer Excitation Currents

The MAX1402 provides two matched 200µA transducer excitation currents at OUT1 and OUT2. These currents

+5V, 18-Bit, Low-Power, Multichannel, Oversampling (Sigma-Delta) ADC

have low absolute temperature coefficients and tight TC matching. Optimized for transducer excitation, the current sources possess tight temperature tracking allowing accurate compensation of errors due to IR drops in long transducer cable runs. They may be enabled or disabled using a single register control bit (IOUT).

Dynamic Input Impedance at the Channel Selection Network

When used in unbuffered mode (BUFF = 0), the analog inputs present a dynamic load to the driving circuitry. The size of the sampling capacitor and the input sampling frequency (Figure 5) determine the dynamic load seen by the driving circuitry. The MAX1402 samples at a constant rate for all gain settings. This provides a maximum time for the input to settle at a given data rate. The dynamic load presented by the inputs varies with the gain setting. For gains of +2V/V, +4V/V, and +8V/V, the input sampling capacitor increases with the chosen gain. Gains of +16V/V, +32V/V, +64V/V, and +128V/V present the same input load as the x8 gain setting.

When designing with the MAX1402, as with any other switched-capacitor ADC input, consider the advantages and disadvantages of series input resistance. A series resistor reduces the transient-current impulse to the external driving amplifier. This improves the amplifier phase margin and reduces the possibility of ringing.

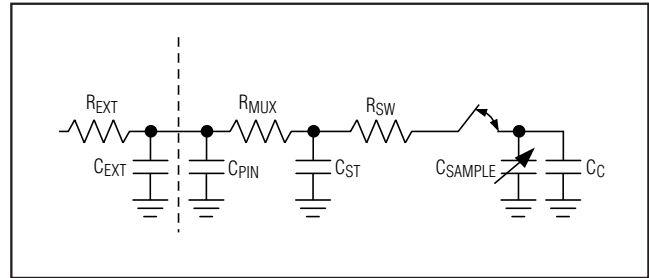

Figure 5. Analog Input, Unbuffered Mode (BUFF = 0)

The resistor spreads the transient-load current from the sampler over time due to the RC time constant of the circuit. However, an improperly chosen series resistance can hinder performance in fast 16-bit converters. The settling time of the RC network can limit the speed at which the converter can operate properly, or reduce the settling accuracy of the sampler. In practice, this means ensuring that the RC time constant—resulting from the product of the driving source impedance and the capacitance presented by both the MAX1402's input and any external capacitances—is sufficiently small to allow settling to the desired accuracy. Tables 13a–13d summarize the maximum allowable series resistance vs. external capacitance for each MAX1402 gain setting in order to ensure 16-bit performance in unbuffered mode.

Table 13a. R_{EXT}, C_{EXT} Values for Less than 16-Bit Gain Error in Unbuffered (BUFF = 0) Mode—1x Modulator Sampling Frequency (MF1, MF0 = 00); X2CLK = 0; CLKIN = 2.4576MHz

PGA GAIN	EXTERNAL RESISTANCE R _{EXT} (kΩ)					
	C _{EXT} = 0pF	C _{EXT} = 50pF	C _{EXT} = 100pF	C _{EXT} = 50pF	C _{EXT} = 1000pF	C _{EXT} = 5000pF
1	45	20	13	3.9	2.2	0.58
2	45	20	13	3.9	2.2	0.58
4	34	17	12	3.6	2.0	0.53
8, 16, 32, 64, 128	22	13	9.7	3.3	1.9	0.49

Table 13b. R_{EXT}, C_{EXT} Values for Less than 16-Bit Gain Error in Unbuffered (BUFF = 0) Mode—2x Modulator Sampling Frequency (MF1, MF0 = 01); X2CLK = 0; CLKIN = 2.4576MHz

PGA GAIN	EXTERNAL RESISTANCE R _{EXT} (kΩ)					
	C _{EXT} = 0pF	C _{EXT} = 50pF	C _{EXT} = 100pF	C _{EXT} = 50pF	C _{EXT} = 1000pF	C _{EXT} = 5000pF
1	23	9.9	6.5	1.9	1.1	0.29
2	23	9.9	6.5	1.9	1.1	0.29
4	17	8.5	5.8	1.8	1.0	0.27
8, 16, 32, 64, 128	11.2	6.7	4.9	1.6	0.93	0.24

+5V, 18-Bit, Low-Power, Multichannel, Oversampling (Sigma-Delta) ADC

Table 13c. R_{EXT}, C_{EXT} Values for Less than 16-Bit Gain Error in Unbuffered (BUFF = 0) Mode—4x Modulator Sampling Frequency (MF1, MF0 = 10); X2CLK = 0; CLKIN = 2.4576MHz

PGA GAIN	EXTERNAL RESISTANCE R _{EXT} (kΩ)					
	C _{EXT} = 0pF	C _{EXT} = 50pF	C _{EXT} = 100pF	C _{EXT} = 500pF	C _{EXT} = 1000pF	C _{EXT} = 5000pF
1	11.1	4.9	3.2	0.95	0.54	0.14
2	11.1	4.9	3.2	0.95	0.54	0.14
4	8.3	4.2	2.9	0.89	0.50	0.13
8, 16, 32, 64, 128	5.5	3.3	2.4	0.81	0.46	0.12

Table 13d. R_{EXT}, C_{EXT} Values for Less than 16-Bit Gain Error in Unbuffered (BUFF = 0) Mode—8x Modulator Sampling Frequency (MF1, MF0 = 11); X2CLK = 0; CLKIN = 2.4576MHz

PGA GAIN	EXTERNAL RESISTANCE R _{EXT} (kΩ)					
	C _{EXT} = 0pF	C _{EXT} = 50pF	C _{EXT} = 100pF	C _{EXT} = 500pF	C _{EXT} = 1000pF	C _{EXT} = 5000pF
1	5.4	2.4	1.6	0.47	0.26	0.069
2	5.4	2.4	1.6	0.47	0.26	0.069
4	4.0	2.1	1.4	0.43	0.25	0.064
8, 16, 32, 64, 128	2.7	1.6	1.2	0.39	0.23	0.059

Input Buffers

The MAX1402 provides a pair of input buffers to isolate the inputs from the capacitive load presented by the PGA/modulator (Figure 6). The buffers are chopper stabilized to reduce the effect of their DC offsets and low-frequency noise. Since the buffers can represent more than 50% of the total analog power dissipation, they may be shut down in applications where minimum power dissipation is required and the capacitive input load is not a concern. Disable the buffers in applications where the inputs must operate close to AGND or V+.

When used in buffered mode, the buffers isolate the inputs from the sampling capacitors. The sampling-related gain error is dramatically reduced in this mode. A small dynamic load remains from the chopper stabilization. The multiplexer exhibits a small input leakage current of up to 10nA. With high source resistances, this leakage current may result in a DC offset.

Reference Input

The MAX1402 is optimized for ratiometric measurements and includes a fully differential reference input. Apply the reference voltage across REFIN+ and REFIN-

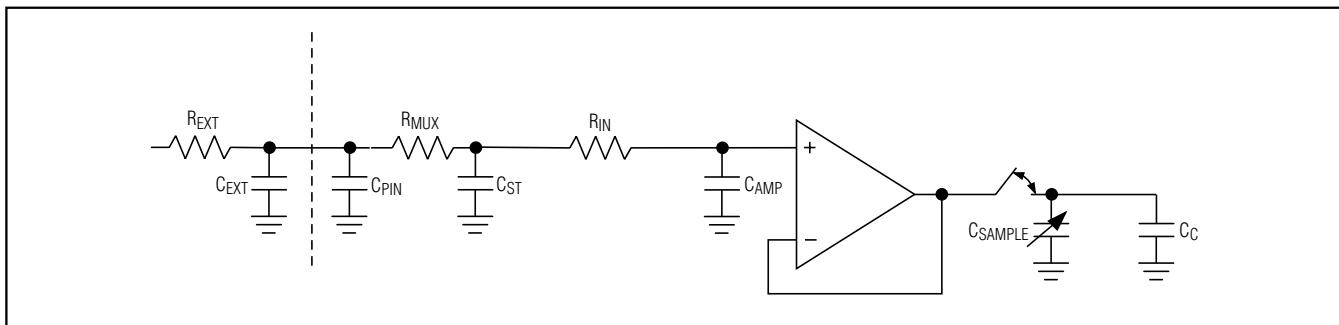

Figure 6. Analog Input, Buffered Mode (BUFF = 1)

+5V, 18-Bit, Low-Power, Multichannel, Oversampling (Sigma-Delta) ADC

Table 14. R_{EXT}, C_{EXT} Values for Less than 16-Bit Gain Error in Buffered (BUFF = 1) Mode—All Modulator Sampling Frequencies (MF1, MF0 = XX); X2CLK = 0; CLKIN = 2.4576MHz

PGA GAIN	EXTERNAL RESISTANCE R _{EXT} (kΩ)					
	C _{EXT} = 0pF	C _{EXT} = 50pF	C _{EXT} = 100pF	C _{EXT} = 500pF	C _{EXT} = 1000pF	C _{EXT} = 5000pF
1	10	10	10	10	10	10
2	10	10	10	10	10	10
4	10	10	10	10	10	10
8	10	10	10	10	10	10
16	10	10	10	10	10	10
32	10	10	10	10	10	10
64	10	10	10	10	10	10
128	10	10	10	10	10	10

ensuring that REFIN+ is more positive than REFIN-. REFIN+ and REFIN- must be between AGND and V+. The MAX1402 is specified with a +2.5V reference when operating with a +5V analog supply (V+).

Modulator

The MAX1402 performs analog-to-digital conversion using a single-bit, second-order, switched-capacitor modulator. A single comparator within the modulator quantizes the input signal at a much higher sample rate than the bandwidth of the signal to be converted. The quantizer then presents a stream of 1s and 0s to the digital filter for processing, to remove the frequency-shaped quantization noise.

The MAX1402 modulator provides 2nd-order frequency shaping of the quantization noise resulting from the single bit quantizer. The modulator is fully differential for maximum signal-to-noise ratio and minimum susceptibility to power-supply noise.

The modulator operates at one of a total of eight different sampling rates (f_M) determined by the master clock frequency (f_{CLKIN}), the X2CLK bit, the CLK bit, and the modulator frequency control bits MF1 and MF0. Power dissipation is optimized for each of these modes by controlling the bias level of the modulator. Table 15 shows the input and reference sample rates.

PGA

A programmable gain amplifier (PGA) with a user-selectable gain of x1, x2, x4, x8, x16, x32, x64, or x128 (Table 6) precedes the modulator. Figure 7 shows the default bipolar transfer function with the following illustrated codes: 1) PGA = 0, DAC = 0; 2) PGA = 3, DAC = 0; or 3) PGA = 3, DAC = 3.

Output Noise

Tables 16a and 16b show the rms noise for typical output frequencies (notches) and -3dB frequencies for the MAX1402 with f_{CLKIN} = 2.4576MHz. The numbers given are for the bipolar input ranges with V_{REF} = +2.50V, with no buffer (BUFF = 0) and with the buffer inserted (BUFF = 1). These numbers are typical and are generated at a differential analog input voltage of 0. Figure 8 shows graphs of Effective Resolution vs. Gain and Notch Frequency. The effective resolution values were derived from the following equation:

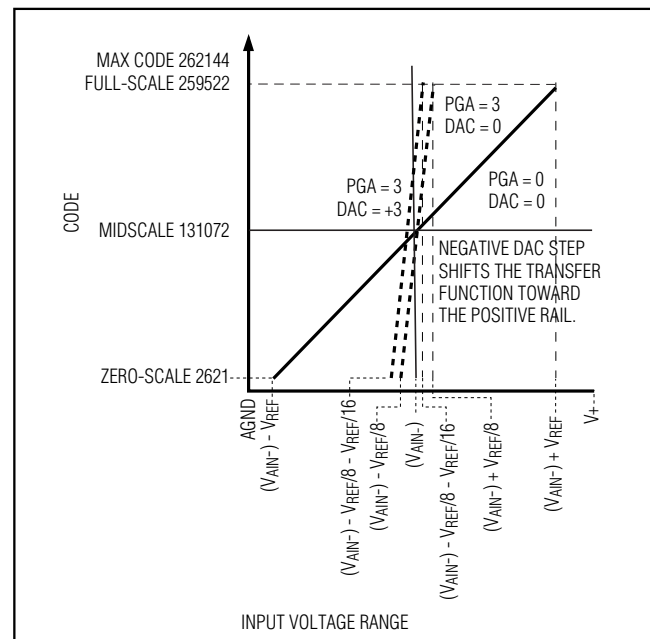

Figure 7. Effect of PGA and DAC Codes on the Bipolar Transfer Function

+5V, 18-Bit, Low-Power, Multichannel, Oversampling (Sigma-Delta) ADC

MAX1402

Table 15. Modulator Operating Frequency, Sampling Frequency, and 16-Bit Data Output Rates

MCLK FREQ. X2CLK = 0 DEFAULT f _{CLKIN} (MHz)	MCLK FREQ. X2CLK = 1 f _{CLKIN} (MHz)	CLK	MF1	MF0	AIN/REFIN SAMPLING FREQ. f _s (kHz)	MOD. FREQ. f _M (kHz)	AVAILABLE OUTPUT DATA RATES AT 16-BIT ACCURACY (sps)
1.024	2.048	0	0	0	16	8	20, 25
1.024	2.048	0	0	1	32	16	40, 50
1.024	2.048	0	1	0	64	32	80, 100
1.024	2.048	0	1	1	128	64	160, 200
2.4576	4.9152	1	0	0	38.4	19.2	50, 60
2.4576	4.9152	1	0	1	76.8	38.4	100, 120
2.4576	4.9152	1	1	0	153.6	76.8	200, 240
2.4576	4.9152	1	1	1	307.2	153.6	400, 480

Note: Default condition is in bold print.

**Table 16a. MAX1402 Noise vs. Gain and Output Data Rate—Unbuffered Mode,
V_{REF} = 2.5V, f_{CLKIN} = 2.4576MHz**

OUTPUT DATA RATE (sps)	-3dB FREQ. (Hz)	TYPICAL OUTPUT NOISE IN μVRMS								BIT STATUS
		PROGRAMMABLE GAIN								
		x1	x2	x4	x8	x16	x32	x64	x128	
										MF1:MF0 = 0
50	13.1	6.20	3.27	2.02	1.25	1.13	1.10	1.05	0.99	FS1:FS0 = 0
60	15.7	7.23	3.94	2.21	1.36	1.20	1.12	1.10	1.10	FS1:FS0 = 1
300	78.6	147.60	70.73	35.10	17.91	9.57	5.05	3.54	2.75	FS1:FS0 = 2
600	157.2	844.82	417.07	216.88	107.06	50.91	26.25	13.26	7.43	FS1:FS0 = 3
										MF1:MF0 = 1
100	26.2	6.98	3.61	1.94	1.24	1.10	1.04	0.98	1.00	FS1:FS0 = 0
120	31.4	7.91	3.93	2.14	1.36	1.17	1.08	1.08	1.10	FS1:FS0 = 1
600	157.2	138.79	73.86	37.69	19.19	9.34	5.15	3.29	2.76	FS1:FS0 = 2
1200	314.4	836.32	405.49	203.35	99.75	52.38	24.50	13.40	7.31	FS1:FS0 = 3
										MF1:MF0 = 2
200	52.4	6.25	4.00	1.96	1.26	1.07	1.02	0.98	1.01	FS1:FS0 = 0
240	62.9	7.00	4.16	2.04	1.34	1.15	1.14	1.09	1.09	FS1:FS0 = 1
1200	314.4	141.69	71.25	35.91	18.11	9.45	5.20	3.38	2.79	FS1:FS0 = 2
2400	628.8	816.66	399.44	200.51	103.04	51.17	26.57	13.88	7.38	FS1:FS0 = 3
										MF1:MF0 = 3
400	104.8	6.87	3.50	2.06	1.31	1.16	1.09	1.13	1.08	FS1:FS0 = 0
480	125.7	8.15	3.84	2.36	1.44	1.28	1.23	1.22	1.21	FS1:FS0 = 1
2400	628.8	150.09	69.17	36.54	18.92	9.67	5.14	3.61	3.12	FS1:FS0 = 2
4800	1258	820.73	419.17	203.74	103.78	51.42	26.47	13.96	7.68	FS1:FS0 = 3

+5V, 18-Bit, Low-Power, Multichannel, Oversampling (Sigma-Delta) ADC

Table 16b. MAX1402 Noise vs. Gain and Output Data Rate—Buffered Mode, VREF = 2.5V, fCLKIN = 2.4576MHz

OUTPUT DATA RATE (sps)	-3dB FREQ. (Hz)	TYPICAL OUTPUT NOISE IN μVRMS								BIT STATUS
		PROGRAMMABLE GAIN								
		x1	x2	x4	x8	x16	x32	x64	x128	
										MF1:MF0 = 0
50	13.1	6.05	4.13	2.35	1.50	1.40	1.32	1.37	1.39	FS1:FS0 = 0
60	15.7	7.11	4.24	2.54	1.64	1.49	1.53	1.49	1.48	FS1:FS0 = 1
300	78.6	142.02	71.62	35.65	18.32	9.35	5.60	4.10	3.52	FS1:FS0 = 2
600	157.2	823.33	405.95	195.95	102.14	50.28	25.85	13.75	7.78	FS1:FS0 = 3
										MF1:MF0 = 1
100	26.2	8.10	3.66	2.25	1.52	1.34	1.31	1.34	1.35	FS1:FS0 = 0
120	31.4	8.37	4.12	2.53	1.64	1.45	1.49	1.45	1.46	FS1:FS0 = 1
600	157.2	143.45	69.52	36.04	17.77	9.32	5.48	3.92	3.41	FS1:FS0 = 2
1200	314.4	830.30	408.48	201.87	101.39	52.39	26.77	13.50	7.87	FS1:FS0 = 3
										MF1:MF0 = 2
200	52.4	6.55	3.21	1.92	1.35	1.24	1.16	1.16	1.10	FS1:FS0 = 0
240	62.9	7.40	3.89	2.24	1.47	1.35	1.29	1.22	1.25	FS1:FS0 = 1
1200	314.4	148.57	73.71	36.80	18.08	9.92	5.26	3.64	3.02	FS1:FS0 = 2
2400	628.8	851.32	408.09	202.57	105.18	52.98	25.71	13.33	7.97	FS1:FS0 = 3
										MF1:MF0 = 3
400	104.8	6.60	3.83	2.21	1.38	1.28	1.21	1.17	1.21	FS1:FS0 = 0
480	125.7	7.58	4.14	2.28	1.58	1.40	1.34	1.30	1.31	FS1:FS0 = 1
2400	628.8	144.96	68.92	35.92	17.36	9.52	5.45	3.79	3.21	FS1:FS0 = 2
4800	1258	803.87	394.00	205.60	102.18	52.48	26.07	13.59	7.89	FS1:FS0 = 3

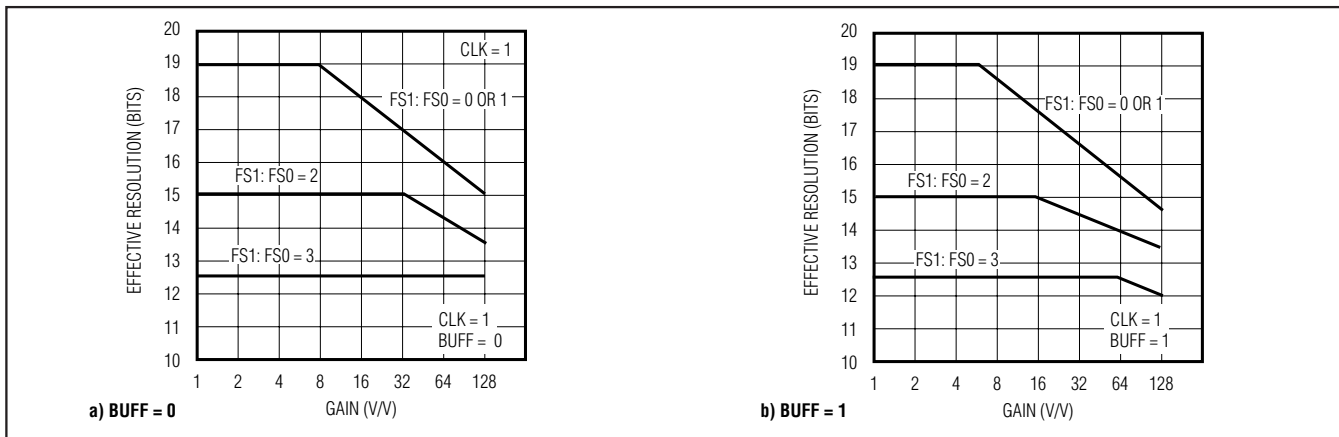

Figure 8. Effective Resolution vs. Gain and Notch Frequency

$$\text{Effective Resolution} = (\text{SNR}_{\text{dB}} - 1.76\text{dB}) / 6.02$$

The maximum possible signal divided by the noise of the device, SNR_{dB} , is defined as the ratio of the input full-scale voltage (i.e., $2 \cdot \text{VREFIN} / \text{GAIN}$) to the output rms noise. Note that it is not calculated using peak-to-

peak output noise numbers. Peak-to-peak noise numbers can be up to 6.6 times the rms numbers, while effective resolution numbers based on peak-to-peak noise can be 2.5 bits below the effective resolution based on rms noise, as quoted in the tables.

+5V, 18-Bit, Low-Power, Multichannel, Oversampling (Sigma-Delta) ADC

The noise shown in Table 16 is composed of device noise and quantization noise. The device noise is relatively low, but becomes the limiting noise source for high gain settings. The quantization noise is dependent on the notch frequency and becomes the dominant noise source as the notch frequency is increased.

Offset-Correction DAC

The MAX1402 provides a coarse (3-bit plus sign) offset-correction DAC at the modulator input. Use this DAC to remove the offset component in the input signal, allowing the ADC to operate on a more sensitive range. The DAC offsets up to $\pm 116.7\%$ of the selected range in $\pm 16.7\%$ increments for unipolar mode and up to $\pm 58.3\%$ of the selected range in $\pm 8.3\%$ increments for bipolar mode. When a DAC value of 0 is selected, the DAC is completely disconnected from the modulator inputs and does not contribute any noise. Figures 7 and 9 show the effect of the DAC codes on the input range and transfer function.

Clock Oscillator

The clock oscillator may be used with an external crystal (or resonator) connected between CLKIN and CLKOUT, or may be driven directly by an external oscillator at CLKIN with CLKOUT left unconnected. In normal operating mode, the MAX1402 is specified for operation with CLKIN at either 1.024MHz (CLK = 0) or 2.4576MHz (CLK = 1, default). When operated at these frequencies, the part may be programmed to produce frequency response nulls at the local line frequency (either 60Hz or 50Hz) and the associated line harmonics.

In standby mode (STBY = 1) all circuitry, with the exception of the serial interface and the clock oscillator, is powered down. The interface consumes minimal power with a static SCLK. Enter power-down mode (including the oscillator) by setting the FULLPD bit in the special-function register. When exiting a full-power shutdown, perform a hardware reset or a software reset after the master clock signal is established (typically 10ms when using the on-board oscillator with an external crystal) to ensure that any potentially corrupted registers are cleared.

It is often helpful to use higher-frequency crystals or resonators, especially for surface-mount applications where the result may be reduced PC board area for the oscillator component and a lower price or better component availability. Also, it may be necessary to operate the part with a clock source whose duty cycle is not close to 50%. In either case, the MAX1402 can operate with a master clock frequency of up to 5MHz, and includes an internal divide-by-2 prescaler to restore the internal clock frequency to a range of up to 2.5MHz

with a 50% duty cycle. To activate this prescaler, set the X2CLK bit in the control registers. Note that using CLKIN frequencies above 2.5MHz in combination with the X2CLK mode will result in a small increase in digital supply current.

Digital Filter

The on-chip digital filter processes the 1-bit data stream from the modulator using a SINC³ or SINC¹ filter. The SINC filters are conceptually simple, efficient, and extremely flexible, especially where variable resolution and data rates are required. Also, the filter notch positions are easily controlled, since they are directly related to the output data rate (1 / data word period).

The SINC¹ function results in a faster settling response while retaining the same frequency response notches as the default SINC³ filter. This allows the filter to settle faster at the expense of resolution and quantization noise. The SINC¹ filter settles in one data word period. With 60Hz notches (60Hz data rate), the settling time would be 1 / 60Hz or 16.7ms whereas the SINC³ filter would settle in 3 / 60Hz or 50ms. Toggle between these filter responses using the FAST bit in the global setup register. Use SINC¹ mode for faster settling and switch to SINC³ mode when full accuracy is required. Switch from the SINC¹ to SINC³ mode by resetting the FAST bit low. The DRDY signal will go false and will be reasserted

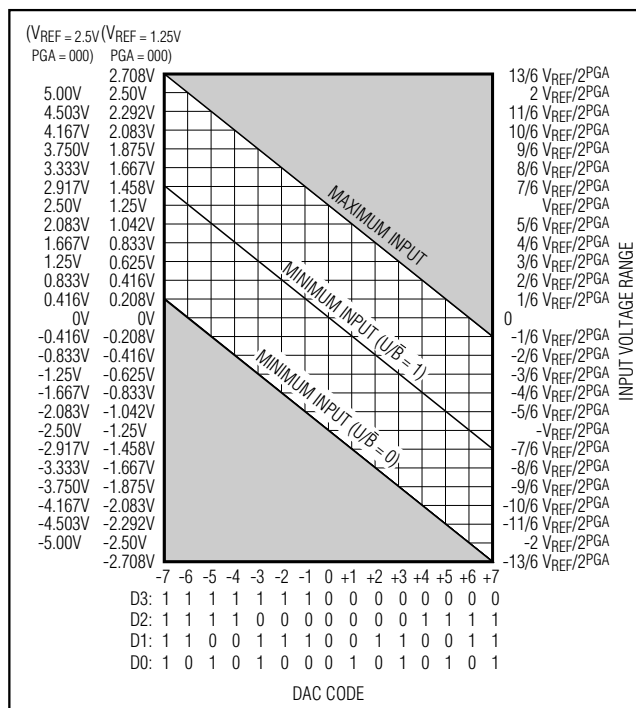

Figure 9. Input Voltage Range vs. DAC Code

+5V, 18-Bit, Low-Power, Multichannel, Oversampling (Sigma-Delta) ADC

when valid data is available, a minimum of three data-word periods later.

The digital filter can be bypassed by setting the MDOUT bit in the global setup register. When MDOUT = 1, the raw output of the modulator is directly available at DOUT.

Filter Characteristics

The MAX1402 digital filter implements both a SINC¹ (sinx/x) and SINC³ (sinx/x)³ lowpass filter function. The transfer function for the SINC³ function is that of three cascaded SINC¹ filters described in the z-domain by:

$$H(z) = \left[\frac{1}{N} \frac{1 - z^{-N}}{1 - z^{-1}} \right]^3$$

and in the frequency domain by:

$$H(f) = \left[\frac{1}{N} \frac{\sin\left(N\pi \frac{f}{f_M}\right)}{\sin\left(\pi \frac{f}{f_M}\right)} \right]^3$$

where N, the decimation factor, is the ratio of the modulator frequency f_M to the output frequency f_N .

Figure 10 shows the filter frequency response. The SINC³ characteristic cutoff frequency is 0.262 times the first notch frequency. This results in a cutoff frequency of 15.72Hz for a first filter notch frequency of 60Hz. The response shown in Figure 10 is repeated at either side of the digital filter's sample frequency (f_M) and at either side of the related harmonics ($2f_M$, $3f_M$, . . .).

The response of the SINC³ filter is similar to that of a SINC¹ (averaging filter) filter but with a sharper rolloff. The output data rate for the digital filter corresponds with the positioning of the first notch of the filter's frequency response. Therefore, for the plot of Figure 10 where the first notch of the filter is at 60Hz, the output data rate is 60Hz. The notches of this (sinx/x)³ filter are repeated at multiples of the first notch frequency. The SINC³ filter provides an attenuation of better than 100dB at these notches.

Determine the cutoff frequency of the digital filter by the value loaded into CLK, X2CLK, MF1, MF0, FS1, and FS0 in the global setup register. Programming a different cutoff frequency with FS0 and FS1 does not alter the profile of the filter response; it changes the frequency of the notches. For example, Figure 11 shows a cutoff frequency of 13.1Hz and a first notch frequency of 50Hz.

For step changes at the input, a settling time must be allowed before valid data can be read. The settling time depends upon the output data rate chosen for the filter. The settling time of the SINC³ filter to a full-scale step input can be up to four times the output data period. For a synchronized step input (using the FSYNC function or the internal scanning logic), the settling time is three-times the output data period.

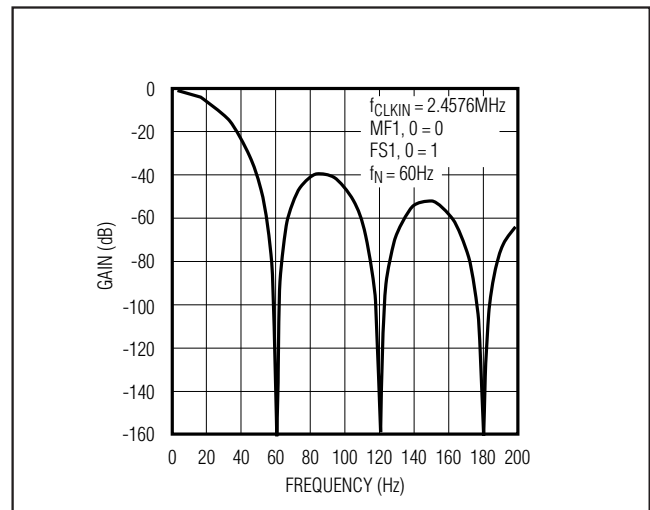

Figure 10. Frequency Response of the SINC³ Filter (Notch at 60Hz)

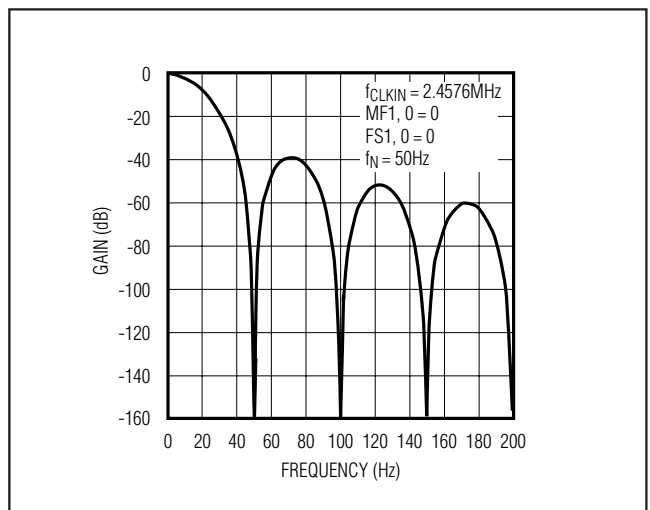

Figure 11. Frequency Response of the SINC³ Filter (Notch at 50Hz)

+5V, 18-Bit, Low-Power, Multichannel, Oversampling (Sigma-Delta) ADC

Analog Filtering

The digital filter does not provide any rejection close to the harmonics of the modulator sample frequency. However, due to the high oversampling ratio of the MAX1402, these bands occupy only a small fraction of the spectrum and most broadband noise is filtered. Therefore, the analog filtering requirements in front of the MAX1402 are considerably reduced compared to a conventional converter with no on-chip filtering. In addition, because the part's common-mode rejection of 90dB extends out to several kHz, common-mode noise susceptibility in this frequency range is substantially reduced.

Depending on the application, it may be necessary to provide filtering prior to the MAX1402 to eliminate unwanted frequencies the digital filter does not reject. It may also be necessary in some applications to provide additional filtering to ensure that differential noise signals outside the frequency band of interest do not saturate the analog modulator.

If passive components are placed in front of the MAX1402, when the part is used in unbuffered mode, ensure that the source impedance is low enough not to introduce gain errors in the system (Table 13). This can significantly limit the amount of passive anti-aliasing filtering that can be applied in front of the MAX1402 in unbuffered mode. However, when the part is used in buffered mode, large source impedances will simply result in a small DC offset error (a 1kΩ source resistance will cause an offset error of less than 10μV). Therefore, where any significant source impedances are required, Maxim recommends operating the part in buffered mode.

Calibration Channels

Two fully differential calibration channels allow measurement of the system gain and offset errors. Connect the CALOFF channel to 0V and the CALGAIN channel to the reference voltage. Average several measurements on both CALOFF and CALGAIN. Subtract the average offset code and scale to correct for the gain error. This linear calibration technique can be used to remove errors due to source impedances on the analog input (e.g., when using a simple RC anti-aliasing filter on the front end).

Applications Information

SPI Interface (68HC11, PIC16C73)

Microprocessors with a hardware SPI (serial peripheral interface) can use a 3-wire interface to the MAX1402 (Figure 12). The SPI hardware generates groups of eight pulses on SCLK, shifting data in on one pin and out on the other pin.

For best results, use a hardware interrupt to monitor the $\overline{\text{INT}}$ pin and acquire new data as soon as it is available. If hardware interrupts are not available, or if interrupt latency is longer than the selected conversion rate, use the FSYNC bit to prevent automatic measurement while reading the data output register.

The example code in Figure 13 shows how to interface with the MAX1402 using a 68HC11. System-dependent initialization code is not shown.

Bit-Banging Interface (80C51, PIC16C54)

Any microcontroller can use general-purpose I/O pins to interface to the MAX1402. If a bidirectional or open-drain I/O pin is available, reduce the interface pin count by connecting DIN to DOUT (Figure 14). Figure 15 shows how to emulate the SPI in software. Use the same initialization routine shown in Figure 13.

For best results, use a hardware interrupt to monitor the $\overline{\text{INT}}$ pin and acquire new data as soon as it is available. If hardware interrupts are not available, or if interrupt latency is longer than the selected conversion rate, use the FSYNC bit to prevent automatic measurement while reading the data output register.

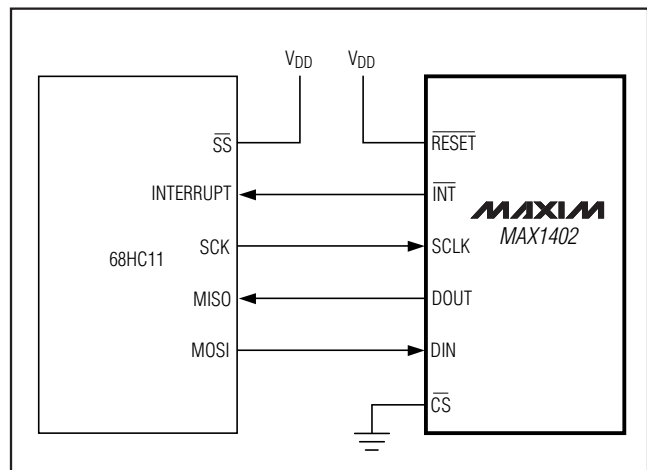

Figure 12. MAX1402 to 68HC11 Interface

+5V, 18-Bit, Low-Power, Multichannel, Oversampling (Sigma-Delta) ADC

```

/* Assumptions:
**   The MAX140X's CS pin is tied to ground
**   The MAX140X's INT pin drives a falling-edge-triggered interrupt
**   MAX140X's DIN is driven by MOSI, DOUT drives MISO, and SCLK drives SCLK
*/

/* Low-level function to write 8 bits using 68HC11 SPI */
void WriteByte (BYTE x)
{
    /* System-dependent: write to SPI hardware and wait until it is finished */
    HC11_SPDR = x;
    while (HC11_SPSR & HC11_SPSR_SPIF) { /* idle loop */ }
}

/* Low-level function to read 8 bits using 68HC11 SPI */
BYTE ReadByte (void)
{
    /* System-dependent: use SPI hardware to clock in 8 bits */
    HC11_SPDR = 0xFF;
    while (HC11_SPSR & HC11_SPSR_SPIF) { /* idle loop */ }
    return HC11_SPDR;
}

/* Low-level interrupt handler called whenever the MAX140X's INT pin goes low.
** This function reads new data from the MAX140X and feeds it into a
** user-defined function Process_Data().
*/
void HandleDRDY (void)
{
    BYTE data_H_bits, data_M_bits, data_L_bits; /* storage for data register */
    WriteByte(0x78); /* read the latest data register value */
    data_H_bits = ReadByte();
    data_M_bits = ReadByte();
    data_L_bits = ReadByte();
    Process_Data(data_H_bits, data_M_bits, data_L_bits);
    /* System-dependent: re-enable the interrupt service routine */
}

/* High-level function to configure the MAX140X's registers
** Refer to data sheet for custom setup values.
*/
void Initialize (void)
{
    /* System-dependent: configure the SPI hardware (CPOL=1,CPHA=1) */
    /* write to all of configuration registers */
    MY_GS1 = 0x0A; MY_GS2 = 0x00; MY_GS3 = 0x00;
    MY_TF1 = 0x00; MY_TF2 = 0x00; MY_TF3 = 0x00;
    WriteByte(0x10); WriteByte(MY_GS1); /* write Global Setup 1 */
    WriteByte(0x20); WriteByte(MY_GS2); /* write Global Setup 2 */
    WriteByte(0x30); WriteByte(MY_GS3); /* write Global Setup 3 */
    WriteByte(0x40); WriteByte(MY_TF1); /* write Transfer Function 1 */
    WriteByte(0x50); WriteByte(MY_TF2); /* write Transfer Function 2 */
    WriteByte(0x60); WriteByte(MY_TF3); /* write Transfer Function 3 */
    /* System-dependent: enable the data-ready (DRDY) interrupt handler */
}

```

Figure 13. Example SPI Interface

+5V, 18-Bit, Low-Power, Multichannel, Oversampling (Sigma-Delta) ADC

MAX1402

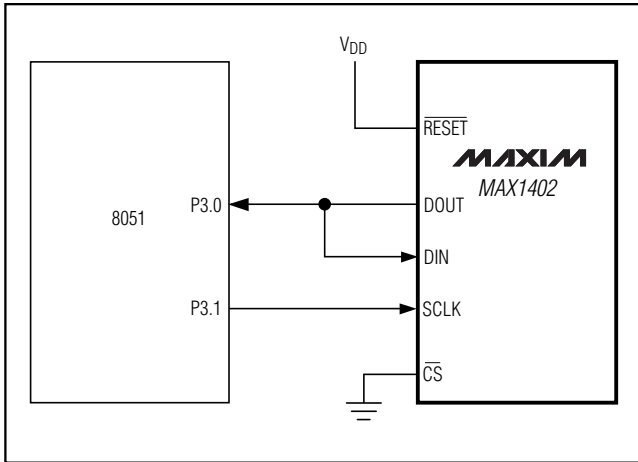

Figure 14. MAX1402 to 8051 Interface

```

/* Low-level function to write 8 bits
** The example shown here is for a bit-banging system with (CPOL=1, CPHA=1)
*/
void WriteByte (BYTE x)
{
    drive SCK pin high
    count = 0;
    while (count <= 7)
    {
        if (bit 7 of x is 1)
            drive DIN pin high
        else
            drive DIN pin low
        drive SCK pin low
        x = x * 2;
        drive SCK pin high
        count = count + 1;
    }
}

/* Low-level function to read 8 bits
** The example shown here is for a bit-banging system with (CPOL=1, CPHA=1)
*/
BYTE ReadByte (void)
{
    x = 0;
    drive SCK pin high
    count = 0;
    while (count <= 7)
    {
        x = x * 2;
        drive SCK pin low
        if (DOUT pin is high)
            x = x + 1;
        drive SCK pin high
        count = count + 1;
    }
}
return x;

```

Figure 15. Bit-Banging SPI Replacement

+5V, 18-Bit, Low-Power, Multichannel, Oversampling (Sigma-Delta) ADC

4–20mA Loop-Powered Transmitters

Low power, single-supply operation, and easy interfacing with optocouplers make the MAX1402 ideal for loop-powered 4–20mA transmitters. Loop-powered transmitters draw their power from the 4–20mA loop, limiting the transmitter circuitry to a current budget of 4mA. Tolerances in the loop further limit this current budget to 3.5mA. Since the MAX1402 consumes only 250µA, a total of 3.25mA remains to power the remaining transmitter circuitry. Figure 18 shows a block diagram for a loop-powered 4–20mA transmitter.

Power Supplies

No specific power sequence is required for the MAX1402; either the V+ or the VDD supply can come up first. While the latchup performance of the MAX1402 is good, it is important that power be applied to the MAX1402 before the analog input signals (AIN_) or the CLKIN inputs, to avoid latchup. If this is not possible, then the current flow into any of these pins should be limited to 50mA. If separate supplies are used for the MAX1402 and the system digital circuitry, then the MAX1402 should be powered up first.

3-Wire and 4-Wire RTD Configurations

Tightly matched 200µA current sources compensate for errors in 3-wire and 4-wire RTD configurations. In the 3-wire configuration (Figure 19), the lead resistances result in errors if only one current source is used. The 200µA will flow through RL1 developing a voltage error between AIN1 and AIN2. An additional current source compensates for this error by developing an equivalent voltage across RL2 ensuring the differential voltage at AIN1 and AIN2 is not affected by lead resistance. This assumes both leads are of the same material and of equal length (RL1 = RL2) and OUT1 and OUT2 have matching tempcos (5ppm/°C). Both current sources will flow through RL3 developing a common-mode voltage that will not affect the differential voltage at AIN1 and AIN2. Using one of the current sources to supply the reference voltage ensures a more accurate ratiometric result.

Unlike the 3-wire configuration, the 4-wire configuration (Figure 20) has no error associated with lead resistances as no current flows in the measurement leads connected to AIN1 and AIN2. Current source OUT1 provides the excitation current for the RTD and current source OUT2 provides current to generate the reference voltage. This reference voltage developed across RREF ensures that the analog input voltage span remains ratiometric to the reference voltage. RTD tempco errors in the analog input voltage are due to the tem-

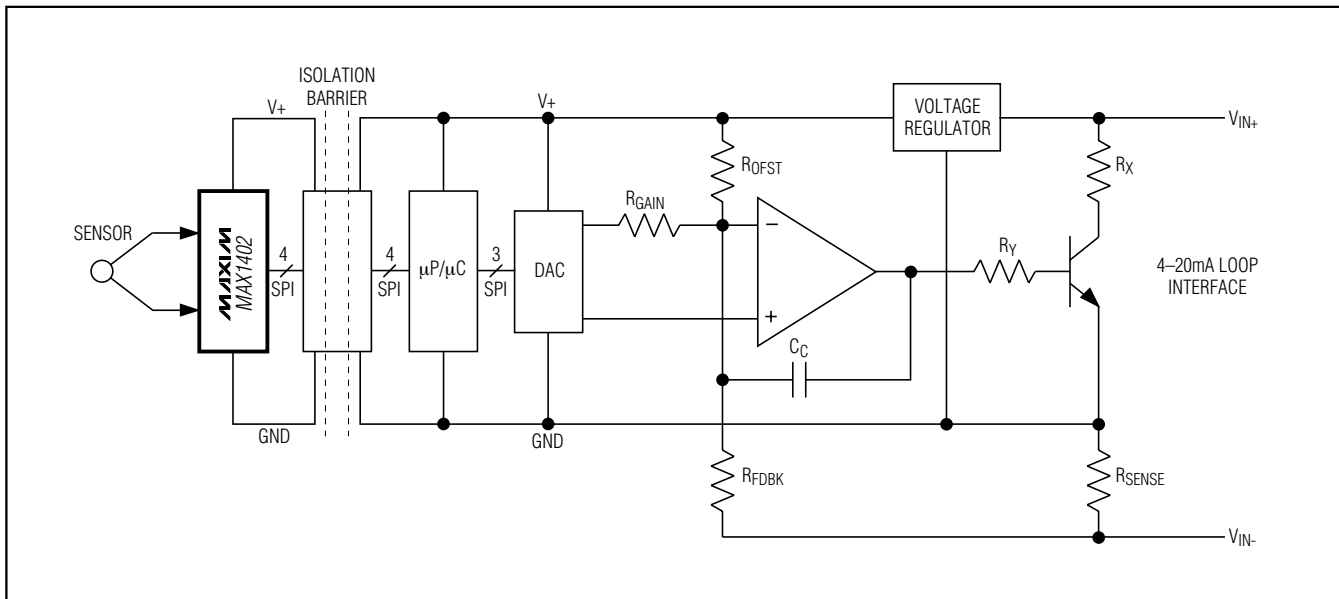

Figure 18. 4–20mA Transmitter

+5V, 18-Bit, Low-Power, Multichannel, Oversampling (Sigma-Delta) ADC

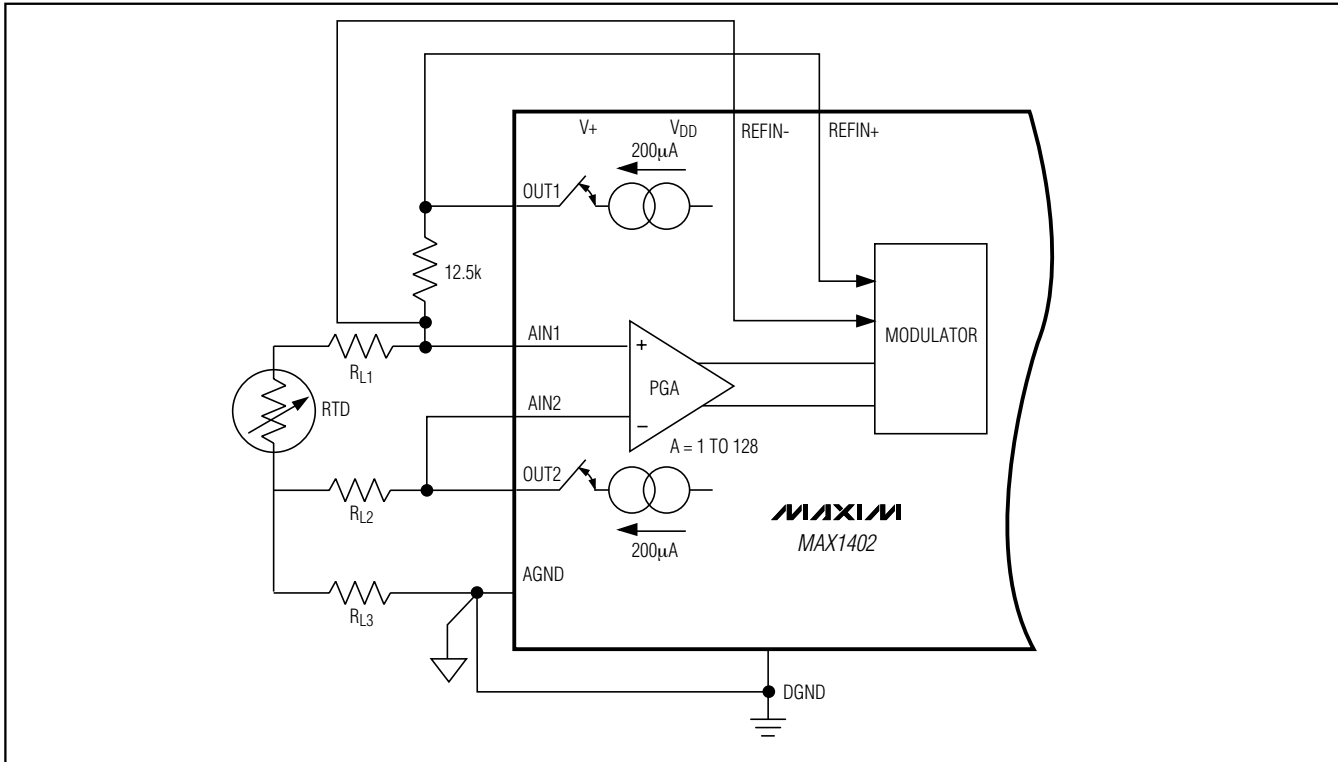

Figure 19. 3-Wire RTD Application

perature drift of the RTD current source and compensated for by the variation in the reference voltage. A common resistance value for the RTD is 100Ω generating a 20mV signal directly handled at the analog input of the MAX1402. The voltage at OUT1 and OUT2 can go to within 1.0V of the V+ supply.

Grounding and Layout

For best performance, use printed circuit boards with separate analog and digital ground planes. Wire-wrap boards are not recommended.

Design the printed circuit board so that the analog and digital sections are separated and confined to different areas of the board. Join the digital and analog ground planes at only one point. If the MAX1402 is the only device requiring an AGND to DGND connection, then the ground planes should be connected at the AGND and DGND pins of the MAX1402. In systems where multiple devices require AGND to DGND connections, the

connection should still be made at only one point. Make the star ground as close to the MAX1402 as possible.

Avoid running digital lines under the device, because these may couple noise onto the die. Run the analog ground plane under the MAX1402 to minimize coupling of digital noise. Make the power-supply lines to the MAX1402 as wide as possible to provide low-impedance paths and reduce the effects of glitches on the power-supply line.

Shield fast switching signals, such as clocks, with digital ground to avoid radiating noise to other sections of the board. Avoid running clock signals near the analog inputs. Avoid crossover of digital and analog signals. Traces on opposite sides of the board should run at right angles to each other. This will reduce the effects of feedthrough on the board. A microstrip technique is best, but is not always possible with double-sided boards. In this technique, the component side of the

+5V, 18-Bit, Low-Power, Multichannel, Oversampling (Sigma-Delta) ADC

MAX1402

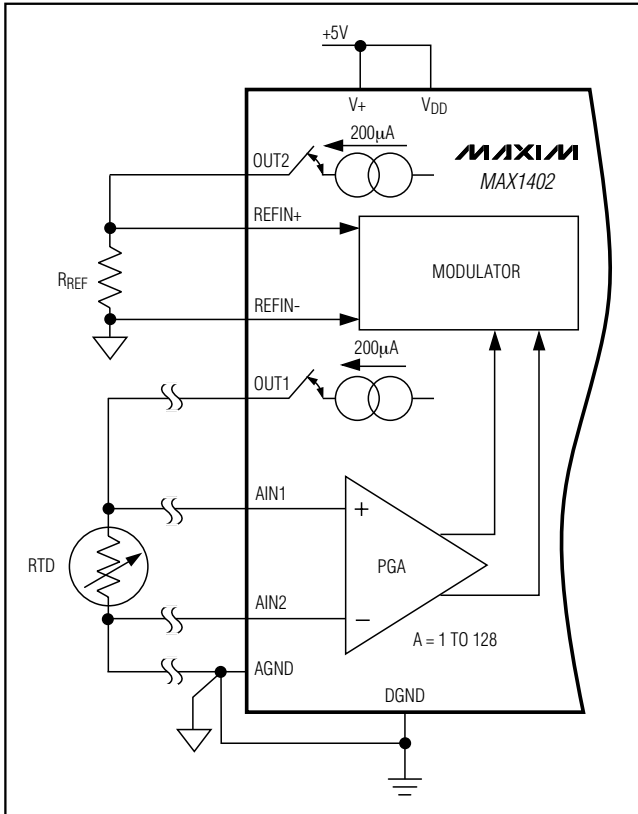

Figure 20. 4-Wire RTD Application

board is dedicated to ground planes while signals are placed on the solder side.

Good decoupling is important when using high-resolution ADCs. Decouple all analog supplies with 10µF tantalum capacitors in parallel with 0.1µF HF ceramic capacitors to AGND. Place these components as close to the device as possible to achieve the best decoupling.

See the MAX1402 evaluation kit manual for the recommended layout. The evaluation board package includes a fully assembled and tested evaluation board.

Optical Isolation

For applications that require an optically isolated interface, refer to Figure 21. With 6N136-type optocouplers, maximum clock speed is 4MHz. Maximum clock speed is limited by the degree of mismatch between the individual optocouplers. Faster optocouplers allow faster signaling at a higher cost.

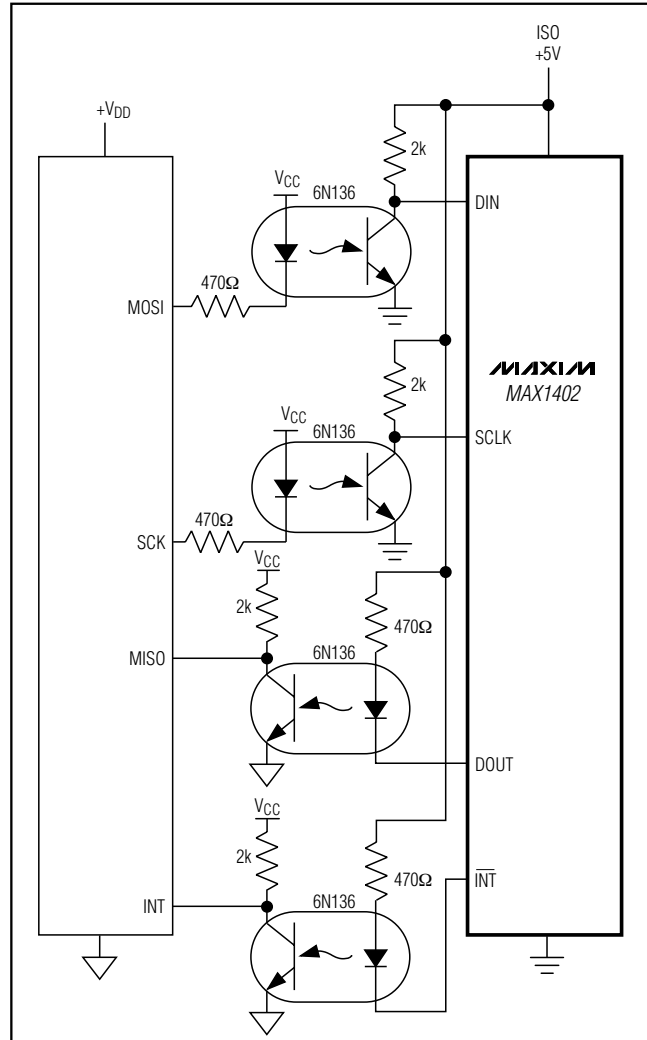

Figure 21. Optically Isolated Interface

Chip Information

TRANSISTOR COUNT: 34,648
SUBSTRATE CONNECTED TO AGND

Revision History

Pages changed at Rev2: 1, 37, 38

+5V, 18-Bit, Low-Power, Multichannel, Oversampling (Sigma-Delta) ADC

Package Information

(The package drawing(s) in this data sheet may not reflect the most current specifications. For the latest package outline information go to www.maxim-ic.com/packages.)

DIM	INCHES		MILLIMETERS	
	MIN	MAX	MIN	MAX
A	0.068	0.078	1.73	1.99
A1	0.002	0.008	0.05	0.21
B	0.010	0.015	0.25	0.38
C	0.004	0.008	0.09	0.20
D	SEE VARIATIONS			
E	0.205	0.212	5.20	5.38
e	0.0256 BSC		0.65 BSC	
H	0.301	0.311	7.65	7.90
L	0.025	0.037	0.63	0.95
α	0 $^\infty$	8 $^\infty$	0 $^\infty$	8 $^\infty$

D	INCHES		MILLIMETERS		N
	MIN	MAX	MIN	MAX	
D	0.239	0.249	6.07	6.33	14L
D	0.239	0.249	6.07	6.33	16L
D	0.278	0.289	7.07	7.33	20L
D	0.317	0.328	8.07	8.33	24L
D	0.397	0.407	10.07	10.33	28L

NOTES:

1. D&E DO NOT INCLUDE MOLD FLASH.
2. MOLD FLASH OR PROTRUSIONS NOT TO EXCEED .15 MM (.006").
3. CONTROLLING DIMENSION: MILLIMETERS.
4. MEETS JEDEC MO150.
5. LEADS TO BE COPLANAR WITHIN 0.10 MM.

<small>PROPRIETARY INFORMATION</small>		
TITLE: PACKAGE OUTLINE, SSOP, 5.3 MM		
<small>APPROVAL</small>	<small>DOCUMENT CONTROL NO.</small> 21-0056	<small>REV.</small> C 1/1

SSOP-EPS

Maxim cannot assume responsibility for use of any circuitry other than circuitry entirely embodied in a Maxim product. No circuit patent licenses are implied. Maxim reserves the right to change the circuitry and specifications without notice at any time.



Компания «ЭлектроПласт» предлагает заключение долгосрочных отношений при поставках импортных электронных компонентов на взаимовыгодных условиях!

Наши преимущества:

- Оперативные поставки широкого спектра электронных компонентов отечественного и импортного производства напрямую от производителей и с крупнейших мировых складов;
- Поставка более 17-ти миллионов наименований электронных компонентов;
- Поставка сложных, дефицитных, либо снятых с производства позиций;
- Оперативные сроки поставки под заказ (от 5 рабочих дней);
- Экспресс доставка в любую точку России;
- Техническая поддержка проекта, помощь в подборе аналогов, поставка прототипов;
- Система менеджмента качества сертифицирована по Международному стандарту ISO 9001;
- Лицензия ФСБ на осуществление работ с использованием сведений, составляющих государственную тайну;
- Поставка специализированных компонентов (Xilinx, Altera, Analog Devices, Intersil, Interpoint, Microsemi, Aeroflex, Peregrine, Syfer, Eurofarad, Texas Instrument, Miteq, Cobham, E2V, MA-COM, Hittite, Mini-Circuits, General Dynamics и др.);

Помимо этого, одним из направлений компании «ЭлектроПласт» является направление «Источники питания». Мы предлагаем Вам помощь Конструкторского отдела:

- Подбор оптимального решения, техническое обоснование при выборе компонента;
- Подбор аналогов;
- Консультации по применению компонента;
- Поставка образцов и прототипов;
- Техническая поддержка проекта;
- Защита от снятия компонента с производства.



Как с нами связаться

Телефон: 8 (812) 309 58 32 (многоканальный)

Факс: 8 (812) 320-02-42

Электронная почта: org@eplast1.ru

Адрес: 198099, г. Санкт-Петербург, ул. Калинина, дом 2, корпус 4, литера А.