

Features

- Cascadable
- Low Insertion Loss
- Low DC Power Consumption
- Low Distortion Operation (Quiet Mode)
- Useful as a Building Block for
 - Digital Attenuators
 - Digital Delay Lines
 - Digital Phase Shifters
 - Digital Switched Filter Elements

Description

M/A-COM's MASW2040 is a GaAs MMIC DPDT switch die. The MASW2040 is ideally suited for use where low power consumption is required.

Typical applications include transmit/receive switching, switch matrices, and switched filter banks in systems such as radio and cellular equipment, PCM, GPS, fiber optic modules, and other battery powered radio equipment.

Ordering Information

Part Number	Package
MASW2040	DIE

Absolute Maximum Rating ^{1,2}

Parameter	Absolute Maximum
Control Value (A or B)	-8.5 Vdc
Max Input RF Power	+34 dBm
Storage Temperature	-65°C to +175°C
Max Operating Temperature	+175°C

1. Exceeding any one or combination of these limits may cause permanent damage to this device.
2. M/A-COM does not recommend sustained operation near these survivability limits.

Pad Layout

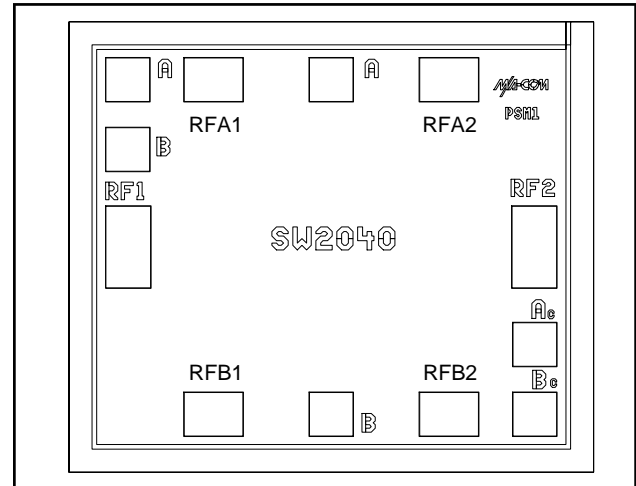

Die Size—Inches (mm)

0.043 x 0.037 x 0.010 (1.10 x 0.94 x 0.25)

Bond Pad Dimensions

Bond Pad	Dimensions - Inches (mm)
RF1, RF2	0.004 x 0.007 (0.102 x 0.182)
RFA1, RFB1	0.005 x 0.004 (0.133 x 0.100)
RFA2, RFB2	0.005 x 0.004 (0.133 x 0.100)
A, B, Ac, Bc	0.004 x 0.004 (0.100 x 0.100)

Schematic

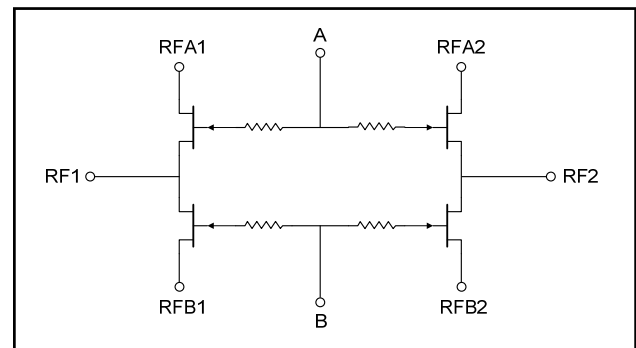

Electrical Specifications: 0 / -5 Vdc, -55°C to +85°C

Parameter	Test Conditions	Units	Min.	Typ.	Max.
Insertion Loss	DC - 0.5 GHz	dB	—	—	0.4
	DC - 1.0 GHz	dB	—	—	0.4
	DC - 2.0 GHz	dB	—	—	0.6
Isolation	DC - 0.5 GHz	dB	25	—	—
	DC - 1.0 GHz	dB	20	—	—
	DC - 2.0 GHz	dB	15	—	—
VSWR	DC - 0.5 GHz	Ratio	—	—	1.1:1
	DC - 1.0 GHz	Ratio	—	—	1.2:1
	DC - 2.0 GHz	Ratio	—	—	1.2:1
Input P-1dB	0.05 GHz (0 / -5 V, 0 / -8V)	dBm	—	+24, +25	—
	0.5 - 2.0 GHz (0 / -5 V, 0 / -8V)	dBm	—	+30, +33	—
IP2	Two Tone Input Power up to +5 dBm 0.05 GHz	dBm	—	+62	—
	0.5 - 2.0 GHz	dBm	—	+68	—
IP3	Two Tone Input Power up to +5 dBm 0.05 GHz	dBm	—	+39	—
	0.5 - 2.0 GHz	dBm	—	+46	—
Control Current	V _{IN} Low (0 to -0.2 V)	μA	—	—	9
	V _{IN} High (-5 V @ 25 μA Typ to -8 V)	μA	—	—	75
T-rise, T-fall	10% to 90% RF and 90% to 10% RF	ns	—	3	—
T _{ON} , T _{OFF}	50% control to 90% RF, and 50% control to 90% RF	ns	—	6	—
Transients	In Band	mV	—	20	—

Truth Table ³

Control		Condition of Switch			
A	B	RF1-RFA1	RF1-RFB1	RF2-RFA2	RF2-RFB2
1	0	Off	On	Off	On
0	1	On	Off	On	Off

3. 0 = 0 to -0.2 V, 1 = -5 V.

Handling Procedures

Please observe the following precautions to avoid damage:

Static Sensitivity

Gallium Arsenide Integrated Circuits are sensitive to electrostatic discharge (ESD) and can be damaged by static electricity. Proper ESD control techniques should be used when handling these devices.

Typical Performance @ 25°C

Insertion Loss vs. Frequency

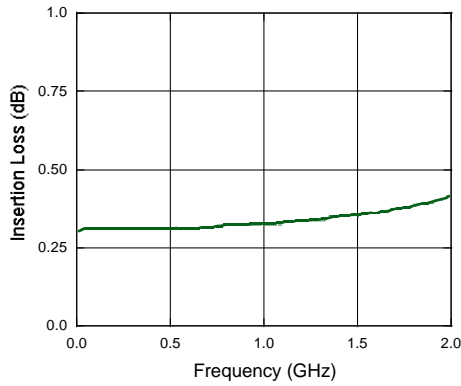

VSWR vs. Frequency

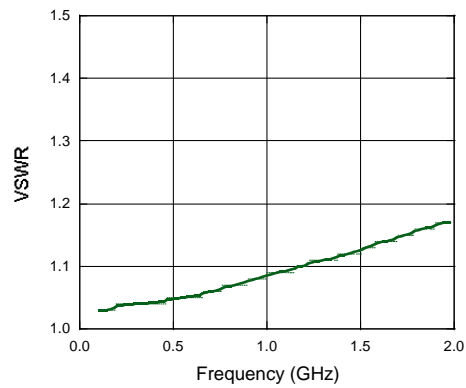

Isolation vs. Frequency

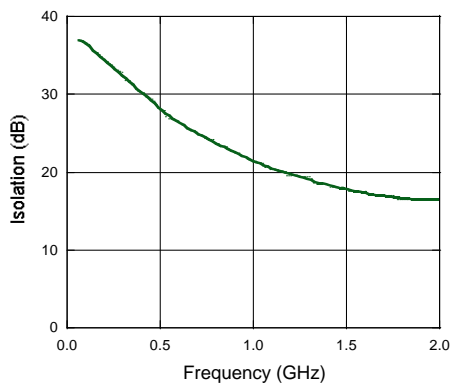

Handling Precautions

Permanent damage to the MASW2040 may occur if the following precautions are not adhered to:

- A. Cleanliness - The MASW2040 should be handled in a clean environment. DO NOT attempt to clean unit after the MASW2040 is installed.
- B. Static Sensitivity - All chip handling equipment and personnel should be DC grounded.
- C. Transient - Avoid instrument and power supply transients while bias is applied to the MASW2040. Use shielded signal and bias cables to minimize inductive pick-up.
- D. Bias - Apply Voltage to either control port A or B only when the other is grounded. Neither port should be allowed to "float."
- E. General Handling - It is recommended that the MASW2040 chip be handled along the long side of the die with a sharp pair of bent tweezers. DO NOT touch the surface of the chip with fingers or tweezers.

Mounting

The MASW2040 is back-metallized with Pd/Ni/Au (100/1,000/10,000Å) metallization. It can be die-mounted with AuSn eutectic performs or with thermally conductive epoxy. The package surface should be clean and flat before attachment.

Eutectic Die Attach:

- A. A 80/20 gold/tin preform is recommended with a work surface temperature of approximately 255°C and a tool temperature of 265°C. When not 90/10 nitrogen/hydrogen gas is applied, tool tip temperature should be approximately 290°C.
- B. DO NOT expose the MASW2040 to a temperature greater than 320°C for more than 20 seconds. No more than 3 seconds for scrubbing should be required for attachment.

Epoxy Die Attach:

- A. Apply a minimum amount of epoxy and place the MASW2040 into position. A thin epoxy fillet should be visible around the perimeter of the chip.
- B. Cure epoxy per manufacturer's recommended schedule.
- C. Electrically conductive epoxy may be used by is not required.

Wire Bonding

- A. Ball or wedge with 1.0 mil diameter pure gold wire. Thermosonic wirebonding with a nominal stage temperature of 150°C and a ball bonding force of 40 to 50 grams or wedge bonding force of 18 to 22 grams is recommended. Ultrasonic energy and time should be adjusted to the minimum levels achieve reliable wirebonds.
- B. Wirebonds should be started on the chip and terminated on the package. GND bonds should be as short as possible; at least three and no more than four bond wires from ground pads to package are recommended.



Компания «ЭлектроПласт» предлагает заключение долгосрочных отношений при поставках импортных электронных компонентов на взаимовыгодных условиях!

Наши преимущества:

- Оперативные поставки широкого спектра электронных компонентов отечественного и импортного производства напрямую от производителей и с крупнейших мировых складов;
- Поставка более 17-ти миллионов наименований электронных компонентов;
- Поставка сложных, дефицитных, либо снятых с производства позиций;
- Оперативные сроки поставки под заказ (от 5 рабочих дней);
- Экспресс доставка в любую точку России;
- Техническая поддержка проекта, помощь в подборе аналогов, поставка прототипов;
- Система менеджмента качества сертифицирована по Международному стандарту ISO 9001;
- Лицензия ФСБ на осуществление работ с использованием сведений, составляющих государственную тайну;
- Поставка специализированных компонентов (Xilinx, Altera, Analog Devices, Intersil, Interpoint, Microsemi, Aeroflex, Peregrine, Syfer, Eurofarad, Texas Instrument, Miteq, Cobham, E2V, MA-COM, Hittite, Mini-Circuits, General Dynamics и др.);

Помимо этого, одним из направлений компании «ЭлектроПласт» является направление «Источники питания». Мы предлагаем Вам помощь Конструкторского отдела:

- Подбор оптимального решения, техническое обоснование при выборе компонента;
- Подбор аналогов;
- Консультации по применению компонента;
- Поставка образцов и прототипов;
- Техническая поддержка проекта;
- Защита от снятия компонента с производства.



Как с нами связаться

Телефон: 8 (812) 309 58 32 (многоканальный)

Факс: 8 (812) 320-02-42

Электронная почта: org@eplast1.ru

Адрес: 198099, г. Санкт-Петербург, ул. Калинина, дом 2, корпус 4, литера А.