

RabbitNet Peripheral Cards

RabbitNet LAN Cards

User's Manual

019-0146 • 070629-D

RabbitNet Peripheral Cards User's Manual

Part Number 019-0146 • 07029-D • Printed in U.S.A.

©2005–2007 Rabbit Semiconductor Inc. • All rights reserved.

No part of the contents of this manual may be reproduced or transmitted in any form or by any means without the express written permission of Rabbit Semiconductor.

Permission is granted to make one or more copies as long as the copyright page contained therein is included. These copies of the manuals may not be let or sold for any reason without the express written permission of Rabbit Semiconductor.

Rabbit Semiconductor reserves the right to make changes and improvements to its products without providing notice.

Trademarks

Rabbit and Dynamic C are registered trademarks of Rabbit Semiconductor Inc.

RabbitNet is a trademark of Rabbit Semiconductor Inc.

The latest revision of this manual is available on the Rabbit Semiconductor Web site, www.rabbit.com, for free, unregistered download.

Rabbit Semiconductor Inc.

www.rabbit.com

TABLE OF CONTENTS

Chapter 1. The RabbitNet Protocol	1
1.1 General RabbitNet Description	1
1.1.1 RabbitNet Connections	1
1.1.2 RabbitNet Peripheral Cards	2
1.1.3 Connectivity Tools	3
1.1.4 DIN Rail Mounting	4
1.2 Physical Implementation	5
1.2.1 Control and Routing	5
1.3 Dynamic C	6
1.3.1 Dynamic C Libraries	6
1.3.1.1 Accessing and Downloading Dynamic C Libraries	7
1.3.2 Sample Programs	8
1.3.3 General RabbitNet Operation	8
1.3.4 General RabbitNet Function Calls	9
1.3.5 Status Byte	15
Chapter 2. Digital I/O Card	17
2.1 Features	18
2.1.1 Software	18
2.2 Connections	19
2.2.1 Power Supply	20
2.3 Pinout	22
2.3.1 Headers	22
2.3.2 Indicator LED	22
2.4 Digital I/O	23
2.4.1 Digital Inputs	23
2.4.2 Digital Outputs	24
2.5 Analog Inputs	26
2.5.1 Single-Ended Inputs	27
2.5.2 Differential Inputs	27
2.5.3 Calibrating the Analog Inputs	27
2.5.3.1 Calibration Constants	28
2.5.3.2 Calibration Recommendations	28
2.5.3.3 Factory Calibration	29
2.6 Software	30
2.6.1 Dynamic C Libraries	30
2.6.2 Sample Programs	30
2.6.2.1 Digital I/O	30
2.6.2.2 Analog Inputs	32
2.6.3 Digital I/O Card Function Calls	34
2.6.3.1 Digital Input Function Calls	34
2.6.3.2 Digital Output Function Calls	35
2.6.3.3 Analog Input Function Calls	37
2.6.4 Status Byte	44
2.7 Specifications	45
2.7.1 Electrical and Mechanical Specifications	45
2.7.1.1 Physical Mounting	47
2.7.2 Jumper Configurations	48

Chapter 3. A/D Converter Card	51
3.1 Features	52
3.1.1 Software.....	52
3.2 Connections.....	53
3.2.1 Power Supply.....	54
3.3 Pinout	55
3.3.1 Headers	55
3.3.2 Indicator LED.....	55
3.4 Analog Inputs	56
3.4.1 Analog Current Measurements.....	58
3.4.2 Calibrating the A/D Converter Chip.....	59
3.4.2.1 Modes	59
3.4.2.2 Calibration Constants	59
3.4.2.3 Calibration Recommendations.....	60
3.4.2.4 Factory Calibration	61
3.5 Software	62
3.5.1 Dynamic C Libraries	62
3.5.2 Sample Programs.....	62
3.5.3 A/D Converter Card Function Calls	65
3.5.4 Status Byte.....	77
3.6 Specifications	78
3.6.1 Electrical and Mechanical Specifications.....	78
3.6.2 Physical Mounting.....	80
3.7 Jumper Configurations	81
Chapter 4. D/A Converter Card	83
4.1 Features	84
4.1.1 Software.....	84
4.2 Connections.....	85
4.2.1 Power Supply.....	86
4.3 Pinout	87
4.3.1 Headers	87
4.3.2 Indicator LED.....	87
4.4 D/A Converter Outputs	88
4.4.1 Calibration	89
4.5 Software	90
4.5.1 Dynamic C Libraries	90
4.5.2 Sample Programs.....	90
4.5.3 D/A Converter Card Function Calls	92
4.5.4 Status Byte.....	99
4.6 Specifications	100
4.6.1 Electrical and Mechanical Specifications.....	100
4.6.2 Physical Mounting.....	102
Chapter 5. Relay Card	103
5.1 Features	104
5.1.1 Software.....	104
5.2 Connections.....	105
5.2.1 Power Supply.....	106
5.3 Pinout	108
5.3.1 Headers	108
5.3.2 Indicator LEDs	108
5.4 Relay Outputs.....	109
5.5 Software	110
5.5.1 Dynamic C Libraries	110
5.5.2 Sample Programs.....	110
5.5.3 Relay Card Function Calls.....	112
5.5.4 Status Byte.....	115

5.6 Specifications	116
5.6.1 Electrical and Mechanical Specifications	116
5.6.2 Physical Mounting	118
Chapter 6. Keypad/Display Interface	119
6.1 Features	120
6.1.1 Software	120
6.2 Connections	121
6.2.1 Power Supply	122
6.3 Key RabbitNet Keypad/Display Interface Components	123
6.3.1 Headers and Jacks	123
6.3.1.1 Keypads.....	123
6.3.1.2 Liquid Crystal Displays.....	124
6.3.2 LEDs	124
6.3.3 Buzzer	124
6.4 Liquid Crystal Display Backlights.....	125
6.5 Display Contrast	127
6.6 Software	128
6.6.1 Dynamic C Libraries	128
6.6.2 Sample Programs	128
6.6.3 RabbitNet Keypad/Display interface Function Calls	130
6.6.3.1 Buzzer.....	130
6.6.3.2 LEDs.....	131
6.6.3.3 Keypad	132
6.6.3.4 Display	135
6.6.4 Status Byte	141
6.7 Specifications.....	142
6.8 Electrical and Mechanical Specifications	142
6.8.1 Physical Mounting	144
Appendix A. Keypad/Display Interface Expansion Kit	145
A.1 Keypads.....	146
A.1.1 Keypad Templates.....	147
A.2 LCD Displays.....	150
A.2.1 2 × 20 Character LCD.....	151
A.2.2 4 × 20 Character LCD	151
A.3 ZMENU.C.....	152
A.4 Configuring Key Code Indexes and Physical Keypad Arrangement.....	156
A.4.1 Basics of Assigning Key Code Indexes	156
A.4.2 Expansion Kit Keypads.....	158
A.4.2.1 3 × 4 Keypad	158
A.4.2.2 2 × 6 Keypad	159
A.4.2.3 4 × 10 Keypad	160
A.5 2 × 6 Keypad Datasheet	161
A.6 3 × 4 Keypad Datasheet	162
A.7 4 × 10 Keypad Datasheet	163
A.8 2 × 20 Character LCD Datasheet	164
A.9 4 × 20 Character LCD Datasheet	188
Index	195
Schematics	199

1. THE RABBITNET PROTOCOL

1.1 General RabbitNet Description

RabbitNet is a high-speed synchronous protocol developed by Rabbit Semiconductor to connect peripheral cards to a master and to allow them to communicate with each other.

1.1.1 RabbitNet Connections

All RabbitNet connections are made point to point. A RabbitNet master port can only be connected directly to a peripheral card, and the number of peripheral cards is limited by the number of available RabbitNet ports on the master.

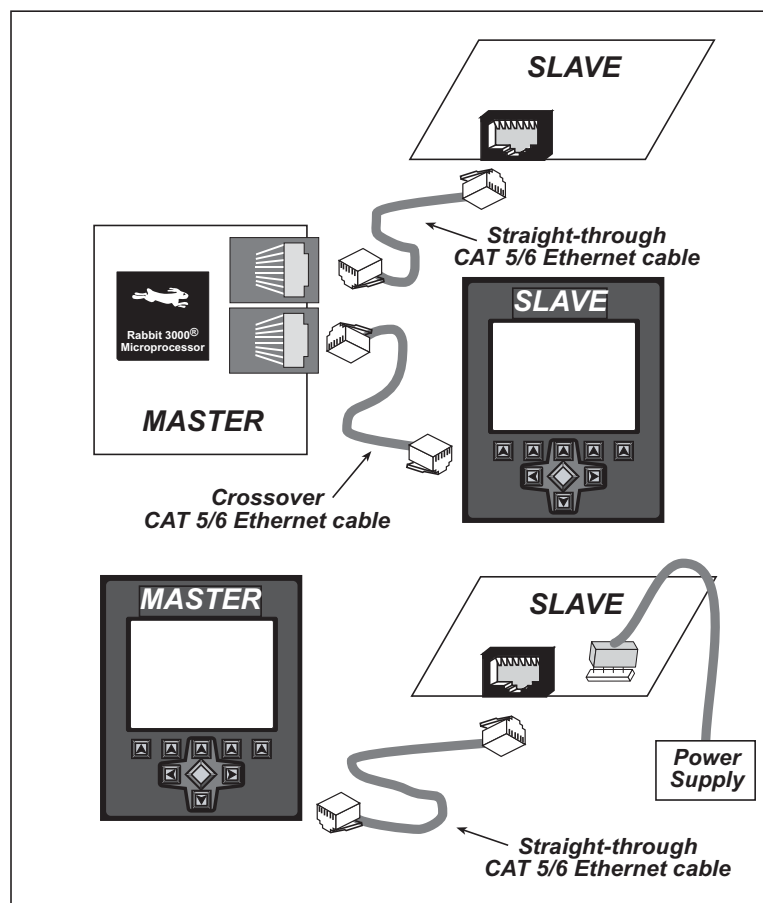

Figure 1. Connecting Peripheral Cards to a Master

A typical RabbitNet™ system consists of a master single-board computer and one or two peripheral cards. A high-performance Rabbit 3000® or Rabbit 2000® microprocessor on the master provides fast data processing, and a BL2500 or a BL2600 master also provides the DCIN and +5 V power for the peripheral cards. Use a straight-through CAT 5/6 Ethernet cable to connect the master to slave peripheral cards, unless you are using a device such as the OP7200 that could be used either as a master or a slave. In this case you would use a crossover CAT 5/6 Ethernet cable to connect an OP7200 that is being used as a slave.

NOTE: Even though CAT 5/6 Ethernet cables are used for the RabbitNet connections, *never* connect a RabbitNet port to an Ethernet network. Doing so could destroy the RabbitNet SPI driver.

Distances between a master unit and peripheral cards can be up to 10 m or 33 ft.

Table 1 lists Rabbit Semiconductor’s single-board computers and other devices that can be used as the master in a RabbitNet system.

Table 1. RabbitNet Master Capabilities

RabbitNet Masters	Master Supplies Power to Peripheral Cards	Number of RabbitNet Ports
BL2500	Yes	2
BL2600	Yes	2
OP7200	No	1
RCM3300/RCM3360 Prototyping Board	No	1
PowerCore FLEX Prototyping Board	No	1

1.1.2 RabbitNet Peripheral Cards

- Digital I/O Card

24 inputs, 16 push/pull outputs, 4 channels of 10-bit A/D conversion with ranges of 0 to 10 V, 0 to 1 V, and -0.25 to +0.25 V. The following connectors are used:

- Signal = 0.1" friction-lock connectors
- Power = 0.156" friction-lock connectors
- RabbitNet = RJ-45 connector

- A/D Converter Card

8 channels of programmable-gain 12-bit A/D conversion, configurable as current measurement and differential-input pairs. 2.5 V reference voltage is available on the connector. The following connectors are used:

- Signal = 0.1" friction-lock connectors
- Power = 0.156" friction-lock connectors
- RabbitNet = RJ-45 connector

- D/A Converter Card

8 channels of 0–10 V 12-bit D/A conversion. The following connectors are used:

Signal = 0.1" friction-lock connectors

Power = 0.156" friction-lock connectors

RabbitNet = RJ-45 connector

- Display/Keypad interface

Allows you to connect your own keypad with up to 64 keys and one character liquid crystal display from 1×8 to 4×20 characters with or without backlight using standard 1×16 or 2×8 connectors. The following connectors are used:

Signal = 0.1" headers or sockets

Power = 0.156" friction-lock connectors

RabbitNet = RJ-45 connector

- Relay Card

6 relays rated at 250 V AC, 1200 V·A or 100 V DC up to 240 W. The following connectors are used:

Relay contacts = screw-terminal connectors

Power = 0.156" friction-lock connectors

RabbitNet = RJ-45 connector

The OP7200 operator interface may serve as a RabbitNet peripheral card “display” in a RabbitNet system.

Visit our [Web site](#) for up-to-date information about additional cards and features as they become available. The Web site also has the latest revision of this user’s manual.

1.1.3 Connectivity Tools

Rabbit Semiconductor also has available additional tools and parts to allow you to make your own wiring assemblies to interface with the friction-lock connectors on the RabbitNet peripheral cards.

- Connectivity Kit (Part No. 101-0581)—Six 1×10 friction-lock connectors (0.1" pitch) with sixty 0.1" crimp terminals; and two 1×4 friction-lock connectors (0.156" pitch) and two 1×2 friction-lock connectors (0.156" pitch) with fifteen 0.156" crimp terminals. Each kit contains sufficient parts to interface with one or more RabbitNet peripheral cards.
- Crimp tool (Part No. 998-0013) to secure wire in crimp terminals.

Contact your authorized Rabbit Semiconductor distributor or your Rabbit Semiconductor Sales Representative for more information.

1.1.4 DIN Rail Mounting

RabbitNet peripheral cards and the BL2500 master may be mounted in 100 mm DIN rail trays as shown in Figure 2.

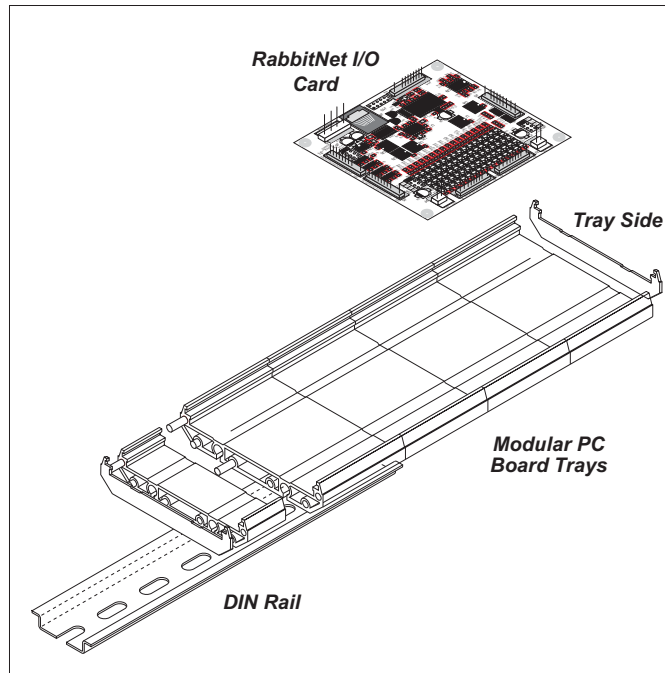

Figure 2. Mounting RabbitNet Peripheral Card in DIN Rail Trays

DIN rail trays are typically mounted on DIN rails with “feet.” Table 2 lists Phoenix Contact part numbers for the DIN rail trays, rails, and feet. The tray side elements are used to keep the RabbitNet peripheral card in place once it is inserted in a DIN rail tray, and the feet are used to mount the plastic tray on a DIN rail.

Table 2. Phoenix Contact DIN Rail Mounting Components

DIN Rail Mounting Component	Phoenix Contact Part Description	Phoenix Contact Part Number
Trays	UM 100-PROFIL cm*	19 59 87 4
Tray Side Elements	UM 108-SE	29 59 47 6
Foot Elements	UM 108-FE	29 59 46 3

* Length of DIN rail tray in cm

NOTE: Other major suppliers besides Phoenix Contact also offer DIN rail mounting hardware. Note that the width of the plastic tray should be 100 mm (3.95") since that is the width of a RabbitNet peripheral card. 108 mm plastic trays may be used with spacers.

1.2 Physical Implementation

There are four signaling functions associated with a RabbitNet connection. From the master's point of view, the transmit function carries information and commands to the peripheral card. The receive function is used to read back information sent to the master by the peripheral card. A clock is used to synchronize data going between the two devices at high speed. The master is the source of this clock. A slave select (SS) function originates at the master, and when detected by a peripheral card causes it to become selected and respond to commands received from the master.

The signals themselves are differential RS-422, which are series-terminated at the source. With this type of termination, the maximum frequency is limited by the round-trip delay time of the cable. Although a peripheral card could theoretically be up to 45 m (150 ft) from the master for a data rate of 1 MHz, Rabbit Semiconductor recommends a practical limit of 10 m (33 ft).

Connections between peripheral cards and masters are done using standard 8-conductor CAT 5/6 Ethernet cables. Masters and peripheral cards are equipped with RJ-45 8-pin female connectors. The cables may be swapped end for end without affecting functionality.

1.2.1 Control and Routing

Control starts at the master when the master asserts the slave select signal (SS). Then it simultaneously sends a serial command and clock. The first byte of a command contains the address of the peripheral card if more than one peripheral card is connected.

A peripheral card assumes it is selected as soon as it receives the select signal. For direct master-to-peripheral-card connections, this is as soon as the master asserts the select signal. The connection is established once the select signal reaches the addressed slave. At this point communication between the master and the selected peripheral card is established, and data can flow in both directions simultaneously. The connection is maintained so long as the master asserts the select signal.

1.3 Dynamic C

Dynamic C is an integrated development system for writing embedded software. It runs on an IBM-compatible PC and is designed for use with Rabbit Semiconductor single-board computers and other devices based on the Rabbit microprocessor.

1.3.1 Dynamic C Libraries

In addition to the library associated with the master single-board computer such as the BL2500 or OP7200, several other libraries are needed to provide function calls for RabbitNet peripheral cards.

- **RN_CFG_BL25.LIB**—used to configure the BL2500 for use with RabbitNet peripheral cards. Function calls for this library are discussed in the *Coyote (BL2500) User's Manual*.
- **RN_CFG_BL26.LIB**—used to configure the BL2600 for use with RabbitNet peripheral cards. Function calls for this library are discussed in the *Wolf (BL2600) User's Manual*.
- **RN_CFG_OP72.LIB**—used to configure the OP7200 for use with RabbitNet peripheral cards. Function calls for this library are discussed in the *eDisplay (OP7200) User's Manual*.
- **RN_CFG_PowerCoreFLEX.LIB**—used to configure the PowerCore FLEX modules for use with RabbitNet peripheral boards on the PowerCore FLEX Prototyping Board. Function calls for this library are discussed in the *PowerCore FLEX User's Manual*.
- **RN_CFG_RCM33.LIB**—used to configure the RCM3300, RCM3310, RCM3360, and RCM3370 for use with RabbitNet peripheral boards on the RCM3300 Prototyping Board. Function calls for this library are discussed in the *RCM3300/RCM3310 User's Manual* and in the *RCM3360/RCM3370 User's Manual*.
- **RNET.LIB**—provides functions unique to the RabbitNet protocol. Function calls for this library are presented below.
- **RNET_DRIVER.LIB**—provides background functions unique to the RabbitNet data transmission protocol.

Function calls specific to individual RabbitNet peripheral cards are described in the chapters specific to the individual RabbitNet peripheral card. Other functions applicable to all devices based on Rabbit microprocessors are described in the *Dynamic C Function Reference User's Manual*. More complete information on Dynamic C is provided in the *Dynamic C User's Manual*.

1.3.1.1 Accessing and Downloading Dynamic C Libraries

The libraries needed to run the RabbitNet peripheral cards are available on the CD included with the Development Kit for the master single-board computer, or they may be downloaded from <http://www.rabbit.com/support/downloads/> on Rabbit Semiconductor's Web site.

When downloading the libraries from the Web site, click on the product-specific links until you reach the links for the RabbitNet peripheral cards download. Once you have downloaded the file, double-click on the file name to begin the installation. InstallShield will install the files for you at a location you designate, and a pop-up **readme** file will explain the available options to add the files to your existing Dynamic C installation or to modify the relevant files in your existing Dynamic C installation.

You will be able to use the revamped Dynamic C installation with the RabbitNet peripheral card and you will continue to be able to use this installation with all the other Rabbit Semiconductor products you used before.

1.3.2 Sample Programs

Sample programs are provided in the Dynamic C **SAMPLES** folder.

The various folders contain specific sample programs that illustrate the use of the corresponding Dynamic C libraries. For example, the sample program **PONG.C** demonstrates the output to the **STDIO** window.

The **RABBITNET** folder provides sample programs specific to the RabbitNet peripheral cards. Each sample program has comments that describe the purpose and function of the program. Follow the instructions at the beginning of the sample program.

To run a sample program, open it with the **File** menu (if it is not still open), then compile and run it by pressing **F9** or by selecting **Run** in the **Run** menu. The RabbitNet peripheral card must be connected to a master such as the BL2500 with its Demonstration Board connected as explained in the *Coyote (BL2500) User's Manual* or other user's manual. The BL2500 or other master must be in Program Mode, and must be connected via the programming cable to a PC.

More complete information on Dynamic C is provided in the *Dynamic C User's Manual*.

1.3.3 General RabbitNet Operation

The **SAMPLES\RABBITNET** subdirectory contains the following sample programs. When running these sample programs, the RabbitNet peripheral card may be connected to either RabbitNet port on a master such as the BL2500 that has two RabbitNet ports. The sample program will use **rn_device()** to first look for peripheral cards connected to the master. The last peripheral card found will run the sample program. The sample program will also display the serial number(s) of the peripheral cards connected to which RabbitNet port on the master using the **STDIO** window, or that no card is connected to a particular port.

- **ECHOCHAR.C**—Demonstrates a simple character echo to any RabbitNet peripheral card. A character is sent to the RabbitNet peripheral card connected at a physical node address of 0x00 or 0000 octal. If a peripheral card is connected, the character will be returned back along with the status of the peripheral card. Otherwise, the status byte will indicate there is no connection.
- **ECHOTERM.C**—Demonstrates a simple character echo to any RabbitNet peripheral card through a serial terminal on the master. A character is sent to the RabbitNet peripheral card connected at a physical-node address of 0x00 or 0000 octal. If a card is connected, the character will be returned back along with the status of the peripheral card. Otherwise, the status byte will indicate there is no connection.
- **HWATCHDOG.C**—Demonstrates setting the hardware watchdog on a RabbitNet peripheral card. This sample program will first look for a peripheral card that matches the search criteria. The hardware watchdog will be set and a hardware reset should occur in approximately 1.5 seconds. The hardware watchdog will be disabled after the reset is done.
- **SWATCHDOG.C**—Demonstrates setting and hitting the software watchdog on a RabbitNet peripheral card using costatements. This program will first look for a peripheral card matching the search criteria. The software watchdog will be set for 2.5 seconds. The watchdog will be hit at every increasing timeout until the timeout is past 2.5 seconds. A software reset will occur and the software watchdog will be disabled.

1.3.4 General RabbitNet Function Calls

The function calls described in this section are used with all RabbitNet peripheral cards, and are available in the `RNET.LIB` library in the Dynamic C `RABBITNET` folder.

```
int rn_init(char portflag, char servicetype);
```

Resets, initializes, or disables a specified RabbitNet port on the master single-board computer. During initialization, the network is enumerated and relevant tables are filled in. If the port is already initialized, calling this function forces a re-enumeration of all devices on that port.

Call this function first before using other RabbitNet functions.

PARAMETERS

portflag is a bit that represents a RabbitNet port on the master single-board computer (from 0 to the maximum number of ports). A set bit requires a service. If **portflag** = 0x03, both RabbitNet ports 0 and 1 will need to be serviced.

servicetype enables or disables each RabbitNet port as set by the port flags.

0 = disable port

1 = enable port

RETURN VALUE

0

```
int rn_device(char pna);
```

Returns an address index to device information from a given physical node address. This function will check device information to determine that the peripheral card is connected to a master.

PARAMETER

pna is the physical node address, indicated as a byte.

7,6—2-bit binary representation of the port number on the master

5,4,3—Level 1 router downstream port

2,1,0—Level 2 router downstream port

RETURN VALUE

Pointer to device information. -1 indicates that the peripheral card either cannot be identified or is not connected to the master.

SEE ALSO

`rn_find`

```
int rn_find(rn_search *srch);
```

Locates the first active device that matches the search criteria.

PARAMETER

srch is the search criteria structure **rn_search**:

```
unsigned int flags;    // status flags see MATCH macros below
unsigned int ports;   // port bitmask
char pna              // physical node address
char productid;      // product id
char productrev;     // product rev
char coderev;        // code rev
long serialnum;      // serial number
```

Use a maximum of 3 macros for the search criteria:

```
RN_MATCH_PORT        // match port bitmask
RN_MATCH_PNA         // match physical node address
RN_MATCH_HANDLE      // match instance (reg 3)
RN_MATCH_PRDID       // match id/version (reg 1)
RN_MATCH_PRDREV      // match product revision
RN_MATCH_CODEREV     // match code revision
RN_MATCH_SN          // match serial number
```

For example:

```
rn_search newdev;
newdev.flags = RN_MATCH_PORT|RN_MATCH_SN;
newdev.ports = 0x03; // search ports 0 and 1
newdev.serialnum = E3446C01L;
handle = rn_find(&newdev);
```

RETURN VALUE

Returns the handle of the first device matching the criteria. -1 indicates no such devices were found.

SEE ALSO

rn_device

```
int rn_echo(int handle, char sendecho,
            char *recdata);
```

The peripheral card sends back the character the master sent. This function will check device information to determine that the peripheral card is connected to a master.

PARAMETERS

handle is an address index to device information. Use **rn_device()** or **rn_find()** to establish the handle.

sendecho is the character to echo back.

recdata is a pointer to the return address of the character from the device.

RETURN VALUE

The status byte from the previous command. -1 means that device information indicates the peripheral card is not connected to the master.

```
int rn_write(int handle, int regno, char *data,  
int datalen);
```

Writes a string to the specified device and register. Waits for results. This function will check device information to determine that the peripheral card is connected to a master.

PARAMETERS

handle is an address index to device information. Use `rn_device()` or `rn_find()` to establish the handle.

regno is the command register number as designated by each device.

data is a pointer to the address of the string to write to the device.

datalen is the number of bytes to write (0–15).

NOTE: A data length of 0 will transmit the one-byte command register number.

RETURN VALUE

The status byte from the previous command. -1 means that device information indicates the peripheral card is not connected to the master, and -2 means that the data length was greater than 15.

SEE ALSO

`rn_read`

```
int rn_read(int handle, int regno, char *reodata,  
int datalen);
```

Reads a string from the specified device and register. Waits for results. This function will check device information to determine that the peripheral card is connected to a master.

PARAMETERS

handle is an address index to device information. Use `rn_device()` or `rn_find()` to establish the handle.

regno is the command register number as designated by each device.

reodata is a pointer to the address of the string to read from the device.

datalen is the number of bytes to read (0–15).

NOTE: A data length of 0 will transmit the one-byte command register number.

RETURN VALUE

The status byte from the previous command. -1 means that device information indicates the peripheral card is not connected to the master, and -2 means that the data length was greater than 15.

SEE ALSO

`rn_write`

```
int rn_reset(int handle, int resettype);
```

Sends a reset sequence to the specified peripheral card. The reset takes approximately 25 ms before the peripheral card will once again execute the application. Allow 1.5 seconds after the reset has completed before accessing the peripheral card. This function will check peripheral card information to determine that the peripheral card is connected to a master.

PARAMETERS

handle is an address index to device information. Use **rn_device()** or **rn_find()** to establish the handle.

resettype describes the type of reset.

0 = hard reset—equivalent to power-up. All logic is reset.

1 = soft reset—only the microprocessor logic is reset.

RETURN VALUE

The status byte from the previous command. -1 means that device information indicates the peripheral card is not connected to the master.

```
int rn_sw_wdt(int handle, float timeout);
```

Sets software watchdog timeout period. Call this function prior to enabling the software watchdog timer. This function will check device information to determine that the peripheral card is connected to a master.

PARAMETERS

handle is an address index to device information. Use **rn_device()** or **rn_find()** to establish the handle.

timeout is a timeout period from 0.025 to 6.375 seconds in increments of 0.025 seconds. Entering a zero value will disable the software watchdog timer.

RETURN VALUE

The status byte from the previous command. -1 means that device information indicates the peripheral card is not connected to the master.

```
int rn_enable_wdt(int handle, int wdtttype);
```

Enables the hardware and/or software watchdog timers on a peripheral card. The software on the peripheral card will keep the hardware watchdog timer updated, but will hard reset if the time expires. The hardware watchdog cannot be disabled except by a hard reset on the peripheral card. The software watchdog timer must be updated by software on the master. The peripheral card will soft reset if the timeout set by `rn_sw_wdt()` expires. This function will check device information to determine that the peripheral card is connected to a master.

PARAMETERS

handle is an address index to device information. Use `rn_device()` or `rn_find()` to establish the handle.

wdtttype

- 0 enables both hardware and software watchdog timers
- 1 enables hardware watchdog timer
- 2 enables software watchdog timer

RETURN VALUE

The status byte from the previous command. -1 means that device information indicates the peripheral card is not connected to the master.

SEE ALSO

`rn_hitwd`, `rn_sw_wdt`

```
int rn_hitwd(int handle, char *count);
```

Hits software watchdog. Set the timeout period and enable the software watchdog prior to using this function. This function will check device information to determine that the peripheral card is connected to a master.

PARAMETERS

handle is an address index to device information. Use `rn_device()` or `rn_find()` to establish the handle.

count is a pointer to return the present count of the software watchdog timer. The equivalent time left in seconds can be determined from `count × 0.025` seconds.

RETURN VALUE

The status byte from the previous command. -1 means that device information indicates the peripheral card is not connected to the master.

SEE ALSO

`rn_enable_wdt`, `rn_sw_wdt`

```
int rn_rst_status(int handle, char *retdata);
```

Reads the status of which reset occurred and whether any watchdogs are enabled.

PARAMETERS

handle is an address index to device information. Use `rn_device()` or `rn_find()` to establish the handle.

retdata is a pointer to the return address of the communication byte. A set bit indicates which error occurred. This register is cleared when read.

- 7—HW reset has occurred
- 6—SW reset has occurred
- 5—HW watchdog enabled
- 4—SW watchdog enabled
- 3,2,1,0—Reserved

RETURN VALUE

The status byte from the previous command.

```
int rn_comm_status(int handle, char *retdata);
```

PARAMETERS

handle is an address index to device information. Use `rn_device()` or `rn_find()` to establish the handle.

retdata is a pointer to the return address of the communication byte. A set bit indicates which error occurred. This register is cleared when read.

- 7—Data available and waiting to be processed MOSI (master out, slave in)
- 6—Write collision MISO (master in, slave out)
- 5—Overrun MOSI (master out, slave in)
- 4—Mode fault, device detected hardware fault
- 3—Data compare error detected by device
- 2,1,0—Reserved

RETURN VALUE

The status byte from the previous command.

1.3.5 Status Byte

Unless otherwise specified, functions returning a status byte will have the following format for each designated bit.

7	6	5	4	3	2	1	0	
×	×							00 = Reserved 01 = Ready 10 = Busy 11 = Device not connected
		×						0 = Device 1 = Router
			×					0 = No error 1 = Communication error [*]
				×				Reserved for individual peripheral cards
					×			Reserved for individual peripheral cards
						×		0 = Last command accepted 1 = Last command unexecuted
							×	0 = Not expired 1 = HW or SW watchdog timer expired [†]

* Use the function `rn_comm_status()` to determine which error occurred.

† Use the function `rn_rst_status()` to determine which timer expired.

2. DIGITAL I/O CARD

Chapter 2 describes the features and the use of the Digital I/O Card, one of the peripheral cards designed for use with the RabbitNet expansion ports on selected Rabbit Semiconductor single-board computers, operator interfaces, and RabbitCore Prototyping Boards.

Figure 3 shows a conceptual view of the Digital I/O Card connected to a master.

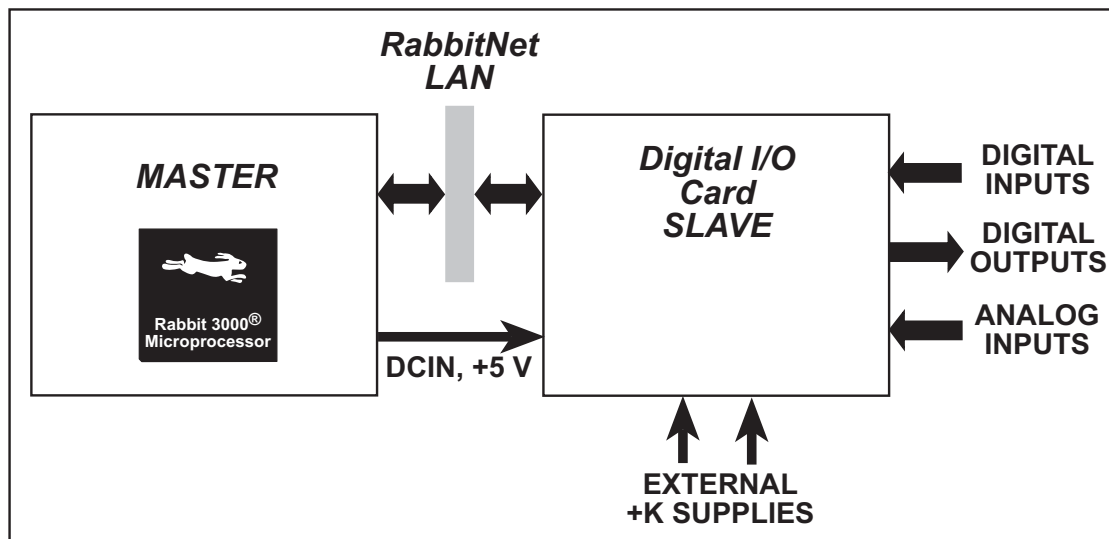

Figure 3. Digital I/O Card (Slave) Connected to Master

NOTE: The OP7200 master and the RabbitCore Prototyping Boards do *not* supply any power to the slave.

2.1 Features

- 24 protected and filtered digital inputs
- 16 high-speed protected digital outputs, individually configurable as sinking or sourcing up to 200 mA at up to 36 V DC
- four 10-bit analog input channels:
 - 2 buffered, 0 – 10 V, single-ended
 - 1 buffered, 0 – 1 V, single-ended
 - 1 buffered, -0.25 – +0.25 V, differential
- can be mounted in standard 100 mm DIN rail trays sold by other suppliers
- interfaces with master through RabbitNet™ serial protocol at 1 Megabit per second using standard CAT 5/6 Ethernet cable, can be up to 10 m (33 ft) away from master

2.1.1 Software

The Digital I/O Card is a slave; the master to which it is connected is programmed using version 8.01 or later of Rabbit Semiconductor's Dynamic C. If you are using a master with an earlier version of Dynamic C, Rabbit Semiconductor recommends that you upgrade your Dynamic C installation. Contact your authorized Rabbit Semiconductor distributor or your Rabbit Semiconductor Sales Representative for more information on Dynamic C upgrades.

2.2 Connections

Use a straight-through CAT 5/6 Ethernet cable to connect the Digital I/O Card's RJ-45 RabbitNet jack to a RabbitNet port on the master. You may use either port if you are connecting to a master such as the BL2500 that has more than one RabbitNet port.

NOTE: The RJ-45 *RabbitNet* jacks are serial I/O ports for use with a master and a network of peripheral cards. The *RabbitNet* jacks do not support Ethernet connections.

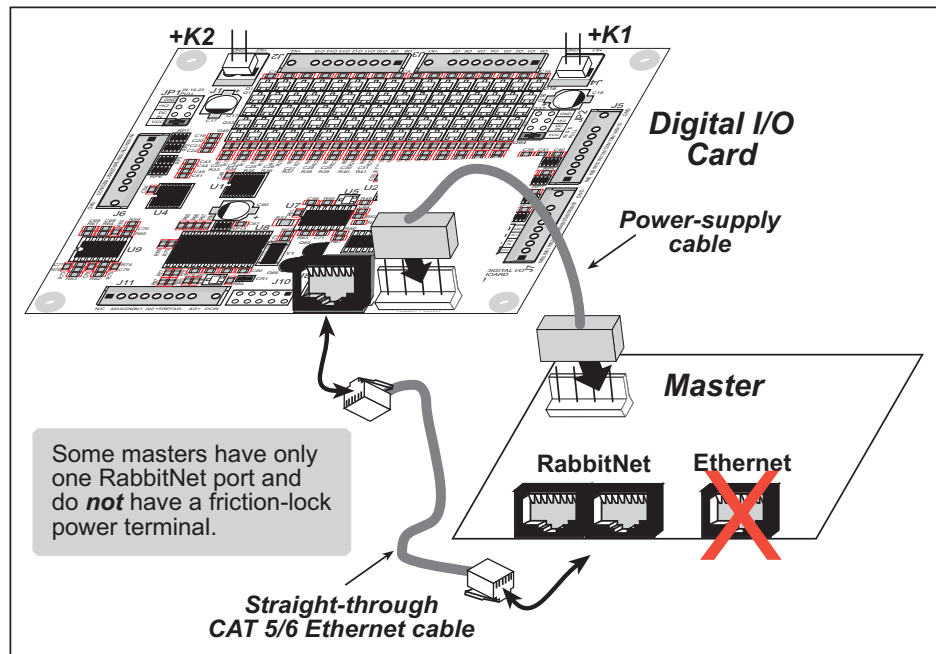

Figure 4. Connect Digital I/O Card to Master

You will also have to provide two separate DC power supplies to your Digital I/O Card: +5 V and a DCIN of 9–32 V. These power supplies are connected via the polarized friction-lock terminal at header J9. You may assemble a suitable cable using the friction-lock connectors from the Connectivity Kit described in Section 1.1.3. If you are using a BL2500 or BL2600 as your master, you may draw this power from the BL2500 or BL2600 as shown in Figure 4.

If you are using the digital outputs, you will need two additional external power supplies up to 36 V that can each handle up to 1.6 A for +K1 and +K2. The actual voltage and current depend on the requirements of the loads you plan to connect to the digital outputs. These power supplies are connected to friction-lock terminals J1 and J4 on the Digital I/O Card. You may assemble suitable cables using the friction-lock connectors from the Connectivity Kit described in Section 1.1.3. See Section 2.2.1 for detailed wiring diagrams.

2.2.1 Power Supply

Figure 5 illustrates the assembled friction-lock connector wiring diagram for the power supplies used to supply power to the Digital I/O Card.

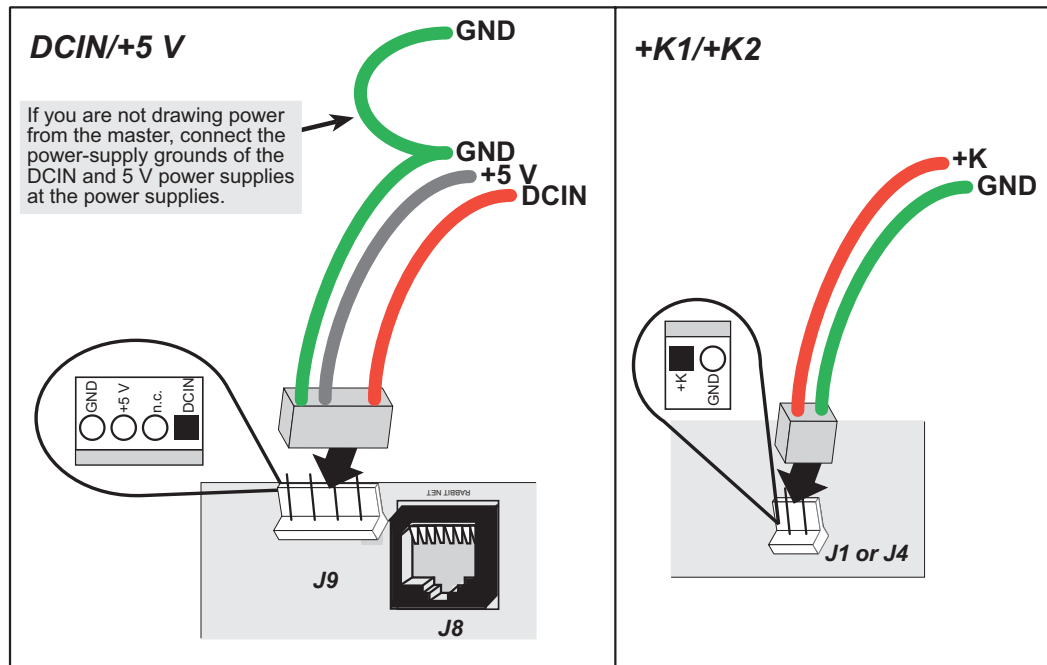

Figure 5. Power-Supply Connections

NOTE: If you are using separate DC power supplies for DCIN and +5 V because you are not drawing this power from the master, note that the crimp pins used in the fraction-lock connector assembly can only hold one wire each. Connect the one GND wire from the fraction-lock connector assembly to the ground on one of the two power supplies, then use a separate wire to connect the power-supply grounds together.

Use 18-gauge (AWG) wire for power-supply connections up to 10 m away from the master. If the wire length is less than 3 m, 22 gauge (AWG) wire is acceptable. Do not daisy-chain the power supply connections between different peripheral cards, but use a star configuration from the master or router when there are several peripheral cards.

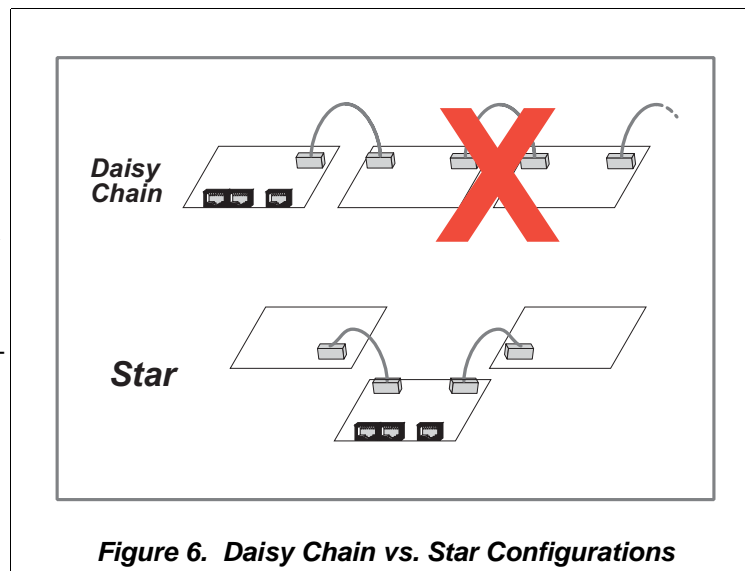

Figure 6. Daisy Chain vs. Star Configurations

It is best to use a type of cable where the wires for the ground and positive(s) of any power supply are bound together or twisted, and ideally the power-supply wires should not be bundled with other wires.

Large transient currents flow in the ground and positive supply wires when the digital output drivers are switched on/off, and it is imperative that any ground differential resulting from resistive or inductive loss in the ground wire be kept as low as possible (<4 V). Use the GND pin on header J1, J4, or J9 on the Digital I/O Card if you have separate power supplies. Rabbit Semiconductor also recommends that you have a physical ground connection between the Digital I/O Card and the master, which you will have if the power to header J9 on the Digital I/O Card already comes from the master.

For development purposes, it is possible to draw the +K1/+K2 power from DCIN, as long as you are careful to use only one digital output at a time to avoid exceeding the maximum current-output capability of the DCIN supply. You can use a 3-way or a 4-way splice (for example, Molex Series 19204), connector shells, or a terminal block to split the DCIN supply from the master. Remember to do the same for the GND.

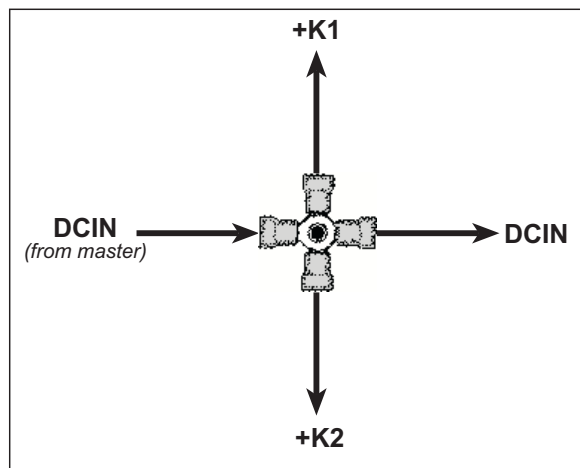

Figure 7. Example of 4-way Splice for DCIN (used for development purposes only)

2.3 Pinout

The Digital I/O Card pinouts are shown in Figure 8.

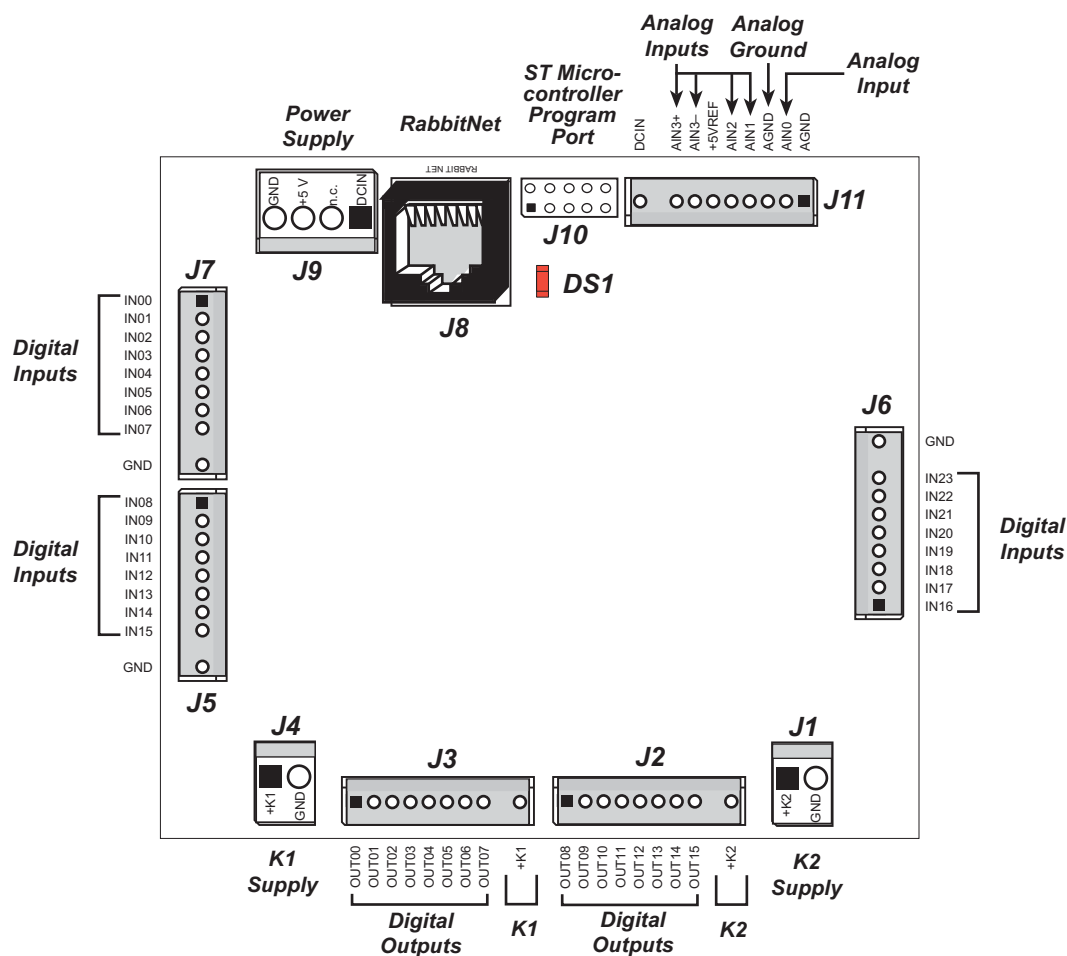

Figure 8. Digital I/O Card Pinouts

2.3.1 Headers

Digital I/O Cards are equipped with six polarized 1×9 friction-lock terminals (J2, J3, J5, J6, J7, and J11), a 1×4 friction-lock terminal (J9—DCIN and +5 V power supplies), two 1×2 friction-lock terminals (J1 and J4—external +K power supplies), and an RJ-45 RabbitNet jack.

No header is installed at J10, which is used to program the Digital I/O Card at the factory.

2.3.2 Indicator LED

An indicator LED (DS1) located under the header J10 location turns on when the Digital I/O Card is powered up, then goes off once the Digital I/O Card is running. The LED will flicker when the Digital I/O Card is receiving a transmission from the master.

2.4 Digital I/O

2.4.1 Digital Inputs

The Digital I/O Card has 24 digital inputs, IN00–IN23, each of which is protected over a range of -36 V to $+36\text{ V}$. The inputs are factory-configured to be pulled up to $+5\text{ V}$, but they can also be pulled up to DCIN or $+K1$ (IN00–IN15)/ $+K2$ (IN16–IN23) or down to 0 V in banks of eight by changing a jumper as shown in Figure 9. The locations of the headers and the jumper configurations are described in Section 2.7.2.

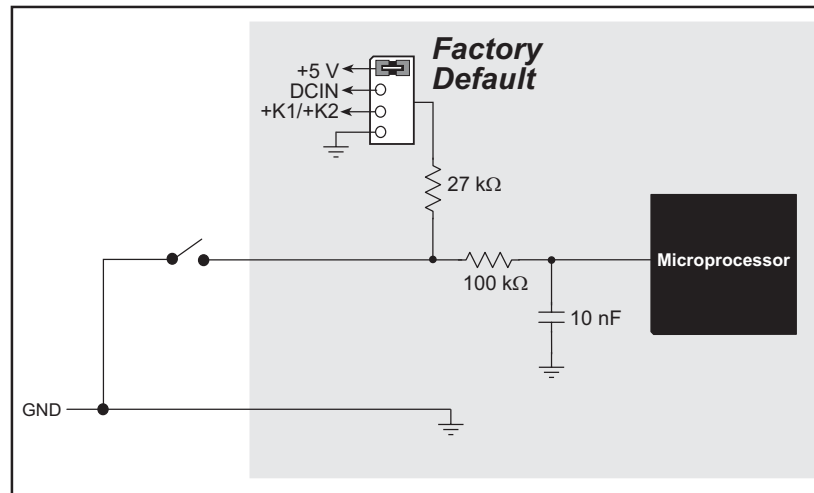

Figure 9. Digital I/O Card Digital Inputs [Pulled Up—Factory Default]

NOTE: If the inputs are pulled up to $+K1/+K2$, the voltage range over which the digital inputs are protected changes to $(K1/K2 - 36\text{ V})$ to $+36\text{ V}$ in order to keep the power dissipation through the pull-up resistor below the rated 62 mW .

The actual switching threshold is approximately 2.40 V . Anything below this value is a logic 0, and anything above is a logic 1.

The digital inputs are each fully protected over a range of -36 V to $+36\text{ V}$, and can handle short spikes of $\pm 40\text{ V}$.

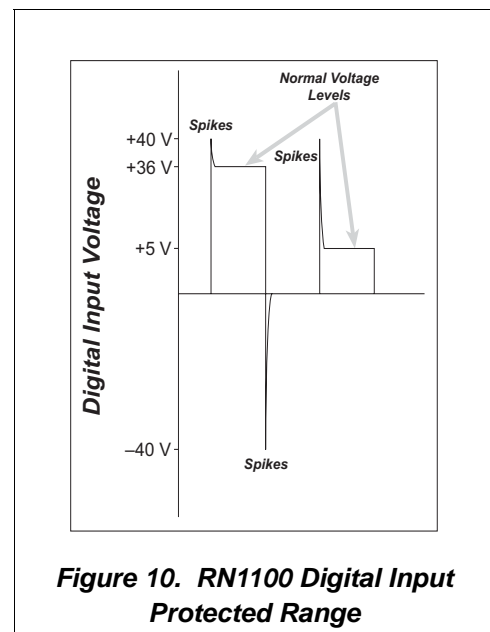

Figure 10. RN1100 Digital Input Protected Range

2.4.2 Digital Outputs

The Digital I/O Card has 16 digital outputs, OUT00–OUT15, which can each sink or source up to 200 mA. Figure 11 shows a wiring diagram for using the digital outputs in a sinking or a sourcing configuration.

The `rn_digOutConfig()` function call simultaneously configures all the output channels to a “safe state” on power-up for sinking or sourcing outputs by setting the channels to a high impedance. The “safe state” is considered to be all zeros, a disabled state for sourcing outputs.

All the digital outputs sink and source actively. They can be used as high-side drivers, low-side drivers, or as an H-bridge driver. When the Digital I/O Card is first powered up or reset, all the outputs are disabled, that is, at a high-impedance status, until the `rn_digOutConfig()` software function call is made. The `rn_digOutConfig()` call sets the initial state of each digital output according to the configuration specified by the user, and enables the digital outputs to their initial status.

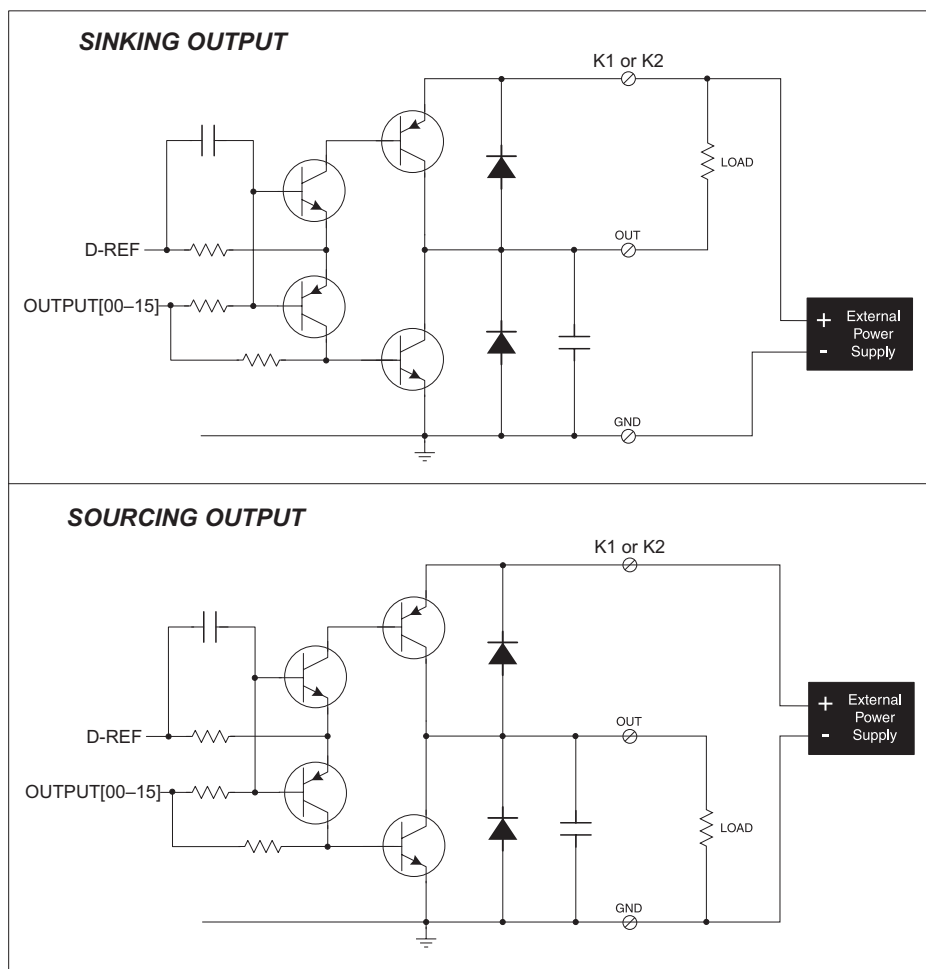

Figure 11. Digital I/O Card Digital Outputs

OUT00–OUT07 are powered by to +K1, and OUT08–OUT15 are powered by +K2. K1 and K2 can each be up to 36 V, and should be able to supply up to 1.6 A. +K1 and +K2 don't have to be same. The actual voltage depends on the requirements of the loads you plan to connect to the digital outputs.

All the sinking or sourcing current, which could be up to 1.6 A per bank of outputs, is returned through the GND pins. Be sure to use a suitably sized GND as explained in Section 2.2.1, and keep the distance to the power supply as short as possible.

For the H bridge, which is shown in Figure 12, K1 and K2 *should be the same* if two digital outputs used for the H bridge are on different banks.

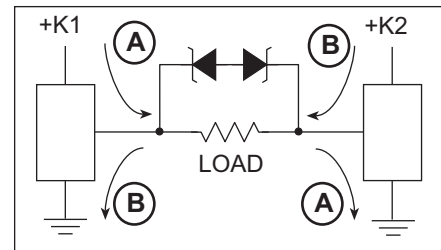

Figure 12. H Bridge

2.5 Analog Inputs

The microprocessor on the Digital I/O Card has four 10-bit A/D converter channels. Each channel is identical, and can convert a range of voltages between 0 V and V_{cc} , where V_{cc} is the +5 V reference that powers the microprocessor.

These four channels are configured as follows on the Digital I/O Card:

- 2 buffered channels, 0 – 10 V raw input voltage range, single-ended
- 1 buffered channel, 0 – 1 V raw input voltage range, single-ended
- 1 buffered channel, -0.25 – +0.25 V raw input voltage range, differential

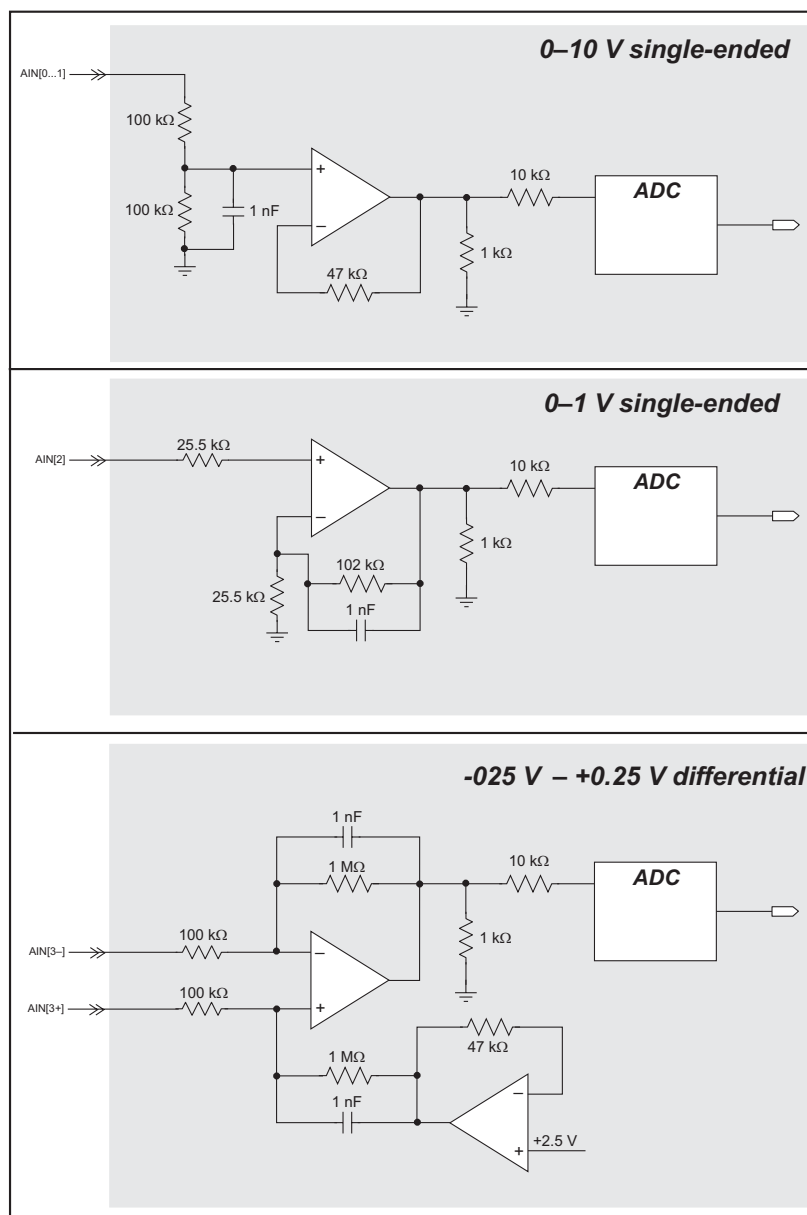

Figure 13. Digital I/O Card Analog Inputs

2.5.1 Single-Ended Inputs

There are three single-ended A/D converter inputs on the Digital I/O Card. A 5 V reference voltage is used for the single-ended inputs.

Two single-ended inputs that handle 0–10 V are filtered by a network of resistors and a capacitor. The resistors form a 2:1 attenuator, and the capacitor protects the A/D converter input against electrostatic transients. The input impedance is approximately 200 k Ω .

The third single-ended input handles 0–1 V and is filtered by a network of resistors and a capacitor, which stabilize the circuit against oscillation and electrostatic transients. The op-amp and feedback resistors form a $\times 5$ amplifier. The input impedance is of the order of several megohms.

2.5.2 Differential Inputs

Differential measurements actually require two analog inputs. As the name *differential* implies, the difference in voltage between the two inputs is measured rather than the difference between the input and ground.

A 2.5 V reference voltage is used for the differential inputs to shift the center point of operation to 2.5 V. The input impedance of each differential input is at least 1 M Ω .

The differential input circuit of the Digital I/O Card was designed to measure voltages over a range of ± 250 mV. If the negative input is -250 mV, and the positive input is +250 mV, the output to the A/D converter will be 5 V. If both inputs are tied together and to ground, the output to the A/D converter will be 2.5 V. The output to the A/D converter will drop to 0 V when the negative input reaches +250 mV and the positive input reaches -250 mV.

2.5.3 Calibrating the Analog Inputs

Manufacturing tolerances for resistors, bias currents, offset voltages, gain, and the like introduce errors into the A/D conversions. Ideally there would be a one-to-one straight-line relationship between the input voltage and the output of the A/D converter, and a graph of such a line would have a slope of 1 and would pass through the (0,0) coordinate. However, the errors arising from manufacturing tolerances introduce a deviation between the input voltage that is actually applied and the voltage measurement that is output by the A/D converter. The actual plot of voltage in vs. the voltage out from A/D converter is not actually a straight line. However, a straight line is a very good first-order approximation, and the calibration routines provided for the Digital I/O Card are based on a straight line with a slope of 1 and an offset from (0,0). The calibration routines use two known measurement points on the voltage-in vs. voltage-out line as the basis to calculate calibration constants that will be used to adjust for the slope of the line and the offset from (0,0). The calibration routines typically use input voltage points that are 10% of the voltage range less than the maximum and 10% of the voltage range more than the minimum readings possible for the A/D converter on any given range.

When calibrating the A/D converter, its output depends on the accuracy of the meter used to measure the voltage source used in the calibration process. Therefore, use the best digital voltmeter available that meets or exceeds the 10-bit accuracy of the A/D converter chip.

2.5.3.1 Calibration Constants

The A/D converter has four individual input channels available. To get the best results from the A/D converter, it is necessary to calibrate each channel. The following table provides a grid for each possible set of calibration constants.

	Single-Ended			Differential
Channel	AIN0	AIN1	AIN2	AIN3– AIN3+
Input				

When a calibration is performed, it fills in one of the squares in the table with a set of calibration constants representing the corresponding channel. These constants are stored in flash memory, and are thus maintained even when power is been removed from the Digital I/O Card.

The sample programs listed in the table below are provided to illustrate how to read and calibrate the various A/D inputs.

Mode	Read	Calibrate
Single-Ended, one channel	<code>AIN_RDSE_CH.C</code>	<code>AIN_CALSE_CH.C</code>
Differential, analog ground	<code>AIN_RDDIFF_CH.C</code>	<code>AIN_CALDIFF_CH.C</code>

These sample programs are found in the **AIN** subdirectory in **SAMPLES\RABBITNET\RN1100\ADC**. See Section 2.6.2, “Sample Programs,” for more information on these sample programs and how to use them.

2.5.3.2 Calibration Recommendations

Calibrate each of the A/D converter inputs in the same manner as they are to be used in the application. For example, if you will be performing floating differential measurements or differential measurements using a common analog ground, then calibrate the A/D converter in the corresponding manner.

It is not necessary to fill out the entire calibration table. Only the entries associated with the channels that you will be using are necessary. This will simplify and speed up the calibration process.

Each calibration is normally done at 10% less than the maximum and 10% more than the minimum within a given voltage range defined by the channel. However, if an application is known to use only portion of a particular range, it is possible to obtain improved accuracy by using calibration points that are 10% less than the expected maximum and 10% greater than the expected minimum.

2.5.3.3 Factory Calibration

Calibration constants are not measured and loaded at the factory for individual Digital I/O Cards. Default calibration constants (gain of 1, offset 0) are stored in flash memory, which will allow you to use the analog inputs with a typical accuracy of about 2%. This is sufficient for many closed-loop applications. Rabbit Semiconductor recommends that you calibrate your card as described above only if you have to get the highest accuracy possible when performing analog conversions.

2.6 Software

This section provides the libraries, function calls, and sample programs related to the Digital I/O Card.

2.6.1 Dynamic C Libraries

In addition to the library associated with the master, two other libraries have function calls for the Digital I/O Card.

- **RNET_DIO.LIB**—provides functions unique to the digital I/O on the Digital I/O Card. Function calls for this library are discussed in this chapter.
- **RNET_AIN.LIB**—provides functions unique to the analog inputs on the Digital I/O Card and the A/D Converter Card. Function calls for this library are discussed in this chapter.

Functions relevant to RabbitNet peripheral cards in general are described in Section 1.3.4. Other functions applicable to all devices based on Rabbit microprocessors are described in the *Dynamic C Function Reference User's Manual*.

2.6.2 Sample Programs

Sample programs are provided in the Dynamic C **SAMPLES** folder.

The various folders contain specific sample programs that illustrate the use of the corresponding Dynamic C libraries. For example, the sample program **PONG.C** demonstrates the output to the **STDIO** window.

To run a sample program, open it with the **File** menu (if it is not still open), then compile and run it by pressing **F9** or by selecting **Run** in the **Run** menu. The RabbitNet peripheral card must be connected to a master such as the BL2500 with its Demonstration Board connected as explained in the *Coyote (BL2500) User's Manual* or other user's manual. The BL2500 or other master must be in Program Mode, and must be connected via the programming cable to a PC.

2.6.2.1 Digital I/O

The **SAMPLES\RABBITNET\RN1100\DIO** subdirectory contains the following sample programs. When running these sample programs, the Digital I/O Card may be connected to either RabbitNet port on a master such as the BL2500 that has two RabbitNet ports. The sample program will use **rn_find()** and the product RN1100 as the search criteria to first find any Digital I/O Cards connected to the master. The first Digital I/O Card found will run the sample program.

- **DIGBANKIN.C**—Demonstrates the use of the digital inputs by using the Demonstration Board to read a bank of input channels while an individual channel is toggled from high to low by pressing a pushbutton switch on the Demonstration Board.

Before you run this sample program, connect +K1 and GND on connector J4 of the Digital I/O card to an external +5 V power supply. Make sure the digital inputs are pulled up with a jumper across pins 1–2 on headers JP1, JP2, and JP3. If you are not drawing power from

the master, you will also have to connect DCIN, +5 V, and GND from connector J9 on the Digital I/O Card to external power supplies.

On the Demonstration Board, check that the factory-default positioning of jumpers is across pins 3–5 and 4–6 of header H2.

Make the following connections from the Digital I/O Card to the Demonstration Board.

IN00 — S1
 IN01 — S2
 IN02 — S3
 IN03 — S4
 +K1 — +5 V
 GND — GND

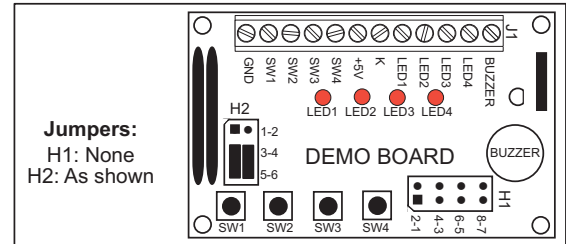

Once this sample program is compiled and running, you may press switches S1–S4 on the Demonstration Board to toggle the input low on the corresponding channel. Inputs IN04–IN23 can be toggled low by touching the line with a GND signal. The status of the inputs is displayed in the Dynamic C **STDIO** window.

- **DIGIN.C**—Demonstrates the use of the digital inputs by using the Demonstration Board to read individual input channels while an individual channel is toggled from high to low by pressing a pushbutton switch on the Demonstration Board.

Before you run this sample program, use the same power-supply connections and the same connections between the Digital I/O Card and the Demonstration Board as shown for the **DIGBANKIN.C** sample program.

Once **DIGIN.C** is compiled and running, you may press switches S1–S4 on the Demonstration Board to toggle the input low on the corresponding channel. Inputs IN04–IN23 can be toggled low by touching the line with a GND signal. The status of the inputs is displayed in the Dynamic C **STDIO** window.

- **DIGBANKOUT.C**—Demonstrates writing values to a bank of outputs by using the Demonstration Board whose LEDs are toggled on/off via the outputs.

Before you run this sample program, connect +K1 and GND on connector J4 of the Digital I/O Card to an external +5 V power supply. If you are not drawing power from the master, you will also have to connect DCIN, +5 V, and GND from connector J9 on the Digital I/O Card to external power supplies.

Make the following connections from the Digital I/O Card to the Demonstration Board.

- OUT00 — DS1
 OUT01 — DS2
 OUT02 — DS3
 OUT03 — DS4
 +K1 — +5 V
 GND — GND

Once this sample program is compiled and running, the Dynamic C **STDIO** window will prompt to select an output bank. Select 1 for outputs OUT00–OUT07. Next you will be prompted to enter a hex byte value—for example, enter AA to toggle LEDs DS1 and DS3 on/off.

- **DIGOUT.C**—Demonstrates the use of the outputs by using the Demonstration Board whose LEDs are toggled on/off via the outputs.

Before you run this sample program, use the same power-supply connections and the same connections between the Digital I/O Card and the Demonstration Board as for the **DIG-BANKOUT.C** sample program.

Once **DIGOUT.C** is compiled and running, the Dynamic C **STDIO** window will prompt you for a channel selection. Select output channel OUT00. Next you will be prompted to select the logic level—set a high logic level to turn LED DS1 on. You can repeat these steps for OUT01–OUT03 and LEDs DS2–DS4. You can use a voltmeter to check the voltages on the remaining outputs.

2.6.2.2 Analog Inputs

The **SAMPLES\RABBITNET\RN1100\AIN** subdirectory contains the following sample programs. The sample program will use `rn_find()` and the product RN1100 as the search criteria to first find any Digital I/O Cards connected to the master. The first Digital I/O Card found will run the sample program.

NOTE: The Demonstration Board does not have to be connected to run these sample programs.

- **AIN_CALDIFF.CH.C**—Demonstrates how to recalibrate the differential A/D converter channel using two known voltages to generate constants for that channel that are rewritten into the Digital I/O Card flash memory. The voltages being monitored will be displayed continuously.

Before you run this sample program, connect a 0–10 V power supply, a voltmeter, and a network of resistors to inputs AIN03+ and AIN03– as shown in the diagram. Adjust the power supply starting at 0 V until the voltmeter shows approximately +0.235 V at AIN03+.

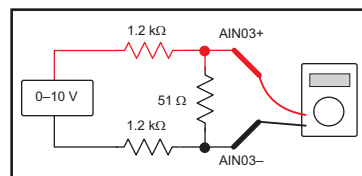

Now compile and run the sample program. Enter the voltage reading when prompted by the Dynamic C **STDIO** window. Then reverse the power supply + and – connections and hit the **Return** key in the Dynamic C **STDIO** window. Now enter the voltage reading again.

- **AIN_CALSE.CH.C**—Demonstrates how to recalibrate one single-ended A/D converter channel using two known voltages to generate constants for that channel that are rewritten into the Digital I/O Card flash. The voltages being monitored will be displayed continuously.

Before you run this sample program, connect a 0–10 V power supply and a voltmeter between the selected analog channel and ground. Now compile and run the sample program. Follow the prompts in the Dynamic C **STDIO** window.

- **AIN_RDDIFF.CH.C**—Demonstrates reading the differential A/D converter channel using two known voltages and constants for that channel. The voltage being monitored will be displayed continuously.

Before you run this sample program, connect a 0–10 V power supply, a voltmeter, and a network of resistors to inputs AIN03+ and AIN03– as shown for the **AIN_CALDIFF.CH.C** sample program. Adjust the power supply on until the voltmeter shows approximately +0.20 V at AIN03+.

Now compile and run the sample program. Vary the voltage from 0 to +0.25V and observe the voltage readings on the voltmeter and in the Dynamic C **STDIO** window. Then reverse the power supply + and – connections. Again vary the voltage from 0 to +0.25V and observe the voltage readings on the voltmeter and in the Dynamic C **STDIO** window.

- **AIN_RDSE_CH.C**—Reads and displays the voltage and equivalent values of one single-ended analog input channel. Coefficients are read from the Digital I/O Card. The computed raw data and equivalent voltages will be displayed.

Before you run this sample program, connect a 0–10 V power supply between analog input AIN00 or AIN01 and GND. Connect a second 0–1 V power supply between analog input AIN02 and GND. Now compile and run the sample program. Follow the prompts in the Dynamic C **STDIO** window.

- **AIN_SAMPLE.C**—Demonstrates how to use the A/D driver on the single-ended inputs. The voltage (average of 10 samples) that is present on the A/D channels will be displayed continuously.

Before you run this sample program, connect a 0–10 V power supply and a voltmeter between the analog input and GND of the analog input channel you will be using. The analog input voltage range can be 0–10 V for AIN00 and AIN01, 0–1 V for AIN02, and ± 0.25 V for AIN03.

Now power up the master and the Digital I/O Card, and compile and run the sample program. Vary the voltage from the power supply over the design range for the channel you are using and observe the voltmeter reading and the reading displayed in the Dynamic C **STDIO** window.

2.6.3 Digital I/O Card Function Calls

2.6.3.1 Digital Input Function Calls

```
int rn_digIn(int handle, int channel,
             char *retdata, int reserved);
```

Reads the undeglinted or raw data state of the selected digital input channel.

PARAMETERS

handle is an address index to device information. Use `rn_device()` or `rn_find()` to establish the handle.

channel is the digital input channel (0–23) to read.

retdata is a pointer to the return data address of the logic state.

reserved is reserved for future use. Set to 0.

RETURN VALUE

The status byte from the previous command, and a pointer to the return data logic state (0 or 1) of the input. -1 means that device information indicates the Digital I/O Card is not connected to the master.

SEE ALSO

`rn_digOut`, `rn_digBankIn`

```
int rn_digBankIn(int handle, int bank,
                 char *retdata, int reserved);
```

Reads the undeglinted or raw data state of a block of designated digital input channels. The first bank consists of channels 0–7, the second bank consists of channels 8–15, and the third bank consists of channels 16–23.

PARAMETERS

handle is an address index to device information. Use `rn_device()` or `rn_find()` to establish the handle.

bank is the bank to read.

0 for all banks on the card

1 for bank of digital inputs 0–7

2 for bank of digital inputs 8–15

3 for bank of digital inputs 16–23

retdata is a pointer to the return data address of the logic state.

reserved is reserved for future use. Set to 0.

RETURN VALUE

The status byte from previous command, and a pointer to the return data byte where each bit corresponds to one channel. Channels 0, 8, and 16 are considered to be the bit 0 positions. If all the banks are requested, the pointer to the bank 1 data byte is returned with subsequent byte pointers to the next two banks. -1 means that device information indicates the Digital I/O Card is not connected to the master.

SEE ALSO

`rn_digIn`, `rn_digBankOut`

2.6.3.2 Digital Output Function Calls

```
int rn_digOutConfig(int handle, int senddata);
```

Configures output channels 0 to 15 to a “safe state” on power-up for sinking or sourcing outputs. The channels are set to a high impedance at power-up. The factory default sets the safe state as zeros, considered a disabled state for sourcing outputs.

This function will first compare the requested states and values in the “safe state” register. If there is a match, the requested states will not be rewritten to the device to eliminate unnecessary writes. Otherwise this function saves states to flash, and therefore should be called only once. A hardware reset, `rn_reset()`, and a read of the reset register, `rn_rst_status()`, must be issued after this function is called.

PARAMETERS

handle is an address index to device information. Use `rn_device()` or `rn_find()` to establish the handle.

senddata is a bitwise logic representing a state of 0 or 1 for each channel. The most significant bit represents channel 15.

- 0 = disable sourcing outputs
- 1 = disable sinking outputs

RETURN VALUE

The status byte from the previous command. -1 means that device information indicates the Digital I/O Card is not connected to the master.

SEE ALSO

`rn_digOut`

```
int rn_digOut(int handle, int channel,  
char senddata, int reserved);
```

Sets the state of a digital output.

PARAMETERS

handle is an address index to device information. Use `rn_device()` or `rn_find()` to establish the handle.

channel is the output channel number (0 to 15)

senddata is the output data.

- 1 = set bit
- 0 = reset bit

reserved is reserved for future use. Set to 0.

RETURN VALUE

The status byte from the previous command. -1 means that device information indicates the Digital I/O Card is not connected to the master.

SEE ALSO

`rn_digOutConfig`, `rn_digBankOut`, `rn_digIn`

```
int rn_digBankOut(int handle, int bank,  
char senddata, int reserved);
```

Writes the state of a block of designated digital output channels. The first bank consists of channels 0–7, and the second bank consists of channels 8–15.

PARAMETERS

handle is an address index to device information. Use `rn_device()` or `rn_find()` to establish the handle.

bank is the bank of digital output channels to write.

0 for all the digital outputs 0 to 15 in both banks

1 for bank of digital outputs 0 to 7

2 for bank of digital outputs 8 to 15

senddata is a 16-bit output value, where each bit corresponds to one channel. Channel 0 and channel 8 are considered the least significant bit 0 when using single-bank access. When accessing both banks, channel 0 is the least significant bit 0 and channel 15 is the most significant bit 15.

reserved is reserved for future use. Set to 0.

RETURN VALUE

The status byte from the previous command. -1 means that device information indicates the Digital I/O Card is not connected to the master.

SEE ALSO

`rn_digOutConfig`, `rn_digOut`, `rn_digBankIn`

2.6.3.3 Analog Input Function Calls

```
int rn_anaInConfig(int handle, int channel,  
int opmode, int gaincode, int reserved);
```

Configures each analog input channel to the desired operation at the desired gain. Once all channels have been set to single-ended voltages or differential voltages, use `rn_anaIn()`, `rn_anaInVolts()`, or `rn_anaInDiff()` to read an A/D converter channel.

PARAMETERS

handle is an address index to device information. Use `rn_device()` or `rn_find()` to establish the handle.

channel is the channel number (0 to3).

Channel	Single-Ended	Differential
0	+AIN0	—
1	+AIN1	—
2	+AIN2	—
3	—	+AIN3 -AIN3

opmode is the mode of operation for the specified channel:

ADCENABLE—enables conversions

ADCDISABLE—disables conversions

gaincode is the gain code. Use 0 for the Digital I/O Card.

reserved is reserved for future use. Set to 0.

RETURN VALUE

The status byte from the previous command. -1 means that device information indicates the Digital I/O Card is not connected to the master.

SEE ALSO

`rn_anaIn`, `rn_anaInVolts`, `rn_anaInDiff`

```
int rn_anaIn(int handle, int channel, int *retdata,
             int sample, int reserved);
```

Reads the raw data value of an analog input channel. Set the **sample** parameter greater than one to average the readings.

PARAMETERS

handle is an address index to device information. Use `rn_device()` or `rn_find()` to establish the handle.

channel is the channel number (0 to 3).

Channel	Voltage Range
0	0 to +10 V
1	0 to +10 V
2	0 to +1 V
3	±250 mV

retdata is a pointer to the return address of a raw data value (0–1023) for 10-bit A/D conversions

sample is x number of samples

1 sample = approximately 500 μ s

>1 sample = each sampling will wait for an updated conversion—this may take 40 to 160 μ s longer depending on how many channels are enabled

reserved is reserved for future use. Set to 0.

RETURN VALUE

The status byte from the previous command and a return pointer to the raw input data. -1 means that device information indicates the Digital I/O Card is not connected to the master.

SEE ALSO

`rn_anaInConfig`, `rn_anaInVolts`, `rn_anaInDiff`

```
int rn_anaInVolts(int handle, int channel,
                 float *retdata, int sample, int reserved);
```

Reads the state of a single-ended analog input channel. Set the **sample** parameter greater than one to average the readings.

PARAMETERS

handle is an address index to device information. Use `rn_device()` or `rn_find()` to establish the handle.

channel is the channel number (0 to 2).

Channel	Voltage Range
0	0 to +10 V
1	0 to +10 V
2	0 to +1 V

retdata is a pointer to a floating-point voltage value, which is updated for the channel being accessed (represented in units of volts)

NOTE: If there is a data overflow or an out-of-range error, the value will be set to -4096 (as defined by the macro `ADOVERFLOW`).

sample is x number of samples

1 sample = approximately 675 μ s

>1 sample = each sampling will wait for an updated conversion—this may take 40 to 160 μ s longer depending on how many channels are enabled

reserved is reserved for future use. Set to 0.

RETURN VALUE

The status byte from the previous command and a return pointer to the raw input data. -1 means that device information indicates the Digital I/O Card is not connected to the master.

SEE ALSO

`rn_anaInConfig`, `rn_anaIn`, `rn_anaInDiff`

```
int rn_anaInDiff(int handle, int channel,
                float *retdata, int sample, int reserved);
```

Reads the state of a differential analog input channel. Set the **sample** parameter greater than one to average the readings.

PARAMETERS

handle is an address index to device information. Use `rn_device()` or `rn_find()` to establish the handle.

channel is the channel number (3).

retdata is a pointer to a floating-point voltage value, which is updated for the channel being accessed (represented in units of volts)

NOTE: If there is a data overflow or an out-of-range error, the value will be set to -4096 (as defined by the macro `ADOVERFLOW`).

sample is x number of samples

1 sample = approximately 675 μ s

>1 sample = each sampling will wait for an updated conversion—this may take 40 to 160 μ s longer depending on how many channels are enabled

reserved is reserved for future use. Set to 0.

RETURN VALUE

The status byte from the previous command and a return pointer to the raw input data. -1 means that device information indicates the Digital I/O Card is not connected to the master.

SEE ALSO

`rn_anaInConfig`, `rn_anaIn`, `rn_anaInVolts`

```
int rn_anaInCalib(int channel, int opmode,
  int gaincode, int value1, float volts1,
  int value2, float volts2, rn_AinData *adata);
```

Calibrates the response of an analog input channel as a linear function using the two conversion points provided. Four values are calculated, and the results are sent later to the analog input device using the function `anaInWrCalib()`.

Each channel will have the following information:

- a linear constant or gain,
- a voltage offset.

NOTE: Typical calibration constants are loaded at the factory. This function should be used when you need more precise calibration or recalibration, or the calibration constants were corrupted in the device.

PARAMETERS

channel is the channel number (0 to3).

Channel	Single-Ended	Differential
0	AIN00	—
1	AIN01	—
2	AIN02	—
3	—	AIN03

opmode is not used. Set to 0.

gaincode is the gain code. Use 0 for the Digital I/O Card.

value1 is the first raw data value read from the A/D converter channel.

volts1 is the voltage corresponding to the first input value (0 to +10 V, 0 to +1 V, or ± 250 mV).

value2 is the second raw data value read from the A/D converter channel.

volts2 is the voltage corresponding to the second input value (0 to +10 V, 0 to +1 V, or ± 250 mV).

rn_AinData *adata is a structure pointer to where the calibration constants, gain, and offset values are to be written after being calculated.

RETURN VALUE

- 0, if successful.
- 1 if not able to make calibration constants.

SEE ALSO

`rn_anaInWrCalib`

```
int rn_anaInWrCalib(int handle, int channel,
    int opmode, int gaincode, rn_AinData adata,
    int reserved);
```

Writes the calibration constants, gain, and offset previously calculated by `rn_anaInCalib()` into the analog device flash memory. A hardware reset (`rn_reset()`) and a read reset register (`rn_rst_status()`) must be issued after this function is called.

NOTE: Typical calibration constants are loaded at the factory. This function should be used when you need more precise calibration or recalibration, or the calibration constants were corrupted in the device.

PARAMETERS

handle is an address index to device information. Use `rn_device()` or `rn_find()` to establish the handle.

channel is the channel number (0 to 3).

Channel	Single-Ended	Differential
0	AIN00	—
1	AIN01	—
2	AIN02	—
3	—	AIN03

opmode is not used. Set to 0.

gaincode is the gain code. Use 0 for the Digital I/O Card.

rn_AinData adata is a structure pointer to where the calibration constants, gain, and offset values are to be written after being calculated.

reserved is reserved for future use. Set to 0.

RETURN VALUE

The status byte from the previous command and a return pointer to the raw input data. -1 means that device information indicates the Digital I/O Card is not connected to the master.

SEE ALSO

`rn_anaInRdCalib`, `rn_anaInCalib`

```
int rn_anaInRdCalib(int handle, int channel,
    int opmode, int gaincode, rn_AinData *adata,
    int reserved);
```

Reads the calibration constants, gain, and offset from the analog input device.

PARAMETERS

handle is an address index to device information. Use `rn_device()` or `rn_find()` to establish the handle.

channel is the channel number (0 to3).

Channel	Single-Ended	Differential
0	AIN00	—
1	AIN01	—
2	AIN02	—
3	—	AIN03

opmode is not used. Set to 0.

gaincode is the gain code. Use 0 for the Digital I/O Card.

rn_AinData *adata is a structure pointer to where the calibration constants, gain, and offset values are to be written after being calculated.

reserved is reserved for future use. Set to 0.

RETURN VALUE

The status byte from the previous command and a return pointer to the raw input data. -1 means that device information indicates the Digital I/O Card is not connected to the master.

SEE ALSO

`rn_anaInWrCalib`, `rn_anaInCalib`

2.6.4 Status Byte

Section 1.3.5 provides information on the status bytes returned by various function calls.

2.7 Specifications

2.7.1 Electrical and Mechanical Specifications

Figure 14 shows the mechanical dimensions for the Digital I/O Card.

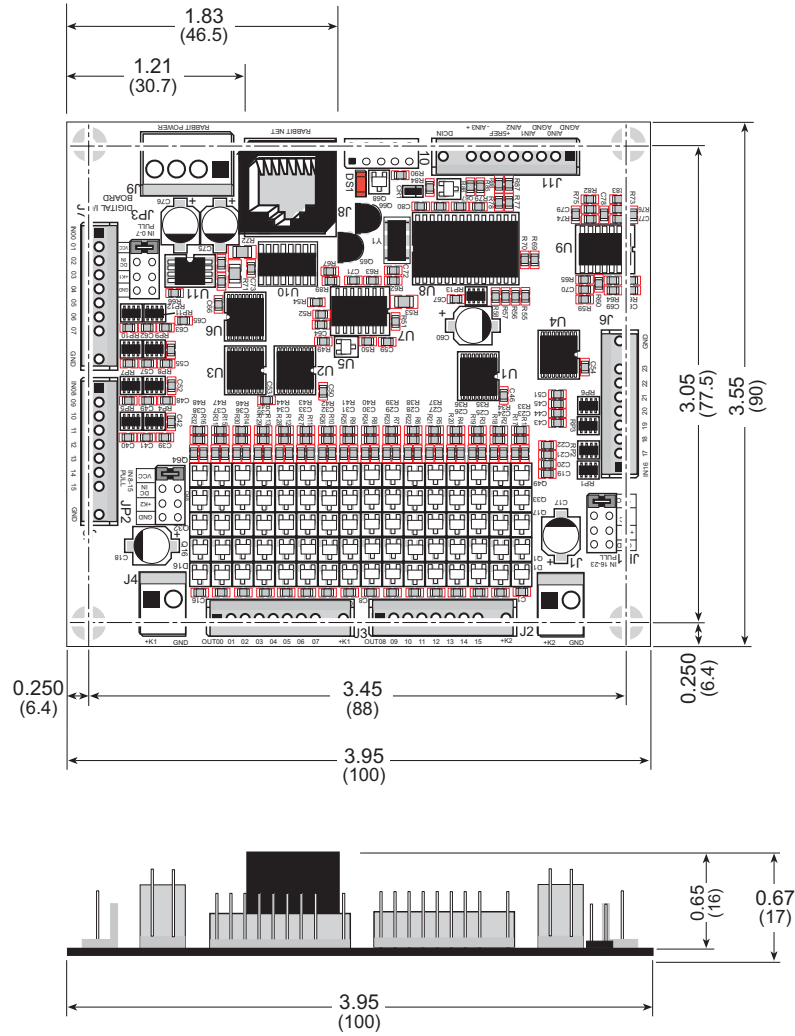

Figure 14. Digital I/O Card Dimensions

NOTE: All diagram and graphic measurements are in inches followed by millimeters enclosed in parentheses.

Table 3 lists the electrical, mechanical, and environmental specifications for the Digital I/O Card.

Table 3. Digital I/O Card Specifications

Feature	Specification
Microprocessor	ST72F264G
Digital Inputs	24, protected to ± 40 V DC, switching threshold is 1.5 V nominal
Digital Outputs	16, sink or source up to 200 mA each, 40 V DC max., individually software-configurable as sinking or sourcing
Analog Inputs	Four buffered channels: 10-bit resolution, 8-bit accuracy, conversion time 28 μ s/channel Input ranges: 2 channels 0–10 V, single-ended 1 channel 0–1 V, single-ended 1 channel -0.25 – +0.25 V, differential
RabbitNet™ Serial Port	RS-422, 1 Mbits/s
Power	Vcc: +5 V DC, 20 mA DCIN: 9–32 V DC (12 V min. if using analog inputs), 500 mW +K1, +K2: 5–36 V DC, 1.6 A each
Temperature	-40°C to +70°C
Humidity	5% to 95%, noncondensing
Connectors	Friction-lock connectors: six polarized 9-position terminals with 0.1" pitch two 2-position power terminals with 0.156" pitch one 4-position terminal with 0.156" pitch One RJ-45 RabbitNet™ jack
Board Size	3.55" \times 3.95" \times 0.67" (90 mm \times 100 mm \times 17 mm)

2.7.1.1 Physical Mounting

Figure 15 shows position information to assist with interfacing other boards with the Digital I/O Card.

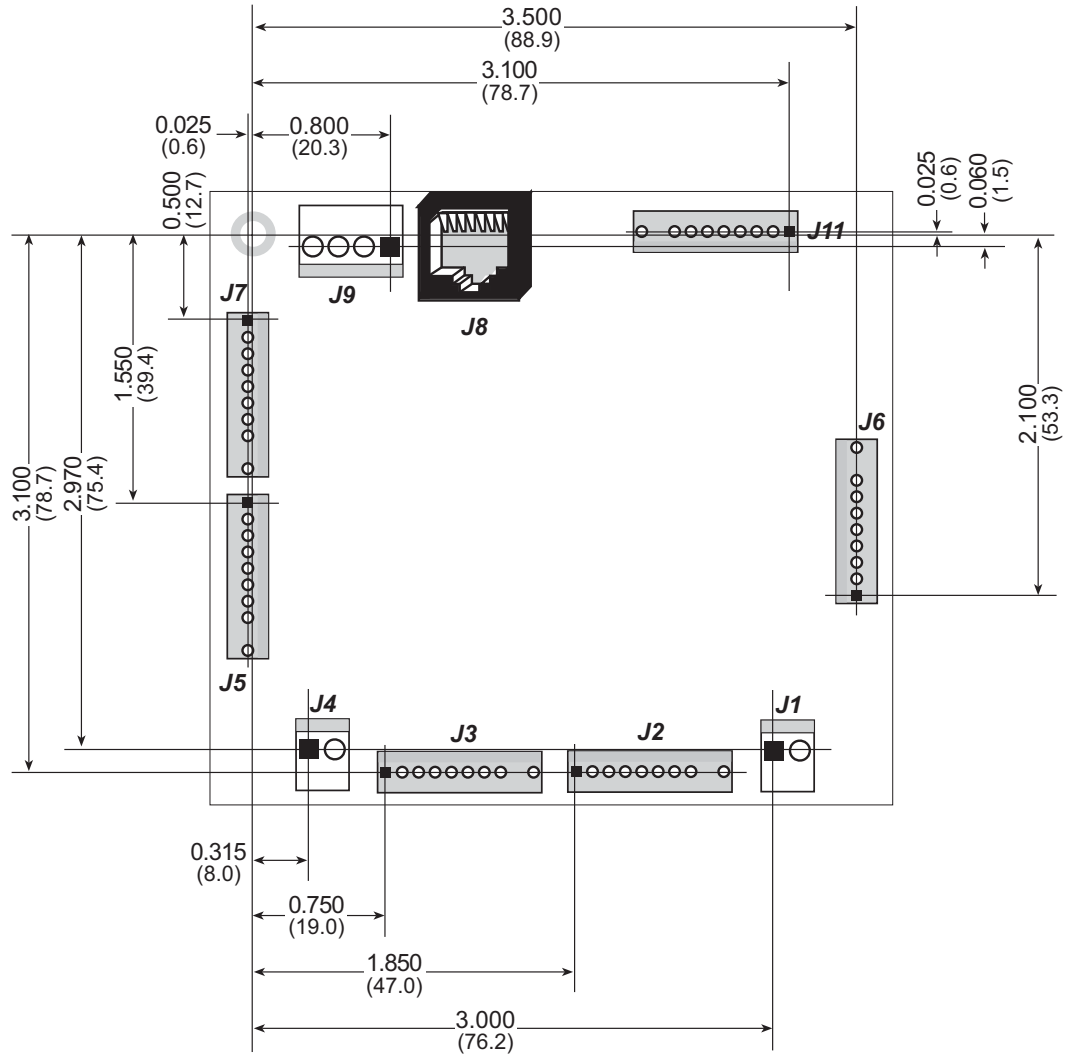

Figure 15. User Board Footprint for Digital I/O Card

2.7.2 Jumper Configurations

Figure 16 shows the header and jumper locations used to configure the various Digital I/O Card options.

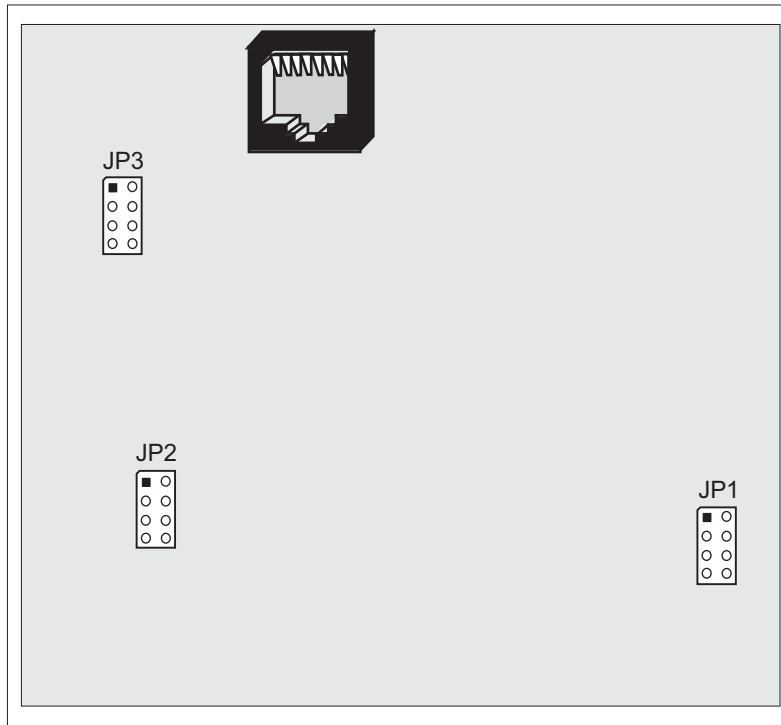

Figure 16. Location of Digital I/O Card Configurable Positions

Table 4 lists the configuration options. Standard pluggable jumpers are used.

Table 4. Digital I/O Card Jumper Configurations

Header	Description	Pins Connected		Factory Default
JP1	IN16–IN23	1–2	Pulled up to +5 V	×
		3–4	Pulled up to DCIN	
		5–6	Pulled up to +K2	
		7–8	Pulled down	
JP2	IN08–IN15	1–2	Pulled up to +5 V	×
		3–4	Pulled up to DCIN	
		5–6	Pulled up to +K1	
		7–8	Pulled down	
JP3	IN00–IN07	1–2	Pulled up to +5 V	×
		3–4	Pulled up to DCIN	
		5–6	Pulled up to +K1	
		7–8	Pulled down	

3. A/D CONVERTER CARD

Chapter 3 describes the features and the use of the A/D Converter Card, one of the peripheral cards designed for use with the RabbitNet expansion ports on selected Rabbit Semiconductor single-board computers, operator interfaces, and RabbitCore Prototyping Boards.

Figure 17 shows a conceptual view of the A/D Converter Card connected to a master.

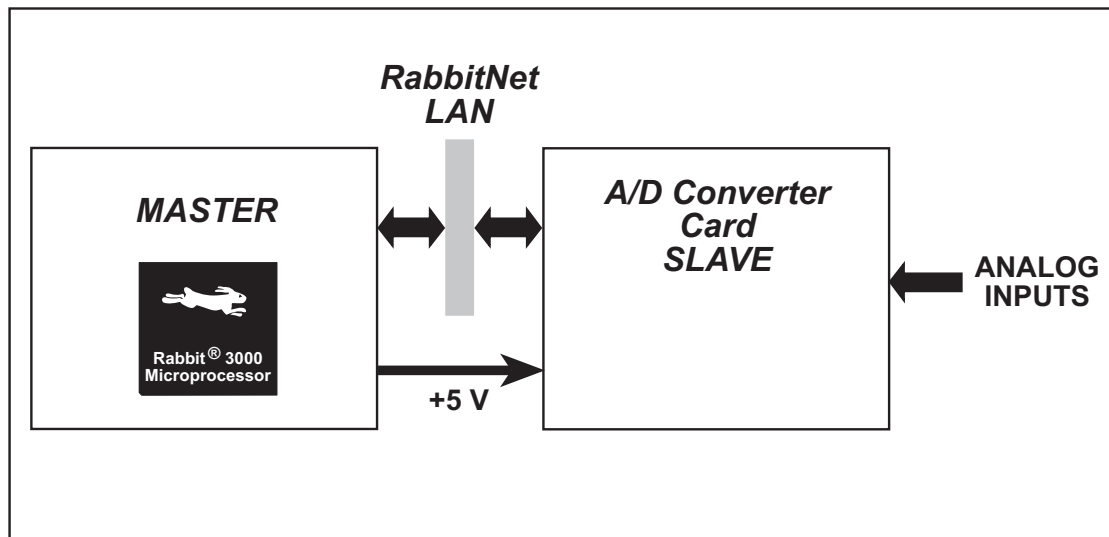

Figure 17. A/D Converter Card (Slave) Connected to Master

NOTE: The OP7200 master and the RabbitCore Prototyping Boards do *not* supply any power to the slave.

3.1 Features

- 8 single-ended 11-bit or 4 differential 12-bit analog inputs
- 4 channels can be set with jumpers to be 11-bit 4–20 mA analog inputs, all 8 channels can be special-ordered in quantity to be 11-bit 4–20 mA analog inputs
- 1 M Ω input impedance
- 2.5 ksamples/s sampling rate
- software-controlled voltage ranges: 0–1 V, 2 V, 5 V, 10 V, 20 V DC (single-ended) or ± 1 V, ± 2 V, ± 5 V, ± 10 V, ± 20 V DC (differential)
- can be mounted in standard 100 mm DIN rail trays sold by other suppliers
- interfaces with master through RabbitNet™ serial protocol at 1 Megabit per second using standard Ethernet cable up to 10 m (33 ft) long

3.1.1 Software

The A/D Converter Card is a slave; the master to which it is connected is programmed using version 8.01 or later of Rabbit Semiconductor's Dynamic C. If you are using a BL2500 or an OP7200 as your master with an earlier version of Dynamic C, Rabbit Semiconductor recommends that you upgrade your Dynamic C installation. Contact your authorized Rabbit Semiconductor distributor or your Rabbit Semiconductor Sales Representative for more information on Dynamic C upgrades.

3.2 Connections

Use a straight-through CAT 5/6 Ethernet cable to connect the A/D Converter Card's RJ-45 RabbitNet jack to a RabbitNet port on the master. You may use either port if you are connecting to a master such as the BL2500 that has more than one RabbitNet port.

NOTE: The RJ-45 *RabbitNet* jacks are serial I/O ports for use with a master and a network of peripheral boards. The *RabbitNet* jacks do *not* support Ethernet connections.

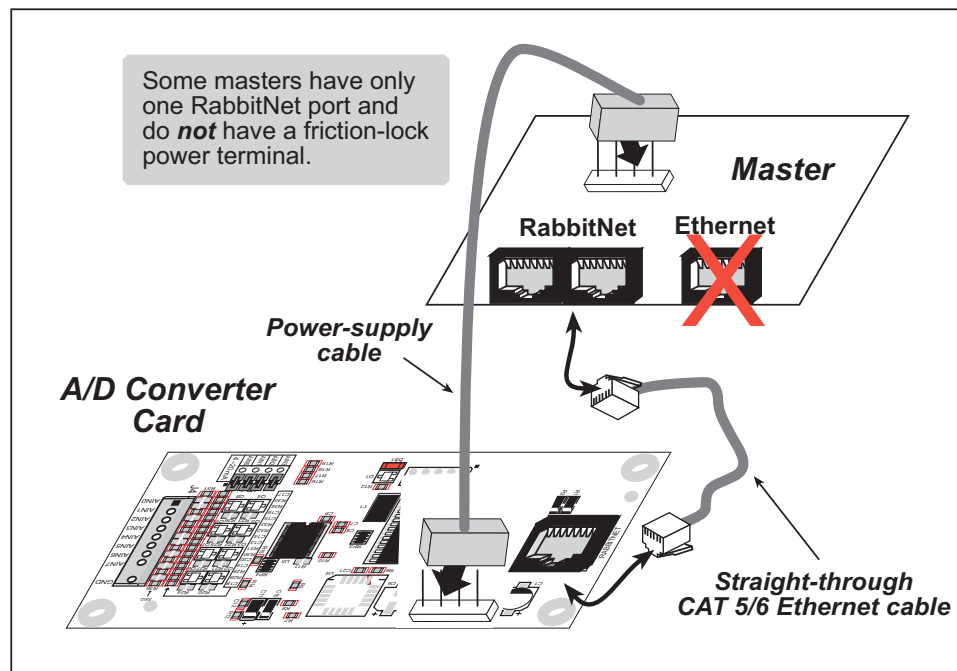

Figure 18. Connect A/D Converter Card to Master

You will also have to provide +5 V DC power to your A/D Converter Card. The power supply is connected via the friction-lock terminal at header J2. If you are using a BL2500 or BL2600 as your master, you may draw this power from the BL2500 or BL2600 as shown in Figure 18. You may assemble a suitable cable using the friction-lock connectors from the Connectivity Kit described in Section 1.1.3. Although there is a standard RabbitNet DCIN power-supply input on the A/D Converter Card, the A/D Converter Card does not need DCIN power.

NOTE: Even if you are not drawing power from a master, you will need to connect the A/D Converter Card ground to the ground on your master. The GND pin on header J2 should be used.

At the present time, you are limited by the number of RabbitNet ports on the master as to how many peripheral boards may be connected to that master.

3.2.1 Power Supply

Figure 19 illustrates the assembled friction-lock connector wiring diagram for the power supplies used to supply power to the A/D Converter Card.

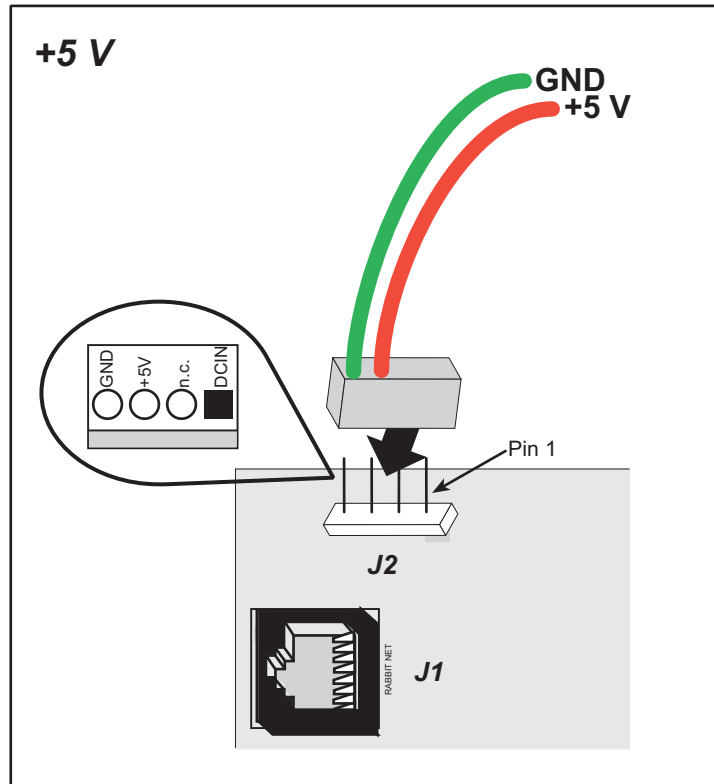

Figure 19. Power-Supply Connections

3.3 Pinout

The A/D Converter Card pinouts are shown in Figure 20.

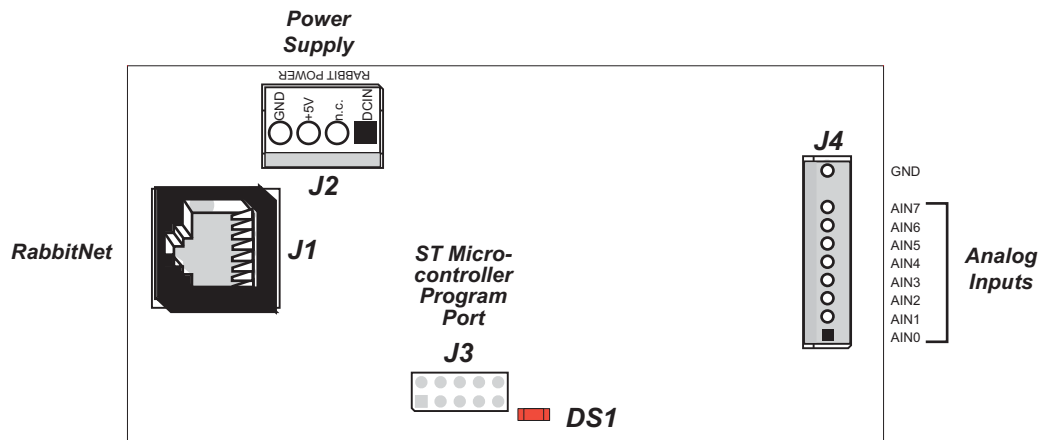

Figure 20. A/D Converter Card Pinouts

3.3.1 Headers

A/D Converter Cards are equipped with one polarized 1 × 9 friction-lock terminals at J4, a 1 × 4 friction-lock terminal at J2 (DCIN and +5 V power supplies), and an RJ-45 RabbitNet jack.

No header is installed at J3, which is used to program the A/D Converter Card at the factory.

3.3.2 Indicator LED

An indicator LED (DS1) located near the header J3 location turns on when the A/D Converter Card is powered up, then goes off when the A/D Converter Card has completed its initialization process and is running. The LED will be on while the A/D Converter Card is receiving a transmission from the master.

3.4 Analog Inputs

The single A/D converter used in the A/D Converter Card has a resolution of 11 bits (single-ended mode) or 12 bits (differential mode). There are eight channels of A/D conversion; the differential mode uses two channels for each differential-mode input.

Figure 21 shows a pair of A/D converter input circuits. Each A/D converter input essentially consists of resistors and a capacitor. The resistors form a 10:1 attenuator, and the capacitor protects the A/D converter input against electrostatic discharges.

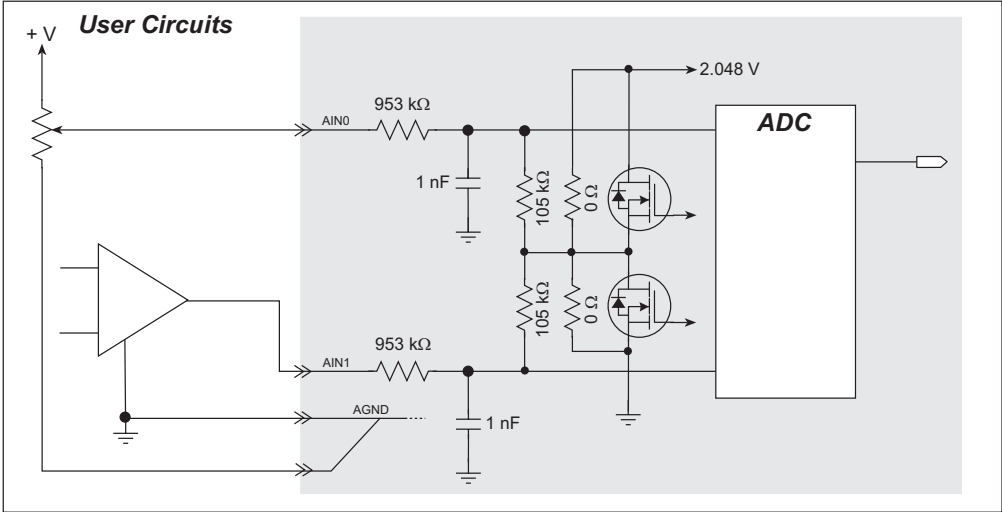

Figure 21. A/D Converter Inputs

The A/D converter chip can make either single-ended or differential measurements depending on the value of the `opmode` parameter in the software function call, which turns the appropriate MOSFETs on or off and configures the A/D converter chip. Adjacent A/D converter inputs are paired when you make differential measurements. For single-ended conversions, the A/D converter chip works only with positive voltages for the ranges listed in Table 5.

Table 5. Positive A/D Converter Input Voltage Ranges

Min. Voltage (V)	Max. Voltage (V)	Amplifier Gain	mV per Tick
0.0	+20.0	1	10
0.0	+10.0	2	5
0.0	+5.0	4	2.5
0.0	+4.0	5	2.0
0.0	+2.5	8	1.25
0.0	+2.0	10	1.0
0.0	+1.25	16	0.625
0.0	+1.0	20	0.500

Many other possible ranges are possible by physically changing the resistor values that make up the attenuator circuit.

Differential measurements require two channels. As the name *differential* implies, the difference in voltage between the two adjacent channels is measured rather than the difference between the input and analog ground. Voltage measurements taken in the differential mode have a resolution of 12 bits, with the 12th bit indicating whether the difference is positive or negative.

When using the differential mode, the input can be either positive or negative, but *do not* exceed the maximum range by more than 20%.

If a device such as a battery is connected across two channels for a differential measurement, and it is *not* referenced to analog ground, then the current from the device will flow through both sets of attenuator resistors as shown in Figure 22. This will generate a negative voltage at one of the inputs, ADC1, which will almost certainly lead to inaccurate A/D conversions. To allow for such differential measurements, the A/D Converter Card uses a 2.048 V reference voltage. This allows input voltages that are negative with respect to analog ground. Table 6 provides the differential voltage ranges for this setup.

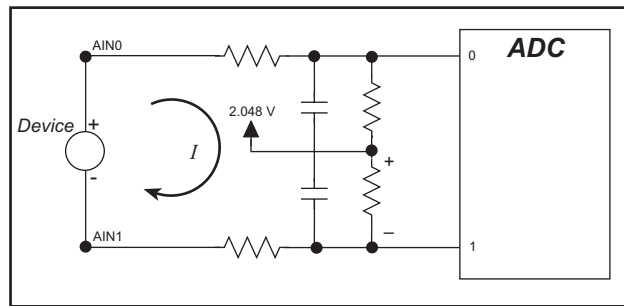

Figure 22. Current Flow from Ungrounded or Floating Source

differential measurements, the A/D Converter Card uses a 2.048 V reference voltage. This allows input voltages that are negative with respect to analog ground. Table 6 provides the differential voltage ranges for this setup.

Table 6. Differential Voltage Ranges

Min. Differential Voltage (V)	Max. Differential Voltage (V)	Amplifier Gain	mV per Tick
0	±20.0	×1	10
0	±10.0	×2	5
0	±5.0	×4	2.5
0	±4.0	×5	2.0
0	±2.5	×8	1.25
0	±2.0	×10	1.00
0	±1.25	×16	0.625
0	±1.0	×20	0.500

The differential mode described above may also be used to measure negative voltages.

3.4.1 Analog Current Measurements

The A/D converter inputs can also be used with 4–20 mA current sources by measuring the resulting analog voltage drop across a 100 Ω 1% precision resistor. These 100 Ω 1% precision resistors are included on the A/D Converter Card for analog input channels AIN0–AIN3, and each of these channels may be configured individually using the jumpers on header JP1 as shown in Figure 23.

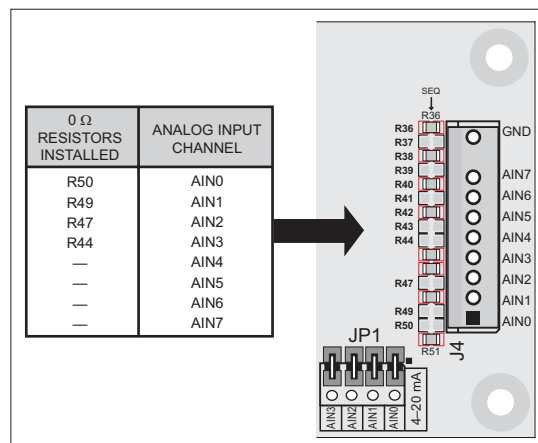

Figure 23. Locations of Resistors for 4–20 mA Mode



CAUTION: The input impedance is low for the 4–20 mA current mode. Be careful not to exceed 2.5 V across the input when using the 4–20 mA current mode to keep the power dissipation by the 100 Ω precision resistors below their maximum rating.

For volume orders of A/D Converter Cards configured as 4–20 mA analog inputs, 0 Ω surface-mounted resistors can be installed at the factory instead of the jumpers on header JP1, and AIN4–AIN7 can also be configured for use as 4–20 mA analog inputs. Contact your Rabbit Semiconductor Sales representative or your authorized distributor for more information on these options and the minimum order quantity.

The single-ended scale of 0–2.56 V with a gain of 8 is used to get an A/D current conversion of 12.5 μ A/tick.

3.4.2 Calibrating the A/D Converter Chip

Manufacturing tolerances for resistors, bias currents, offset voltages, gain, and the like introduce errors into the A/D conversions. Ideally there would be a one-to-one straight-line relationship between the input voltage and the output of the A/D converter, and a graph of such a line would have a slope of 1 and would pass through the (0,0) coordinate. However, the errors arising from manufacturing tolerances introduce a deviation between the applied input voltage and the voltage that is output by the A/D converter. The actual plot of voltage in vs. the voltage out from A/D converter is not actually a straight line. However, a straight line is a very good first-order approximation, and the calibration routines provided for the A/D Converter Card are based on a straight line with a slope of 1 and an offset from (0,0). The calibration routines use two known measurement points on the voltage-in vs. voltage-out line as the basis to calculate calibration constants that will be used to adjust for the slope of the line and the offset from (0,0). The calibration routines typically use input voltage points that are 10% less than the maximum and 10% more than the minimum readings possible for the A/D converter on any given range.

Quality calibration procedures are extremely important in obtaining good A/D converter results. No matter how high a resolution the A/D converter has, it cannot compensate for improper calibration. A/D converter results will never be more accurate than the meter used in the calibration process. Therefore, use the best digital volt and milli-amp meter available that meets or exceeds the accuracy of the A/D converter chip.

3.4.2.1 Modes

The A/D converter operates in three different modes:

- the single-ended mode,
- the differential mode, and
- the 4–20 mA current mode

The calibration and read routines provided correspond to these three modes.

3.4.2.2 Calibration Constants

The A/D converter has eight individual input channels, and each channel has eight programmable gains. Additionally, the A/D converter has the capability for adjacent inputs to be paired to make differential measurements with eight different gains, and provision is also made to convert 4–20 mA analog current measurements.

To get the best results from the A/D converter, it is necessary to calibrate each mode for each of its gains. The following table provides a grid for each possible set of calibration constants.

		Mode																
		Single-Ended								mA	Differential							
Gain		1	2	4	5	8	10	16	20	4	1	2	4	5	8	10	16	20
Input	0																	
	1																	
	2																	
	3																	
	4																	
	5																	
	6																	
	7																	

For the single-ended mode there are calibration constants for each channel and for each of its gains, for a total of 64 sets of calibration constants. The 4–20 mA mode covers 4–20 mA (actually 0–25 mA) currents. Separate calibration and read-back routines are provided for this. Since only one range of current measurement is provided, these routines use only one gain (4). One set of calibration constants is provided for each of the eight input channels. The differential-mode routines use a pair of input channels to make measurements. In this case, calibration constants are stored for each pair of channels and for each of the eight gains, for a total of 32 sets of calibration constants.

When a calibration is performed, it fills in one of the squares in the table with a set of calibration constants representing the corresponding mode, channel, and gain. These constants are stored in flash memory on the A/D Converter Card, and are thus maintained even when power is removed from the A/D Converter Card. Note that calibration constants are stored for each of the modes. Since A/D converter read routines select the appropriate calibration constants based on the mode, it is possible for software calls to move from one mode to another without recalibration.

3.4.2.3 Calibration Recommendations

It is imperative that you calibrate each of the A/D converter inputs in the same manner as they are to be used in the application. For example, if you will be performing floating differential measurements or differential measurements using a common analog ground, then calibrate the A/D converter in the corresponding manner. The calibration table only holds calibration constants based on mode, channel, and gain. ***Other factors affecting the calibration must be taken into account by calibrating using the same method, mode, and gain setup as in the intended use.***

It is not necessary to fill out the entire calibration table. Only the entries associated with the modes, channels, and gains that you will be using are necessary. This fact can be used to simplify and speed up the calibration process.

Each calibration is normally done at 10% less than the maximum and 10% more than the minimum within a given voltage range defined by the mode, channel, and gain. However, if an application is known to use only portion of a particular range, it is possible to obtain improved accuracy by using calibration points that are 10% less than the expected maximum and 10% greater than the expected minimum.

3.4.2.4 Factory Calibration

Because of the large number of possible calibrations, the factory performs only a rudimentary calibration on the A/D Converter Card. The factory performs a single-ended calibration on each of the eight channels with a gain of 1 (0–20 V range). The remaining single-ended calibration constants for the other seven gains are approximated and are filled in based on the initial calibration. The milli-amp and differential portions of the table are filled in using typical expected values. All read routines will work properly with these factory-initialized calibration constants, but only the single-ended mode should be expected to return accurate results over a range of 0–20 V until you recalibrate the A/D Converter Card for your use.

Sample programs are provided to illustrate how to read and calibrate the various A/D inputs.

Mode	Read	Calibrate
Single-Ended, one channel	<code>AIN_RDSE_CH.C</code>	<code>AIN_CALSE_CH.C</code>
Single-Ended, all channels	–	<code>AIN_CALSE_ALL.C</code>
4–20 mA Current	<code>AIN_RDMA_CH.C</code>	<code>AIN_CALMA_CH.C</code>
Differential	<code>AIN_RDDIFF_CH.C</code>	<code>AIN_CALDIFF_CH.C</code>

These sample programs are found in the in the `SAMPLES\RABBITNET\RN1200` directory. See Section 3.5.2, “Sample Programs,” for more information on these sample programs and how to use them.

3.5 Software

This section provides the libraries, function calls, and sample programs related to the A/D Converter Card.

3.5.1 Dynamic C Libraries

In addition to the library associated with the master single-board computer such as the BL2500 or OP7200, one other library is needed to provide function calls for the A/D Converter Card.

- **RNET_AIN.LIB**—provides functions unique to the analog inputs on the Digital I/O Card and the A/D Converter Card. Function calls for this library are discussed in this chapter.

Functions relevant to RabbitNet peripheral cards in general are described in Section 1.3.4. Other functions applicable to all devices based on Rabbit microprocessors are described in the *Dynamic C Function Reference User's Manual*.

3.5.2 Sample Programs

Sample programs are provided in the Dynamic C **SAMPLES** folder.

The various folders contain specific sample programs that illustrate the use of the corresponding Dynamic C libraries. For example, the sample program **PONG.C** demonstrates the output to the **STDIO** window.

To run a sample program, open it with the **File** menu (if it is not still open), then compile and run it by pressing **F9** or by selecting **Run** in the **Run** menu. The RabbitNet peripheral card must be connected to a master such as the BL2500 with its Demonstration Board connected as explained in the *Coyote (BL2500) User's Manual* or other user's manual. The BL2500 or other master must be in Program Mode, and must be connected via the programming cable to a PC.

The **SAMPLES\RABBITNET\RN1200** subdirectory contains the following sample programs. When running these sample programs, the A/D Converter Card may be connected to either RabbitNet port on a master such as the BL2500 that has two RabbitNet ports. The sample program will use **rn_find()** and the product RN1200 as the search criteria to first find any A/D Converter Cards connected to the master. The first A/D Converter Card found will run the sample program.

- **AIN_CALDIFF_CH.C**—Demonstrates how to recalibrate a differential A/D converter channel using two known voltages to generate constants for that channel that are rewritten into the A/D Converter Card flash memory. The voltages being monitored will be displayed continuously.

Before you run this sample program, make sure your 0–10 V external power supply is off and is set to 0 V. Connect the power supply to one of the differential channel pairs such as +AIN0 and –AIN1.

Now power up the master and the A/D Converter Card, and compile and run the sample program. Turn the external power supply on and follow the prompts in the Dynamic C **STDIO** window.

- **AIN_CALMA_CH.C**—Demonstrates how to recalibrate a 4–20 mA A/D converter channel using two known currents to generate constants for that channel that are rewritten into the A/D Converter Card flash memory. The currents being monitored will be displayed continuously.

Before you run this sample program, place jumpers across pins 1–2, 3–4, 5–6, and 7–8 of header JP1 on the A/D Converter Card. Connect an external power supply (make sure the power supply is set at 0 V and is turned off) between one of the analog input channels and GND with a 500 Ω resistor and an ammeter connected as shown in the diagram. If you do not use the 500 Ω resistor to simulate a 4–20 mA current source from a voltage swing of 0–10 V, your power supply voltage output cannot exceed 2.0 V.

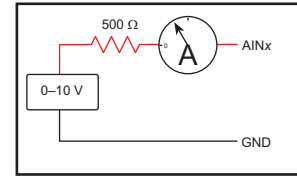

Now power up the master and the A/D Converter Card, and compile and run the sample program. Turn the external power supply on and follow the prompts in the Dynamic C **STDIO** window.

- **AIN_CASE_ALL.C**—Demonstrates how to recalibrate all the single-ended A/D converter channels for one gain using two known voltages to generate constants for each channel that are rewritten into the A/D Converter Card flash memory. A hardware reset will be issued to complete writes to flash memory once the constants are written, and the hardware watchdog will be set.

Before you run this sample program, make sure your 0–10 V external power supply is off and is set to 0 V. Connect the power supply between one of the AIN00–AIN07 analog channels and GND. Connect a voltmeter across the power-supply connections.

Now power up the master and the A/D Converter Card, and compile and run the sample program. Turn the external power supply on and follow the prompts in the Dynamic C **STDIO** window.

- **AIN_CASE_CH.C**—Demonstrates how to recalibrate one single-ended A/D converter channel using two known voltages to generate constants for that channel that are rewritten into the A/D Converter Card flash memory. A hardware reset will be issued to complete writes to flash memory once the constants are written, and the hardware watchdog will be set.

Before you run this sample program, make sure your 0–10 V external power supply is off and is set to 0 V. Connect the power supply between one of the AIN00–AIN07 analog channels and GND. Connect a voltmeter across the power supply connections.

Now power up the master and the A/D Converter Card, and compile and run the sample program. Turn the external power supply on and follow the prompts in the Dynamic C **STDIO** window.

- **AIN_RDDIFF_CH.C**—Demonstrates reading a differential A/D converter channel using two known voltages and constants for that channel. The voltage being monitored will be displayed continuously in the **STDIO** window.

Before you run this sample program, make sure your 0–10 V floating-point external power supply is off and is set to 0 V. Connect the power supply to one of the differential channel pairs such as +AIN0 and –AIN1.

Now power up the master and the A/D Converter Card, and compile and run the sample program. Turn the external power supply on and follow the prompts in the Dynamic C **STDIO** window.

- **AIN_RDMA_CH.C**—Demonstrates reading a 4–20 mA A/D converter channel. The current being monitored will be displayed continuously in the **STDIO** window.

Before you run this sample program, place jumpers across pins 1–2, 3–4, 5–6, and 7–8 of header JP1 on the A/D Converter Card. Connect an external power supply (make sure the power supply is set at 0 V and is turned off) between one of the analog input channels and GND with a 500 Ω resistor and an ammeter connected as shown for the **AIN_CALMA_CH.C** sample program. If you do not use the 500 Ω resistor to simulate a 4–20 mA current source from a voltage swing of 0–10 V, your power supply voltage output cannot exceed 2.0 V.

Now power up the master and the A/D Converter Card, and compile and run the sample program. Turn the external power supply on and follow the prompts in the Dynamic C **STDIO** window.

- **AIN_RDSE_ALL.C**—Reads and displays the voltage and equivalent values of all single-ended analog input channels. Coefficients are read from the A/D Converter Card. The computed raw data and equivalent voltages will be displayed.

Before you run this sample program, make sure your 0–10 V external power supply is off and is set to 0 V. Connect the power supply between one of the AIN00–AIN07 analog channels and GND. Connect a voltmeter across the power supply connections.

Now power up the master and the A/D Converter Card, and compile and run the sample program. Turn the external power supply on and follow the prompts in the Dynamic C **STDIO** window.

- **AIN_RDSE_CH.C**—Reads and displays the voltage and equivalent values of one single-ended analog input channel. Coefficients are read from the A/D Converter Card. The computed raw data and equivalent voltages will be displayed.

Before you run this sample program, make sure your 0–10 V external power supply is off and is set to 0 V. Connect the power supply between one of the AIN00–AIN07 analog channels and GND. Connect a voltmeter across the power supply connections.

Now power up the master and the A/D Converter Card, and compile and run the sample program. Turn the external power supply on and follow the prompts in the Dynamic C **STDIO** window.

- **AIN_READ_CALDATA.C**—Dumps the calibration data for all the A/D converter channels and the modes of operation. The calibration gain factor, offset values, and mode of operation will be displayed for each channel via the Dynamic C **STDIO** window.

3.5.3 A/D Converter Card Function Calls

```
int rn_anaInConfig(int handle, int channel,  
int opmode, int gaincode, int reserved);
```

Configures each analog input channel to the desired operation at the desired gain. Once all channels have been set to single-ended voltages, differential voltages, or current, use `rn_anaIn()`, `rn_anaInVolts()`, `rn_anaInmAmps()`, or `rn_anaInDiff()` to read an A/D converter channel.

PARAMETERS

handle is an address index to device information. Use `rn_device()` or `rn_find()` to establish the handle.

channel is the analog input channel number (0 to 7) corresponding to AIN0–AIN7

channel	SINGLE	DIFF	mAMP
0	+AIN0	+AIN0 -AIN1	+AIN0
1	+AIN1	—	+AIN1
2	+AIN2	+AIN2 -AIN3	+AIN2
3	+AIN3	—	+AIN3
4	+AIN4	+AIN4 -AIN5	+AIN4*
5	+AIN5	—	+AIN5*
6	+AIN6	+AIN6 -AIN7	+AIN6*
7	+AIN7	—	+AIN7*

* These channels need to be configured for current measurements as explained in Section 3.4.1.

opmode is the mode of operation for the specified channel. Use one of the following macros to set the mode for the channel being configured.

RNSINGLE—single-ended input line, background sampling enabled

RNDIFF—differential input line, background sampling enabled

RNmAMP—4–20 mA input line, background sampling enabled

gaincode is the gain code of 0 to 7 (use a gain code of 4 for 4–20 mA operation)

Gain Code	Multiplier	Voltage Range	
		Single-Ended	Differential
0	×1	0–20 V	± 20 V
1	×2	0–10 V	± 10 V
2	×4	0–5 V	± 5 V
3	×5	0–4 V	± 4 V
4	×8	0–2.5 V	± 2.5 V
5	×10	0–2 V	± 2 V
6	×16	0–1.25 V	± 1.25 V
7	×20	0–1 V	± 1 V

reserved is reserved for future use. Set to 0.

RETURN VALUE

The status byte from the previous command. -1 means that device information indicates the A/D Converter Card is not connected to the master.

SEE ALSO

`rn_anaIn`, `rn_anaInVolts`, `rn_anaInDiff`, `rn_anaInmAmps`

```
int rn_anaIn(int handle, int channel, int *retdata,  
int sample, int reserved);
```

Reads the raw data value of an analog input channel. Set the **sample** parameter greater than one to average the readings.

This function provides the fastest A/D conversion rate.

PARAMETERS

handle is an address index to device information. Use **rn_device()** or **rn_find()** to establish the handle.

channel is the channel number (0 to 7) corresponding to AIN0–AIN7

retdata is a pointer to a raw data value of 0–2047 for 11-bit A/D conversions with a signed 12th bit

sample is x number of samples

1 = read current value of the given A/D converter channel

>1 = read given channel x times, and average the readings taken

reserved is reserved for future use. Set to 0.

RETURN VALUE

The status byte from the previous command and a return pointer to the raw input data. -1 means that device information indicates the A/D Converter Card is not connected to the master.

SEE ALSO

rn_anaInConfig, **rn_anaInVolts**, **rn_anaInmAmps**, **rn_anaInDiff**

```
int rn_anaInVolts(int handle, int channel,
                 float *retdata, int sample, int reserved);
```

Reads the state of an analog input channel. Set the **sample** parameter greater than one to average the readings.

PARAMETERS

handle is an address index to device information. Use `rn_device()` or `rn_find()` to establish the handle.

channel is the channel number (0 to 7) corresponding to AIN0–AIN7

retdata is a pointer to the voltage value (if there is a data overflow or an out-of-range error, the value will be set to -4096 as defined by the macro `ADOVERFLOW`)

sample is x number of samples

1 = read current value of the given A/D converter channel

>1 = read given channel x times, and average the readings taken

reserved is reserved for future use. Set to 0.

RETURN VALUE

The status byte from the previous command and a return pointer to the voltage input data. -1 means that device information indicates the A/D Converter Card is not connected to the master.

SEE ALSO

`rn_anaInConfig`, `rn_anaIn`, `rn_anaInmAmps`, `rn_anaInDiff`

```
int rn_anaInDiff(int handle, int channel,
float *retdata, int sample, int reserved);
```

Reads the state of an analog input channel. Set the **sample** parameter greater than one to average the readings.

PARAMETERS

handle is an address index to device information. Use `rn_device()` or `rn_find()` to establish the handle.

channel is the channel number (0, 2, 4, 6)

channel	DIFF
0	+AIN0 -AIN1
2	+AIN2 -AIN3
4	+AIN4 -AIN5
6	+AIN6 -AIN7

retdata is a pointer to the voltage value (if there is a data overflow or an out-of-range error, the value will be set to -4096 as defined by the macro `ADOVERFLOW`)

sample is x number of samples

1 = read current value of the given A/D converter channel

>1 = read given channel x times, and average the readings taken

reserved is reserved for future use. Set to 0.

RETURN VALUE

The status byte from the previous command and a return pointer to the voltage input data. -1 means that device information indicates the A/D Converter Card is not connected to the master.

SEE ALSO

`rn_anaInConfig`, `rn_anaIn`, `rn_anaInmAmps`, `rn_anaInVolts`

```
int rn_anaInmAmps(int handle, int channel,
                 float *retdata, int sample, int reserved);
```

Reads the state of a 4–20 mA analog input channel. Set the **sample** parameter greater than one to average the readings.

PARAMETERS

handle is an address index to device information. Use `rn_device()` or `rn_find()` to establish the handle.

channel is the channel number (0 to 7) corresponding to AIN0–AIN7

retdata is a pointer to the 4–20 mA value (if there is a data overflow or an out-of-range error, the value will be set to -4096 as defined by the macro `ADOVERFLOW`)

sample is x number of samples

1 = read current value of the given A/D converter channel

>1 = read given channel x times, and average the readings taken

reserved is reserved for future use. Set to 0.

RETURN VALUE

The status byte from the previous command and a return pointer to the 4–20 mA input data. -1 means that device information indicates the A/D Converter Card is not connected to the master.

SEE ALSO

`rn_anaInConfig`, `rn_anaIn`, `rn_anaInVolts`, `rn_anaInDiff`

```
int rn_anaInCalib(int channel, int opmode,
  int gaincode, int value1, float volts1,
  int value2, float volts2, rn_AinData *adata);
```

Calibrates the response of an analog input channel as a linear function using the two conversion points provided. Four values are calculated, and the results are sent later to the analog input device using the function `anaInWrCalib()`.

Each channel will have the following information:

- a linear constant or gain,
- a voltage offset.

NOTE: Typical calibration constants are loaded at the factory. This function should be used when you need more precise calibration or recalibration, or the calibration constants were corrupted in the device.

PARAMETERS

channel is the analog input channel number (0 to 7) corresponding to AIN0–AIN7

channel	SINGLE	DIFF	mAMP
0	+AIN0	+AIN0 -AIN1	+AIN0
1	+AIN1	—	+AIN1
2	+AIN2	+AIN2 -AIN3	+AIN2
3	+AIN3	—	+AIN3
4	+AIN4	+AIN4 -AIN5	+AIN4*
5	+AIN5	—	+AIN5*
6	+AIN6	+AIN6 -AIN7	+AIN6*
7	+AIN7	—	+AIN7*

* These channels need to be configured for current measurements as explained in Section 3.4.1.

opmode is the mode of operation for the specified channel:

- RNSINGLE**—single-ended input line
- RNDIFF**—differential input line
- RNmAMP**—4–20 mA input line

gaincode is the gain code of 0 to 7 (use a gain code of 4 for 4–20 mA operation)

Gain Code	Multiplier	Voltage Range	
		Single-Ended	Differential
0	×1	0–20 V	± 20 V
1	×2	0–10 V	± 10 V
2	×4	0–5 V	± 5 V
3	×5	0–4 V	± 4 V
4	×8	0–2.5 V	± 2.5 V
5	×10	0–2 V	± 2 V
6	×16	0–1.25 V	± 1.25 V
7	×20	0–1 V	± 1 V

value1 is the first raw data value read from the A/D converter channel

volts1 is the voltage corresponding to the first input value (minimum and maximum voltage with respect to the limits of the analog input)

value2 is the second raw data value read from the A/D converter channel

volts2 is the voltage corresponding to the second input value ((minimum and maximum voltage with respect to the limits of the analog input)

rn_AinData *adata is a pointer to the structure where the calibration constants, gain, and offset are written to after being calculated

RETURN VALUE

0, if successful.

-1 if not able to make calibration constants.

SEE ALSO

`rn_anaInWrCalib`

```
int rn_anaInWrCalib(int handle, int channel,
    int opmode, int gaincode, rn_AinData adata,
    int reserved);
```

Writes the calibration constants, gain, and offset previously calculated by `rn_anaInCalib()` into the analog device flash memory. A hardware reset (`rn_reset()`) and a read reset register (`rn_rst_status()`) must be issued after this function is called.

NOTE: Typical calibration constants are loaded at the factory. This function should be used when you need more precise calibration or recalibration, or the calibration constants were corrupted in the device.

PARAMETERS

handle is an address index to device information. Use `rn_device()` or `rn_find()` to establish the handle.

channel is the analog input channel number (0 to 7) corresponding to AIN0–AIN7

channel	SINGLE	DIFF	mAMP
0	+AIN0	+AIN0 -AIN1	+AIN0
1	+AIN1	—	+AIN1
2	+AIN2	+AIN2 -AIN3	+AIN2
3	+AIN3	—	+AIN3
4	+AIN4	+AIN4 -AIN5	+AIN4*
5	+AIN5	—	+AIN5*
6	+AIN6	+AIN6 -AIN7	+AIN6*
7	+AIN7	—	+AIN7*

* These channels need to be configured for current measurements as explained in Section 3.4.1.

opmode is the mode of operation for the specified channel:

RNSINGLE—single-ended input line

RNDIFF—differential input line

RNmAMP—4–20 mA input line

gaincode is the gain code of 0 to 7 (use a gain code of 4 for 4–20 mA operation)

Gain Code	Multiplier	Voltage Range	
		Single-Ended	Differential
0	×1	0–20 V	± 20 V
1	×2	0–10 V	± 10 V
2	×4	0–5 V	± 5 V
3	×5	0–4 V	± 4 V
4	×8	0–2.5 V	± 2.5 V
5	×10	0–2 V	± 2 V
6	×16	0–1.25 V	± 1.25 V
7	×20	0–1 V	± 1 V

rn_AinData adata is a pointer to the structure where the calibration constants, gain, and offset are written to after being calculated

reserved is reserved for future use. Set to 0.

RETURN VALUE

The status byte from the previous command and a return pointer to the raw input data. -1 means that device information indicates the A/D Converter Card is not connected to the master.

SEE ALSO

`rn_anaInRdCalib`, `rn_anaInCalib`

```
int rn_anaInRdCalib(int handle, int channel,
    int opmode, int gaincode, rn_AinData *adata,
    int reserved);
```

Reads the calibration constants, gain, and offset from a device with analog inputs.

PARAMETERS

handle is an address index to device information. Use `rn_device()` or `rn_find()` to establish the handle.

channel is the analog input channel number (0 to 7) corresponding to AIN0–AIN7

channel	SINGLE	DIFF	mAMP
0	+AIN0	+AIN0 -AIN1	+AIN0
1	+AIN1	—	+AIN1
2	+AIN2	+AIN2 -AIN3	+AIN2
3	+AIN3	—	+AIN3
4	+AIN4	+AIN4 -AIN5	+AIN4*
5	+AIN5	—	+AIN5*
6	+AIN6	+AIN6 -AIN7	+AIN6*
7	+AIN7	—	+AIN7*

* These channels need to be configured for current measurements as explained in Section 3.4.1.

opmode is the mode of operation for the specified channel:

RNSINGLE—single-ended input line

RNDIFF—differential input line

RNmAMP—4–20 mA input line

gaincode is the gain code of 0 to 7 (use a gain code of 4 for 4–20 mA operation)

Gain Code	Multiplier	Voltage Range	
		Single-Ended	Differential
0	×1	0–20 V	± 20 V
1	×2	0–10 V	± 10 V
2	×4	0–5 V	± 5 V
3	×5	0–4 V	± 4 V
4	×8	0–2.5 V	± 2.5 V
5	×10	0–2 V	± 2 V
6	×16	0–1.25 V	± 1.25 V
7	×20	0–1 V	± 1 V

rn_AinData *adata is a pointer to the structure where the calibration constants, gain, and offset are written to after being calculated

reserved is reserved for future use. Set to 0.

RETURN VALUE

The status byte from the previous command and a return pointer to the raw input data. -1 means that device information indicates the A/D Converter Card is not connected to the master.

SEE ALSO

`rn_anaInWrCalib`, `rn_anaInCalib`

3.5.4 Status Byte

Section 1.3.5 provides information on the status bytes returned by various function calls.

3.6 Specifications

3.6.1 Electrical and Mechanical Specifications

Figure 24 shows the mechanical dimensions for the A/D Converter Card.

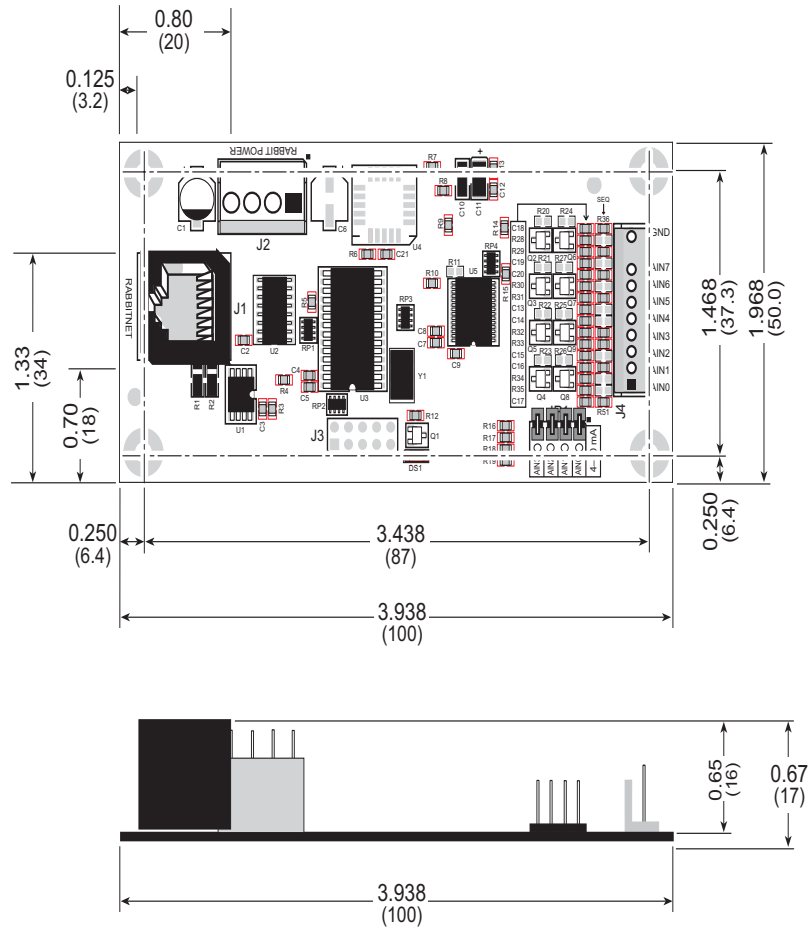

Figure 24. A/D Converter Card Dimensions

NOTE: All diagram and graphic measurements are in inches followed by millimeters enclosed in parentheses.

Table 7 lists the electrical, mechanical, and environmental specifications for the A/D Converter Card.

Table 7. A/D Converter Card Specifications

Feature	Specification
Analog Inputs	8 single-ended 11-bit or 4 differential 12-bit analog inputs, 1 M Ω input impedance, 2.5 ksamples/s sampling rate, all 8 channels can be configured as 11-bit 4–20 mA analog inputs <ul style="list-style-type: none"> • software-controlled ranges: 0–1 V, 2 V, 5 V, 10 V, 20 V DC (single-ended) or ± 1 V, ± 2 V, ± 5 V, ± 10 V, ± 20 V DC (differential)
RabbitNet™ Serial Port	RS-422 SPI, 1 Mbits/s
Power	V _{cc} : +5 V DC, 100 mA
Temperature	-40°C to +70°C
Humidity	5% to 95%, noncondensing
Connectors	Friction-lock connectors: one polarized 9-position terminals with 0.1" pitch one 4-position terminal with 0.156" pitch One RJ-45 RabbitNet™ jack
Board Size	1.97" × 3.94" × 0.67" (50 mm × 100 mm × 17 mm)

3.6.2 Physical Mounting

Figure 25 shows position information to assist with interfacing other boards with the A/D Converter Card.

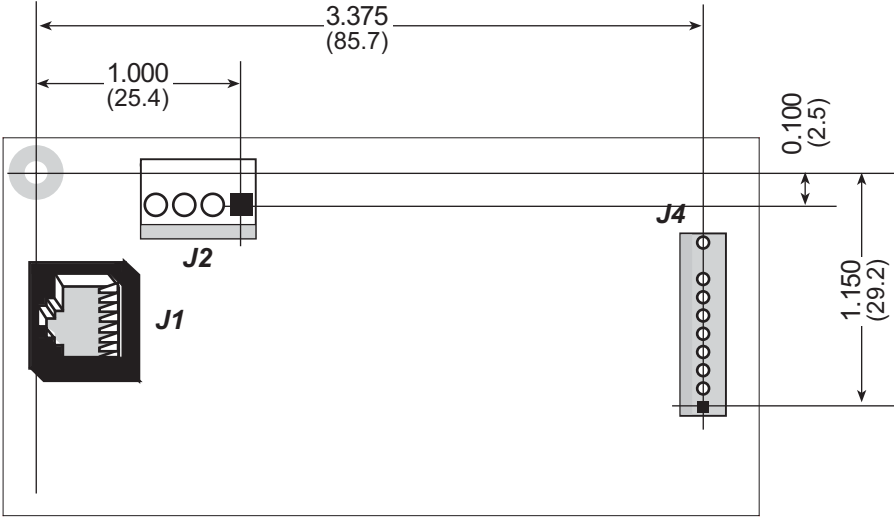

Figure 25. User Board Footprint for A/D Converter Card

3.7 Jumper Configurations

Figure 26 shows the header and jumper locations used to configure the various A/D Converter Card options.

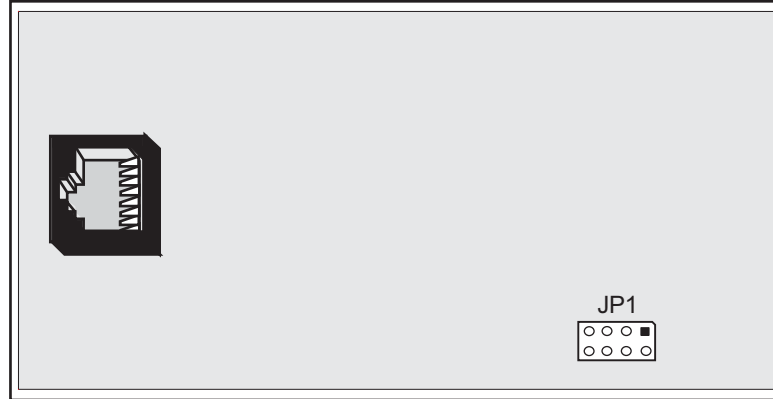

Figure 26. Location of A/D Converter Card Configurable Positions

Table 8 lists the configuration options. Standard pluggable jumpers are used.

Table 8. A/D Converter Card Jumper Configurations

Header	Description	Pins Connected		Factory Default
JP1	Analog Voltage/4–20 mA Options	1–2	Connect for 4–20 mA option on AIN0	n.c.
		3–4	Connect for 4–20 mA option on AIN1	n.c.
		5–6	Connect for 4–20 mA option on AIN2	n.c.
		7–8	Connect for 4–20 mA option on AIN3	n.c.



4. D/A CONVERTER CARD

Chapter 4 describes the features and the use of the D/A Converter Card, one of the peripheral cards designed for use with the RabbitNet expansion ports on selected Rabbit Semiconductor single-board computers, operator interfaces, and RabbitCore Prototyping Boards.

Figure 27 shows a conceptual view of the D/A Converter Card connected to a master.

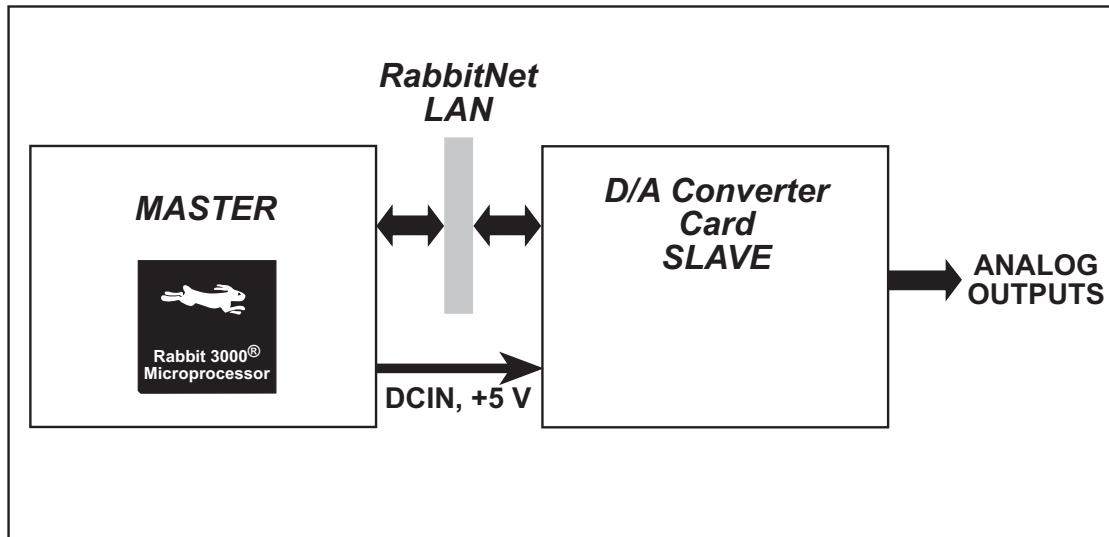

Figure 27. A/D Converter Card (Slave) Connected to Master

NOTE: The OP7200 master and the RabbitCore Prototyping Boards do *not* supply any power to the slave.

4.1 Features

- 8 channels of 12-bit analog outputs
- 2 channels are software-configurable for output voltage ranges of 0–2.5 V, 0–5 V, 0–10 V, or 0–20 V, remaining 6 channels have software-configurable output voltage ranges of 0–10 V or 0–20 V
- 2.5 kHz update rate
- output impedance 8 Ω
- can be mounted in standard 100 mm DIN rail trays sold by other suppliers
- interfaces with master through RabbitNet™ serial protocol at 1 Megabit per second using standard Ethernet cable up to 10 m (33 ft) long

4.1.1 Software

The D/A Converter Card is a slave; the master to which it is connected is programmed using version 8.01 or later of Rabbit Semiconductor's Dynamic C. If you are using a BL2500 or an OP7200 as your master with an earlier version of Dynamic C, Rabbit Semiconductor recommends that you upgrade your Dynamic C installation. Contact your authorized Rabbit Semiconductor distributor or your Rabbit Semiconductor Sales Representative for more information on Dynamic C upgrades.

4.2 Connections

Use a straight-through CAT 5/6 Ethernet cable to connect the D/A Converter Card's RJ-45 RabbitNet jack to a RabbitNet port on the master. You may use either port if you are connecting to a master such as the BL2500 that has more than one RabbitNet port.

NOTE: The RJ-45 *RabbitNet* jacks are serial I/O ports for use with a master and a network of peripheral boards. The *RabbitNet* jacks do *not* support Ethernet connections.

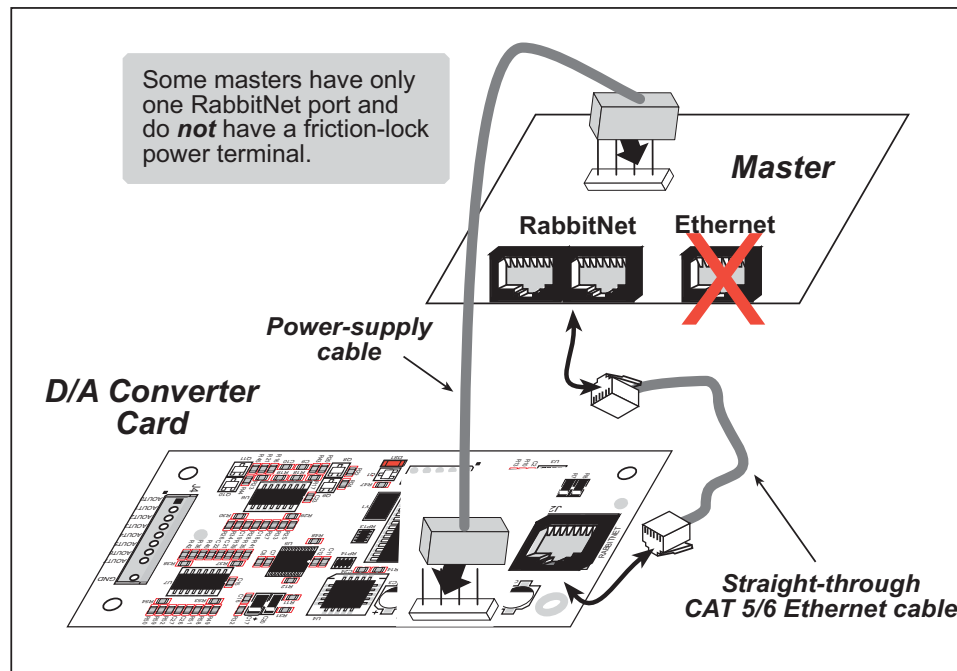

Figure 28. Connect D/A Converter Card to Master

You will also have to provide two separate DC power supplies to your D/A Converter Card: +5 V and a DCIN of 9–32 V. These power supplies are connected via the polarized friction-lock terminal at header J1. You may assemble a suitable cable using the friction-lock connectors from the Connectivity Kit described in Section 1.1.3. If you are using a BL2500 or BL2600 as your master, you may draw this power from the BL2500 or BL2600 as shown in Figure 28.

When selecting DCIN, note that DCIN must be at least 3 V more than the voltage of the D/A converter output. For example, if AOUT0 is configured for 0–20 V, DCIN must be at least 23 V, otherwise the maximum D/A converter output will be $DCIN - 3$ V.

NOTE: Even if you are not drawing power from a master, you will need to connect the D/A Converter Card ground to the ground on your master. The GND pin on header J3 should be used.

4.2.1 Power Supply

Figure 29 illustrates the assembled friction-lock connector wiring diagram for the power supplies used to supply power to the D/A Converter Card.

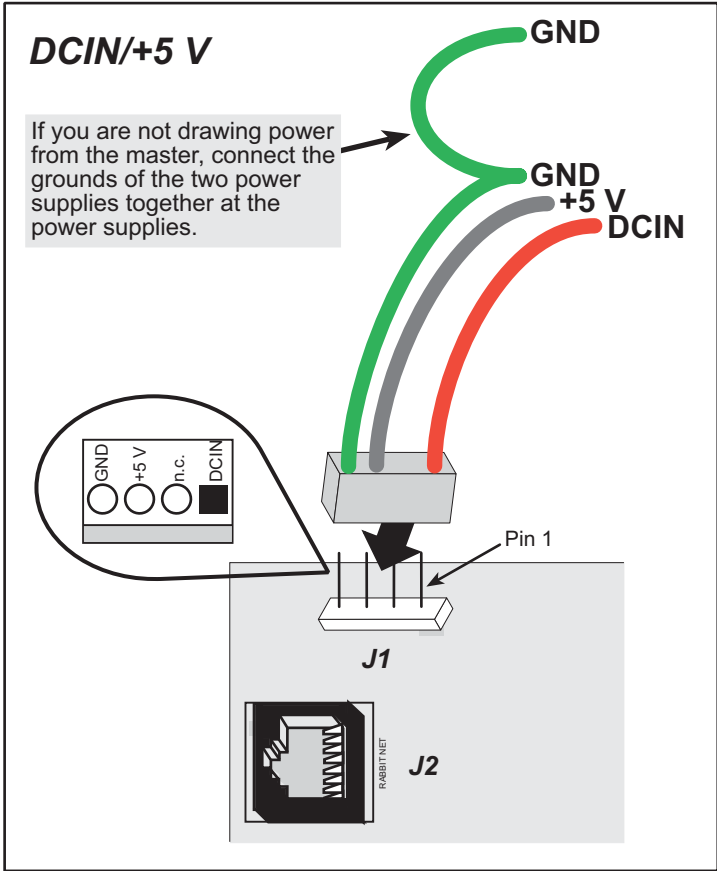

Figure 29. Power-Supply Connections

RN1300

4.3 Pinout

The D/A Converter Card pinouts are shown in Figure 30.

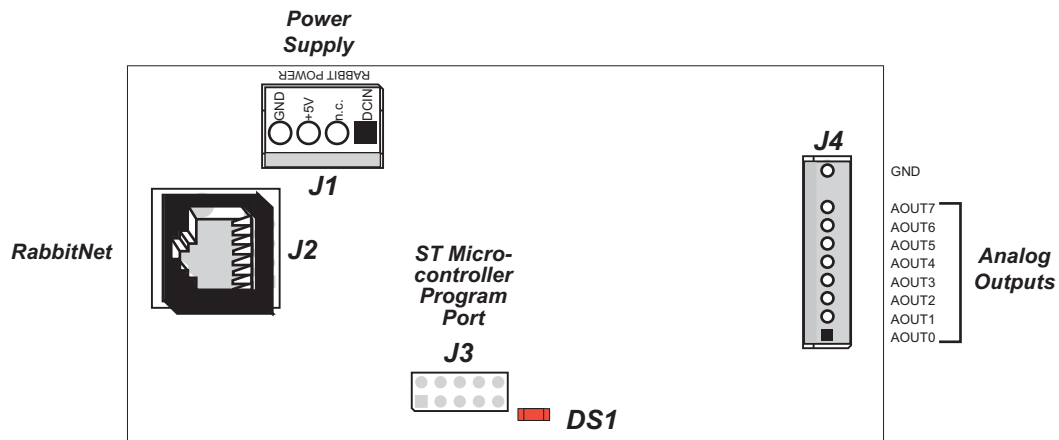

Figure 30. D/A Converter Card Pinouts

4.3.1 Headers

D/A Converter Cards are equipped with one polarized 1 × 9 friction-lock terminals at J4, a 1 × 4 friction-lock terminal at J1 (DCIN and +5 V power supplies), and an RJ-45 RabbitNet jack.

No header is installed at J3, which is used to program the D/A Converter Card at the factory.

4.3.2 Indicator LED

An indicator LED (DS1) located near the header J3 location turns on when the D/A Converter Card is powered up, then goes off when the D/A Converter Card has completed its initialization process and is running. The LED will be on while the D/A Converter Card is receiving a transmission from the master.

4.4 D/A Converter Outputs

Figure 31 shows the D/A converter outputs.

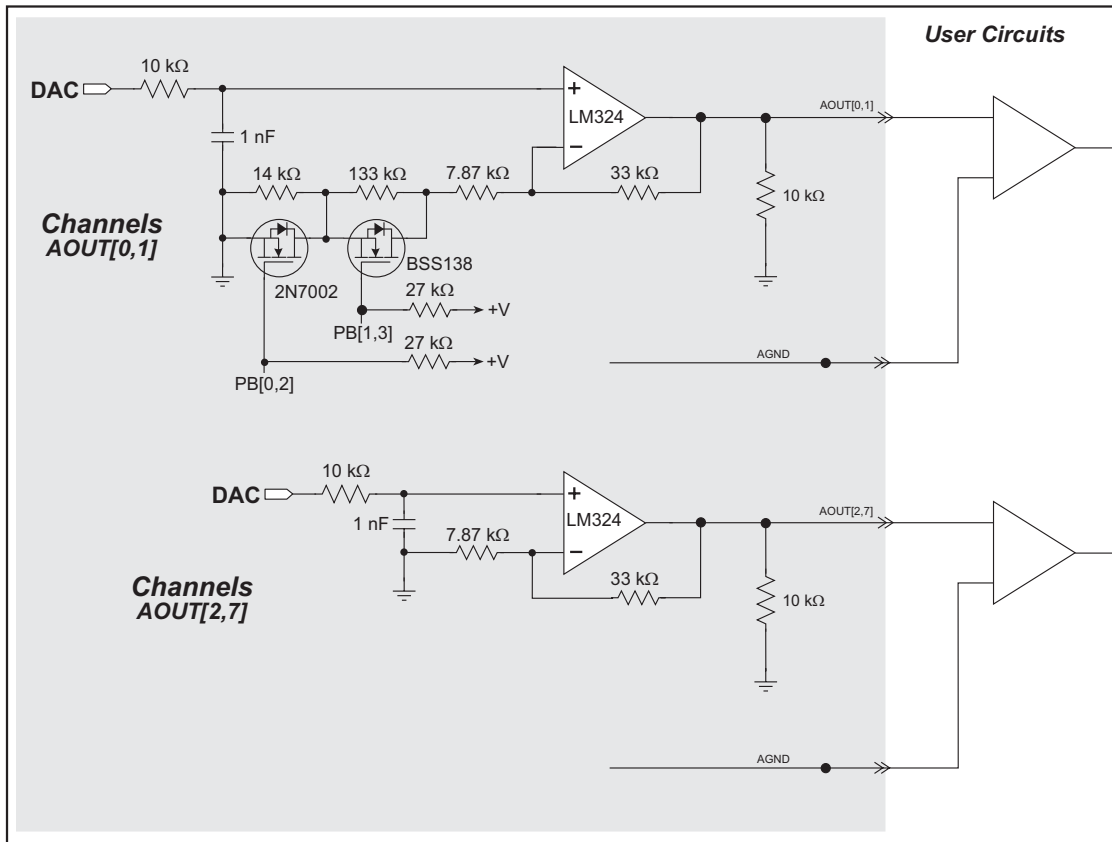

Figure 31. D/A Converter Outputs

The D/A converter outputs are buffered and scaled to provide outputs that are software-configurable for voltage ranges of 0–10 V and 0–20 V. Channels AOUT0 and AOUT1 can also be configured in software to provide output ranges of 0–5 V.

NOTE: The D/A converter output voltage depends on the original power-supply voltage, DCIN, which must be at least 3 V more than the voltage of the D/A converter output. For example, if AOUT0 is configured for 0–20 V, DCIN must be at least 23 V, otherwise the maximum D/A converter output will be DCIN – 3 V.

While each D/A converter channel can output up to 10 mA, the total power dissipation by the LM324 op-amp at any instant must be kept below 400 mW, or $(400 \text{ mW}) / (\text{DCIN} \times 4)$ mA per channel.

The D/A Converter Card outputs can be updated asynchronously as raw data are processed and written, or they may be updated simultaneously by executing the `rn_anaOutStrobe()` function call with the `opmode` parameter in the `rn_anaOutConfig()` function call set for synchronous operation. Further details are provided in Section 4.5.3, “D/A Converter Card Function Calls.”

4.4.1 Calibration

The D/A converter outputs are factory-calibrated for the 0–10 V output range, and typical calibration constants are stored in the flash memory for the other voltage ranges. You may recalibrate the D/A converter outputs at a later time using the `rn_anaOutCalib()` software function described in Section 4.5.3, “D/A Converter Card Function Calls.”

The calibration constants are stored in flash memory in a table form. When you recalibrate your D/A Converter Card, only the calibration constants related to the voltage range you recalibrated will be overwritten.

The `DAC_CAL.C` sample program illustrates how to perform the calibration and save the calibration data. The sample program is found in the in the `SAMPLES\RABBITNET\RN1300` directory. See Section 4.5.2, “Sample Programs,” for more information on sample programs and how to use them.

4.5 Software

This section provides the libraries, function calls, and sample programs related to the D/A Converter Card.

4.5.1 Dynamic C Libraries

In addition to the library associated with the master single-board computer such as the BL2500 or OP7200, one other library is needed to provide function calls for the D/A Converter Card.

- **RNET_AOUT.LIB**—provides functions unique to the analog outputs on the D/A Converter Card. Function calls for this library are discussed in this chapter.

Functions relevant to RabbitNet peripheral cards in general are described in Section 1.3.4. Other functions applicable to all devices based on Rabbit microprocessors are described in the *Dynamic C Function Reference User's Manual*.

4.5.2 Sample Programs

Sample programs are provided in the Dynamic C **SAMPLES** folder.

The various folders contain specific sample programs that illustrate the use of the corresponding Dynamic C libraries. For example, the sample program **PONG.C** demonstrates the output to the **STDIO** window.

To run a sample program, open it with the **File** menu (if it is not still open), then compile and run it by pressing **F9** or by selecting **Run** in the **Run** menu. The RabbitNet peripheral card must be connected to a master such as the BL2500 with its Demonstration Board connected as explained in the *Coyote (BL2500) User's Manual* or other user's manual. The BL2500 or other master must be in Program Mode, and must be connected via the programming cable to a PC.

The **SAMPLES\RABBITNET\RN1300** subdirectory contains the following sample programs. When running these sample programs, the D/A Converter Card may be connected to either RabbitNet port on a master such as the BL2500 that has two RabbitNet ports. The sample program will use **rn_find()** and the product RN1300 as the search criteria to first find any D/A Converter Cards connected to the master. The first D/A Converter Card found will run the sample program.

- **DAC_ASYNC.C**—This sample program outputs a voltage that can be read with a voltmeter. The output voltage is calculated using the calibration constants located on the D/A Converter Card EEPROM (simulated in flash memory).

The D/A Converter Card is set up for the asynchronous mode of operation, which updates a D/A converter output at the time it is being accessed via the **anaOutVolts()** or **anaOut()** functions. (i.e., the **anaOutStrobe()** function is not used to update the D/A converter outputs).

The sample program **DAC_SYNC.C** illustrates the synchronous mode of operation.

Before you run this sample program, make sure that the DCIN for the D/A Converter Card is at least 3 V more than the maximum voltage of the D/A converter output voltage range you

will be selecting. Connect a voltmeter to the output channel (DAC0–DAC7) you are going to be using, then compile and run this program. You will be prompted with additional instructions via the Dynamic C **STDIO** window during the execution of this sample program.

NOTE: This sample program must be compiled to flash.

- **DAC_SYNC.C**—This sample program outputs a voltage that can be read with a voltmeter. The output voltage is calculated using the calibration constants located on the D/A Converter Card EEPROM (simulated in flash memory).

The D/A Converter Card is set up for the synchronous mode of operation, which updates all D/A converter outputs at the same time when the `anaOutStrobe()` function executes. The outputs are all updated with values previously written using the `anaOutVolts()` and/or `anaOut()` functions.

Before you run this sample program, make sure that the DCIN for the D/A Converter Card is at least 3 V more than the maximum voltage of the D/A converter output voltage range you will be selecting. Connect a voltmeter to the output channel (DAC0–DAC7) you are going to be using, then compile and run this program. You will be prompted with additional instructions via the Dynamic C **STDIO** window during the execution of this sample program.

NOTE: This sample program must be compiled to flash.

- **DAC_CAL.C**—This program demonstrates how to recalibrate a D/A converter channel using two known voltages, and defines the two coefficients, gain, and offset, that will be rewritten into the D/A Converter Card's EEPROM (simulated in flash memory).

This program will first look for a device using `rn_find()` and the product RN1300 as the search criteria, and will use the first D/A Converter Card found.

Before you run this sample program, make sure that the DCIN for the D/A Converter Card is at least 3 V more than the maximum voltage of the D/A converter output voltage range you will be selecting. Connect a voltmeter to the output channel (DAC0–DAC7) you are going to be using, then compile and run this program. You will be prompted with additional instructions via the Dynamic C **STDIO** window during the execution of this sample program.

NOTE: The calibration constants set at the factory will be overwritten when you run this sample program.

- **DAC_READ_CALDATA.C**—Dumps the calibration data for all the D/A converter channels. The calibration gain factor, offset values, and mode of operation will be displayed for each channel via the Dynamic C **STDIO** window.

4.5.3 D/A Converter Card Function Calls

```
int rn_anaOutConfig(int handle, char config,  
int opmode, int reserved);
```

Configures the D/A Converter Card to the desired voltage range. Once the D/A Converter Card has been configured, use `rn_anaOut()`, `rn_anaOutVolts()`, and `rn_anaOutStrobe()` to control the D/A Converter Card outputs.

PARAMETERS

`handle` is an address index to device information. Use `rn_device()` or `rn_find()` to establish the handle.

`config` is a configuration code used to set the voltage ranges for the D/A Converter Card channels. Make sure that the DCIN for the D/A Converter Card is at least 3 V more than the maximum voltage of the D/A converter output voltage range you will be selecting.

Configuration Code	Voltage Ranges	
	Channels 0–1	Channels 2–7
0	0–2.5 V	0–10 V
1	0–5 V	0–10 V
2*	0–10 V	0–10 V
3	0–5 V	0–20 V
4	0–10 V	0–20 V
5	0–20 V	0–20 V

* Default setting after reset

`opmode` is the mode of operation

0 = asynchronous—outputs are updated at the time raw data are written (default mode after reset)

1 = synchronous—outputs are updated when `rn_anaOutStrobe` is executed

`reserved` is reserved for future use. Set to 0.

RETURN VALUE

The status byte from the previous command. -1 means that device information indicates the D/A Converter Card is not connected to the master.

SEE ALSO

`rn_anaOut`, `rn_anaOutVolts`, `rn_anaOutStrobe`

```
int rn_anaOut(int handle, int channel, int rawdata,
int reserved);
```

Sets an analog output channel to a voltage that corresponds to the raw data value.

If the D/A Converter Card is set to the asynchronous mode of operation (the default mode), the output channel will be updated at the time the raw data are being written.

If the D/A Converter Card is set to the synchronous mode of operation, all the D/A converter outputs will be updated with the raw data values previously written (or default value of zero) when the **rn_anaOutStrobe** function is executed.

The voltage range of the D/A converter outputs will be 0–10 V (default) or one of the other voltage range options previously set with the **rn_anaInConfig()** function. Make sure that the DCIN for the D/A Converter Card is at least 3 V more than the maximum voltage of the D/A converter output voltage range you will be selecting.

Configuration Code	Voltage Ranges	
	Channels 0–1	Channels 2–7
0	0–2.5 V	0–10 V
1	0–5 V	0–10 V
2*	0–10 V	0–10 V
3	0–5 V	0–20 V
4	0–10 V	0–20 V
5	0–20 V	0–20 V

* Default setting after reset

PARAMETERS

handle is an address index to device information. Use **rn_device()** or **rn_find()** to establish the handle.

channel is the channel number (0 to 7) corresponding to AOUT0–AOUT7

rawdata is the raw-data value (2 bytes)

reserved is reserved for future use. Set to 0.

RETURN VALUE

The status byte from the previous command and a return pointer to the raw input data. -1 means that device information indicates the D/A Converter Card is not connected to the master.

SEE ALSO

rn_anaOutConfig, **rn_anaOutVolts**, **rn_anaOutStrobe**

```
int rn_anaOutVolts(int handle, int channel,
float voltage, struct rn_dacCalTable *tables,
int reserved);
```

Sets an analog output channel to a voltage using previously set calibration constants to obtain the desired voltage. Remember to run the `rn_anaOutRdCalib()` function before executing this function so the calibration table will contain valid data. Here's an example.

```
for(channel=0; channel < 8; channel++) {
    rn_anaOutRdCalib(device0, channel, &DacCalTable1, 0);
}
```

If the D/A Converter Card is set to the asynchronous mode of operation (the default mode), the output channel will be updated at the time the raw data are being written.

If the D/A Converter Card is set to the synchronous mode of operation, all the D/A converter outputs will be updated with the raw data values previously written (or default value of zero) when the `rn_anaOutStrobe` function is executed.

The voltage range of the D/A converter outputs will be 0–10 V (default) or one of the other voltage range options previously set with the `rn_anaInConfig()` function. Make sure that the DCIN for the D/A Converter Card is at least 3 V more than the maximum voltage of the D/A converter output voltage range you will be selecting.

Configuration Code	Voltage Ranges	
	Channels 0–1	Channels 2–7
0	0–2.5 V	0–10 V
1	0–5 V	0–10 V
2*	0–10 V	0–10 V
3	0–5 V	0–20 V
4	0–10 V	0–20 V
5	0–20 V	0–20 V

* Default setting after reset

PARAMETERS

handle is an address index to device information. Use `rn_device()` or `rn_find()` to establish the handle.

channel is the channel number (0 to 7) corresponding to AOUT0–AOUT7

voltage is the desired output voltage, which must be less than or equal to the maximum voltage in the voltage range specified by the `rn_anaInConfig()` function

rn_dacCalTable *tables is a pointer to a table structure that contains the calibration constants for channels 0–7 for the selected mode

reserved is reserved for future use. Set to 0.

RETURN VALUE

The status byte from the previous command and a return pointer to the voltage input data. -1 means that device information indicates the D/A Converter Card is not connected to the master.

SEE ALSO

`rn_anaOutConfig`, `rn_anaOut`, `rn_anaOutStrobe`

```
int rn_anaOutStrobe(int handle, int reserved);
```

Strobes the D/A Converter Card to update all the D/A converter outputs with the raw data values previously written (or a default value of zero).

NOTE: This function is only valid if the D/A Converter Card is set to the synchronous mode of operation using the **rn_anaOutConfig** function call.

PARAMETERS

handle is an address index to device information. Use **rn_device()** or **rn_find()** to establish the handle.

reserved is reserved for future use. Set to 0.

RETURN VALUE

The status byte from the previous command and a return pointer to the voltage input data. -1 means that device information indicates the D/A Converter Card is not connected to the master.

SEE ALSO

rn_anaOutConfig, rn_anaOut, rn_anaOutVolts

```
int rn_anaOutCalib(int channel, int value1,
    float volts1, int value2, float volts2,
    DacCal *table, int reserved);
```

Calibrates the response of the desired analog output channel as a linear function using the two conversion points provided. Values are calculated and the results are sent to the analog output device using the function `anaOutWrCalib()`.

Each channel will have the following information:

- linear constant or gain
- voltage offset

NOTE: Typical calibration constants are loaded at the factory. This function should be used when you need more precise calibration or recalibration, or the calibration constants in the device were corrupted.

PARAMETERS

`channel` is the channel number (0 to 7) corresponding to AOUT0–AOUT7

`value1` is the first raw analog output value (0–4095)

`volts1` is the voltage corresponding to the first output value

`value2` is the second raw analog output value (0–4095)

`volts2` is the voltage corresponding to the second output value

`DacCal *table` is a pointer to a table structure that contains the calibration constants

`reserved` is reserved for future use. Set to 0.

RETURN VALUE

0, if successful.

-1 if not able to make calibration constants.

SEE ALSO

`rn_anaOutWrCalib`, `rn_anaOutRdCalib`

```
int rn_anaOutWrCalib(int handle, int channel,  
    DacCal *table, int reserved);
```

Writes the calibration constants, gain, and offset previously calculated by `rn_anaOutCalib()` into the device flash memory.

NOTE: Typical calibration constants are loaded at the factory. This function should be used when you need more precise calibration or recalibration, or the calibration constants in the device were corrupted.

PARAMETERS

handle is an address index to device information. Use `rn_device()` or `rn_find()` to establish the handle.

channel is the channel number (0 to 7) corresponding to AOUT0–AOUT7

DacCal *table is a pointer to a table structure that contains the calibration constants

reserved is reserved for future use. Set to 0.

RETURN VALUE

The status byte from the previous command and a return pointer to the raw input data. -1 means that device information indicates the D/A Converter Card is not connected to the master.

SEE ALSO

`rn_anaOutRdCalib`, `rn_anaOutCalib`

```
int rn_anaOutRdCalib(int handle, int channel,
    DacCal *table, int reserved);
```

Reads the calibration constants, gain, and offset into a calibration descriptor table `rn_dacCalTable`.

PARAMETERS

`handle` is an address index to device information. Use `rn_device()` or `rn_find()` to establish the handle.

`channel` is the channel number (0 to 7) corresponding to AOUT0–AOUT7

`DacCal *table` is a pointer to a table structure that contains the calibration constants

`reserved` is reserved for future use. Set to 0.

RETURN VALUE

The status byte from the previous command and a return pointer to the raw input data. -1 means that device information indicates the D/A Converter Card is not connected to the master.

SEE ALSO

`rn_anaOutWrCalib`, `rn_anaOutCalib`

4.5.4 Status Byte

Section 1.3.5 provides information on the status bytes returned by various function calls.

4.6 Specifications

4.6.1 Electrical and Mechanical Specifications

Figure 32 shows the mechanical dimensions for the D/A Converter Card.

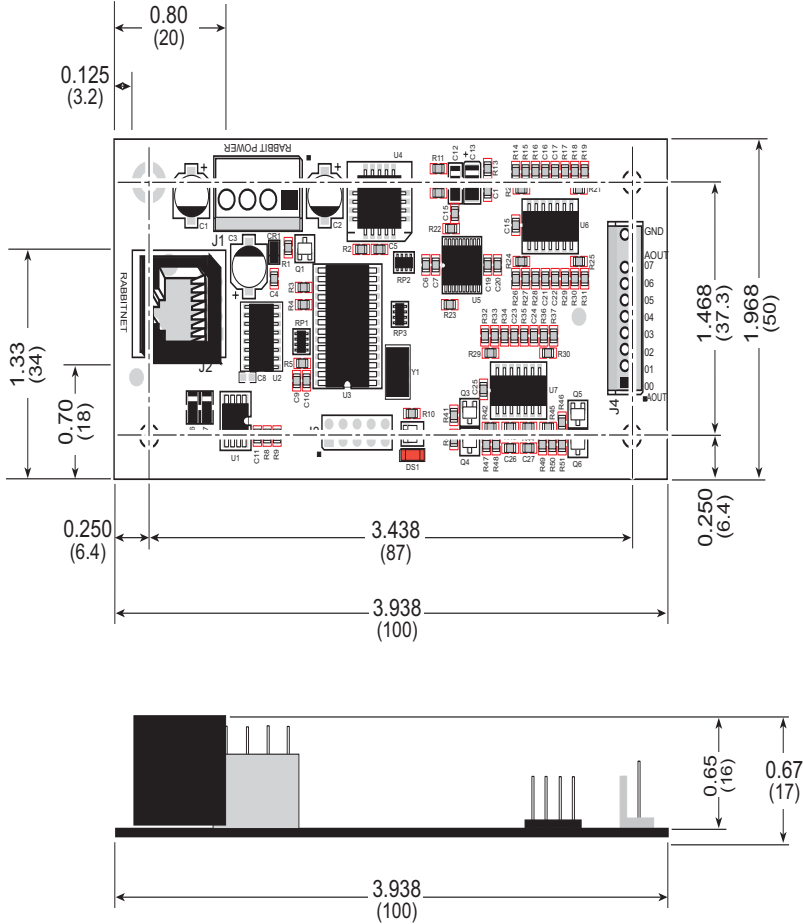

Figure 32. D/A Converter Card Dimensions

NOTE: All diagram and graphic measurements are in inches followed by millimeters enclosed in parentheses.

Table 9 lists the electrical, mechanical, and environmental specifications for the D/A Converter Card.

Table 9. D/A Converter Card Specifications

Feature	Specification
Analog Outputs	8 channels of 12-bit analog outputs, 8 Ω output impedance, 2.5 kHz update rate <ul style="list-style-type: none"> • software-controlled output-voltage ranges: 0–2.5 V, 0–5 V, 0–10 V, 0–20 V DC (channels AOUT0–AOUT1) 0–10 V, 0–20 V DC (channels AOUT2–AOUT7)
RabbitNet™ Serial Port	RS-422 SPI, 1 Mbits/s
Power	Vcc: +5 V DC, 20 mA DCIN: 9–32 V, 100 mA
Temperature	-40°C to +85°C
Humidity	5% to 95%, noncondensing
Connectors	Friction-lock connectors: one polarized 9-position terminals with 0.1" pitch one 4-position terminal with 0.156" pitch One RJ-45 RabbitNet™ jack
Board Size	1.97" × 3.94" × 0.67" (50 mm × 100 mm × 17 mm)

4.6.2 Physical Mounting

Figure 33 shows position information to assist with interfacing other boards with the D/A Converter Card.

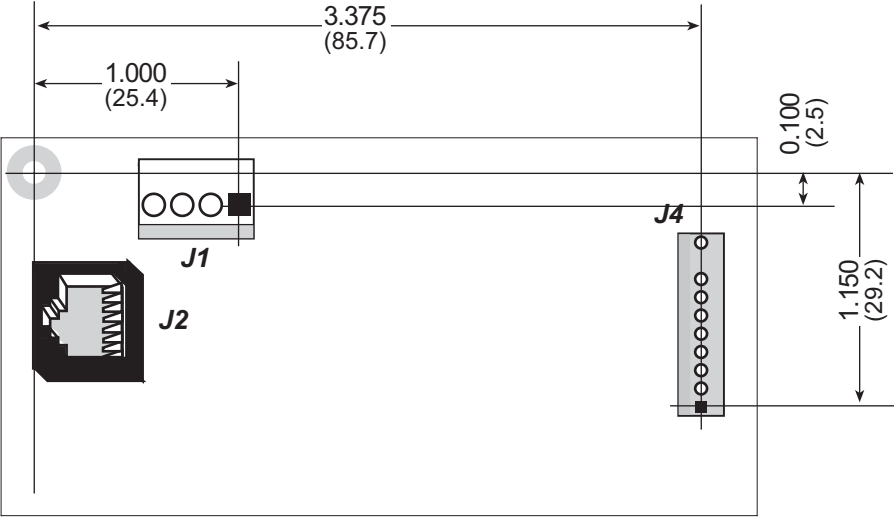

Figure 33. User Board Footprint for D/A Converter Card

RN1300

5. RELAY CARD

Chapter 5 describes the features and the use of the Relay Card, one of the peripheral cards designed for use with the RabbitNet expansion ports on selected Rabbit Semiconductor single-board computers, operator interfaces, and RabbitCore Prototyping Boards.

Figure 34 shows a conceptual view of the Relay Card connected to a master.

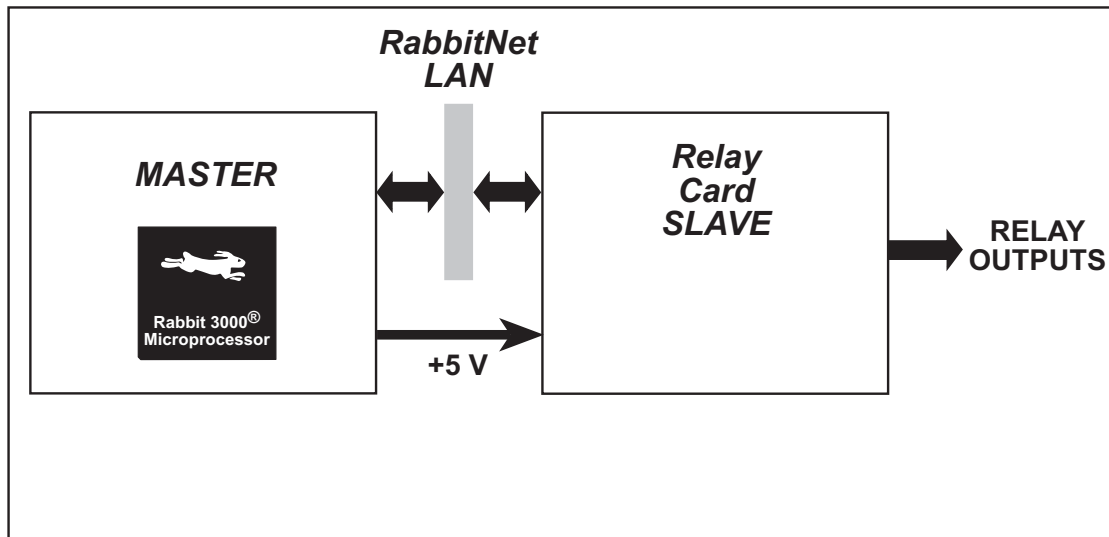

Figure 34. Relay Card (Slave) Connected to Master

NOTE: The OP7200 master and the RabbitCore Prototyping Boards do *not* supply any power to the slave.

5.1 Features

- 6 SPDT relays rated at 250 V AC, 1200 V·A (30 V DC up to 240 W) with built-in snubbers
- can be mounted in standard 100 mm DIN rail trays sold by other suppliers
- interfaces with master through RabbitNet™ serial protocol at 1 Megabit per second using standard Ethernet cable, can be up to 10 m (33 ft) away from master

5.1.1 Software

The Relay Card is a slave; the master to which it is connected is programmed using version 8.01 or later of Rabbit Semiconductor's Dynamic C. If you are using a BL2500 or an OP7200 as your master with an earlier version of Dynamic C, Rabbit Semiconductor recommends that you upgrade your Dynamic C installation. Contact your authorized Rabbit Semiconductor distributor or your Rabbit Semiconductor Sales Representative for more information on Dynamic C upgrades.

5.2 Connections

Use a straight-through CAT 5/6 Ethernet cable to connect the Relay Card's RJ-45 RabbitNet jack to a RabbitNet port on the master. You may use either port if you are connecting to a master such as the BL2500 that has more than one RabbitNet port.

NOTE: The RJ-45 *RabbitNet* jacks are serial I/O ports for use with a master and a network of peripheral cards. The *RabbitNet* jacks do not support Ethernet connections.

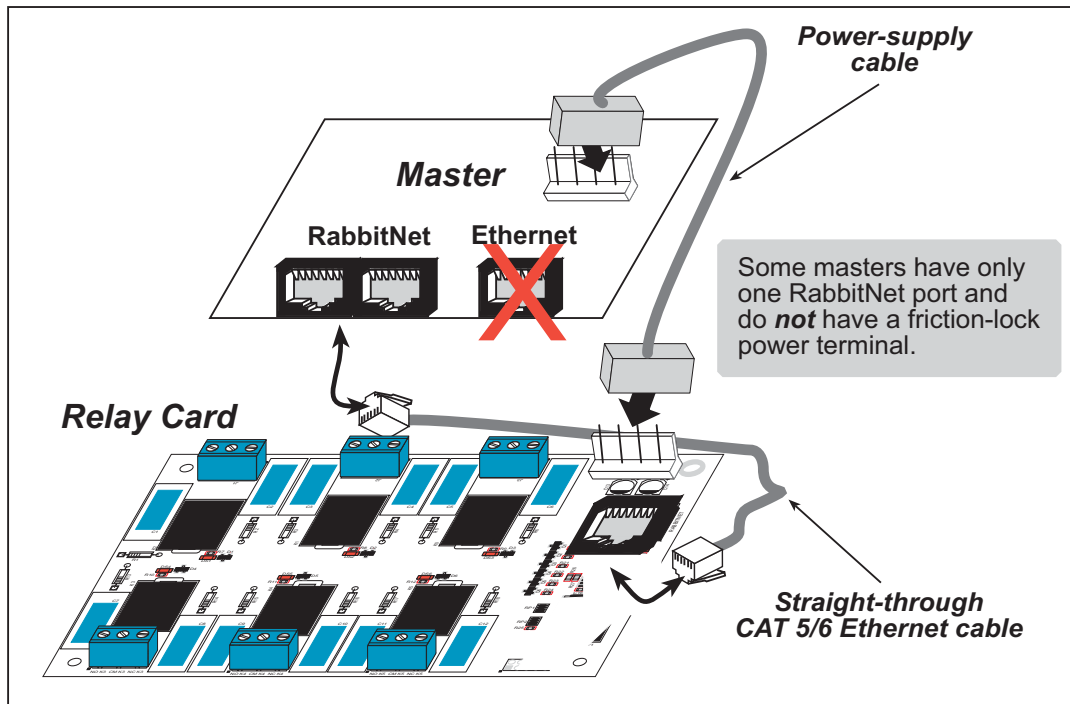

Figure 35. Connect Relay Card to Master

You will also have to provide a separate +5 V DC power supply to your Relay Card. This power supply is connected via the polarized friction-lock terminal at header J7. You may assemble a suitable cable using the friction-lock connectors from the Connectivity Kit described in Section 1.1.3. If you are using a BL2500 as your master, you may draw this power from the BL2500 as shown in Figure 35. See Section 5.2.1 for detailed wiring diagrams.

At the present time, the number of peripheral cards you can use with one master is limited by the number of RabbitNet ports on the master.

5.2.1 Power Supply

Figure 36 illustrates the assembled friction-lock connector wiring diagram for the power supplies used to supply power to the Relay Card.

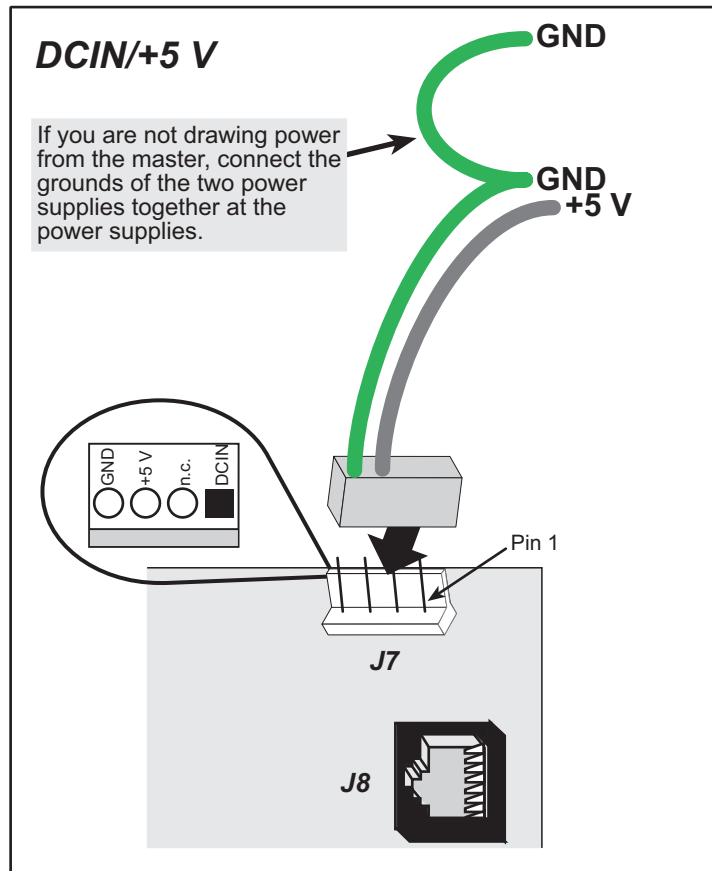

Figure 36. Power-Supply Connections

NOTE: The DCIN connection on pin 1 is not used. Only the +5 V DC and ground power supply connections are needed as shown.

NOTE: If you are using a separate DC power supply for +5 V to the Relay Card because you are not drawing this power from the master, note that the crimp pins used in the friction-lock connector assembly can only hold one wire each. Connect the one GND wire from the friction-lock connector assembly to the ground on one of the two power supplies, then use a separate wire to connect the power-supply grounds together.

Use 18-gauge (AWG) wire (1 mm^2) for power-supply connections up to 10 m away from the master or router. If the wire length is less than 3 m, 22 gauge (AWG) wire (0.4 mm^2) is acceptable. Do not daisy-chain the power supply connections between different peripheral cards, but use a star configuration from the master or router when there are several peripheral cards.

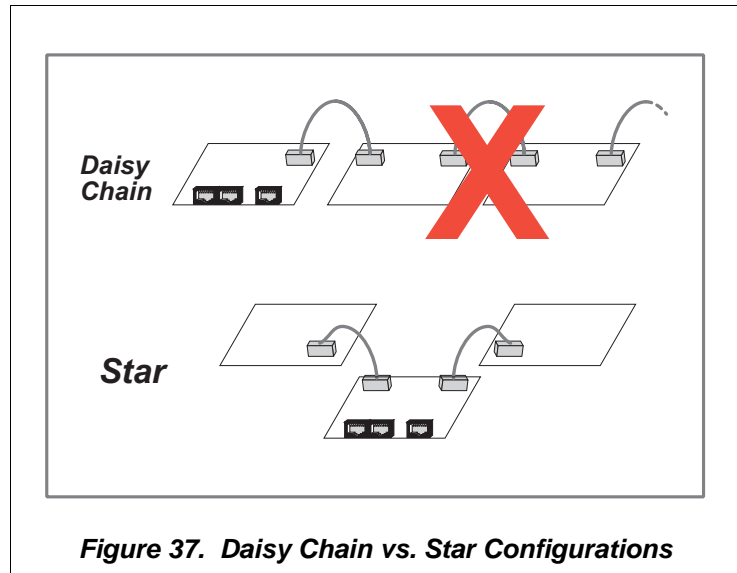

Figure 37. Daisy Chain vs. Star Configurations

It is best to use a type of cable where the wires for the ground and positive(s) of any power supply are bound together or twisted, and ideally the power-supply wires should not be bundled with other wires.

Large transient currents flow in the ground and positive supply wires when the relay output drivers are switched on/off, and it is imperative that any ground differential resulting from resistive or inductive loss in the ground wire be kept as low as possible ($<4 \text{ V}$). Use the GND pin on header J7 on the Relay Card if you have separate power supplies. Rabbit Semiconductor also recommends that you have a physical ground connection between the Relay Card and the master, which you will have if the power to header J7 on the Relay Card already comes from the master.

5.3 Pinout

The Relay Card pinouts are shown in Figure 38.

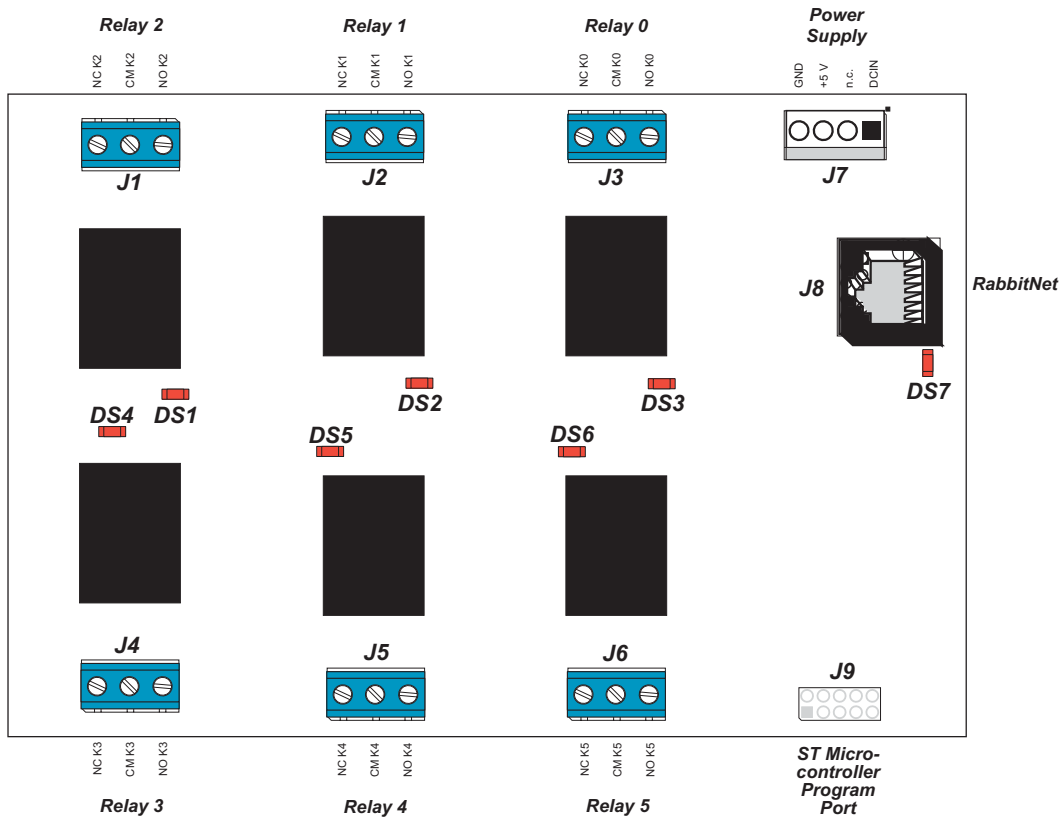

Figure 38. Relay Card Pinouts

5.3.1 Headers

Relay Cards are equipped with six screw-terminal headers (J1–J6), a 1 × 4 friction-lock terminal (J7—DCIN and +5 V power supplies), and an RJ-45 RabbitNet jack.

No header is installed at J9, which is used to program the Relay Card at the factory.

5.3.2 Indicator LEDs

An indicator LED (DS7) located below the RabbitNet connector at J8 turns on when the Relay Card is powered up, then goes off when the Relay Card has completed its initialization process and is running. The LED will be on while the Relay Card is receiving a transmission from the master.

Additional indicator LEDs (DS1–DS6) located near each relay will turn on while the corresponding relay (Relay 1 – Relay 6) is energized.

5.4 Relay Outputs

The Relay Card has six SPDT relays, each of which is rated to handle up to 250 V AC, 1200 V·A (max. 10 A) or up to 30 V DC, 240 W (max. 8 A). Each relay draws approximately 83 mA from the +5 V power supply when energized. This current draw can be reduced by approximately a factor of two by using the `rn_RelayPwr()` function call to engage the power-save mode once a relay is energized.

Figure 39 illustrates one of the six relay output circuits. An LED is associated with each relay, and is on while the relay is energized.

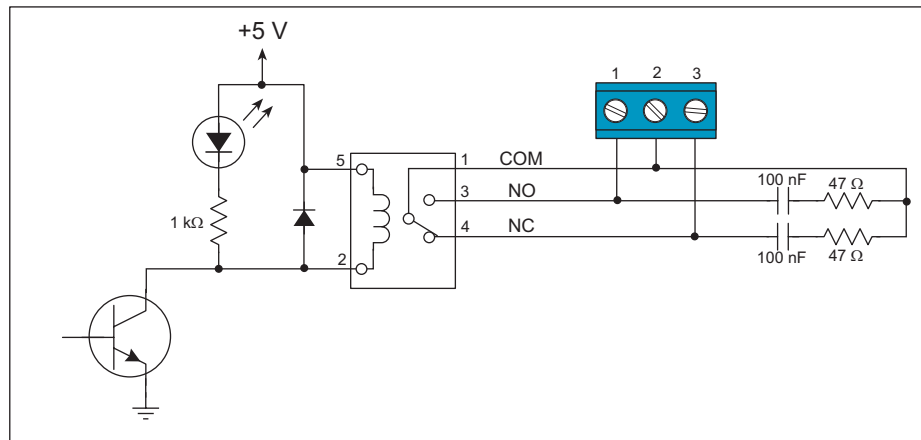

Figure 39. Relay Output Circuit



CAUTION: Voltages up to 250 V AC may be present on the screw-terminal headers. Exercise appropriate care when handling a wired Relay Card.

Since a wired Relay Card is likely to be installed as part of an assembly inside an enclosure, Rabbit Semiconductor recommends that appropriate warning labels be placed on the enclosure to alert the end-user of the high-voltage hazard and to refer any repairs or maintenance to a qualified service technician.

Each relay has built-in snubbers, which consist of a resistor and a capacitor in parallel with the contacts to reduce arcing. Although the original role of the snubbers was to preserve the life of the relay contacts by reducing arcing, snubbers are particularly beneficial in circuits driving inductive loads, where they limit voltage transients and reduce electromagnetic interference.

Depending on the reactive load you plan to operate with the Relay Card, you may want to change the resistor and capacitor values used for the built-in snubber circuit. This can be done easily since all the resistors and capacitors used in the snubber circuits are through-hole parts.

5.5 Software

This section provides the libraries, function calls, and sample programs related to the Relay Card.

5.5.1 Dynamic C Libraries

In addition to the library associated with the master single-board computer such as the BL2500 or OP7200, one other library is needed to provide function calls for the Relay Card.

- **RNET_RELAY.LIB**—provides functions unique to the Relay Card. Function calls for this library are discussed in this chapter.

Functions relevant to RabbitNet peripheral cards in general are described in Section 1.3.4. Other functions applicable to all devices based on Rabbit microprocessors are described in the *Dynamic C Function Reference User's Manual*.

5.5.2 Sample Programs

Sample programs are provided in the Dynamic C **SAMPLES** folder.

The various folders contain specific sample programs that illustrate the use of the corresponding Dynamic C libraries. For example, the sample program **PONG.C** demonstrates the output to the **STDIO** window.

To run a sample program, open it with the **File** menu (if it is not still open), then compile and run it by pressing **F9** or by selecting **Run** in the **Run** menu. The RabbitNet peripheral card must be connected to a master such as the BL2500 with its Demonstration Board connected as explained in the *Coyote (BL2500) User's Manual* or other user's manual. The BL2500 or other master must be in Program Mode, and must be connected via the programming cable to a PC.

The **SAMPLES\RABBITNET\RN1400** subdirectory contains the following sample programs. When running these sample programs, the Relay Card may be connected to either RabbitNet port on a master such as the BL2500 that has two RabbitNet ports. The sample program will use **rn_find()** and the product RN1400 as the search criteria to first find any Relay Cards connected to the master. The first Relay Card found will run the sample program.

- **RELAY_ALL.C**—Demonstrates how to activate all the relays in parallel using the **rn_RelayAll()** function call.



CAUTION: Activating several relays in a short period of time may cause a power surge that may exceed the peak power rating of your power supply. Be sure that your power supply can handle at least 500 mA when using this sample program.

Once you have compiled this sample program and it is running, use **F2** to set a breakpoint on either of the following two statements in **mainline** for a given relay to verify the relay connections:

```
printf("All Relays COM is connected to its NO contact\n");
```

or

```
printf("All Relays COM is connected to its NC contact\n");
```

Once you hit the breakpoint use an ohmmeter to verify that the contacts are connected, the ohmmeter reading should be $\sim 0 \Omega$ for contacts that are connected and high impedance for the contacts that are *not* connected.

NOTE: When the relays are toggled, the LED for the given relay will also be toggled.

- **RELAY_LOW_PWR.C**—Demonstrates how to configure the relays to operate in the power-save mode. A relay is first activated normally for 50 ms, and is then pulsed every millisecond with a 50% duty-cycle square wave, which essentially cuts the power required to keep the relay energized in half. Since the operation of a relay in the power-save mode will reduce the relay-holding force, this mode is not recommended when the relay may be subject to shock and vibration.

The normal relay-activation current is ~ 80 mA, which is reduced to ~ 40 mA for a given relay with the power-save mode.

Before you run this sample program, place an ammeter in series with the power-supply GND lead going to the Relay Card to verify that current drawn by the relay is in fact reduced in the power-save mode.

Now compile and run this program. Watch the ammeter and the Dynamic C **STDIO** window to view the current readings for the various relay states.

- **RELAY_SEQUENCE.C**—Demonstrates how to activate the relays sequentially to keep the peak power surges to a minimum while the relays are being activated.

Once you have compiled this sample program and it is running, select the set of relays to activate in the Dynamic C **STDIO** window. Watch the relay LEDs to verify visually that the relays are being sequenced.

5.5.3 Relay Card Function Calls



CAUTION: Activating several relays in a short period of time may cause a power surge that may exceed the peak power rating of your power supply. It is ultimately the responsibility of the application designer to ensure that the power supply meets the requirements for the intended application.

Also note that the power-save mode will reduce the holding force for the relay contacts. Rabbit Semiconductor recommends that you *not* use the power-save mode when the Relay Card is expected to be subject to shock and vibration.

```
int rn_Relay(int handle, int relay, int value,  
            int reserved);
```

Sets the state of a given relay by connecting the relay common contact to either the relay normally closed contact or to the relay normally open contact.

PARAMETERS

handle is an address index to device information. Use `rn_device()` or `rn_find()` to establish the handle.

relay is the selected relay (0–5).

value is used to set a given relay connection as follows:

0 = common connected to normally closed contact

1 = common connected to normally open contact

reserved is reserved for future use. Set to 0.

RETURN VALUE

The status byte from the previous command. -1 means that device information indicates the Relay Card is not connected to the master.

SEE ALSO

`rnRelayAll`, `rnRelayPwr`

```
int rn_RelayAll(int handle, int control,
                int reserved);
```

Sets the state of all the relays with the given bitwise control value. Connects the relay common contact to either the relay normally closed contact or to the relay normally open contact.

PARAMETERS

handle is an address index to device information. Use `rn_device()` or `rn_find()` to establish the handle.

control establishes the bitwise control of Relays 0–5. The bit positions 0–5 correspond directly to Relays 0–5, with the bit value controlling the relay as follows:

0 = common connected to normally closed contact

1 = common connected to normally open contact

reserved is reserved for future use. Set to 0.

RETURN VALUE

The status byte from the previous command. -1 means that device information indicates the Relay Card is not connected to the master.

SEE ALSO

`rnRelayPwr`, `rnRelay`

EXAMPLE

```
rn_RelayAll(handle, 0x05, 0);
// Sets the relays to have the following connections:
    Relay0...Common connected to Normally Open contact
    Relay1...Common connected to Normally Closed contact
    Relay2...Common connected to Normally Open contact
    Relay3...Common connected to Normally Closed contact
    Relay4...Common connected to Normally Closed contact
    Relay5...Common connected to Normally-Closed contact
```

```
void rn_RelayPwr(int handle, int control,
                int reserved);
```

Sets the specified relays to be in a power reduction/save mode. The power-save mode is activated after the relay has been active for at least 50 ms, after which the relay will be pulsed every 1 ms with a 50% duty cycle square wave, which should provide a power reduction of 50% for the given relay.

If this function isn't called, the relays will operate without going into the power-save mode of operation.

PARAMETERS

handle is an address index to device information. Use `rn_device()` or `rn_find()` to establish the handle.

control establishes the bitwise control of Relays 0–5. The bit positions 0–5 correspond directly to Relays 0–5, with the bit value controlling the relay as follows:

- 0 = set relay for normal operation
- 1 = set relay for power-save mode

reserved is reserved for future use. Set to 0.

RETURN VALUE

The status byte from the previous command. -1 means that device information indicates the Relay Card is not connected to the master.

SEE ALSO

`rnRelayAll`, `rnRelay`

EXAMPLE

```
rn_RelayPwr(handle, 0x05, 0);
// Sets the relays for the following operation:
Relay0.....Set to power-save mode
Relay1.....Set for normal operation
Relay2.....Set to power-save mode
Relay3.....Set for normal operation
Relay4.....Set for normal operation
Relay5.....Set for normal operation
```

5.5.4 Status Byte

Section 1.3.5 provides information on the status bytes returned by various function calls.

5.6 Specifications

5.6.1 Electrical and Mechanical Specifications

Figure 40 shows the mechanical dimensions for the Relay Card.

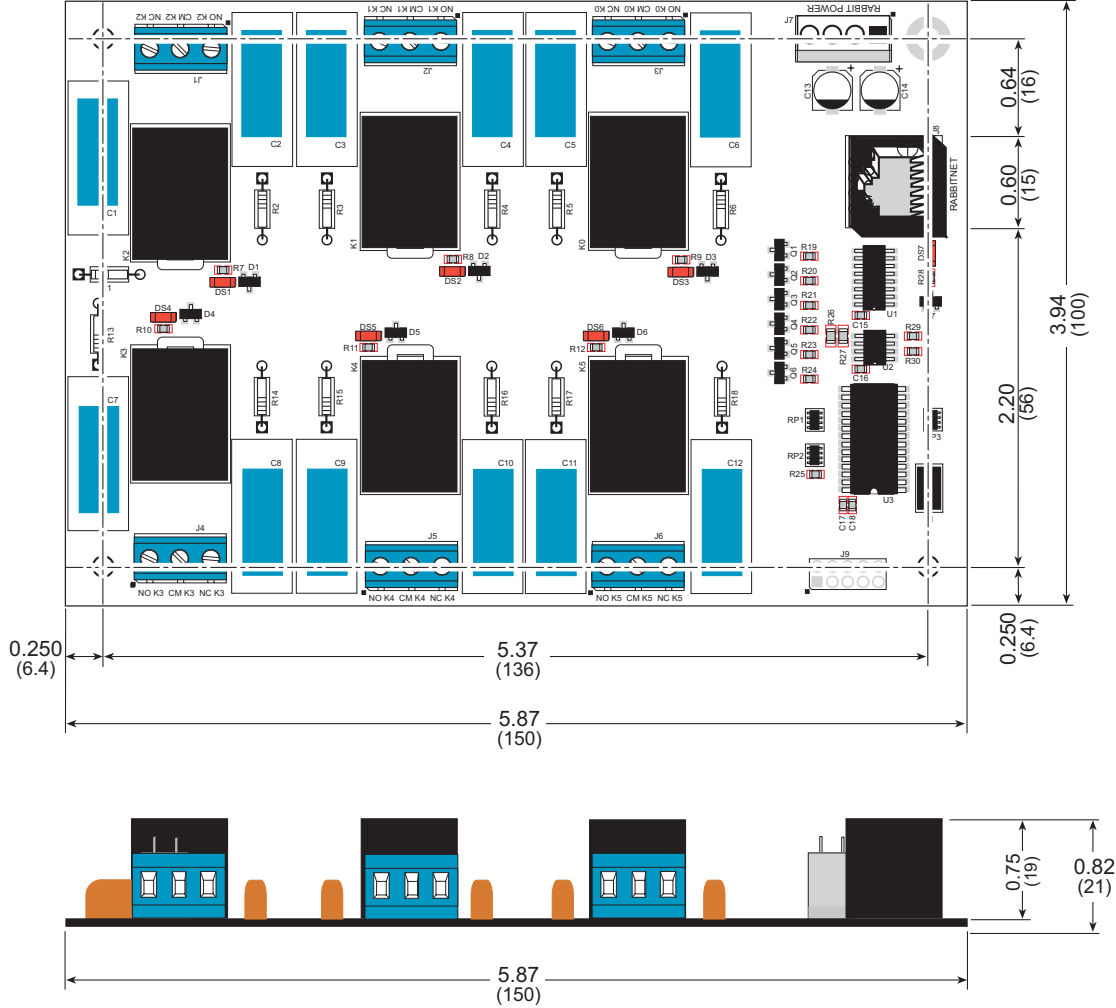

Figure 40. Relay Card Dimensions

NOTE: All diagram and graphic measurements are in inches followed by millimeters enclosed in parentheses.

Table 10 lists the electrical, mechanical, and environmental specifications for the Relay Card.

Table 10. Relay Card Specifications

Feature	Specification
Microprocessor	ST72F264G
Relay Outputs	Six SPDT relays with snubbers: <ul style="list-style-type: none"> • max. contact settling time: 10 ms • max. switching voltage: 250 V AC, 30 V DC • max. switching current: 10 A AC, 8 A DC • max. switching capability: 1200 V·A • snubbers: built-in 47 Ω, 100 nF • terminal wire gauge: #14 AWG (1.628 mm dia.) max.
RabbitNet™ Serial Port	RS-422, 1 Mbits/s
Power	Vcc: +5 V DC, 500 mA (all relays energized)
Temperature	-40°C to +70°C
Humidity	5% to 95%, noncondensing
Connectors	Six screw-terminal headers Friction-lock connectors: <ul style="list-style-type: none"> • one 4-position terminal with 0.156" pitch One RJ-45 RabbitNet™ jack
Board Size	3.94" × 5.87" × 0.82" (100 mm × 150 mm × 21 mm)

5.6.2 Physical Mounting

Figure 41 shows position information to assist with interfacing other boards with the Relay Card.

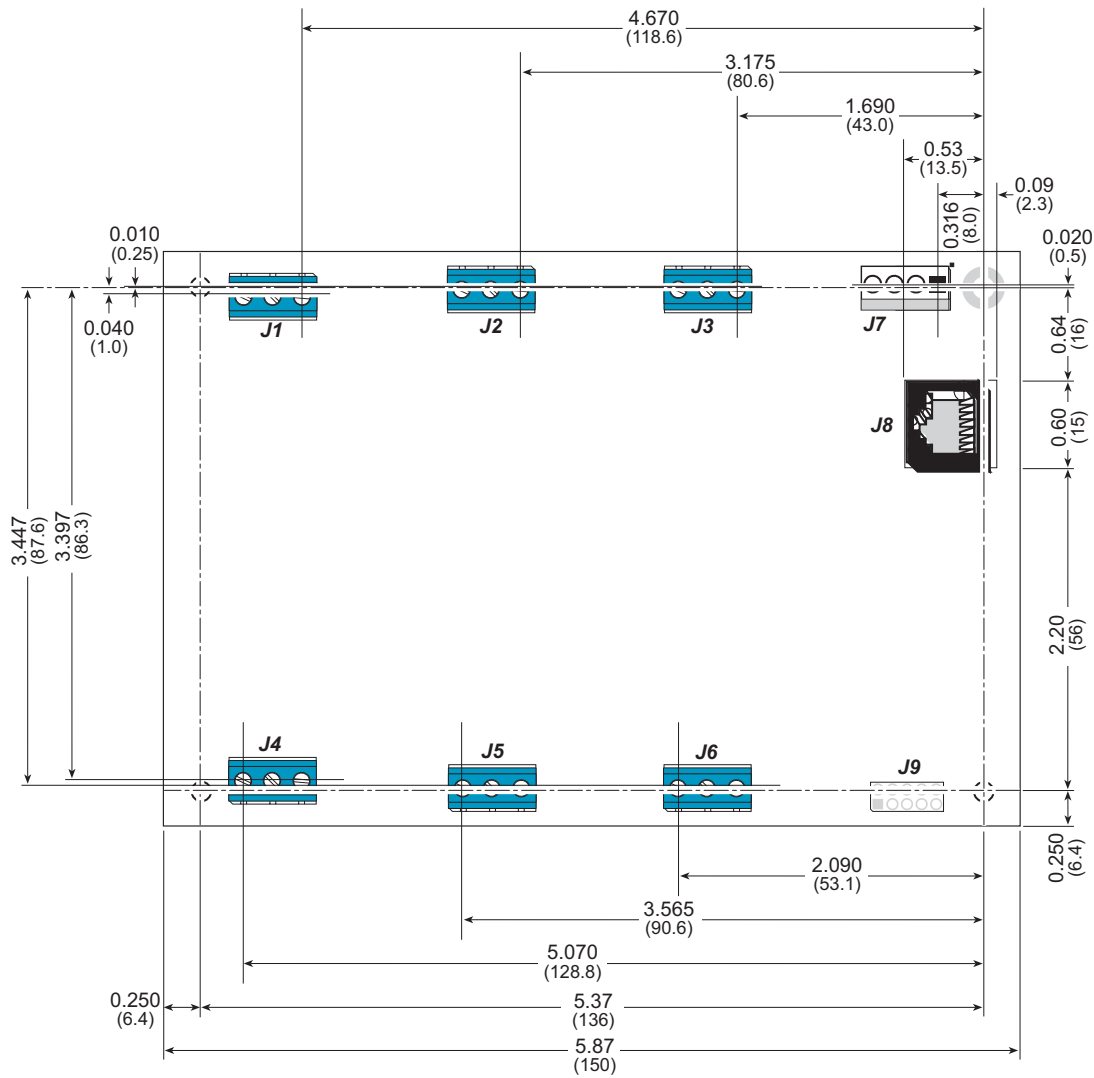

Figure 41. User Board Footprint for Relay Card

6. KEYPAD/DISPLAY INTERFACE

Chapter 6 describes the features and the use of the RabbitNet Keypad/Display interface, one of the peripheral cards designed for use with the RabbitNet expansion ports on selected Rabbit Semiconductor single-board computers, operator interfaces, and RabbitCore Prototyping Boards.

Figure 42 shows a conceptual view of the RabbitNet Keypad/Display interface connected to a master.

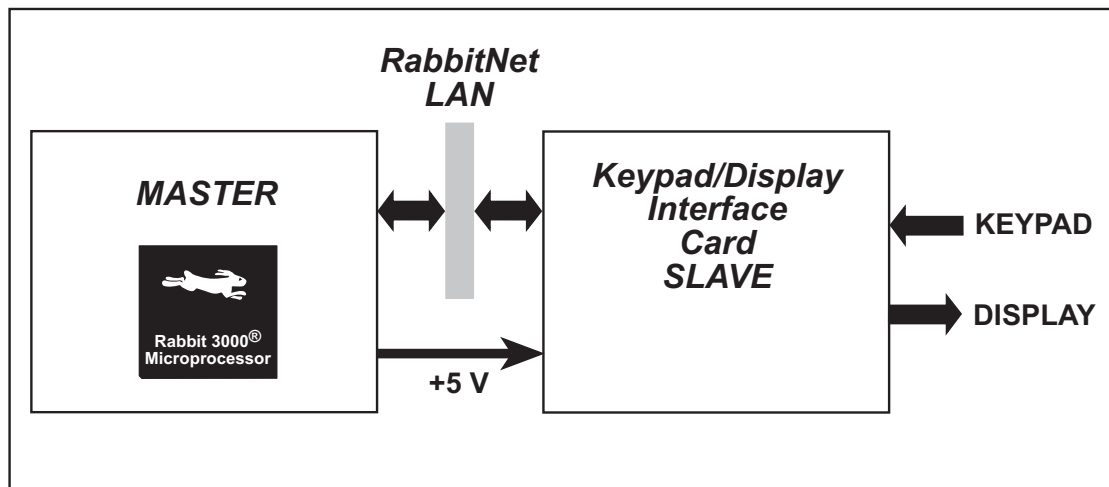

Figure 42. RabbitNet Keypad/Display Interface (Slave) Connected to Master

NOTE: Only one RabbitNet Keypad/Display interface per master is supported at this time.

NOTE: The OP7200 master and the RabbitCore Prototyping Boards do *not* supply any power to the slave.

6.1 Features

- accepts one generic keypad with a maximum of 16 terminals, a maximum of 64 keys in an 8×8 matrix, and with a flex connector tail whose traces are spaced 0.1" center-to-center.
- supports one character liquid crystal display with up to 4×20 characters with or without a backlight, accepts standard 1×16 or 2×8 connectors with 0.1" pitch.
- onboard series resistance configuration for backlight LEDs on liquid crystal display
- onboard contrast adjustment for liquid crystal display
- 5 LED status indicators.
- can be mounted in standard 100 mm DIN rail trays sold by other suppliers
- Interfaces with master through RabbitNet™ serial protocol at 1 Megabit per second using standard Ethernet cable, can be up to 10 m (33 ft) away from master

6.1.1 Software

The RabbitNet Keypad/Display interface is a preprogrammed slave; the master to which it is connected is programmed using version 8.50 or later of Rabbit Semiconductor's Dynamic C. If you are using a BL2500 or an OP7200 as your master with an earlier version of Dynamic C, Rabbit Semiconductor recommends that you upgrade your Dynamic C installation. Contact your authorized Rabbit Semiconductor distributor or your Rabbit Semiconductor Sales Representative for more information on Dynamic C upgrades.

6.2 Connections

Use a straight-through CAT 5/6 Ethernet cable to connect the RabbitNet Keypad/Display interface RJ-45 RabbitNet jack to a RabbitNet port on the master. You may use either port if you are connecting to a BL2500 or other master that has two RabbitNet ports.

NOTE: The RJ-45 *RabbitNet* jacks are serial I/O ports for use with a master and a network of peripheral cards. The *RabbitNet* jacks do *not* support connections to an Ethernet network.

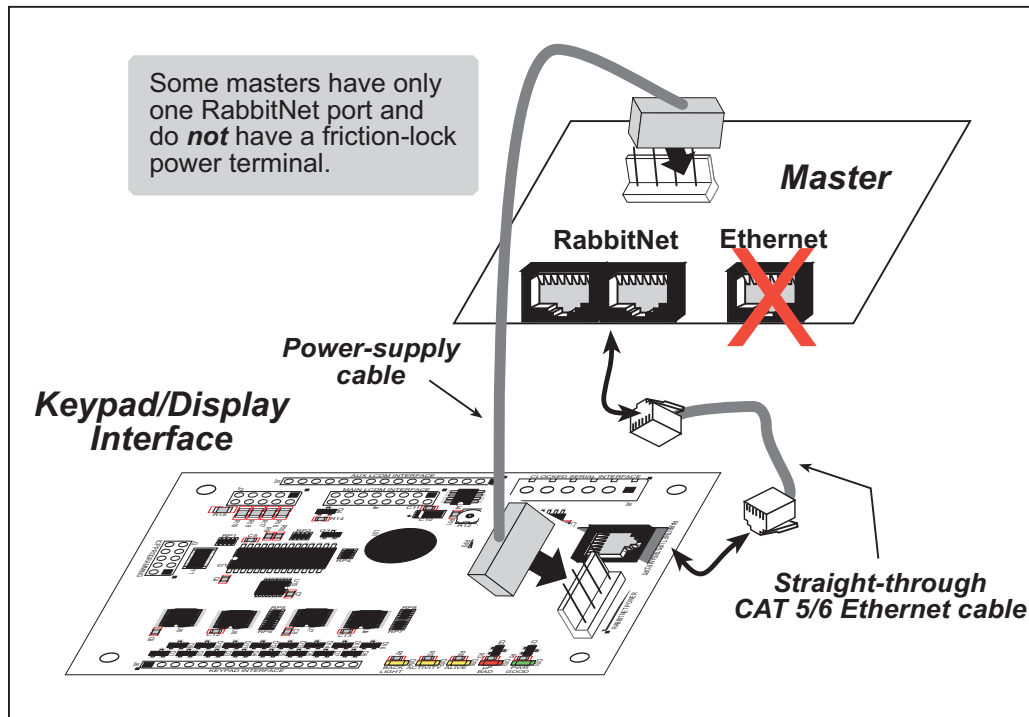

Figure 43. Connect RabbitNet Keypad/Display Interface to Master

You will also have to provide +5 V DC power to your RabbitNet Keypad/Display interface. The power supply is connected via the friction-lock terminal at header J1. If you are using a BL2500 or BL2600 as your master, you may draw this power from the BL2500 or BL2600 as shown in Figure 43. You may assemble a suitable cable using the friction-lock connectors from the Connectivity Kit described in Section 1.1.3. Although there is a standard RabbitNet DCIN power-supply input on the RabbitNet Keypad/Display interface, the interface does not need DCIN power.

NOTE: Even if you are not drawing power from a BL2500 or BL2600 master, you will need to at least connect the RabbitNet Keypad/Display interface ground to the ground on your master. The GND pin on header J1 should be used.

At the present time, the number of peripheral cards you can use with one master is limited by the number of RabbitNet ports on the master. Only one Keypad/Display interface per master is supported at the present time.

6.2.1 Power Supply

Figure 44 illustrates the assembled friction-lock connector wiring diagram for the power supplies used to supply power to the RabbitNet Keypad/Display interface. DCIN (pin 1 on header J1) is not used by the Keypad/Display interface, and does not have to be connected.

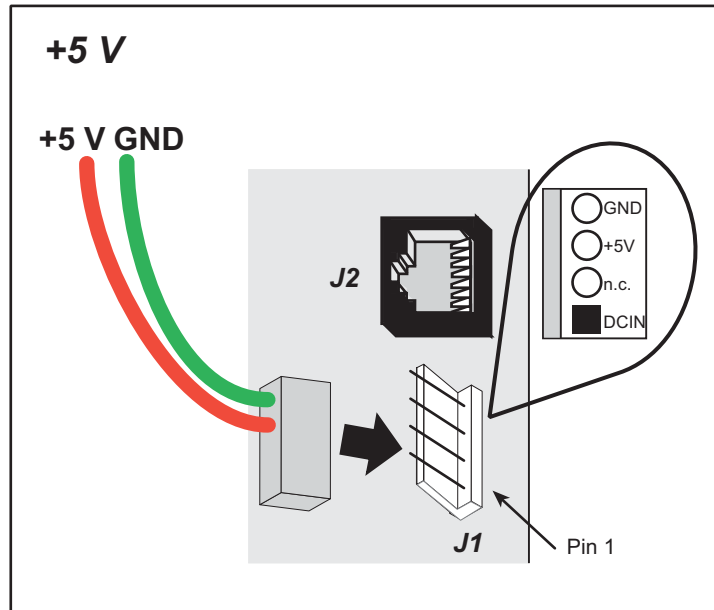

Figure 44. Power-Supply Connections

Use 18-gauge (AWG) wire (1 mm²) for power-supply connections up to 10 m away from the master. If the wire length is less than 3 m, 22 gauge (AWG) wire (0.4 mm²) is acceptable. Do not daisy-chain the power supply connections between different peripheral cards, but use a star configuration from the master when there are several peripheral cards.

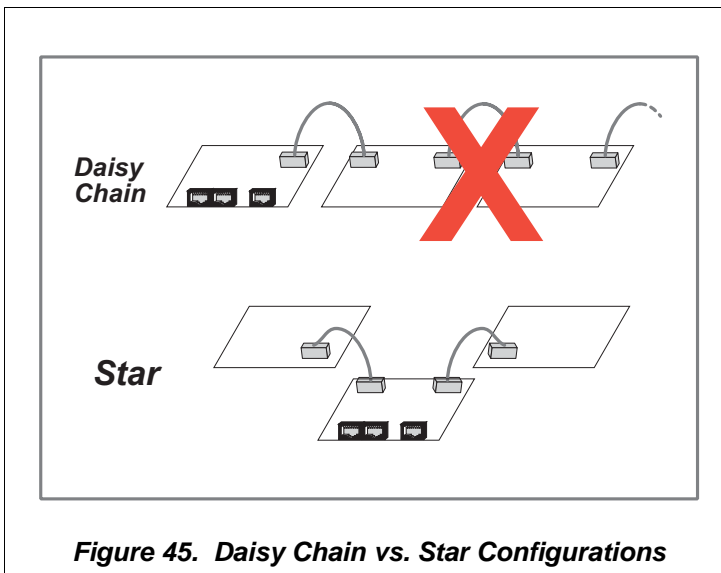

Figure 45. Daisy Chain vs. Star Configurations

It is best to use a type of cable where the wires for the ground and positive(s) of any power supply are bound together or twisted, and ideally the power-supply wires should not be bundled with other wires.

If you are not drawing power from the master, we strongly recommend that you have a physical ground connection between the Keypad/Display interface and the master.

6.3 Key RabbitNet Keypad/Display Interface Components

Figure 46 shows the locations of key RabbitNet Keypad/Display interface components.

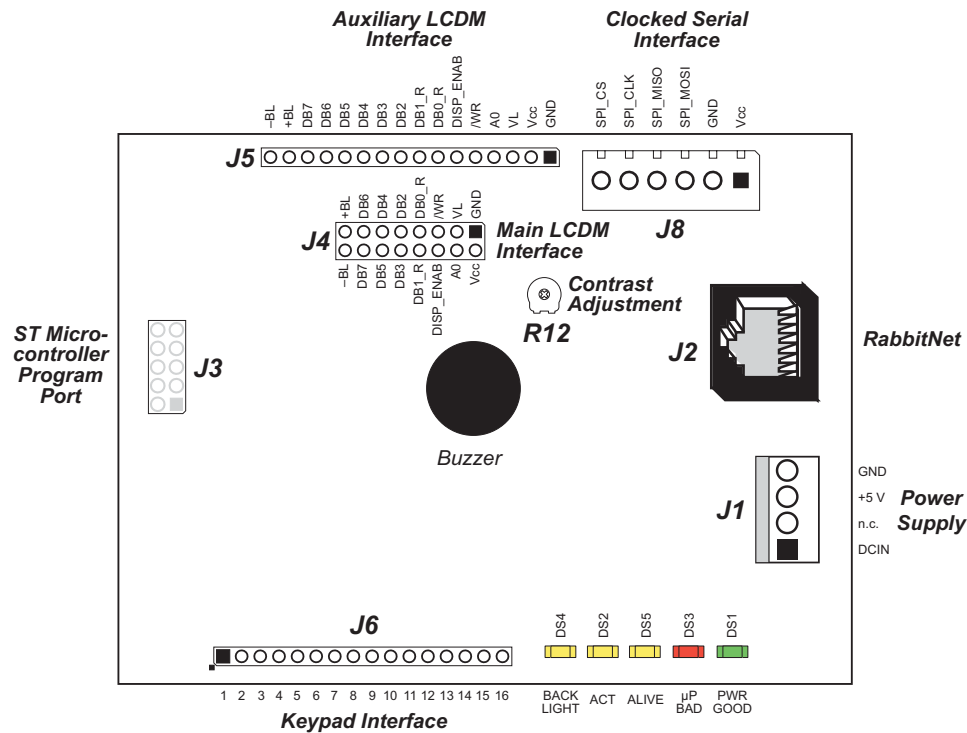

Figure 46. RabbitNet Keypad/Display Interface Pinouts

6.3.1 Headers and Jacks

RabbitNet Keypad/Display interfaces are equipped with one 1×4 friction-lock terminal at J1 (DCIN and +5 V power supplies), and an RJ-45 RabbitNet jack.

No header is installed at J3, which is used to program the onboard microcontroller at the factory. No header is installed at J8, which is reserved for future use.

6.3.1.1 Keypads

A 1×16 IDC header at J6 with a 0.1" pitch provides the keypad interface, and can accommodate keypads with up to 16 leads. A maximum of 64 keys can be handled in an 8×8 matrix.

To insure compatibility with the software driver routines, pin 1 on header J6 must always be connected to a keypad strobe or data line; do not leave pin 1 unconnected.

Manufacturers typically supply keypads with flex connector tails, and can usually be ordered with or without a connector on the flex connector tail. The traces on the connector tails are most often spaced 0.1" center-to-center, and this is the only spacing supported by the RabbitNet Keypad/Display interface since the pins on header J6 are spaced 0.1" apart. Suitable keypads will not necessarily use all the pins that are available on header J6, but will work as long as they meet the other criteria described in this section.

FCI/Berg is one manufacturer of connectors that may be used to connect the flex connector tails from the keypad to header J6 on the Keypad/Display interface. Their connectors, called series 65801 “Clincher,” are available in various widths and may be purchased online from [Mouser Electronics](#).

It is expensive to develop a custom keypad, particularly if the anticipated volume will be low. A good source for generic keypads is Xymox Technologies Inc. 9099 W. Dean Rd., Milwaukee, WI 53224. Their available keypads can be viewed online by visiting their Web site at www.xymox.com and searching for “stock membrane switches.”

6.3.1.2 Liquid Crystal Displays

A 2×8 IDC header at J4 and a 1×16 socket at J5 with a 0.1" pitch provide the interface for character liquid crystal displays either with or without a backlight. A standard signal pin assignment is used by most manufacturers for each of the two types of connectors. The command set is the same across all character liquid crystal displays.

Pins 15 and 16 are reserved for the backlight function. In some cases when there is no backlight or the backlight is internal to the liquid crystal display, the manufacturer sometimes uses a 1×14 in-line or a 2×14 dual-row connector. In this case, pins 15 and 16 on the Keypad/Display interface are not used, and you need to only connect pins 1–14 to the corresponding pins on the liquid crystal display.

6.3.2 LEDs

The RabbitNet Keypad/Display interface has five status LEDs: **Backlight**, **Activity**, **Alive**, **Microprocessor Bad**, and **Power Good**.

The **Backlight** LED at DS4 turns on to indicate that the backlight was turned on by the `rn_dispBacklight()` software function call.

The **Activity** LED at DS2 indicates network activity in that data are being transferred between the Keypad/Display interface and the master.

The **Alive** LED at DS5 blinks continuously once the onboard microprocessor has performed its self-tests and is running properly. The microprocessor is not working properly if this LED remains either on or off.

The red **Microprocessor Bad** LED at DS3 indicates the status of the RabbitNet Keypad/Display interface. Following a reset, DS4 will be ON and will remain ON while the microcode on the onboard microprocessor performs its self-tests. This LED is turned off if the self-test completes successfully, and can subsequently be user-controlled in the application.

The green **Power Good** LED at DS1 indicates when power is applied to the RabbitNet Keypad/Display interface and that Vcc is above 3.6 V. The LED turns off when the RabbitNet Keypad/Display interface is being reset.

6.3.3 Buzzer

An audible buzzer can be turned on in software for variable intervals of time.

6.4 Liquid Crystal Display Backlights

Liquid crystal displays are manufactured with and without backlighting. Electroluminescent (EL), cold-cathode fluorescent (CCFL), vacuum fluorescent (VFD), or LED backlighting are the types of backlighting available. The RabbitNet Keypad/Display interface supports only LED backlighting because this is the most common type and is the most likely to require external support.

Liquid crystal displays with LED backlighting derive their voltage or current via pins 15 and 16 of header J4 or J5. In those cases where a voltage source is used, the Keypad/Display interface can be configured to supply 5 V to the liquid crystal display. Series resistors on the liquid crystal display limit the current to the LED backlight and set its intensity. To provide the 5 V voltage source, install 2-pin jumpers across pins 7–8 and 9–10 on header J7.

When the LCD backlight specifications call for a current source, the series resistors on the Keypad/Display interface are used to limit the current. The series resistance can be set from 3.3 Ω to 20 Ω with the 2-pin jumpers on header J7. The liquid crystal display specifications list the voltage required across its internal LEDs and indicate the allowable range of current corresponding to the LED intensity. Subtract this LED voltage from 5 V, then divide that by the current for the selected LED intensity to determine the required series resistance. Install 2-pin jumpers on header J7 to configure the resistance value closest to that calculated without exceeding the maximum current in the specification. Table 11 gives the resistance values and maximum current corresponding to various jumper settings.

Table 11. Header J7 Pins to Jumper to Configure LCD Series Resistance

Resistance	Header J7 Pins					Max. Current (mA)
	1–2	3–4	5–6	7–8	9–10	
0.00 Ω						350
3.33 Ω						333
5.00 Ω^*						222
10.0 Ω						111
13.3 Ω						111
15.0 Ω						111
20.0 Ω						111
infinite						0

* Factory default.

NOTE: Make sure that the jumpers are set appropriately before connecting the liquid crystal display to the Keypad/Display interface. The backlight on your liquid crystal display may be destroyed when subjected to a current above the maximum specified. Pay close attention when using the 0 Ω resistance setting to source 5 V to the LCD.

Figure 47 shows the header and jumper locations used to set the current required by an LED backlight on a display.

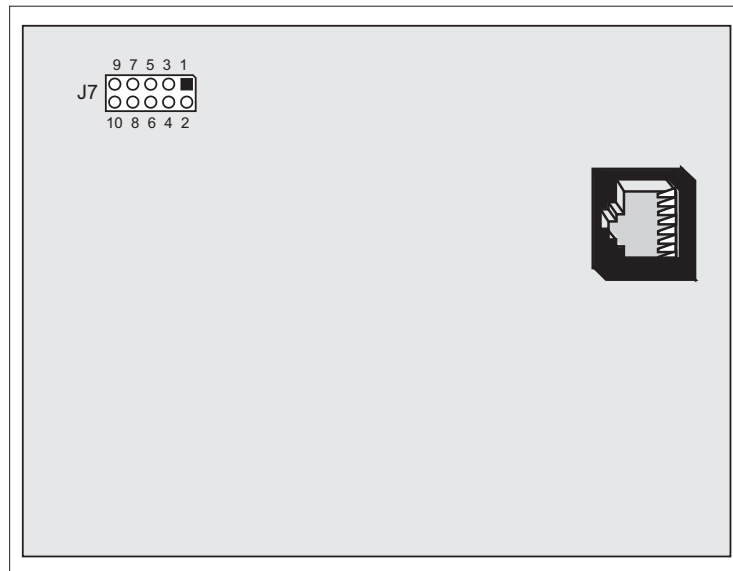

Figure 47. Location of RabbitNet Keypad/Display Interface Resistor Configurations

Example

For example, let's consider a case where the specifications indicate that the typical LED voltage is 4.2 V and the typical LED backlight current is 200 mA.

1. Subtract 4.2 V from 5 V:

$$5.0 \text{ V} - 4.2 \text{ V} = 0.8 \text{ V}.$$

2. Divide by the current:

$$\frac{0.8 \text{ V}}{200 \text{ mA}} = 4 \Omega$$

Choose the next higher resistance, 5 Ω , which is the default factory setting. As a sanity check, the maximum current in Table 11 for this configuration is 222 mA, and so the backlight current of 200 mA is safely below the maximum.

6.5 Display Contrast

Each different size and configuration of a liquid crystal display often requires a unique contrast setting. Even otherwise identical liquid crystal displays with the same part number from the same vendor sometimes require different settings. The contrast or viewing angle of the liquid crystal display can be adjusted using potentiometer R12 on the Keypad/Display interface.

The contrast setting is sensitive and can be somewhat difficult to achieve until some experience is obtained. A good way to set the contrast is to first connect the liquid crystal display to the RabbitNet Keypad/Display interface, and then power up the complete RabbitNet system. Do not run any of the sample programs at this time. Adjust the contrast potentiometer until the liquid crystal display shows 1 or 2 rows of fully filled character cells. Now run one of the sample programs that corresponds to the liquid crystal display being used and further adjust R12 for optimum contrast.

6.6 Software

This section provides the libraries, function calls, and sample programs related to the RabbitNet Keypad/Display interface.

6.6.1 Dynamic C Libraries

In addition to the library associated with the master single-board computer such as the BL2500 or OP7200, two other libraries are needed to provide function calls for the RabbitNet Keypad/Display interface.

- **RNET_KEYIF.LIB**—provides function calls for the RabbitNet Keypad/Display keypad interface. These function calls are described in this chapter.
- **RNET_LCDIF.LIB**—provides function calls for the RabbitNet Keypad/Display LCD display interface. These function calls are described in this chapter.

Functions relevant to RabbitNet peripheral cards in general are described in Section 1.3.4. Other functions applicable to all devices based on Rabbit microprocessors are described in the *Dynamic C Function Reference User's Manual*.

6.6.2 Sample Programs

Sample programs are provided in the Dynamic C **SAMPLES** folder.

The various folders contain specific sample programs that illustrate the use of the corresponding Dynamic C libraries. For example, the sample program **PONG.C** demonstrates the output to the **STDIO** window.

To run a sample program, open it with the **File** menu (if it is not still open), then compile and run it by pressing **F9** or by selecting **Run** in the **Run** menu. The RabbitNet peripheral card must be connected to a master such as the BL2500 with its Demonstration Board connected as explained in the *Coyote (BL2500) User's Manual* or other user's manual. The BL2500 or other master must be in Program Mode, and must be connected via the programming cable to a PC.

The **SAMPLES\RABBITNET\RN1600** subdirectory contains the following sample programs. You will need to install the specified keypad and/or the specified display provided in the RabbitNet Keypad/Display Interface Expansion Kit before you run these sample programs. Appendix A provides details and diagrams showing how to attach the appropriate keypad or LCD display needed to run a sample program. Each sample program has complete setup and operating instructions.

- **ALPHANUM.C**—Demonstrates the use of the 2 × 6 keypad and the 4 × 20 display provided in the RabbitNet Keypad/Display Interface Expansion Kit. The sample program demonstrates how you can create messages with the keypad and then display them on the LCD.
- **BUZZER.C**—Demonstrates control of the buzzer on the RabbitNet Keypad/Display interface by using the function calls **rn_keyBuzzer()** and **rn_keyBuzzerAct()**. Although the buzzer is monotone, some pitch and motorboat effects can be demonstrated with this sample program.

- **KEYBASIC.C**—Demonstrates the keypad function using the 4 × 10 keypad provided in the RabbitNet Keypad/Display Interface Expansion Kit. The sample program demonstrates the following features.
 - Custom ASCII keypad return values.
 - Use of the buzzer on the RabbitNet Keypad/Display interface.
 - Keypad character assignment for a specific example provided.

Once you compile and run this program, press each key on the keypad. The results are displayed in the Dynamic C **STDIO** window.

- **LCDBASIC.C**—Demonstrates the use of the 2 × 20 display provided in the RabbitNet Keypad/Display Interface Expansion Kit. The sample program demonstrates various display functions. Note that the backlight function will work only on displays that are equipped with a backlight.
- **PONG.C**—Demonstrates the use of the 3 × 4 keypad and the 2 × 20 display provided in the RabbitNet Keypad/Display Interface Expansion Kit.
- **ZMENU.C**—Demonstrates a menu system that allows you to list a set of action options for an operator to choose from. Keypads and character displays included in the Expansion Kit are used with this program. All the parameters required for the menu system can be changed via the `Zmenu_Config()` function included with the sample program.

This sample program has three menus, a main menu, a data-entry menu, and a TCP/IP menu. The main menu allows you to select either of the other two menus, and includes provisions for erasing the **STDIO** window and for turning the backlight on or off if the character display is equipped with a backlight. Depending on the actual display, you may have to scroll down to see all the options. The data-entry menu demonstrates the data-entry capability for longs, floats, strings, passwords, and a time/date stamp. The TCP/IP menu demonstrates how to change IP addresses via the keypad.

As selections are made, the current menu number and the selection made are displayed in the **STDIO** window. When a data entry or a TCP/IP menu selection is made, the appropriate values entered are also displayed in the **STDIO** window.

The **ZMENU.C** sample program is built around the `Zmenu_Config()` function, which is described in Appendix A.3.

6.6.3 RabbitNet Keypad/Display interface Function Calls

The RabbitNet Keypad/Display interface uses keypad function calls that are similar to those used by other Rabbit Semiconductor devices such as the OP6800, the OP7200, and the LCD/keypad module.

6.6.3.1 Buzzer

The buzzer on the RabbitNet Keypad/Display interface can be programmed in software to sound for specified time intervals or to provide an audible click when a keypress occurs. These function calls are provided in the `RNET_KEYIF.LIB` library.

```
int rn_keyBuzzer(int handle, int onOff, int reserved);
```

Turns the buzzer on or off. This function will override any setting by `rn_keyBuzzerAct`. Calling `rn_keyBuzzer` does not affect the keypress buzzer setting.

PARAMETERS

handle is an address index to device information. Use `rn_device()` or `rn_find()` to establish the handle.

onOff is the buzzer on/off control

0—buzzer off

1—buzzer on

reserved is reserved for future use. Set to 0.

RETURN VALUE

The status byte from the previous command. -1 means that device information indicates the Keypad/Display interface is not connected to the master.

SEE ALSO

`rn_keyBuzzerAct`

```
int rn_keyBuzzerAct(int handle, unsigned int period, int reserved);
```

Activates the buzzer for a specified interval of time. `rn_Buzzer()` will override this function. Calling `rn_keyBuzzerAct()` does not affect the keypress buzzer setting.

PARAMETERS

handle is an address index to device information. Use `rn_device()` or `rn_find()` to establish the handle.

period is the length of time the buzzer will be activated. Select 1–65535 ms

reserved is reserved for future use. Set to 0.

RETURN VALUE

The status byte from the previous command. -1 means that device information indicates the Keypad/Display interface is not connected to the master.

SEE ALSO

`rn_keyBuzzer`

6.6.3.2 LEDs

The functions used to control any LEDs are contained in the `RNET_KEYIF.LIB` library located in the Dynamic C `RABBITNET` library directory.

```
int rn_keyLedOut(int handle, int led, int onOff,  
int reserved);
```

The **Microprocessor Bad** LED is user-controllable and can be set to a specified state until called again.

PARAMETERS

handle is an address index to device information. Use `rn_device()` or `rn_find()` to establish the handle.

led is the LED to control. Use 0 for **Microprocessor Bad** LED.

onOff is the LED on/off control.

0 = LED Off

1 = LED On

reserved is reserved for future use. Set to 0.

RETURN VALUE

The status byte from the previous command. -1 means that device information indicates the Keypad/Display interface is not connected to the master.

SEE ALSO

`rn_keyBuzzer`

6.6.3.3 Keypad

The functions used to control the keypad are contained in the `RNET_KEYIF.LIB` library located in the Dynamic C `RABBITNET` library directory. This library supports keypads with up to 64 keys.

```
int rn_keyInit(int handle, unsigned int iobits,  
int buzzerperiod);
```

Initializes keypad and buzzer control for when a key is pressed. Call this function prior to any keypad operations. Calling this function more than once will reinitialize key-processing queues.

To ensure keypad driver compatibility, the keypad must be installed so that a strobe line or data line starts on J6 pin 1.

PARAMETERS

handle is an address index to device information. Use `rn_device()` or `rn_find()` to establish the handle.

iobits is a 16-bit number that consists of 1's for outputs and 0's for inputs. Each bit represents one of the 16 lines available for a keypad interface. For example, a value of `0x1F00` (= `0001111100000000`) assigns strobe lines to 13, 12, 11, 10, and 9 on header J6 of the Keypad/Display interface to serve as the output strobe lines. The other bit lines are either inputs or are unused.

buzzerperiod indicates how long the buzzer remains activated whenever a key is pressed.

0 = buzzer does not sound when a key is pressed

1–255 ms = enable the buzzer for the specified period for each keypress detected (a value of 10 produces a short click)

RETURN VALUE

-1 means that device information indicates the Keypad/Display interface is not connected to the master.

```
void rn_keyConfig(int handle, char cRaw,  
char cPress, char cRelease, char cCntHold,  
char cSpdLo, char cCntLo, char cSpdHi);
```

Assigns each key with key press and release codes, and hold and repeat ticks for auto repeat and debouncing.

To ensure keypad driver compatibility, the keypad must be installed so that a strobe line or data line starts on J6 pin 1.

PARAMETERS

handle is an address index to device information. Use `rn_device()` or `rn_find()` to establish the handle.

cRaw is a raw key code index, 0–63 for 1–64 keys. Because keypad configurations will differ, assign the raw code indexes according to your keypad configuration. For example:

2 × 6 keypad matrix with raw key code index assignments [in brackets]
[13][12][11][10][9][8]
[5][4][3][2][1][0]

4 × 10 keypad matrix with raw key code index assignments [in brackets]

```
[ 32 ][ 33 ][ 24 ][ 25 ][ 16 ][ 17 ][ 8 ][ 9 ][ 0 ][ 1 ]
[ 34 ][ 35 ][ 26 ][ 27 ][ 18 ][ 19 ][ 10 ][ 11 ][ 2 ][ 3 ]
[ 36 ][ 39 ][ 28 ][ 31 ][ 20 ][ 23 ][ 12 ][ 15 ][ 4 ][ 7 ]
[ 38 ][ 37 ][ 30 ][ 29 ][ 22 ][ 21 ][ 14 ][ 13 ][ 6 ][ 5 ]
```

cPress is a keypress code.

An 8-bit value or character is returned when a key is pressed.

0 = Unused.

For example:

```
[ 1 ][ 2 ][ 3 ][ 4 ][ 5 ][  ]
[ 6 ][ 7 ][ 8 ][ 9 ][ 0 ][ E ]
```

or

```
[ 1 ][ 2 ][ 3 ][ 4 ][ 5 ][ 6 ][ 7 ][ 8 ][ 9 ][ 0 ]
[ A ][ B ][ C ][ D ][ E ][ F ][ G ][ H ][ I ][ J ]
[ K ][ L ][ M ][ N ][ O ][ P ][ Q ][ R ][ S ][ T ]
[ U ][ V ][ W ][ X ][ Y ][ Z ][ * ][ # ][ < ][ > ]
```

cRelease is a key-release code.

An 8-bit value or character (not necessarily the one in **cPress**) is returned when a key is released.

0 = Unused.

cCntHold is a hold tick.

How long to hold before repeating.

0 = No Repeat.

cSpdLo is a low-speed repeat tick.

How many times to repeat.

0 = None.

cCntLo is a low-speed hold tick.

How long to hold before going to high-speed repeat.

0 = Slow Only.

cSpdHi is a high-speed repeat tick.

How many times to repeat after low-speed repeat.

0 = None.

RETURN VALUE

None.

SEE ALSO

`rn_keyProcess`

```
int rn_keyProcess(int handle, int reserved);
```

Scans and processes keypad data for key assignment, debouncing, press and release, and repeat. This function is able to process a maximum of 64 keys organized as an 8×8 matrix. Key processing will abort if a busy or -1 status byte is detected.

To ensure keypad driver compatibility, the keypad must be installed so that a strobe line or data line starts on J6 pin 1.

PARAMETERS

handle is an address index to device information. Use `rn_device()` or `rn_find()` to establish the handle.

reserved is reserved for future use. Set to 0.

RETURN VALUE

The status byte from the previous command. -1 means that device information indicates the Keypad/Display interface is not connected to the master.

SEE ALSO

`rn_keyConfig`, `rn_keyGet`

```
char rn_keyGet(int handle, int reserved);
```

Get the next keypress.

PARAMETERS

handle is an address index to device information. Use `rn_device()` or `rn_find()` to establish the handle.

reserved is reserved for future use. Set to 0.

RETURN VALUE

The next keypress, or 0 if none

SEE ALSO

`rn_keyProcess`, `rn_keyUnget`

```
void rn_keyUnget(int handle, char cKey,  
int reserved);
```

Pushes the value of **cKey** to the top of the input queue, which is 16 bytes deep.

PARAMETERS

handle is an address index to device information. Use `rn_device()` or `rn_find()` to establish the handle.

cKey is the value to be pushed.

reserved is reserved for future use. Set to 0.

RETURN VALUE

None.

SEE ALSO

`rn_keyProcess`, `rn_keyGet`

6.6.3.4 Display

The functions used to control the character display are contained in the `RNET_LCDIF.LIB` library located in the Dynamic C `RABBITNET` library directory.

```
int rn_dispInit(int handle, int nrows, int ncols);
```

Initializes the display. Specifically, the function call reinitializes the display controller by:

1. sending an 8-bit interface command 3 times to reset,
2. setting the display to 1 or 2 lines or rows,
3. setting 5×7 dots,
4. disabling display shift,
5. setting the display on and cursor off, and
6. clearing the display and putting the cursor in the upper left corner.

Call this function before invoking any display operations. This function may be altered to suit your display type. Remember to check your display specifications to match the connector pinouts.

PARAMETERS

handle is an address index to device information. Use `rn_device()` or `rn_find()` to establish the handle.

nrows is the number of lines or rows in the display (max. 4 rows).

ncols is the number of columns in the display (max. 20 columns).

RETURN VALUE

The status byte from the previous command. -1 means that device information indicates the Keypad/Display interface is not connected to the master.

SEE ALSO

`rn_dispCmd`, `rn_dispClear`

```
int rn_dispBacklight(int handle, int onOff,
    int reserved);
```

Turns the display backlight on or off. This is not supported on some LCDs or vacuum fluorescent displays.

PARAMETERS

handle is an address index to device information. Use `rn_device()` or `rn_find()` to establish the handle.

onOff turns the backlight on or off

1—turn the backlight on

0—turn the backlight off

reserved is reserved for future use. Set to 0.

RETURN VALUE

The status byte from the previous command. -1 means that device information indicates the Keypad/Display interface is not connected to the master.

SEE ALSO

`rn_dispOnoff`

```
int rn_dispOnoff(int handle, int onOff,
    int reserved);
```

Sets the display screen on or off. Data are preserved when the screen is off.

PARAMETERS

handle is an address index to device information. Use `rn_device()` or `rn_find()` to establish the handle.

onOff turns the display screen on or off

1—turn the display screen on

0—turn the display screen off

reserved is reserved for future use. Set to 0.

RETURN VALUE

The status byte from the previous command. -1 means that device information indicates the Keypad/Display interface is not connected to the master.

SEE ALSO

`rn_dispBacklight`, `rn_dispClear`

```
int rn_dispClear(int handle, int reserved);
```

Clears the display and homes cursor to the upper left corner of the display. This function will wait approximately 3 ms for the display to settle.

PARAMETERS

handle is an address index to device information. Use `rn_device()` or `rn_find()` to establish the handle.

reserved is reserved for future use. Set to 0.

RETURN VALUE

The status byte from the previous command. -1 means that device information indicates the Keypad/Display interface is not connected to the master.

SEE ALSO

`rn_dispOnoff`, `rn_dispGoto`, `rn_dispCursor`

```
int rn_dispGoto(int handle, unsigned wX,  
                unsigned wY, int reserved);
```

Positions the cursor.

PARAMETERS

handle is an address index to device information. Use `rn_device()` or `rn_find()` to establish the handle.

wX is the column position—the typical range is 0 to 19, and depends on the actual display type you are using.

wY is the row position—the typical range is 0 to 3, and depends on the actual display type you are using.

reserved is reserved for future use. Set to 0.

RETURN VALUE

The status byte from the previous command. -1 means that device information indicates the Keypad/Display interface is not connected to the master. -2 means that the row or column position is not valid.

SEE ALSO

`rn_dispClear`, `rn_dispCursor`

```
int rn_dispCursor(int handle, unsigned int style,
                 int reserved);
```

Sets cursor type to be on, off, or blinking.

PARAMETERS

handle is an address index to device information. Use `rn_device()` or `rn_find()` to establish the handle.

style is one of the following cursor macros:

`RNDISP_CUROFF`—cursor off

`RNDISP_CURON`—cursor on

`RNDISP_CURBLINKOFF`—cursor blink off

`RNDISP_CURBLINKON`—cursor blink on

reserved is reserved for future use. Set to 0.

RETURN VALUE

The status byte from the previous command. -1 means that device information indicates the Keypad/Display interface is not connected to the master. -2 means that the cursor style is not valid.

SEE ALSO

`rn_dispClear`, `rn_dispGoto`, `rn_dispCmd`

```
int rn_dispPrintf(int handle, int reserved,
                 char *pcFormat, ...);
```

Prints a formatted string to the display, and will line-wrap. The format is similar to that in the `printf()` call.

This function will block approximately 1 ms per character byte. Therefore, the size of the formatted string should be kept to a minimum.

PARAMETERS

handle is an address index to device information. Use `rn_device()` or `rn_find()` to establish the handle.

reserved is reserved for future use. Set to 0.

pcFormat is the formatted output string whose character buffer size should not exceed 128 bytes.

Any other parameters are arguments.

RETURN VALUE

The status byte from the previous command. -1 means that device information indicates the Keypad/Display interface is not connected to the master.

SEE ALSO

`rn_dispPutc`, `rn_dispData`

```
int rn_dispPutc(int handle, char cByte,  
int reserved);
```

Puts a character on the display, and will automatically increment to next cursor position and line-wrap.

PARAMETERS

handle is an address index to device information. Use **rn_device()** or **rn_find()** to establish the handle.

cByte is the character to display.

reserved is reserved for future use. Set to 0.

RETURN VALUE

The status byte from the previous command. -1 means that device information indicates the Keypad/Display interface is not connected to the master.

SEE ALSO

rn_dispPrintf, rn_dispData

```
int rn_dispData(int handle, char cData,  
char msdelay, int reserved);
```

This function is a low-level routine to send a byte to the display data register.

PARAMETERS

handle is an address index to device information. Use **rn_device()** or **rn_find()** to establish the handle.

cData is the character to display.

msdelay is the delay from 0 to 255 ms that is needed between each command; 1 delay of 1 ms is recommended unless otherwise specified.

reserved is reserved for future use. Set to 0.

RETURN VALUE

The status byte from the previous command.

SEE ALSO

rn_dispPutc, rn_dispPrintf, rn_dispCmd

```
int rn_dispCmd(int handle, char cmd, char msdelay,
               int reserved);
```

This function is a low-level routine to send a command to the display control register.

PARAMETERS

handle is an address index to device information. Use `rn_device()` or `rn_find()` to establish the handle.

cmd is the command to send to the display.

msdelay is the delay from 0 to 255 ms that is needed between each command; 1 delay of 1 ms is recommended unless otherwise specified.

reserved is reserved for future use. Set to 0.

RETURN VALUE

The status byte from the previous command.

SEE ALSO

`rn_dispData`

6.6.4 Status Byte

Section 1.3.5 provides information on the status bytes returned by various function calls.

6.7 Specifications

6.8 Electrical and Mechanical Specifications

Figure 48 shows the mechanical dimensions for the RabbitNet Keypad/Display interface.

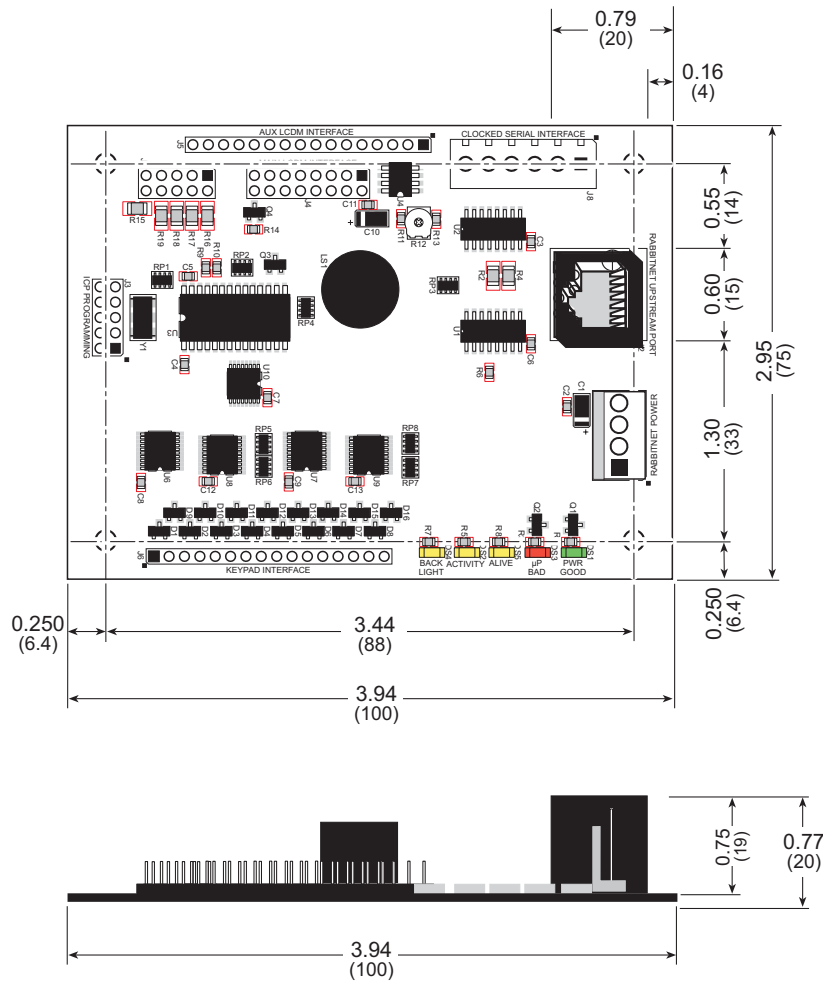

Figure 48. RabbitNet Keypad/Display Interface Dimensions

NOTE: All diagram and graphic measurements are in inches followed by millimeters enclosed in parentheses.

Table 12 lists the electrical, mechanical, and environmental specifications for the RabbitNet Keypad/Display interface.

Table 12. RabbitNet Keypad/Display Interface Specifications

Feature	Specification
Microprocessor	ST72F264G
Keypad	Handles any keypad with up to 16 pins and with up to 64 keys; traces on flex connector tail are at a 0.1" pitch
Display	Accepts one character liquid crystal display from 1 × 8 to 4 × 20 characters with or without backlight using standard 1 × 16 or 2 × 8 connectors with 0.1" pitch, V _{cc} = 5.0 V. Contrast and backlight support are provided.
LEDs	5 hardware- or software-driven: 1 red, 1 green, 3 yellow
RabbitNet™ Serial Port	RS-422 SPI, 1 Mbits/s
Power	V _{cc} : +5 V DC, 60 mA maximum *
Temperature	−40°C to +70°C 0°C to +50°C typ. with customer-supplied LCD
Humidity	5% to 95%, noncondensing
Connectors	IDC connectors: one 1 × 16 header with 0.1" pitch one 1 × 16 socket with 0.1" pitch one 2 × 8 header with 0.1" pitch Friction-lock connectors: one polarized 4-position header with 0.156" pitch One RJ-45 RabbitNet™ jack
Board Size	2.95" × 3.94" × 0.77" (75 mm × 100 mm × 20 mm)

* Current specified does not include current consumed by LCD or backlight.

6.8.1 Physical Mounting

Figure 49 shows position information to assist with interfacing other boards with the Keypad/Display interface.

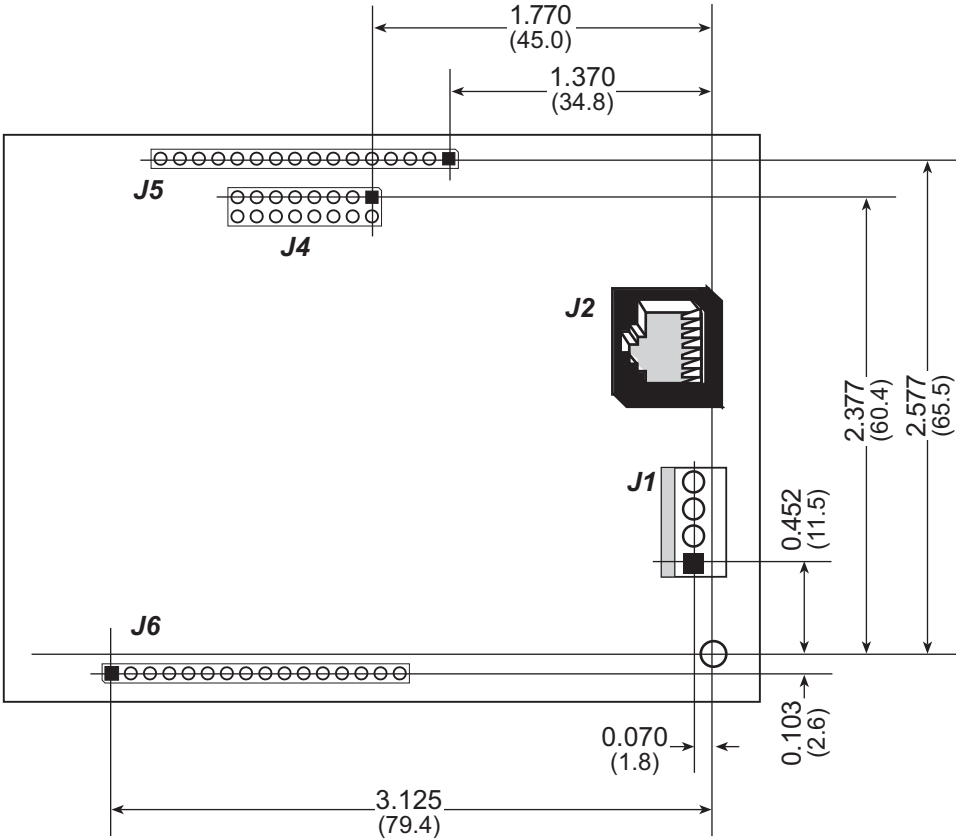

Figure 49. Board Footprint for Keypad/Display Interface

RN1600

APPENDIX A. KEYPAD/DISPLAY INTERFACE EXPANSION KIT

Rabbit Semiconductor offers a Keypad/Display Interface Expansion Kit for that includes a Keypad/Display interface (Part No. 101-0879) and provides the necessary hardware components required to run the sample programs and to demonstrate the functionality of the Keypad/Display interface. Table A-1 lists the items in the Expansion Kit along with their part numbers.

Table A-1. Keypad/Display Interface Card Expansion Kit Parts

Description	Quantity	Supplier	Part Number
Rubber Foot	4	Rabbit Semiconductor	804-0023
4 × 20 Character Display	1	Rabbit Semiconductor	535-0026
2 × 20 Character Display	1	Rabbit Semiconductor	535-0031
3 × 4 Keypad	1	Rabbit Semiconductor	505-0013
2 × 6 Keypad	1	Rabbit Semiconductor	505-0027
10-position Flex Connector for above keypads	2	FCI/Berg	65801-010
4 × 10 Keypad	1	Rabbit Semiconductor	505-0004
13-position Flex Connector for above keypad	1	FCI/Berg	65801-013
2 × 8 IDC Header	2	Pinrex	PH1S-208GB-1160
2 × 8 IDC Socket	2	Pinrex	SBQ-16P-D-100-TG
1 × 16 Male-Male Hi-Rel Pin Strip	1	MilMax	800-10-016-10-0001
1 × 16 Hi-Rel Socket Strip	2	Pinrex	MSS-116SB
6" 2 × 8 F-F IDC Ribbon Cable	1	DigiKey	M3AAA-1606J-ND
1 × 16 Male-Male 4" Flex Strip	1	Amp/Tyco	5-1437145-7
1 × 16 IDC Header	2	Pinrex	PH1S-116GB-1160
0.156" 4-position Friction-Lock Housing	2	Molex	09-50-3041
0.156" Crimp Pins	8	Molex	08-50-0108
0.1" 2-pin Jumper	2	Pinrex	MJ1B-BGB
Straight-Through Ethernet Cable	1	Rabbit Semiconductor	540-0076

Peel off the backing to expose the adhesive on the rubber feet included with the Expansion Kit, and attach the rubber feet to the bottom side of your Keypad/Display interface. The rubber feet will help protect the bottom side of your Keypad/Display interface from abrasion while you run the sample programs and do your application development.

A.1 Keypads

Three keypads are supplied with the Expansion Kit. Each keypad already has its corresponding flex connector installed.

Connect pin 1 of the keypad to pin 1 of the Keypad/Display interface header J6 as shown in Figure A-1. Follow the pin 1 locations as shown in the diagram and disregard the blue dot that may be present on one side of the connector.

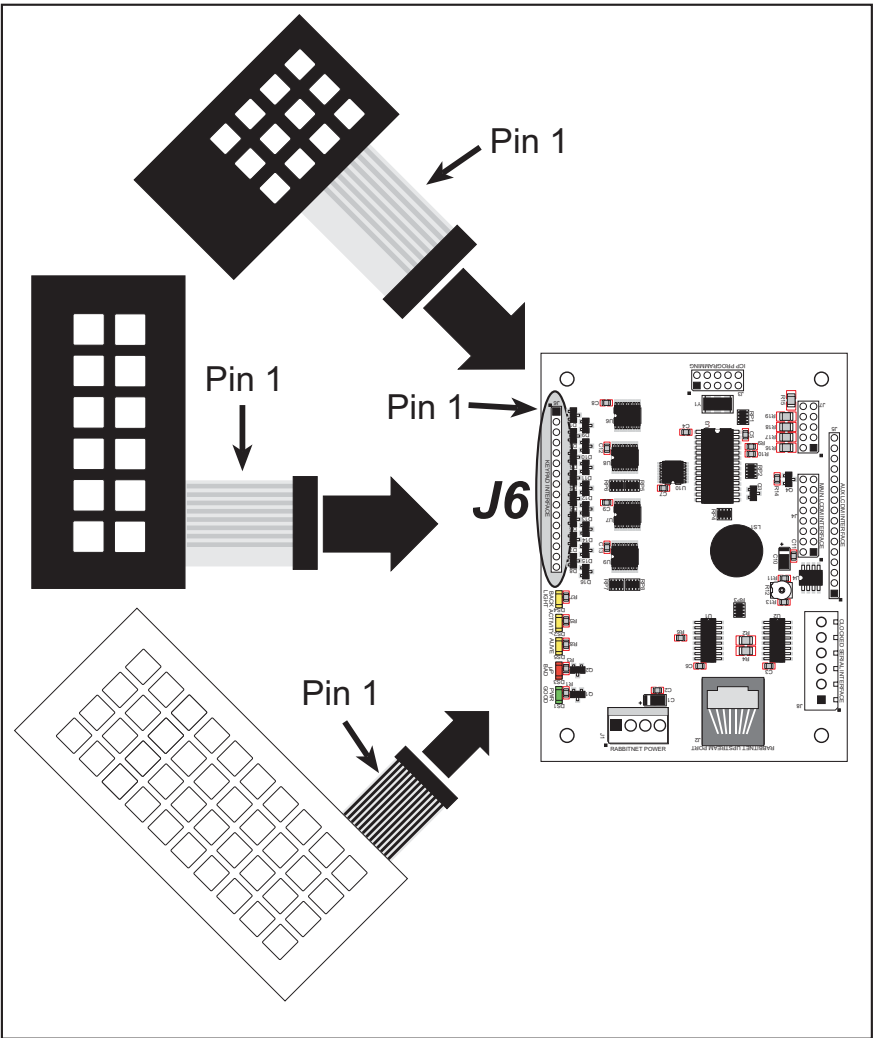

Figure A-1. Connecting Keypads to Keypad/Display Interface Header J6

NOTE: To insure compatibility with the software driver routines, pin 1 on header J6 must always be connected to a keypad strobe or data line; do not leave pin 1 unconnected.

Two of the keypads supplied with the kit use 10-pin connectors, and the third keypad uses a 13-pin connector. Since the Keypad/Display interface can support a keypad with up to 16 lines, some of the connection points on header J6 will remain unused when using the keypads from the Expansion Kit. Flex connectors of this style can be obtained in various widths that will accommodate most keypads with 0.1" trace spacing. The connectors are made by FCI/Berg and are referred to as series 65801 "Clincher." They can be purchased online from [Mouser Electronics](#).

When running one of the sample programs be sure to attach the keypad associated with that sample program.

Table A-2. Keypads Used In Sample Programs

Keypad	Sample Program
3 × 4	PONG . C
2 × 6	ALPHANUM . C
4 × 10	KEYBASIC . C

A.1.1 Keypad Templates

You may wish to print out, then cut and insert the keypad templates into your keypads to facilitate your interactions with the keypad while running the sample programs.

2 × 6 Keypad

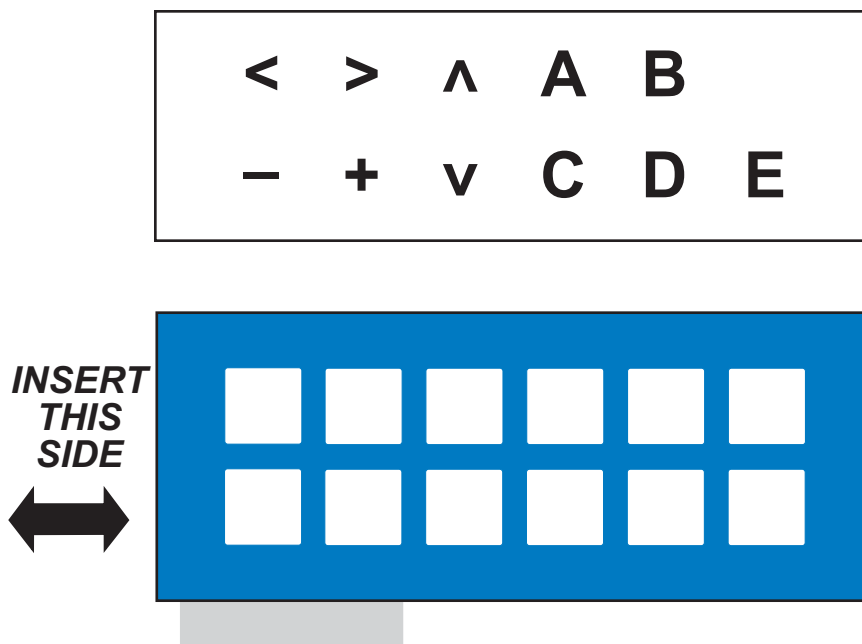

3 x 4 Keypad

1	2	3	+
4	5	6	-
7	8	9	0

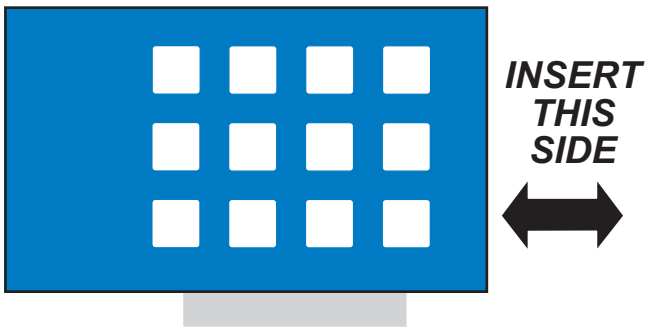

4 x 10 Keypad

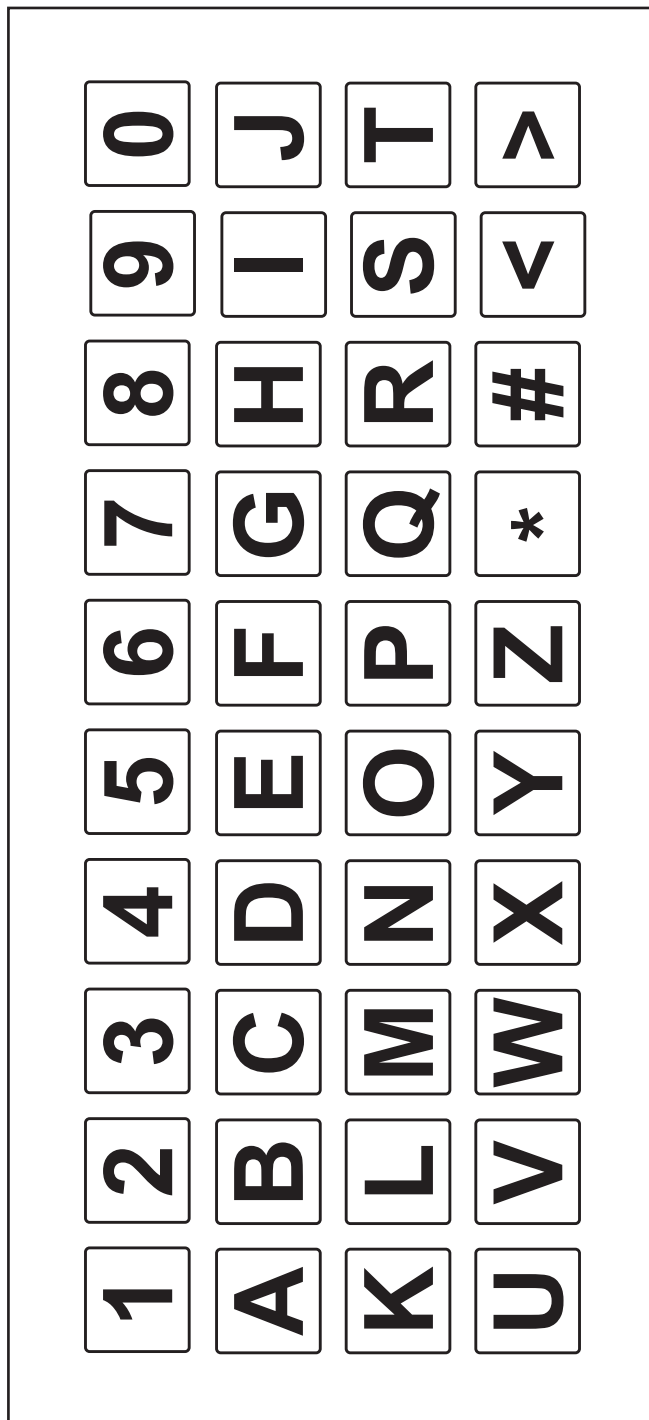

Remove adhesive backing, then stick on character template.

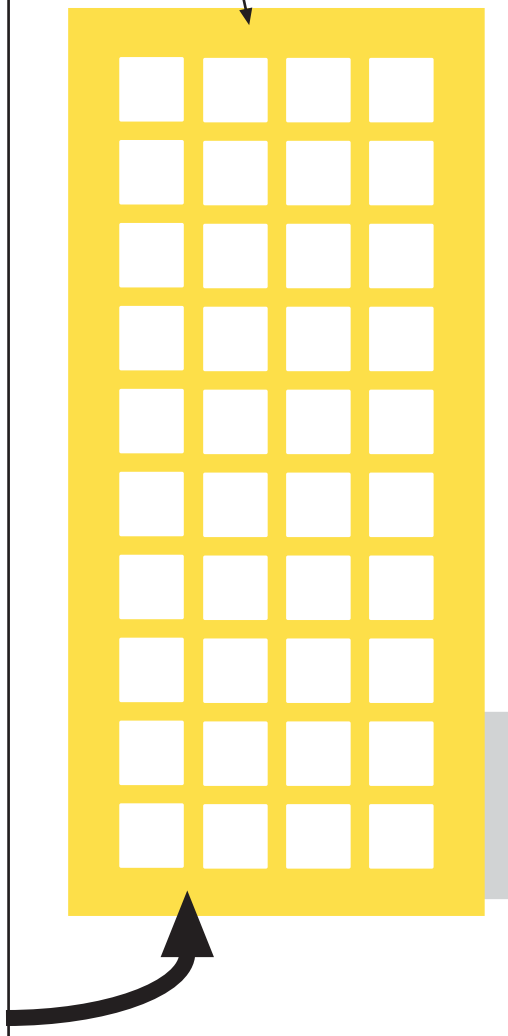

A.2.1 2 × 20 Character LCD

The 2 × 20 display does not have a backlight, so the jumpers on header J7 do not need to be set, and may be left in place as is. This display uses the dual-row 2 × 8 connector. Two ways are available to attach the display to the Keypad/Display interface.

1. To attach the 2 × 20 display directly to the Keypad/Display interface, solder a 2 × 8 socket to the bottom side of the display printed circuit board (the side that does not have the actual display). The display can now be attached to the Keypad/Display interface at header J4. Make sure that pin one on the display is aligned with pin 1 on J4.
2. A 6" flat ribbon cable (included with the Expansion Kit) can also be used to attach the 2 × 20 display. The cable has 2 × 8 female IDC connectors at each end. To use the cable, solder a 2 × 8 header to the top side of the display printed circuit board (the same side that has the actual display). Now you can use the 6" flat ribbon cable to connect the display to header J4 on the Keypad/Display interface, making sure that pin 1 is connected to pin 1 on both sides.

When you port this design to your own use, the ribbon cable can be up to 2 m long.

The `LCDBASIC.C` and `PONG.C` sample programs illustrate the use of the 2 × 20 display.

A.2.2 4 × 20 Character LCD

The 4 × 20 display has an LED backlight, and the factory-default jumpers at J7 are already set to provide the necessary series resistance for the LED backlight. (The factory default is for 2-pin jumpers across pins 3–4, 5–6, and 9–10, which provides a series resistance of 5.0 Ω.)

The 4 × 20 display uses a 1 × 16 in-line connector interface. Three ways are available to attach the display to the Keypad/Display interface.

1. Solder one end of the 1 × 16 male-male 4" flex strip into either the top or bottom side of the LCD display printed circuit board. Press the other end into the socket strip at J5 on the Keypad/Display interface. When installing the flex strip into J5, work from one end towards the other, inserting 3 or 4 pins as you go. The flex strip provides a tight fit to the socket strip. Make sure that pin 1 is connected to pin 1 on both ends of the cable.

When you port this design to your own use, the flex strip can be up to 2 m long.

2. The display can be connected directly to the Keypad/Display interface by first soldering a 1 × 16 Hi-Rel pin strip onto the bottom side of the display printed circuit board (the side that does not have the actual display). The pins on one side of the pin strip have a slightly larger diameter than the pins on the other side. Solder the larger pins into the display. Next press the display with the pin strip installed into J5 on the Keypad/Display interface. Make sure that pin 1 is connected to pin 1 on both sides. The pin strip provides a tight fit. Working from the display side of the display, press directly above the pins while working back and forth across the connector until it is fully seated into J5 on the Keypad/Display interface. The connection was designed to be tighter than normal so the display can stand off the side of the Keypad/Display interface without bending.

The `ALPHANUM.C` sample program illustrates the use of the 4 × 20 character display.

A.3 ZMENU.C

ZMENU.C demonstrates a menu system that allows you to list a set of action options for an operator to choose from. Keypads and character displays included in the Expansion Kit are used with this program. All the parameters required for the menu system can be set dynamically while the sample program is running, and can be changed via the `Zmenu_Config()` function included with the sample program.

The instructions below explain how to set up the hardware and then run **ZMENU.C**.

1. Connect pin 1 of the 2 × 6 keypad to pin 1 of the Keypad/Display interface header J6 as shown in Figure A-1.

The 2 × 6 keypad character assignment is as follows.

```
[ U ][ S ][ L ][ R ][   ][   ]  
[ D ][ P ][ - ][ + ][   ][ E ]
```

where

- U** scrolls up one menu option
- D** scrolls down one menu option
- S** pages up to the next set of menu items
- P** pages down to the next set of menu items
- L**—cursor left, used in the data-entry section to move the cursor to the next character for selection.
- R**—cursor right, used in the data-entry section to move the cursor to the next character for selection.
- delete item, used in the data-entry section to delete the last character selected.
- +**—add item, used in the data-entry section to select the character highlighted.
- E** selects the highlighted item.

A keypad template is provided below for your convenience.

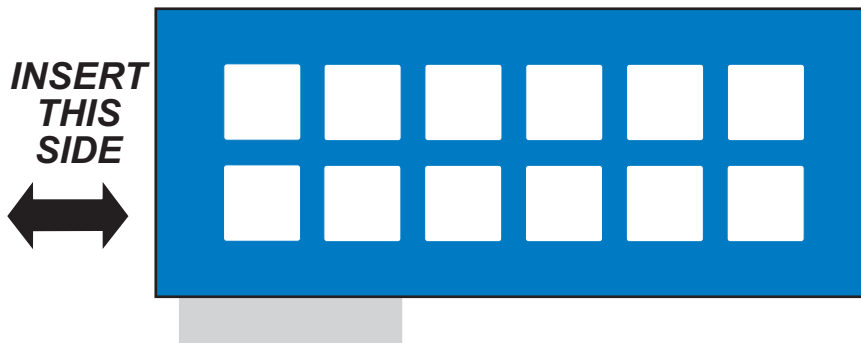
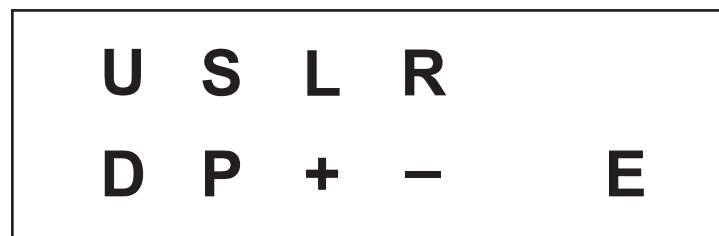

2. Connect the 4×20 display to header J5 on the Keypad/Display interface as shown in Figure A-2.
3. Compile and run **ZMENU.C**.
4. The LCD will display **Menu Title**, followed by user-selectable options. Use the scrolling and paging keys to view all the items in the menu. Choose an item to select, then press the **E[nter]** key to select the item.

This sample program can also be used with a 3×4 keypad (included in the Expansion Kit) and with a 4×6 keypad (*not* included in the Expansion Kit). Uncomment the appropriate **ZMENU_KEYSTROBELINES** macro in the configuration section in the sample program.

Once **ZMENU.C** has compiled, the menu display information can also be viewed via HyperTerminal, Tera Term, or another serial port emulator by moving the programming cable connector on the master single-board computer from **PROG** to **DIAG** and then cycling the power. The HyperTerminal setup is shown here.

The **ZMENU_COLUMNS** and **ZMENU_ROWS** macros are used to define the size of the display, and can be changed in the configuration section in the sample program.

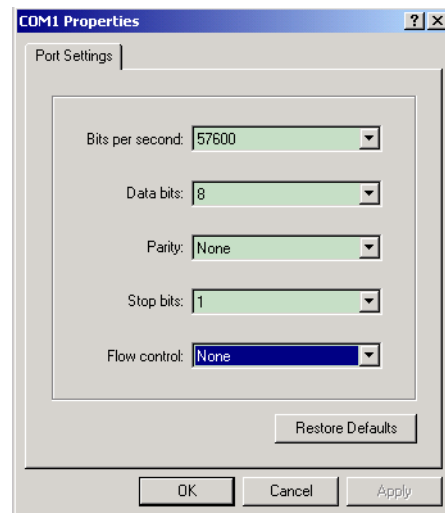

The function `Zmenu_KeyConfig()` is available in the sample program to allow you to lay out your own keypad character assignment.

```
int Zmenu_Config(int MenuNumber, ...);
```

Sets up a menu for use with keypads and character displays. The function uses identifiers to determine the course of action. Each call to `Zmenu_Config()` must incorporate one of the two identifiers, `ZMENU_TITLE` or `ZMENU_OPTION`, and must end with the identifier `ZMENU_END`.

PARAMETERS

`MenuNumber` is the menu number to configure.

The remaining parameters are identifiers and parameters used for the menu.

IDENTIFIER MACROS

`ZMENU_TITLE` identifies the next set of settings to be associated with the menu parameters. A 1 parameter following the identifier is the title of the menu, a 2 parameter specifies the characteristics of the menu. The following characteristics are allowed.

`ZMENU_BORDER` places a border around the menu.

`ZMENU_KEYPAD` uses the keypad to control the menu.

These parameters can be OR'ed together as needed.

A 3 parameter after `ZMENU_TITLE` is a pointer to the font that will be used for the menu and its associated items. `NULL` can be used if the menu is being used on a character-style LCD that has no fonts.

`ZMENU_OPTION` identifies the next set of parameters to be associated with a particular option within the menu. A 1 parameter following the identifier is always the title of the option. A 2 parameter is the item action that will be taken if the item is selected. The parameter following the action parameter depends on the action parameter itself. The following action parameters are allowed.

`ZMENU_FUNCTION`—The next parameter is a pointer to a user-defined function that will be called when the item is selected. The function must return a non-zero when completed, and must be non-blocking.

`ZMENU_SUBMENU`—The next parameter is the menu number to be displayed when the item is selected.

`ZMENU_LASTMENU`—No parameter is entered. The item selected will display the previous menu.

`ZMENU_SET_FLAG`—Two parameters are required. The first parameter is a pointer to an int that this item is associated with; the next parameter is the value to place in that int.

`ZMENU_LONG` is a data-entry function. Two parameters are required. The first parameter is a long pointer to a long value that will be used for data entry. The second parameter is the maximum number of digits that the long value will have (in decimal format) when this item is selected. A data-entry window will be displayed to allow the operator to enter a numeric value.

`ZMENU_FLOAT` is a data-entry function. Two parameters are required. The first parameter is a float pointer to a float value that will be used for data entry. The second parameter is the maximum number of digits that the float value will have (in decimal format) when this item is selected. A data-entry window will be displayed to allow the operator to enter a numeric value.

ZMENU_STRING is a data-entry function. Two parameters are required. The first parameter is a char pointer to a char array value that will be used for data entry. The second parameter is the maximum number of digits that the char array value will have (in decimal format) when this item is selected. A data-entry window will be displayed to allow the operator to enter an alphanumeric value.

ZMENU_TIMEDATE is a data-entry function. The only parameter required is a pointer to the time structure that will be used for the data entry. When this item is selected, a data-entry window will be displayed to allow the operator to enter a time/date value.

ZMENU_PASSWORD can be OR'ed with the above data-entry functions to enable password protection.

EXAMPLE

```
int Zmenu_Config(0, ZMENU_TITLE,"MAIN MENU", ZMENU_KEYPAD | ZMENU_BORDER,  
NULL, 20,4,0,0,3, ZMENU_ITEM,"Toggle Backlight", ZMENU_FUNCTION,zbacklight,  
ZMENU_ITEM,"Increment LEDs", ZMENU_SET_INT,&ledState,1,  
ZMENU_ITEM,"Turn Off LEDs", ZMENU_SET_INT,&ledState,0,  
ZMENU_ITEM,"GOTO DATA MENU",ZMENU_SUBMENU,1,  
ZMENU_ITEM,"GOTO LOG MENU",ZMENU_SUBMENU,2, ZMENU_END);
```

A.4 Configuring Key Code Indexes and Physical Keypad Arrangement

The keypads supplied in the Expansion Kit and the sample programs use a keypad driver scheme that has an 8×8 matrix array with a maximum of 8 strobe pins. This allows a maximum of 64 keys in a keypad.

There is no standard keypad layout, and you should check the manufacturer's specifications for the physical key arrangement and for the strobe and data lines. Regardless of the keypad you chose, **a data or strobe pin must be connected to J6 pin 1** of the Keypad/Display interface connector for the keypad drivers to work properly. The examples in this section explain how to assign key code indexes for the keypads supplied in the Expansion Kit.

A.4.1 Basics of Assigning Key Code Indexes

The sample programs have already set up the key code index assignments and character keypresses for the keypads supplied in the Expansion Kit. The `cRaw` key code index in the `rn_keyConfig()` function does this for you.

The key code index parameter which is explained further in this section. First, let's look at some basics.

The keypad interface connector contains 16 pins, which you configure as *strobe pins and data pins* using the `rn_keyInit()` function.

15	14	13	12	11	10	9	8	7	6	5	4	3	2	1	0
----	----	----	----	----	----	---	---	---	---	---	---	---	---	---	---

Keypad drivers follow a scheme that assigns *key code indexes* in a 8×8 matrix array. The table below shows a representation of the array with the key code index ranging from 0 to 63 in an 8×8 matrix.

63	62	61	60	59	58	57	56
55	54	53	52	51	50	49	48
47	46	45	44	43	42	41	40
39	38	37	36	35	34	33	32
31	30	29	28	27	26	25	24
23	22	21	20	19	18	17	16
15	14	13	12	11	10	9	8
7	6	5	4	3	2	1	0

Combining the two tables, our indexing table might look like this.

									63	62	61	60	59	58	57	56
									55	54	53	52	51	50	49	48
									47	46	45	44	43	42	41	40
									39	38	37	36	35	34	33	32
								■	31	30	29	28	27	26	25	24
								■	23	22	21	20	19	18	17	16
									■	14	13	12	11	10	9	8
									7	■	5	4	3	2	1	0
15	14	13	12	11	10	9	8	7	6	5	4	3	2	1	0	

The shaded blocks describe how key code indexes are arrived at using strobe and data pins in a 4 × 6 arrangement of keys.

Physical Connections

Pins 15 through 10 are shown, but are unused.

Pins 9, 8, 7 and 6 are strobe pins.

Pins 5 through 0 are data pins.

Assigning Key Code Indexes

Data pins 5 through 0 determine the key code indexes (shaded area):

Pin 0 is networked to 0, 8, 16, 24.

Pin 1 is networked to 1, 9, 17, 25.

Pin 2 is networked to 2, 10, 18, 26.

Pin 3 is networked to 3, 11, 19, 27.

Pin 4 is networked to 4, 12, 20, 28.

Pin 5 is networked to 5, 13, 21, 29.

Strobe pins 9 through 6 strobe the key code indexes (black blocks):

Pin 9 strobos key indexes 29 through 24.

Pin 8 strobos key indexes 21 through 16.

Pin 7 strobos key indexes 13 through 8.

Pin 6 strobos key indexes 5 through 0.

The remaining pins and indexes are unused.

A.4.2 Expansion Kit Keypads

A.4.2.1 3 × 4 Keypad

The physical arrangement of the keys has the 3 × 4 arrangement of key code indexing as shown in the shaded area below.

63	62	61	60	59	58	57	56
55	54	53	52	51	50	49	48
47	46	45	44	43	42	41	40
39	38	37	36	35	34	33	32
31	30	29	28	27	26	25	24
23		21	20	19	18	17	16
15	14		12	11	10	9	8
7	6	5		3	2	1	0
7	6	5	4	3	2	1	0

Physical Connections

Pins 15 through 8 are not shown, and are unused.

Pins 6, 5, 4 are strobe pins, and pins 3 through 0 are data pins.

Key Code Indexes

Data pins 3 through 0 determine the key code indexes—19, 18, 17, 16; 11, 10, 9, 8; 3, 2, 1, 0.

Pin 6 strobos key code indexes 19, 18, 17, 16.

Pin 5 strobos key code indexes 11, 10, 9, 8.

Pin 4 strobos key code indexes 3, 2, 1, 0.

The remaining pins and indexes are unused.

A.4.2.2 2 × 6 Keypad

The physical arrangement of the keys has the 2 × 6 arrangement of key coding indexing as shown in the shaded area below.

63	62	61	60	59	58	57	56
55	54	53	52	51	50	49	48
47	46	45	44	43	42	41	40
39	38	37	36	35	34	33	32
31	30	29	28	27	26	25	24
23	22	21	20	19	18	17	16
	14	13	12	11	10	9	8
7		5	4	3	2	1	0
7	6	5	4	3	2	1	0

Physical Connections

Pins 15 through 8 are not shown, and are unused.

Pins 7, 6 are strobe pins, and pins 5 through 0 are data pins.

Key Code Indexes

Data pins 5 through 0 determines the key code indexes—13, 12, 11, 10, 9, 8; 5, 4, 3, 2, 1, 0.

Pin 7 strobes key code indexes 13, 12, 11, 10, 9, 8.

Pin 6 strobes key code indexes 5, 4, 3, 2, 1, 0.

The remaining pins and indexes are unused.

A.4.2.3 4 × 10 Keypad

The physical arrangement of the keys has a *different* arrangement of key code indexing. Because of the manufacturer's design, the physical arrangement of key indexes will have the following arrangement.

32	33	24	25	16	17	8	9	0	1
34	35	26	27	18	19	10	11	2	3
36	39	28	31	20	23	12	15	4	7
38	37	30	29	22	21	14	13	6	5

The 4 × 10 key code indexing is still derived in the same way as the other two keypads. Although the diagram below appears to be a 5 × 8 keypad arrangement, note that the strobe pins still strobe the same key code indexes as in the 4 × 10 arrangement above.

					63	62	61	60	59	58	57	56
					55	54	53	52	51	50	49	48
					47	46	45	44	43	42	41	40
					39	38	37	36	35	34	33	32
					31	30	29	28	27	26	25	24
					23	22	21	20	19	18	17	16
					15	14	13	12	11	10	9	8
					7	6	5	4	3	2	1	0
12	11	10	9	8	7	6	5	4	3	2	1	0

Physical Connections

Pins 15 through 13 are not shown, and are unused.

Pins 12, 11, 10, 9, 8 are strobe pins, and pins 7 through 0 are data pins.

Key Code Indexes

Data pins 7 through 0 determines the key code indexes—39 through 0.

Pin 12 strobes key code indexes 39 through 32.

Pin 11 strobes key code indexes 31 through 24.

Pin 10 strobes key code indexes 23 through 16.

Pin 9 strobes key code indexes 15 through 8.

Pin 8 strobes key code indexes 7 through 0.

The remaining pins and indexes are unused.

A.5 2 × 6 Keypad Datasheet

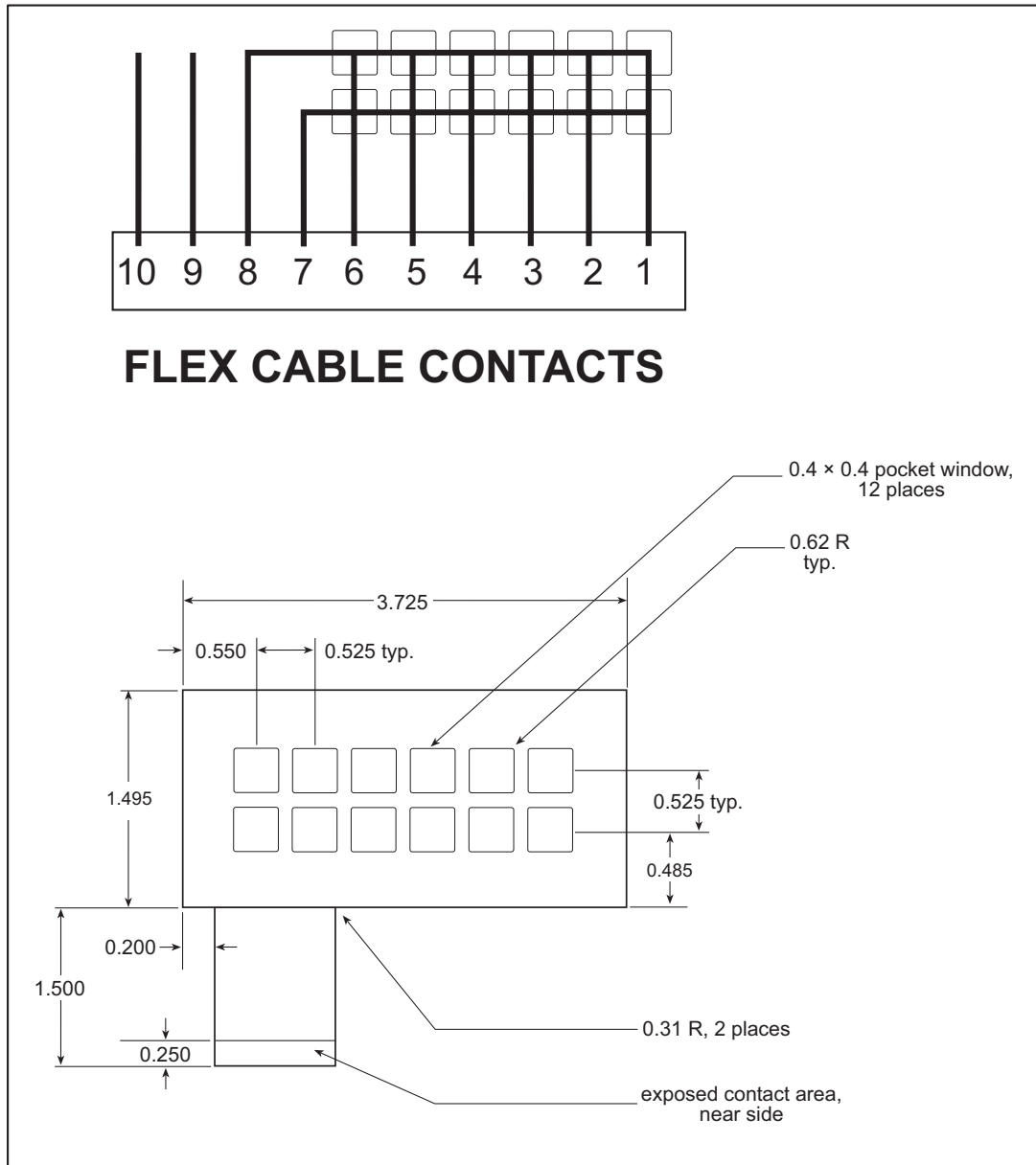

A.6 3 × 4 Keypad Datasheet

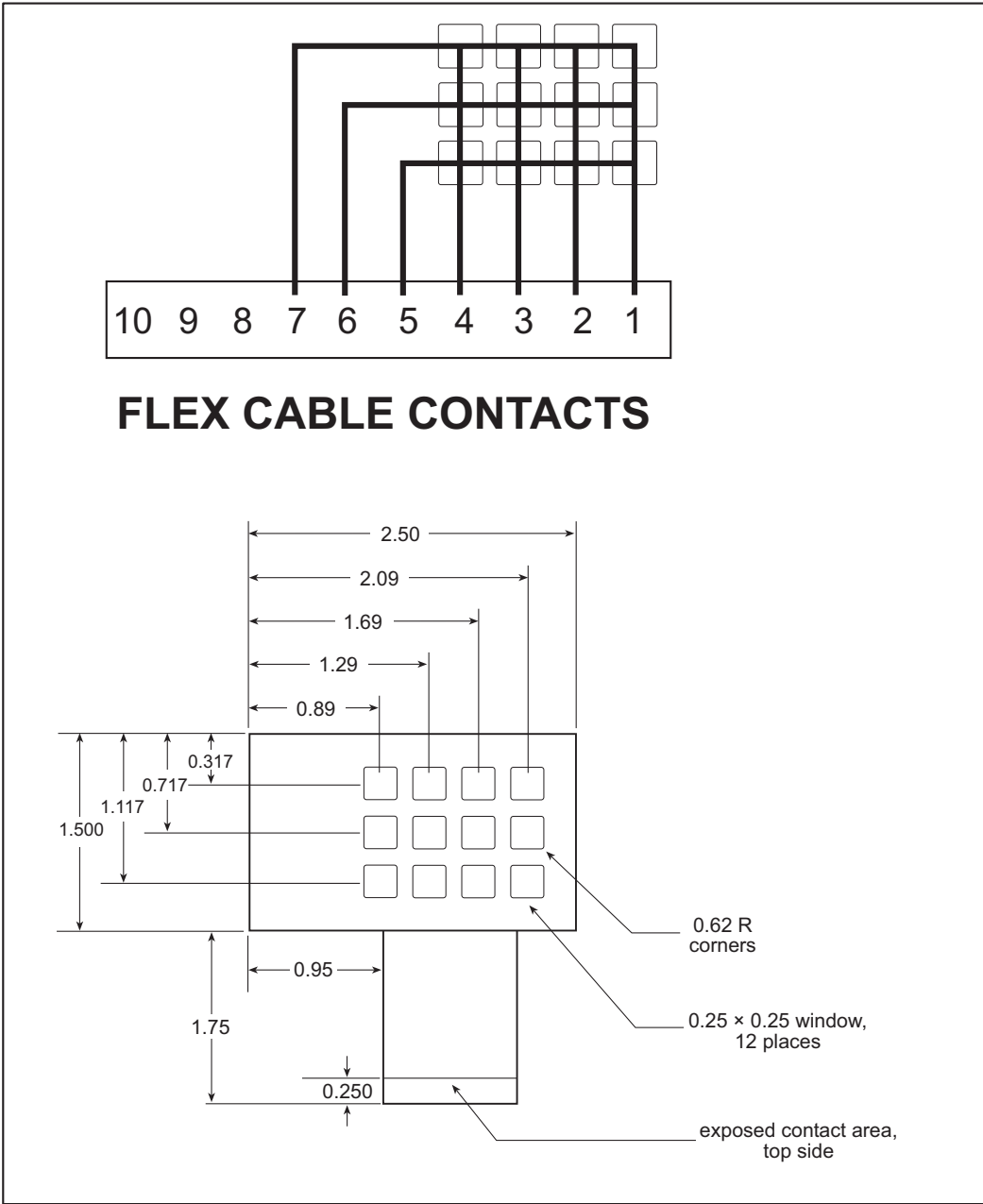

RN1600

A.7 4 x 10 Keypad Datasheet

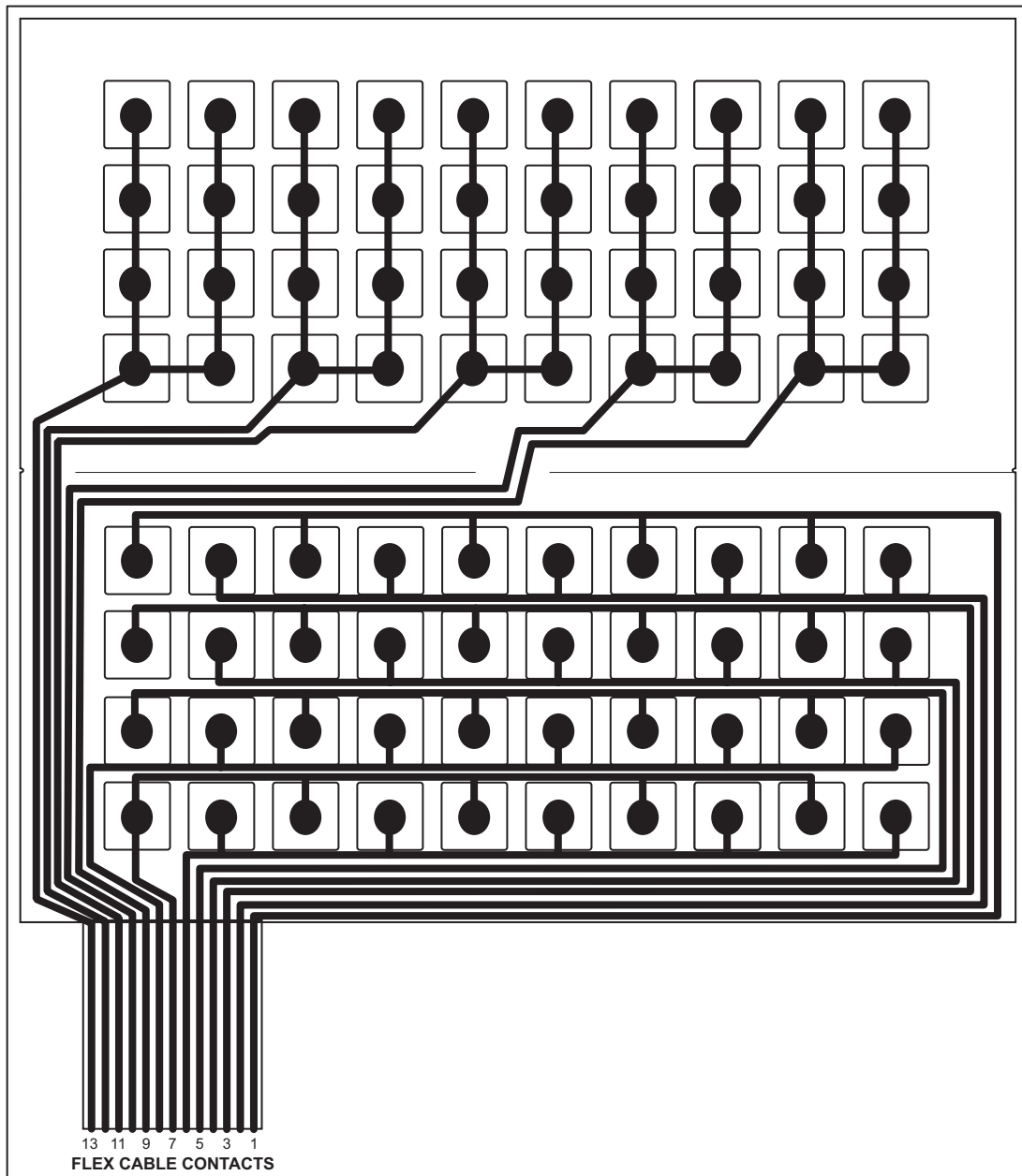

KDIF

A.8 2 × 20 Character LCD Datasheet



SPECIFICATIONS FOR LCD MODULE

CUSTOMER	STD
MODEL	WM-C2002M-1GLYd VER. 7
CUSTOMER APPROVED	

APPROVED BY	CHECKED BY	ORGANIZED BY

APPROVAL FOR SPECIFICATIONS ONLY

APPROVAL FOR SPECIFICATIONS AND SAMPLE

台中縣潭子鄉 427 台中加工出口區建國路 9 號之 2
9-2, CHIEN-KUO RD., TEPZ TANTZU, TAICHUNG 427, TAIWAN, R.O.C.
TEL: 886-4-25347288, FAX: 886-4-25310868

History of Version

Version	Chap.	Contents	Date	Note
d1	-	New Version	06.May.1996	SPEC.
d2	-	Change as follow by: Wintek 1.Modified Spec. Style	20.Aug.1996	SPEC. & Sample
d3	-	Change as follow by: Wintek 1.Modified Spec. Style	30.Nov.1996	SPEC. & Sample
d4	Contents 1.1 1.2 1.5	Change as follow by: Wintek 1.Modified IC: KS0066UP-00CC→ST7066-0A	13.Jul.2000	SPEC. & Sample
d5	Contents 1.1 1.2 1.5	Change as follow by: Wintek 1.Modified IC: ST7066-0A→KS0066UP-00CC	15.Jan.2001	SPEC. & Sample
d6	Contents 1.1 1.2 1.5	Change as follow by: Wintek 1.Modified IC: KS0066UP-00CC→ST7066U-0A	28.Apr.2001	SPEC. & Sample
d7	-	Change as follow by: Wintek 1.Modify Spec. Style	16.Oct.2001	SPEC. & Sample

(1) Electronic Units

1.1 Absolute Maximum Ratings

ITEM	SYMBOL	MIN.	TYP.	MAX.	UNIT
OPERATING TEMPERATURE	T_{OP}	0	-	+50	°C
STORAGE TEMPERATURE	T_{ST}	-20	-	+70	°C
INPUT VOLTAGE	V_I	-0.3	-	$V_{DD}+0.3$	V
SUPPLY VOLTAGE FOR LOGIC	$V_{DD}-V_{SS}$	-0.3	-	+7.0	V
SUPPLY VOLTAGE FOR LCD	$V_{DD}-V_0$	-0.3	-	10	V
STATIC ELECTRICITY	Be sure that you are grounded when handling LCM.				

1.2 Electrical Characteristics($T_a = 25\text{ }^\circ\text{C}$, $V_{DD} = 4.5\text{ V}-5.5\text{ V}$)

ITEM	SYMBOL	CONDITION	MIN.	TYP.	MAX.	UNIT
SUPPLY VOLTAGE FOR LOGIC	$V_{DD}-V_{SS}$	$T_a = 25\text{ }^\circ\text{C}$	4.75	5.0	5.25	V
SUPPLY VOLTAGE FOR LCD	$V_{DD}-V_0$ (V_{LCD})	$T_a = 25\text{ }^\circ\text{C}$	-	4.5	-	V
INPUT HIGH VOL	V_{IH}	$T_a = 25\text{ }^\circ\text{C}$	$0.7V_{DD}$	-	V_{DD}	V
INPUT LOW VOL	V_{IL}	$T_a = 25\text{ }^\circ\text{C}$	-	-	$0.2V_{DD}$	V
OUTPUT HIGH VOL	V_{OH}	$T_a = 25\text{ }^\circ\text{C}$	$0.9V_{DD}$	-	V_{DD}	V
OUTPUT LOW VOL	V_{OL}	$T_a = 25\text{ }^\circ\text{C}$	-	-	$0.1V_{DD}$	V
SUPPLY CURRENT FOR LOGIC	I_{DD}	$V_{DD}=5\text{ V}$	-	2.0	-	mA
USED IC	ST7066U-0A&ST7063					

* I_{DD} Measurement condition is for all pixels on display

1.3 Interface Pin Function

JP1:

NO	SYMBOL	I / O	FUNCTION
1.	V _{SS}	P	POWER SUPPLY FOR LOGIC (0V)
2.	V _{DD}	P	POWER SUPPLY FOR LOGIC (+5V ±5%)
3.	V _O	P	CONTRAST ADJUSTMENT
4.	RS	I	REGISTER SELECT SIGNAL
5.	R/W	I	READ / WRITE SELECTION
6.	E	I	ENABLE SIGNAL
7.	DB0	I/O	DATA BUS
8.	DB1	I/O	
9.	DB2	I/O	
10.	DB3	I/O	
11.	DB4	I/O	
12.	DB5	I/O	
13.	DB6	I/O	
14.	DB7	I/O	
15.	N.C.	-	NO CONNECTION
16.	N.C.	-	NO CONNECTION

JP2:

1.	LED+	P	POWER SUPPLY FOR LED (+4.2V)
2.	LEDA	-	CONNECTED TO LED
3.	LEDK	-	CONNECTED TO LED
4.	LED-	P	POWER SUPPLY FOR LED (0V)

1.4 Power Supply for LCD Module

1.Signal Supply Voltage Types

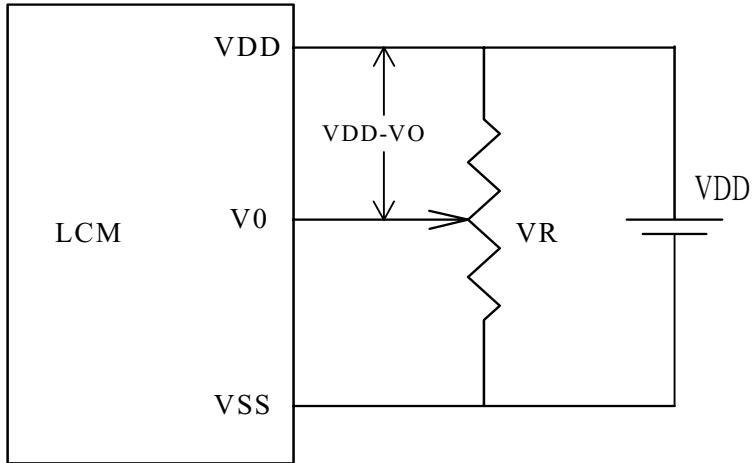

$V_{DD}-V_O$: LCD Driving Voltage
 $V_R=10k\sim 20k$

2. Dual Supply Voltage Types

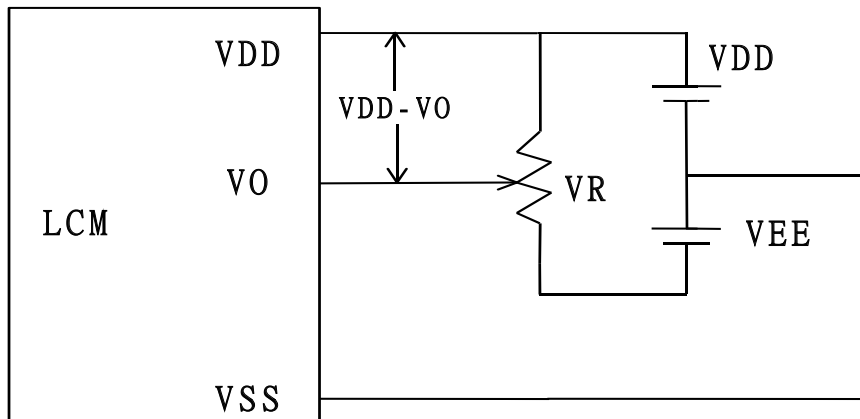

$V_{DD}-V_O$: LCD Driving Voltage
 $V_R=10k\sim 20k$

1.5 Block Diagram with Display RAM Address and Initialization Table

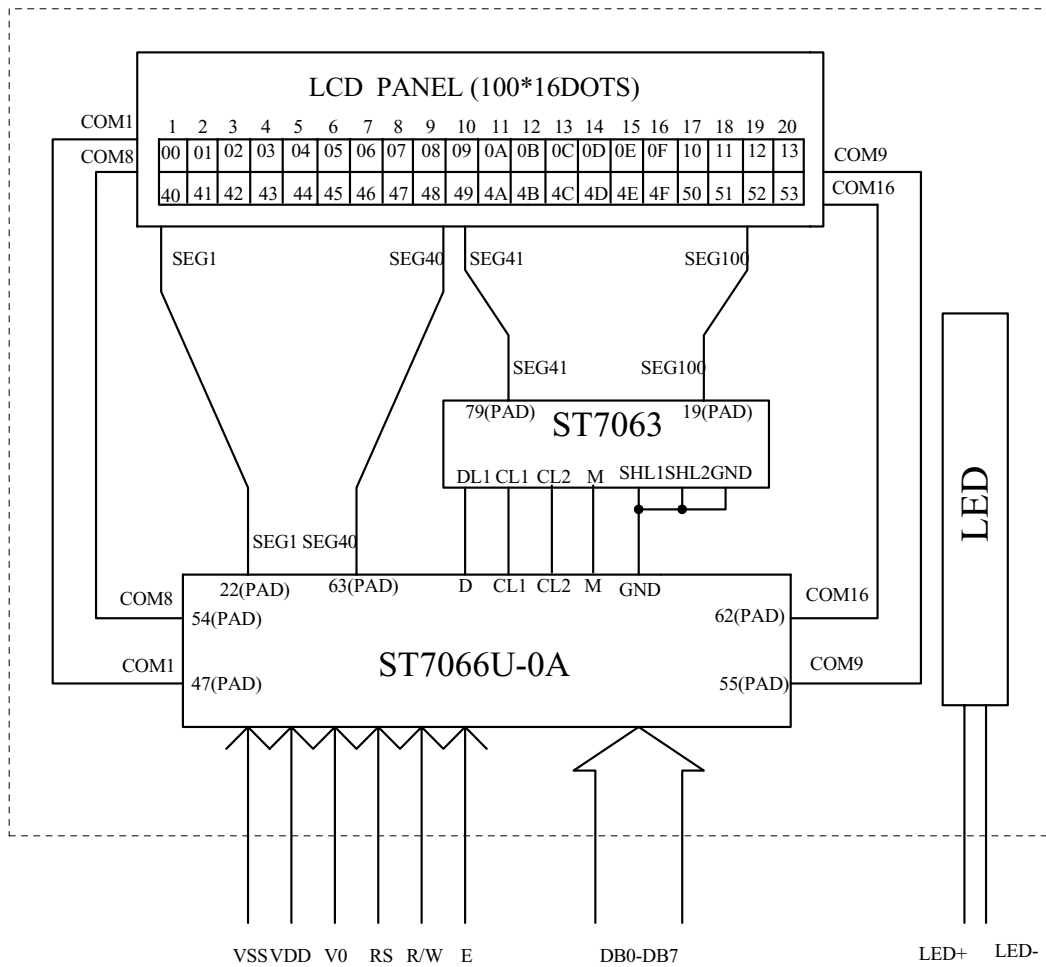

Relation between DD RAM addresses and positions on the are shown above.

The DD RAM address(ADD) is set in the address counter(AC) and is represented in hexadecimal.

Initialization Table:

Instruction	Setting Command	Description
Function Set	00111***	Duty=1/16,8-bit mode,2-line display, 5x8 dots format display mode

1.6 CGROM Map

NO.7066-0A

b7-b4 b3-b0	0000	0001	0010	0011	0100	0101	0110	0111	1000	1001	1010	1011	1100	1101	1110	1111
0000	CG RAM (1)			0	1	P	^	P				-	9	3	0	p
0001	(2)		!	1	A	Q	a	9			.	7	7	4	3	q
0010	(3)		"	2	B	R	b	r			!	イ	ウ	×	β	θ
0011	(4)		#	3	C	S	c	s			!	ウ	フ	ε	ε	*
0100	(5)		\$	4	D	T	d	t			!	I	ト	ト	μ	σ
0101	(6)		%	5	E	U	e	u			.	!	!	!	!	!
0110	(7)		&	6	F	V	f	v			!	!	!	!	!	!
0111	(8)		'	7	G	W	g	w			!	!	!	!	!	!
1000	(1)		<	8	H	X	h	x			!	!	!	!	!	!
1001	(2)		>	9	I	Y	i	y			!	!	!	!	!	!
1010	(3)		*	:	J	Z	j	z			!	!	!	!	!	!
1011	(4)		+	:	K	C	k	c			!	!	!	!	!	!
1100	(5)		,	<	L	!	!	!			!	!	!	!	!	!
1101	(6)		-	=	M	!	!	!			!	!	!	!	!	!
1110	(7)		.	>	N	^	n	^			!	!	!	!	!	!
1111	(8)		/	?	O	L	o	←			!	!	!	!	!	!

(2) Electro-optical Units

2.1 Electro-optical Characteristics

ITEM	SYMBOL	CONDITION	MIN.	TYP.	MAX.	UNIT
VIEW ANGLE (V)	θ	$CR \geq 2$	-40	-	+40	deg.
VIEW ANGLE (H)	ϕ	$CR \geq 2$	-40	-	+40	deg.
CONTRAST RATIO	CR	Ta=25°C	-	5	-	-
RESPONSE TIME	tr	Ta=25°C	-	200	300	ms
RESPONSE TIME	td	Ta=25°C	-	200	300	ms
OPERATING VOLTAGE FOR LCD	V _{LCD}	Ta=0°C	-	4.8	-	V
		Ta=25°C	-	4.5	-	
		Ta=50°C	-	4.2	-	
DRIVE METHOD	DUTY	1/16				
	BIAS	1/5				
LCD TYPE	STN-Gray (Positive / Transflective)					
VIEWING DIRECTION	6 O'CLOCK					

2.2 Optical Definitions

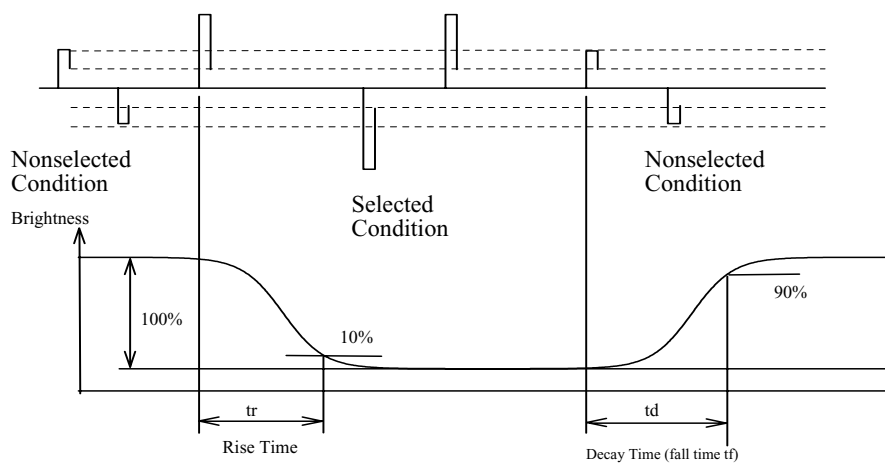

Response Time

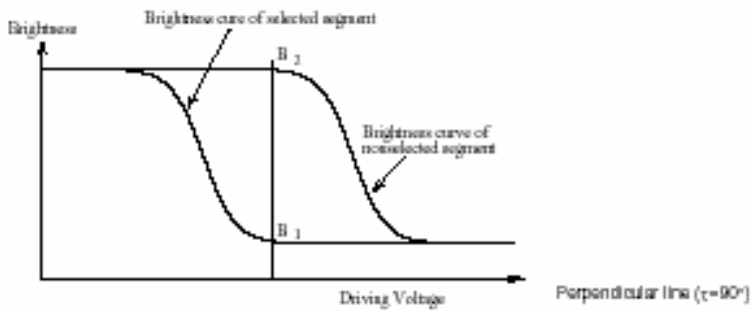
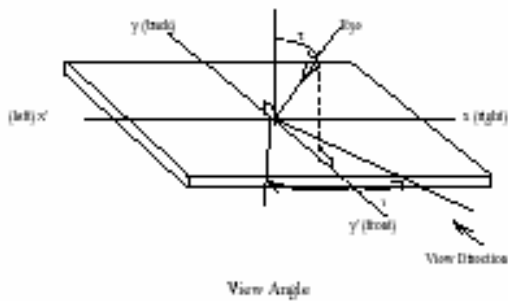
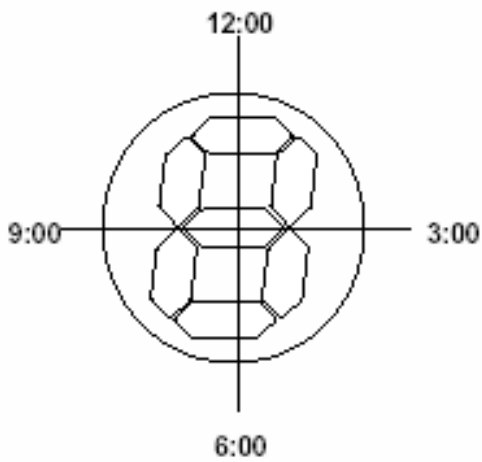

$$\text{Contrast ratio} = \frac{\text{Brightness at nonselected segment (B}_2\text{)}}{\text{Brightness at selected segment (B}_1\text{)}}$$

Contrast ratio (CR)

(3) Mechanical Units

3.1 Mechanical Specification

ITEM	STANDARD VALUE	UNIT
NUMBER OF DOTS	20 CHARACTERS × 2 LINES	-
CHARACTER FORMAT	5 × 8 DOTS	-
MODULE DIMENSION	116.0 (W) ∅ 37.0 (H) ∅ 14.5 MAX.(T)	mm
VIEW AREA	84.0 (W) ∅ 18.6 (H)	mm
ACTIVE AREA	73.5 (W) ∅ 11.5 (H)	mm
CHARACTER SIZE	3.20 (W) ∅ 5.55 (H)	mm
CHARACTER PITCH	3.70 (W) ∅ 5.95 (H)	mm
DOT SIZE	0.60 (W) ∅ 0.65 (H)	mm
DOT PITCH	0.65 (W) ∅ 0.70 (H)	mm
APPROX. WEIGHT	54	g
BACK LIGHT	LED (YELLOW-GREEN)	

SCALE	UNIT	PROJECTION
	mm	 (3)

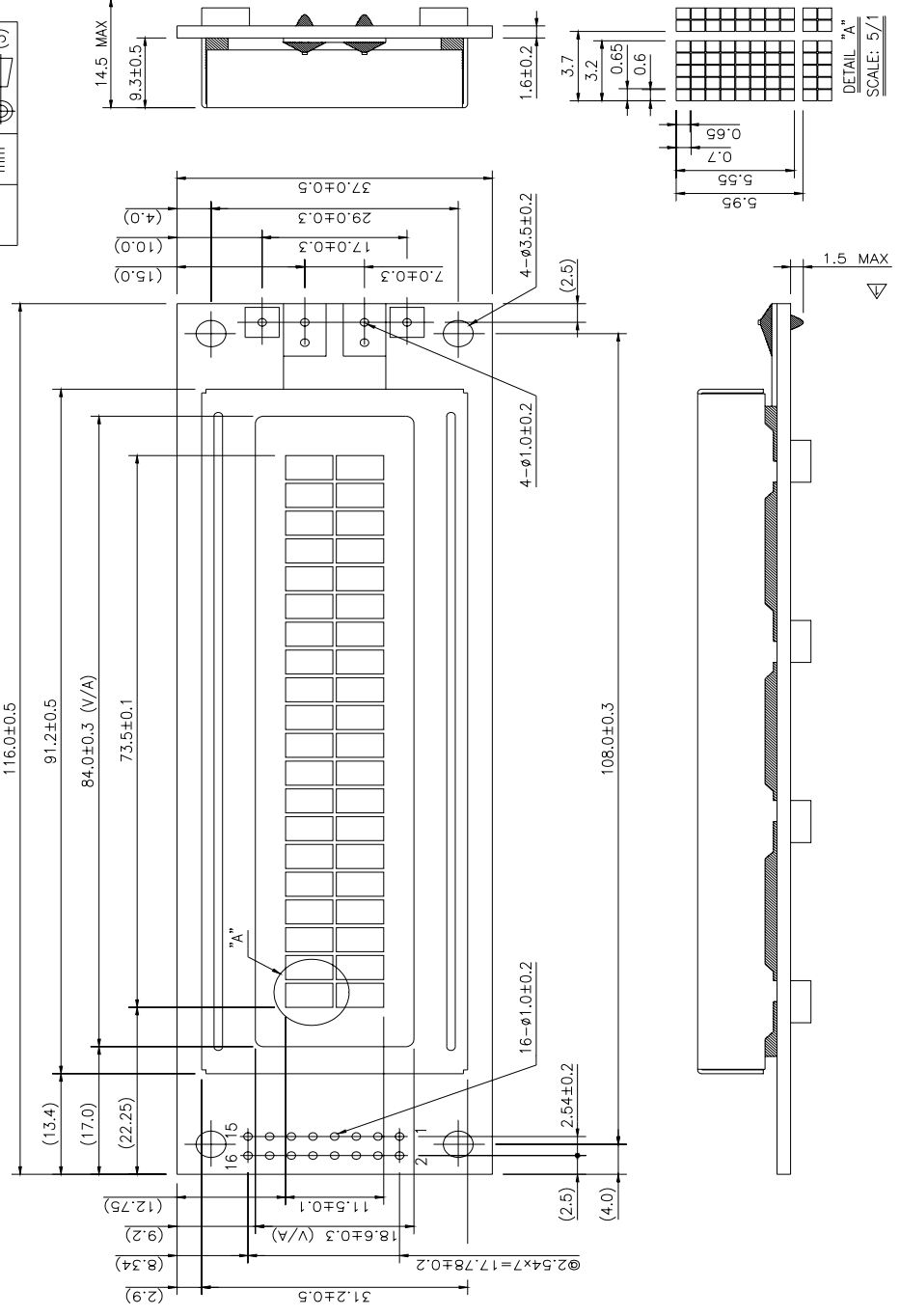

WM-C2002M-1GLYd

3.3 Backlight Specification

1. LED Backlight Styles (Bottom Type):

The LED chips are distributed over the whole light area of the illumination unit, which gives the most uniform light.

2. Data About LED Backlight :

PARAMETER	SYMBOL	MIN.	TYP.	MAX.	UNIT	TEST CONDITION	NOTE
Supply Current	I	-	750	1050	mA	V = 4.2 V	-
Supply Voltage	V	-	4.2	4.6	V	-	-
Reverse Voltage	V _R	-	-	10	V	-	-
Luminous Intensity	I _V	60	-	-	cd/m ²	V = 4.2 V	1,2
Luminous Intensity Uniformity	-	-	-	50	%	V = 4.2 V	3
Peak Emission Wavelength	op	-	572	-	nm	V = 4.2 V	-
Life Time	-	-	20000	-	Hr.	V ≤ 4.6 V	-
Color	Yellow - Green						

NOTE :

1. Backlight Only

2. Average Luminous Intensity Of P1 - P5

3. Luminous Intensity Uniformity = $\frac{\text{MAX} - \text{MIN}}{\text{MAX}} \times 100\%$

3 : MEASURED METHOD :

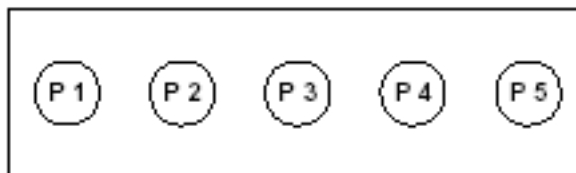

(Effective spatial Distribution)

Hole Diameter ≥ 1.0; 1 to 5 per Position Measured Luminous Intensity

3.4 Packing Method

1. Packaging Material : (per carton)					
NO	Item	Model	Dimensions (mm)	Unit Weight (Kg)	Quantity
1	LCM Module	WM-C2002M-1GLYd	116.0*37.0	0.054	240
2	Tray	V146	PETA	320*217	0.06
3	Product Box	C01	320*219*70	0.131	10
4	Carton	C61	475*345*389	1.208	1
5	Package Bag	C5	467*321*0.08	0.023	10
6	Total Weight	17.9	Kg±5%		

2. Packaging Specifications and Quantity :					
(1) LCM quantity per tray : no per row	2	x no per column	4	=	8
(2) LCM quantity per box : no of trays	8	x quantity per tray	3	=	24
(3) Total LCM quantity in carton : no of boxes	24	x quantity per box	10	=	240

Use empty tray

Put products into the tray

Tray stacking

Rotate tray 180 degrees and place on top of stack. Check the tray stack using Fig. B.

Use package bag

Scotch tape

QC inspection label

The tape to seal carton

Carton label

3. Label Specifications :		Remark
<p>(1) QC Inspection Label</p> <p>Label Color----Green</p>		
<p>(2) Carton Label</p> <p>Label Color----White</p>		

4.1 Specification of Quality Assurance

1. Purpose

This standard for Quality Assurance should affirm the quality of LCD module products to supply to purchaser by WINTEK CORPORATION (Supplier).

2. Standard for Quality Test

2.1 Inspection :

Before delivering, the supplier should take the following tests, and affirm the quality of product.

2.2 Electro-Optical Characteristics:

According to the individual specification to test the product.

2.3 Test of Appearance Characteristics:

According to the individual specification to test the product.

2.4 Test of Reliability Characteristics:

According to the definition of reliability on the specification for testing products.

2.5 Delivery Test:

Before delivering, the supplier should take the delivery test.

2.5.1 Test method: According to MIL-STD-105E, General Inspection Level II take a single time.

2.5.2 The defects classify of AQL as following:

Major defect: AQL=0.65

Minor defect: AQL=2.5

Total defects: AQL=2.5

3. Nonconforming Analysis & Deal With Manners

3.1 Nonconforming analysis:

3.1.1 Purchaser should supply the detail data of non-conforming sample and the non-suitable state.

3.1.2 After accepting the detail data from purchaser, the analysis of nonconforming should be finished in two weeks.

3.1.3 If supplier can not finish analysis on time, must announce purchaser before two weeks.

3.2 Disposition of nonconforming:

3.2.1 If find any product defect of supplier during assembly time, supplier must change the good product for every defect after recognition.

3.2.2 Both supplier and customer should analyze the reason and discuss the disposition of nonconforming when the reason of nonconforming is not sure.

4. Agreement items

Both sides should discuss together when the following problems happen.

- 4.1 There is any problem of standard of quality assurance, and both sides think that it must be modified.
- 4.2 There is any argument item which does not record in the standard of quality assurance.
- 4.3 Any other special problem.

5. Standard of The Product Appearance Test

5.1 Manner of appearance test:

- 5.1.1 The test must be under 20W x 2 or 40W fluorescent light, and the distance of view must be at 30 cm.
- 5.1.2 When test the model of transmissive product must add the reflective plate.
- 5.1.3 The test direction is base on about around 45° of vertical line.

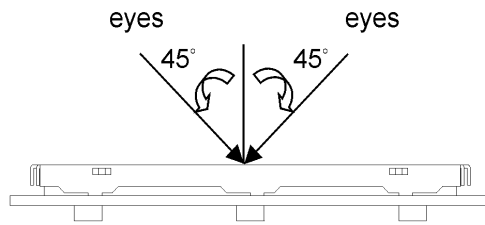

5.1.4 Definition of area:

- A Area : Viewing area.
- B Area : Out of viewing area.
(Outside viewing area)

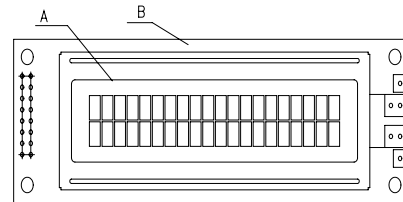

5.2 Basic principle:

- 5.2.1 It will accord to the AQL when the standard can not be described.
 - 5.2.2 The sample of the lowest acceptable quality level must be discussed by both supplier and customer when any dispute happened.
 - 5.2.3 Must add new item on time when it is necessary.
- 5.3 Standard of inspection:(Unit: mm)

6. Inspection specification

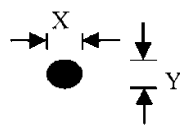
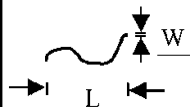
NO	Item	Criterion	AQL												
01	Electrical Testing	1.1 Missing vertical, horizontal segment, segment contrast defect. 1.2 Missing character , dot or icon. 1.3 Display malfunction. 1.4 No function or no display. 1.5 Current consumption exceeds product specifications. 1.6 LCD viewing angle defect. 1.7 Mixed product types. 1.8 Contrast defect.	0.65												
02	Black or white spots on LCD (display only)	2.1 White and black spots on display $\leq 0.25\text{mm}$, no more than three white or black spots present. 2.2 Densely spaced: No more than two spots or lines within 3mm.	2.5												
03	LCD black spots, white spots, contamination (non-display)	3.1 Round type : As following drawing $\phi = (x + y) / 2$  <table border="1" data-bbox="698 934 1161 1165"> <thead> <tr> <th>SIZE</th> <th>Acceptable Q TY</th> </tr> </thead> <tbody> <tr> <td>$\phi \leq 0.10$</td> <td>Accept no dense</td> </tr> <tr> <td>$0.10 < \phi \leq 0.20$</td> <td>2</td> </tr> <tr> <td>$0.20 < \phi \leq 0.25$</td> <td>1</td> </tr> <tr> <td>$0.25 < \phi$</td> <td>0</td> </tr> </tbody> </table>	SIZE	Acceptable Q TY	$\phi \leq 0.10$	Accept no dense	$0.10 < \phi \leq 0.20$	2	$0.20 < \phi \leq 0.25$	1	$0.25 < \phi$	0	2.5		
		SIZE	Acceptable Q TY												
$\phi \leq 0.10$	Accept no dense														
$0.10 < \phi \leq 0.20$	2														
$0.20 < \phi \leq 0.25$	1														
$0.25 < \phi$	0														
3.2 Line type : (As following drawing)  <table border="1" data-bbox="641 1270 1185 1480"> <thead> <tr> <th>Length</th> <th>Width</th> <th>Acceptable Q TY</th> </tr> </thead> <tbody> <tr> <td>--</td> <td>$W \leq 0.02$</td> <td>Accept no dense</td> </tr> <tr> <td>$L \leq 3.0$</td> <td>$0.02 < W \leq 0.03$</td> <td rowspan="2">2</td> </tr> <tr> <td>$L \leq 2.5$</td> <td>$0.03 < W \leq 0.05$</td> </tr> <tr> <td>--</td> <td>$0.05 < W$</td> <td>As round type</td> </tr> </tbody> </table>	Length	Width	Acceptable Q TY	--	$W \leq 0.02$	Accept no dense	$L \leq 3.0$	$0.02 < W \leq 0.03$	2	$L \leq 2.5$	$0.03 < W \leq 0.05$	--	$0.05 < W$	As round type	2.5
Length	Width	Acceptable Q TY													
--	$W \leq 0.02$	Accept no dense													
$L \leq 3.0$	$0.02 < W \leq 0.03$	2													
$L \leq 2.5$	$0.03 < W \leq 0.05$														
--	$0.05 < W$	As round type													

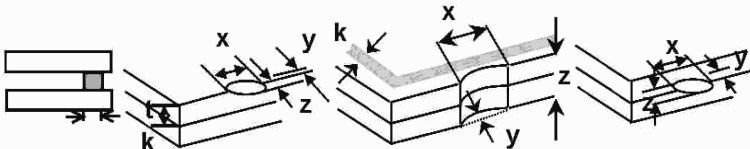
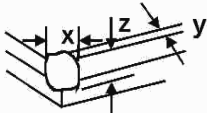
NO	Item	Criterion	AQL																		
04	Polarizer bubbles	<p>If bubbles are visible, judge using black spot specifications ,not easy to find, must check in specify direction</p> <table border="1"> <thead> <tr> <th>Size ϕ</th> <th>Acceptable Q TY</th> </tr> </thead> <tbody> <tr> <td>$\phi \leq 0.20$</td> <td>Accept no dense</td> </tr> <tr> <td>$0.20 < \phi \leq 0.50$</td> <td>3</td> </tr> <tr> <td>$0.50 < \phi \leq 1.00$</td> <td>2</td> </tr> <tr> <td>$1.00 < \phi$</td> <td>0</td> </tr> <tr> <td>Total Q TY</td> <td>3</td> </tr> </tbody> </table>	Size ϕ	Acceptable Q TY	$\phi \leq 0.20$	Accept no dense	$0.20 < \phi \leq 0.50$	3	$0.50 < \phi \leq 1.00$	2	$1.00 < \phi$	0	Total Q TY	3	2.5						
Size ϕ	Acceptable Q TY																				
$\phi \leq 0.20$	Accept no dense																				
$0.20 < \phi \leq 0.50$	3																				
$0.50 < \phi \leq 1.00$	2																				
$1.00 < \phi$	0																				
Total Q TY	3																				
05	Scratches	Follow NO.3 LCD black spots, white spots, contamination																			
06	Chipped glass	<p>Symbols : x : Chip length y : Chip width z : Chip thickness k : Seal width t : Glass thickness a : LCD side length L : Electrode pad length</p> <p>6.1 General glass chip : 6.1.1 Chip on panel surface and crack between panels :</p>  <table border="1"> <thead> <tr> <th>z : Chip thickness</th> <th>y : Chip width</th> <th>x : Chip length</th> </tr> </thead> <tbody> <tr> <td>$Z \leq 1/2t$</td> <td>Not over viewing area</td> <td>$x \leq 1/8a$</td> </tr> <tr> <td>$1/2t < z \leq 2t$</td> <td>Not exceed 1/3k</td> <td>$x \leq 1/8a$</td> </tr> </tbody> </table> <p>⊙ If there are 2 or more chips, x is the total length of each chip.</p> <p>6.1.2 Corner crack :</p>  <table border="1"> <thead> <tr> <th>z : Chip thickness</th> <th>y : Chip width</th> <th>x : Chip length</th> </tr> </thead> <tbody> <tr> <td>$Z \leq 1/2t$</td> <td>Not over viewing area</td> <td>$x \leq 1/8a$</td> </tr> <tr> <td>$1/2t < z \leq 2t$</td> <td>Not exceed 1/3k</td> <td>$x \leq 1/8a$</td> </tr> </tbody> </table> <p>⊙ If there are 2 or more chips, x is the total length of each chip.</p>	z : Chip thickness	y : Chip width	x : Chip length	$Z \leq 1/2t$	Not over viewing area	$x \leq 1/8a$	$1/2t < z \leq 2t$	Not exceed 1/3k	$x \leq 1/8a$	z : Chip thickness	y : Chip width	x : Chip length	$Z \leq 1/2t$	Not over viewing area	$x \leq 1/8a$	$1/2t < z \leq 2t$	Not exceed 1/3k	$x \leq 1/8a$	2.5
z : Chip thickness	y : Chip width	x : Chip length																			
$Z \leq 1/2t$	Not over viewing area	$x \leq 1/8a$																			
$1/2t < z \leq 2t$	Not exceed 1/3k	$x \leq 1/8a$																			
z : Chip thickness	y : Chip width	x : Chip length																			
$Z \leq 1/2t$	Not over viewing area	$x \leq 1/8a$																			
$1/2t < z \leq 2t$	Not exceed 1/3k	$x \leq 1/8a$																			

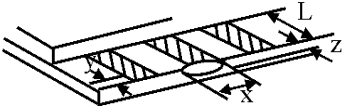
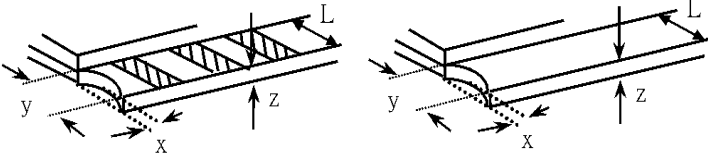
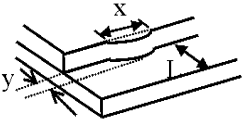
NO	Item	Criterion	AQL																
06	Glass crack	<p>Symbols :</p> <p>x : Chip length y : Chip width z : Chip thickness k : Seal width t : Glass thickness a : LCD side length L : Electrode pad length</p> <p>6.2 Protrusion over terminal :</p> <p>6.2.1 Chip on electrode pad :</p>  <table border="1" data-bbox="495 716 1166 814"> <tr> <td>y : Chip width</td> <td>x : Chip length</td> <td>z : Chip thickness</td> </tr> <tr> <td>$y \leq 0.5 \text{ mm}$</td> <td>$x \leq 1/8a$</td> <td>$0 < z \leq t$</td> </tr> </table> <p>6.2.2 Non-conductive portion :</p>  <table border="1" data-bbox="495 1087 1166 1178"> <tr> <td>y : Chip width</td> <td>x : Chip length</td> <td>z : Chip thickness</td> </tr> <tr> <td>$y \leq L$</td> <td>$x \leq 1/8a$</td> <td>$0 < z \leq t$</td> </tr> </table> <ul style="list-style-type: none"> ⊙ If the chipped area touches the ITO terminal, over 2/3 of the ITO must remain and be inspected according to electrode terminal specifications. ⊙ If the product will be heat sealed by the customer, the alignment mark must not be damaged. <p>6.2.3 Substrate protuberance and internal crack.</p>  <table border="1" data-bbox="748 1434 1166 1524"> <tr> <td>y : width</td> <td>x : length</td> </tr> <tr> <td>$y \leq 1/3L$</td> <td>$x \leq a$</td> </tr> </table>	y : Chip width	x : Chip length	z : Chip thickness	$y \leq 0.5 \text{ mm}$	$x \leq 1/8a$	$0 < z \leq t$	y : Chip width	x : Chip length	z : Chip thickness	$y \leq L$	$x \leq 1/8a$	$0 < z \leq t$	y : width	x : length	$y \leq 1/3L$	$x \leq a$	2.5
y : Chip width	x : Chip length	z : Chip thickness																	
$y \leq 0.5 \text{ mm}$	$x \leq 1/8a$	$0 < z \leq t$																	
y : Chip width	x : Chip length	z : Chip thickness																	
$y \leq L$	$x \leq 1/8a$	$0 < z \leq t$																	
y : width	x : length																		
$y \leq 1/3L$	$x \leq a$																		

NO	Item	Criterion	AQL
07	Cracked glass	The LCD with extensive crack is not acceptable.	2.5
08	Backlight elements	8.1 Illumination source flickers when lit. 8.2 Spots or scratches that appear when lit must be judged using LCD spot, lines and contamination standards. 8.3 Backlight doesn't light or color is wrong.	0.65 2.5 0.65
09	Bezel	9.1 Bezel may not have rust, be deformed or have fingerprints, stains or other contamination. 9.2 Bezel must comply with job specifications.	2.5 0.65
10	PCB \ COB	10.1 COB seal may not have pinholes larger than 0.2mm or contamination. 10.2 COB seal surface may not have pinholes through to the IC. 10.3 The height of the COB should not exceed the height indicated in the assembly diagram. 10.4 There may not be more than 2mm of sealant outside the seal area on the PCB. And there should be no more than three places. 10.5 No oxidation or contamination PCB terminals. 10.6 Parts on PCB must be the same as on the production characteristic chart. There should be no wrong parts, missing parts or excess parts. 10.7 The jumper on the PCB should conform to the product characteristic chart. 10.8 If solder gets on bezel tab pads, LED pad, zebra pad or screw hole pad, make sure it is smoothed down.	2.5 2.5 0.65 2.5 2.5 0.65 0.65 2.5
11	Soldering	11.1 No unmelted solder paste may be present on the PCB. 11.2 No cold solder joints, missing solder connections, oxidation or icicle. 11.3 No residue or solder balls on PCB. 11.4 No short circuits in components on PCB.	2.5 2.5 2.5 0.65

NO	Item	Criterion	AQL
12	General appearance	12.1 No oxidation, contamination, curves or, bends on interface Pin (OLB) of TCP.	2.5
		12.2 No cracks on interface pin (OLB) of TCP.	0.65
		12.3 No contamination, solder residue or solder balls on product.	2.5
		12.4 The IC on the TCP may not be damaged, circuits.	2.5
		12.5 The uppermost edge of the protective strip on the interface pin must be present or look as if it cause the interface pin to sever.	2.5
		12.6 The residual rosin or tin oil of soldering (component or chip component) is not burned into brown or black color.	2.5
		12.7 Sealant on top of the ITO circuit has not hardened	2.5
		12.8 Pin type must match type in specification sheet.	0.65
		12.9 LCD pin loose or missing pins.	0.65
		12.10 Product packaging must the same as specified on packaging specification sheet.	0.65
		12.11 Product dimension and structure must conform to product specification sheet .	0.65
		12.12 The appearance of Heat Seal should not admit any dirt and break.	

4.2 Standard Specification for Reliability

1. Standard Specifications for Reliability of LCD Module

No	Item	Description
01	High temperature operation	The sample should be allowed to stand at 50 °C for 240 (-0, +48) hours under driving condition.
02	Low temperature operation	The sample should be allowed to stand at 0 °C for 240 (-0, +48) hours under driving condition.
03	High temperature resistance	The sample should be allowed to stand at 70 °C for 240 (-0,+48) hours under no-load condition, and then returning it to normal temperature condition, and allowing it stand for 30 minutes.
04	Low temperature resistance	The sample should be allowed to stand at -20°C for 240 (-0,+48) hours under no-load condition, then returning it to normal temperature condition, and allowing it stand for 24 hours.
05	Moisture resistance	The sample should be allowed to stand at 40°C , 90 % RH MAX for 240 (-0,+48) hours under no-load condition excluding the polarizer, then taking it out and drying it at normal temperature.
06	Thermal shock resistance	The sample should be allowed to stand the following 10 cycles of operation: -40 °C for 30 minutes → normal temperature for 5 minutes → +80 °C for 30 minutes → normal temperature for 5 minutes, as one cycle.
07	ESD (Electrostatic Discharge)	Human Body Model: 2000 volt electrical discharge from a 100 pF capacitor to the tested device in series with a 1500 ohm resistor. Apply V_{DD} & V_{SS} to LCD module unit. Test for functionality no missing lines after the discharge, but LCD module may reset. Machine Model: 200 volt electrical discharge from a 200 pF capacitor to the tested device with no series resistance. Apply to V_{DD} & V_{SS} to LCD module unit without including hand phone. Test for functionality no any missing line after the discharge but LCD module can be reset if display off.

2. Testing Conditions and Inspection Criteria

For the final test the testing sample must be stored at room temperature for 24 hours, after the tests listed in Table 4.2, Standard specifications for Reliability have been executed in order to ensure stability.

NO	Item	Test Model	Inspection Criteria
01	Current Consumption	Refer To Specification	The current consumption should conform to the product specification.
02	Contrast	Refer To Specification	After the tests have been executed, the contrast must be larger than half of its initial value prior to the tests.
03	Appearance	Visual inspection	Defect free.

3. Life Time

Life time	Functions, performance, appearance, etc. shall be free from remarkable deterioration within 50,000 hours under ordinary operating and storage conditions room temperature ($25 \pm 10^{\circ}\text{C}$), normal humidity ($45 \pm 20\% \text{ RH}$), and in area not exposed to direct sun light. (Life time of backlight, please refer to Data about backlight .)
-----------	------------------------------------------------------------------------------------------------------------------------------------------------------------------------------------------------------------------------------------------------------------------------------------------------------------------------------------------------------------------------

Note: From our experience the life time of high humidity operation and high temperature operation as above mentioned could be achieved.

4.3 Precautions in Use of LCM

4.3.1 Handling of LCM

- Don't give external shock.
- Don't apply excessive force on the surface.
- Liquid in LCD is hazardous substance. Must not lick and swallow. when the liquid is attach to your hand, skin, cloth etc. Wash it out thoroughly and immediately.
- Don't operate it above the absolute maximum rating.
- Don't disassemble the LCM.

4.3.2 Storage

- Store in an ambient temperature of 5°C to 45°C, and in a relative humidity of 40% to 60%. Don't expose to sunlight or fluorescent light.
- Storage in a clean environment, free from dust, active gas, and solvent.
- Store in anti-static electricity container.
- Store without any physical load.

4.3.3 Soldering

- Use the high quality solder. (60-63% tin mixed with lead)
- Iron: no higher than 260°C and less than 3-4 sec during soldering.
- Soldering: only to the I/O terminals.
- Rewiring: no more than 3 times.

A.9 4 × 20 Character LCD Datasheet

RN1600

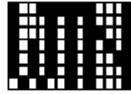

GENERAL SPECIFICATIONS FOR CHARACTER LCD MODULE

PIN ASSIGNMENT

PIN NO	SYMBOL	LEVEL	FUNCTION	PIN NO	SYMBOL	LEVEL	FUNCTION
1	Vss	—	Power Supply 0V (GND) +5V for LCD Drive	5	R/W	H/L	H:Data Read (Module→MPU) L:Data Write (Module←MPU)
2	Vcc	—		6	E	H,H→	Enable Signal
3	V0	—		7	DB0	H/L	Data Bus Line
4	RS	H/L	Register Select Signal Register H: Data Input Select L: Instruction Input	14	DB7		

* Interface between Data Bus line and 4- bit or 8-bit MPU is available. Data transfer are made in twice in case of 4-bit MPU. and once in case of 8-bit MPU.

TIMING CHART

ITEM	SYMBOL	Measuring Condition	STANDARD VALUE			UNIT
			MIN.	TYP.	MAX.	
Enable Cycle Time	t_{cycE}	Figs. 1,2	1000	—	—	ns
Enable Pulse Width, High Level	PW_{EH}	Figs. 1,2	450	—	—	ns
Enable Rise and Decay Time	t_{Er}, t_{Ef}	Figs. 1,2	—	—	25	ns
Address Setup Time, RS, R/W-E	t_{AS}	Figs. 1,2	140	—	—	ns
Data Delay Time	t_{DDR}	Figs. 2	—	—	320	ns
Data Setup Time	t_{DSW}	Figs. 1	195	—	—	ns
Data Hold Time (Write Operation)	t_H	Figs. 1	10	—	—	ns
Data Hold Time (Read Operation)	t_{DHR}	Figs. 2	20	—	—	ns
Address Hold Time	t_{AH}	Figs. 1,2	10	—	—	ns

FIG 1. WRITE OPERATION

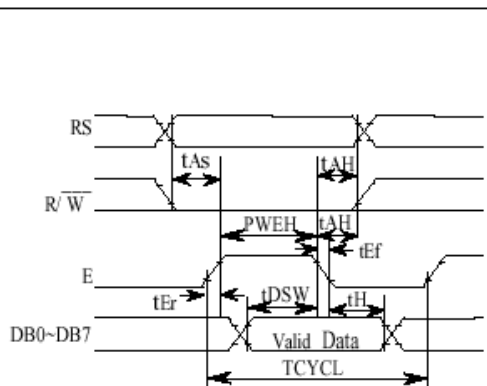

(WRITE DATA FROM MPU TO MODULE)

FIG 2. READ OPERATION

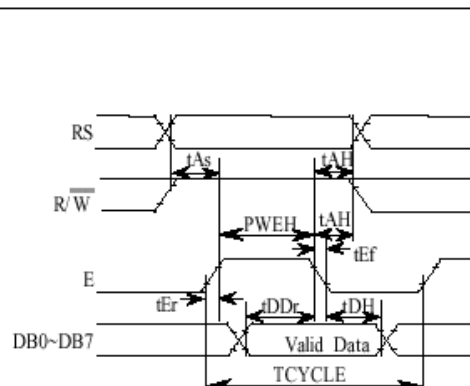

(READ DATA FROM MODULE TO MPU)

Instruction	Code										Description	Execution Time (max) (when fcp or fosc is 250KHz)
	RS	R/W	DB7	DB6	DB5	DB4	DB3	DB2	DB1	DB0		
Clear Display	0	0	0	0	0	0	0	0	0	1	Clears entire display and sets DD RAM address 0 in address counter.	1.64 ms
Return Home	0	0	0	0	0	0	0	0	1	*	Sets DD RAM address 0 in address counter. Also returns display being shifted to original position. DD RAM contents remain unchanged.	1.64 ms
Entry Mode Set	0	0	0	0	0	0	0	1	1/D	S	Sets cursor move direction and specifies shift of display. These operations are performed during data write and read.	40 μ s
Display On / Off Control	0	0	0	0	0	0	1	D	C	B	Sets ON/OFF of entire display (D), Cursor ON/OFF (C), and blink of cursor position character (B).	40 μ s
Cursor or Display Shift	0	0	0	0	0	1	S/C	R/L	*	*	Moves cursor & shifts display without changing DD RAM contents.	40 μ s
Function Set	0	0	0	0	1	DL	N	F	*	*	Sets interface data length (DL), number of display lines (L) and character fonts (F).	40 μ s
Set CG RAM Address	0	0	0	1	ACG					Sets CG RAM address. CG RAM data is sent and received after this setting.		40 μ s
Set DD RAM Address	0	0	1	ADD					Sets DD RAM address. CG RAM data is sent and received after this setting.		40 μ s	
Read Busy Flag and Address	0	1	BF	AC					Reads Busy flag (BF) indicating internal operation is being performed and reads address counter contents.		0 μ s	
Write Data to CG or DD RAM	0	0	Write Data					Writes data into DD RAM or CG RAM		40 μ s		
Read Data from CG or DD RAM	0	0	Read Data					Reads data into DD ram or CG RAM		40 μ s		
	I/D = 1:Increment I/D = 0:Decrement S = 1:Accompanies display shift S/C = 1:Display shift S/C = 0:Cursor move R/L = 1:Shift to the right R/L = 0:Shift to the left DL = 1:8 bits, DL = 0:4 bits N = 1:2 Lines, N = 0:1 line F = 1:5x 10 dots, F=0:5x 7 dots FB = 1:Internally operating FB = 0:Can accept instruction										DD RAM: Display data RAM CG RAM: Character generator RAM ACG: CG RAM Address ADD: DD RAM Address : Corresponds to cursor address AC: Address counter used for both DD and CG RAM address.	Execution time changes when frequency changes Example: When fcp or fosc is 270 KHz: $40 \mu s \times \frac{250}{270} = 37 \mu s$

If the power supply conditions for correctly operating the internal reset circuit are not met, initialization by instruction is required, or use the following procedure for initialization.

■ Instructions

1) 8 Bit Interface

2) 4 bit Interface

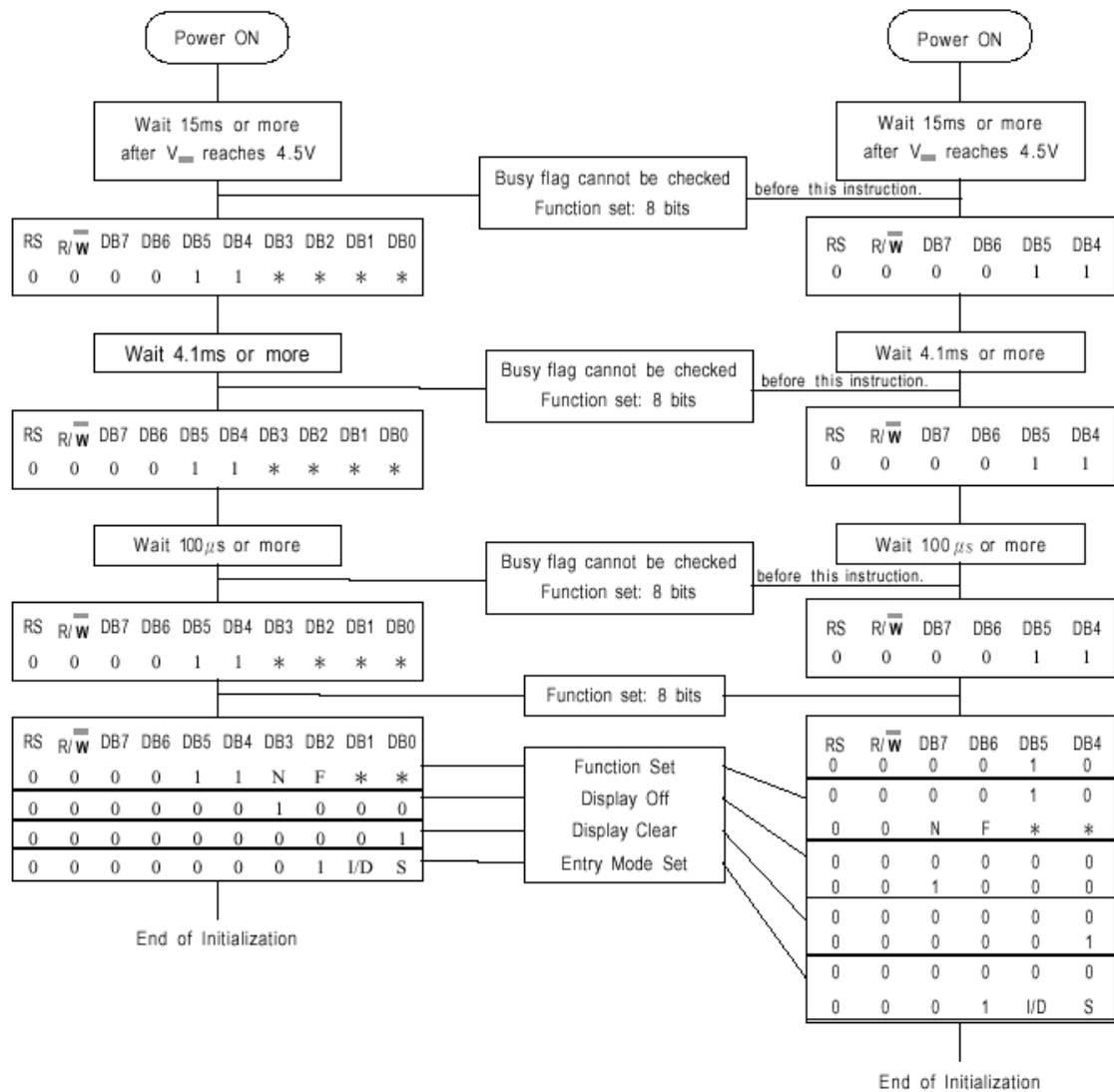

· Busy flag be checked after following instructions are completed. If busy flag is not checked, the waiting time between instructions should be longer than the execution time of these instructions.

		Higher 4-bit (D4 to D7) of Character Code (Hexadecimal)																
		0	1	2	3	4	5	6	7	8	9	A	B	C	D	E	F	
Lower 4-bit (D0 to D3) of Character Code (Hexadecimal)	0	CG RAM (1)			0	@	P	`	P				ー	夕	ミ	α	p	
	1	CG RAM (2)		!	1	A	Q	a	¶				。	ア	チ	△	ä	q
	2	CG RAM (3)		"	2	B	R	b	r				「	イ	ツ	×	β	θ
	3	CG RAM (4)		#	3	C	S	c	s				」	ウ	テ	ε	ε	∞
	4	CG RAM (5)		\$	4	D	T	d	t				、	エ	ト	μ	μ	Ω
	5	CG RAM (6)		%	5	E	U	e	u				・	オ	ナ	1	0	Ü
	6	CG RAM (7)		&	6	F	V	f	v				ヲ	カ	ニ	ヨ	p	Σ
	7	CG RAM (8)		'	7	G	W	g	w				ア	キ	ヌ	ラ	g	π
	8	CG RAM (1)		(8	H	X	h	x				イ	ク	ネ	リ	、	Σ
	9	CG RAM (2))	9	I	Y	i	y				ウ	ケ	ル	、	、	γ
	A	CG RAM (3)		*	=	J	Z	j	z				エ	コ	ハ	レ	j	キ
	B	CG RAM (4)		+	;	K	[k	{				オ	サ	ヒ	ロ	°	π
	C	CG RAM (5)		,	<	L	¥	l	!				カ	シ	フ	ワ	φ	円
	D	CG RAM (6)		-	=	M]	m	}				ユ	ス	ハ	ン	キ	÷
	E	CG RAM (7)		.	>	N	^	n	+				ヨ	セ	ホ	°	ハ	
	F	CG RAM (8)		/	?	O	_	o	+				ツ	ツ	マ	°	Ö	■

Electrical Characteristics

Item	Symbol	Condition	Min	Typ	Max
Input Voltage (high)	Vih	H Level	2.2 V	—	Vdd
Input Voltage (low)	Vil	L Level	0 V	—	0.6 V
Recommended LCD Driving Voltage (Standard Temp.)	Vdd - Vo	0°C	—	4.8 V	5.4 V
		25°C	4.2 V	4.6 V	—
		50°C	3.9 V	4.3 V	—
Recommended LCD Driving Voltage (Wide Temp.)	Vdd - Vo	-20°C	—	6.4 V	7.2 V
		0°C	—	4.8 V	—
		50°C	—	4.3 V	—
		70°C	3.7 V	4.2 V	—
Power Supply Current	Idd	Vdd = 5.0 V v = 270 kHz	—	0.5 mA	1.0 mA
LED Backlight Voltage	Vf	R = 6.8 Ω	—	4.6 V	5.0 V
LED Backlight Current	If	R = 6.8 Ω	—	240 mA	480 mA

INDEX

A

- A/D Converter Card
 - A/D converter inputs
 - 4–20 mA current measurements 58
 - calibration 59, 60, 61
 - differential measurements . 57
 - sample programs 61
 - single-ended measurements 56
 - analog input function calls
 - rn_anaIn 67
 - rn_anaInCalib 71
 - rn_anaInConfig 65
 - rn_anaInDiff 69
 - rn_anaInmAmps 70
 - rn_anaInRdCalib 75
 - rn_anaInVolts 68
 - rn_anaInWrCalib 73
 - connection to master 51, 53, 83
 - power supplies 53
 - sample programs 62

C

- connectivity tools
 - Connectivity Kit 3
 - crimp tool 3

D

- D/A Converter Card
 - connection to master 85
 - D/A converter outputs 88
 - asynchronous updating .. 88
 - calibration 89
 - sample program 89
 - calibration constants 89
 - power limits 88
 - simultaneous updating .. 88

- function calls
 - rn_anaOut 93
 - rn_anaOutCalib 96
 - rn_anaOutConfig 88, 92
 - rn_anaOutRdCalib .. 94, 98
 - rn_anaOutStrobe 88, 95
 - rn_anaOutVolts 94
 - rn_anaOutWrCalib 97
- power supplies 85, 105
- sample programs 90
- Digital I/O Card
 - A/D converter inputs 27
 - calibration 27
 - analog input function calls 37
 - rn_anaIn 38
 - rn_anaInCalib 41
 - rn_anaInConfig 37
 - rn_anaInDiff 40
 - rn_anaInRdCalib 43
 - rn_anaInVolts 39
 - rn_anaInWrCalib 42
 - connection to master ... 17, 19
 - digital I/O function calls 34, 35
 - rn_digBankIn 34
 - rn_digBankOut 36
 - rn_digIn 34
 - rn_digOut 35
 - rn_digOutConfig 24, 35
 - digital inputs 23
 - switching threshold 23
 - digital outputs 24
 - sinking or sourcing 24
 - power supplies 19
 - sample programs 30
- dimensions
 - A/D Converter Card 78
 - D/A Converter Card 100
 - Digital I/O Card 45
 - Keypad/Display interface 142
 - Relay Card 116

- DIN rail mounting 4
 - components 4
- Dynamic C 18, 52, 84, 104, 120
 - downloading RabbitNet libraries 7
 - libraries 6, 30, 62, 90, 110, 128

F

- features
 - A/D Converter Card 52
 - D/A Converter Card 84
 - Digital I/O Card 18
 - Keypad/Display interface 120
 - Relay Card 104

I

- indicator LED
 - A/D Converter Card 55
 - D/A Converter Card 87
 - Digital I/O Card 22
 - Keypad/Display interface 124
 - Relay Card 108

J

- jumper configurations
 - A/D Converter Card 81
 - JP1 (analog voltage/4–20 mA measurement options) 81
 - jumper locations 81
 - Digital I/O Card 49
 - digital inputs 49
 - JP1 (RS-485 bias and termination resistors) 49
 - jumper locations 48
 - Keypad/Display interface jumper locations 126

K

K	
Digital I/O Card	25
Keypad/Display Interface Expansion Kit	
datasheets	
2 × 20 character LCD ..	164
2 × 6 keypad	161
3 × 4 keypad	162
4 × 10 keypad	163
4 × 20 character LCD ..	188
keypad connections	146
LCD connections	150
2 × 20 character LCD ..	151
4 × 20 character LCD ..	151
templates	
2 × 6 keypad	147
3 × 4 keypad	148
4 × 10 keypad	149

P

peripheral cards	
connection to master	1, 2
physical mounting	
A/D Converter Card	80
D/A Converter Card	102
Digital I/O Card	47
Keypad/Display interface	144
Relay Card	118
pinout	
A/D Converter headers	55
D/A Converter headers	87
Digital I/O Card headers ..	22
RabbitNet Keypad/Display interface headers	123
Relay Card headers	108
power supplies	
A/D Converter Card	53
D/A Converter Card ..	85, 105
Digital I/O Card	19
RabbitNet Keypad/Display interface	121
Relay Card	105
wiring diagram	
A/D Converter Card	54
D/A Converter Card	86
Digital I/O Card	20
Keypad/Display interface ..	122
Relay Card	106

R

RabbitNet	
Ethernet cables to connect	
peripheral cards	1, 2
general description	1
peripheral cards	2
A/D converter	2
D/A converter	3
digital I/O	2
display/keypad interface ..	3
OP7200 display	3
relay card	3
physical implementation	5
RabbitNet Keypad/Display interface	
buzzer	
function calls	
rn_keyBuzzer	130
rn_keyBuzzerAct	130
connection to master	121
display	
function calls	
rn_dispBacklight	136
rn_dispClear	137
rn_dispCmd	140
rn_dispCursor	138
rn_dispData	139
rn_dispGoto	137
rn_dispInit	135
rn_dispOnoff	136
rn_dispPrintf	138
rn_dispPutc	139
keypad	
function calls	
rn_keyConfig	132
rn_keyGet	134
rn_keyInit	132
rn_keyProcess	134
rn_keyUnget	134
LEDs	
function calls	
rn_keyLedOut	131
power supplies	121
sample programs	128
Relay Card	
connection to master	103, 105
function calls	
rn_Relay	112
rn_RelayAll	113
rn_RelayPwr	109, 114
power supplies	105
relay output	109
sample programs	110

RNET.LIB

function calls	
rn_comm_status	14
rn_device	8, 9
rn_echo	10
rn_enable_wdt	13
rn_find	
..... 10, 30, 32, 62, 90, 110	
rn_hitwd	13
rn_init	9
rn_read	11
rn_reset	12
rn_rst_status	14
rn_sw_wdt	12
rn_write	11

S

sample programs	8
A/D Converter Card	62
A/D converter inputs	
AIN_CALDIFF_CH.C	
..... 61, 62	
AIN_CALMA_CH.C	
..... 61, 63	
AIN_CALSE_ALL.C	
..... 61, 63	
AIN_CALSE_CH.C	
..... 61, 63	
AIN_RDDIFF_CH.C	
..... 61, 63	
AIN_RDMA_CH.C	
..... 61, 64	
AIN_RDSE_ALL.C ..	64
AIN_RDSE_CH.C	61, 64
AIN_READ_CAL-	
DATA.C	64
D/A Converter Card	90
calibration constants	
GETCALIB.C	89
DAC_ASYNC.C	90
DAC_CAL.C	91
DAC_READ_CAL-	
DATA.C	91
DAC_SYNC.C	91
Digital I/O Card	30
A/D converter inputs	
AIN_CALDIFF_CH.C	
..... 28, 32	
AIN_CALSE_CH.C	
..... 28, 32	
AIN_RDDIFF_CH.C	
..... 28, 32	
AIN_RDSE_CH.C	28, 33
AIN_SAMPLE.C	33

sample programs	specifications
Digital I/O Card (continued)	A/D Converter Card 78
digital I/O	dimensions 78
DIGBANKIN.C 30	electrical 79
DIGBANKOUT.C 31	header footprint 80
DIGIN.C 31	physical mounting 80
DIGOUT.C 32	relative pin 1 locations .. 80
RabbitNet Keypad/Display	temperature 79
interface 128	D/A Converter Card 100
ALPHANUM.C	dimensions 100
..... 128, 147, 151	electrical 101
BUZZER.C 128	header footprint 102
KEYBASIC.C 129, 147	physical mounting 102
LCDBASIC.C 129, 151	relative pin 1 locations 102
PONG.C 129, 147, 151	temperature 101
ZMENU.C 129, 152	Digital I/O Card 45
RabbitNet operation 8	dimensions 45
ECHOCHAR.C 8	electrical 46
ECHOTERM.C 8	header footprint 47
HWATCHDOG.C 8	physical mounting 47
SWATCHDOG.C 8	relative pin 1 locations .. 47
Relay Card 110	temperature 46
RELAY_ALL.C 110	Keypad/Display interface 142
RELAY_LOW_PWR.C	dimensions 142
..... 111	electrical 143
RELAY_SEQUENCE.C	header footprint 144
..... 111	physical mounting 144
software 18, 52, 84, 104, 120	relative pin 1 locations 144
downloading RabbitNet	temperature 143
libraries 7	Relay Card 116
libraries 6	dimensions 116
A/D Converter Card 62	electrical 117
D/A Converter Card 90	header footprint 118
Digital I/O Card 30	physical mounting 118
RabbitNet Keypad/Display	relative pin 1 locations 118
interface 128	temperature 117
Relay Card 110	status byte 15
RN_CFG_BL26.LIB 6	
RNET_AIN.LIB 30, 62	Z
RNET_AOUT.LIB 90	ZMENU
RNET_DIO.LIB 30	function calls
RNET_KEYIF.LIB 128	Zmenu_Config 154
RNET_LCDIF.LIB 128	
RNET_RELAY.LIB ... 110	
RabbitNet operation 9	
supporting libraries 6	
RN_CFG_BL25.LIB 6	
RN_CFG_OP72.LIB 6	
RN_CFG_PowerCore-	
FLEX.LIB 6	
RN_CFG_RCM33.LIB ... 6	
RNET.LIB 6	
RNET_DRIVER.LIB 6	



SCHEMATICS

090-0175 Digital I/O Card Schematic

www.rabbit.com/documentation/schemat/090-0175.pdf

090-0178 A/D Converter Card Schematic

www.rabbit.com/documentation/schemat/090-0178.pdf

090-0179 D/A Converter Card Schematic

www.rabbit.com/documentation/schemat/090-0179.pdf

090-0184 Relay Card Schematic

www.rabbit.com/documentation/schemat/090-0184.pdf

090-0192 RabbitNet Keypad/Display Interface Schematic

www.rabbit.com/documentation/schemat/090-0192.pdf

You may use the URL information provided above to access the latest schematics directly.



Компания «ЭлектроПласт» предлагает заключение долгосрочных отношений при поставках импортных электронных компонентов на взаимовыгодных условиях!

Наши преимущества:

- Оперативные поставки широкого спектра электронных компонентов отечественного и импортного производства напрямую от производителей и с крупнейших мировых складов;
- Поставка более 17-ти миллионов наименований электронных компонентов;
- Поставка сложных, дефицитных, либо снятых с производства позиций;
- Оперативные сроки поставки под заказ (от 5 рабочих дней);
- Экспресс доставка в любую точку России;
- Техническая поддержка проекта, помощь в подборе аналогов, поставка прототипов;
- Система менеджмента качества сертифицирована по Международному стандарту ISO 9001;
- Лицензия ФСБ на осуществление работ с использованием сведений, составляющих государственную тайну;
- Поставка специализированных компонентов (Xilinx, Altera, Analog Devices, Intersil, Interpoint, Microsemi, Aeroflex, Peregrine, Syfer, Eurofarad, Texas Instrument, Miteq, Cobham, E2V, MA-COM, Hittite, Mini-Circuits, General Dynamics и др.);

Помимо этого, одним из направлений компании «ЭлектроПласт» является направление «Источники питания». Мы предлагаем Вам помощь Конструкторского отдела:

- Подбор оптимального решения, техническое обоснование при выборе компонента;
- Подбор аналогов;
- Консультации по применению компонента;
- Поставка образцов и прототипов;
- Техническая поддержка проекта;
- Защита от снятия компонента с производства.

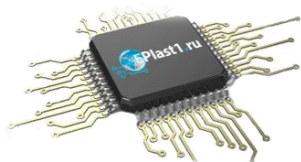

Как с нами связаться

Телефон: 8 (812) 309 58 32 (многоканальный)

Факс: 8 (812) 320-02-42

Электронная почта: org@eplast1.ru

Адрес: 198099, г. Санкт-Петербург, ул. Калинина, дом 2, корпус 4, литера А.