

Features

- Universal AC input / Full range (up to 295VAC)
- Constant current design
- Built-in active PFC function
- High efficiency up to 91%
- Protections: Short circuit / Over temperature
- Cooling by free air convection
- Fully isolated plastic case
- Class II power unit, no FG
- Class 2 power unit
- No load power consumption < 0.5W
- 5 years warranty

Applications

- LED bay lighting
- LED down lighting
- LED spot lighting
- LED mining lighting
- LED stage lighting

Description

HBG-60 series is one 60W single output AC/DC LED switching power supply, featuring the circular shape, specifically designed for the LED luminaries in circular form factor. HBG-60 series is provided in two types: the enclosed type (with the 94V-0 flame retardant plastic case) and the PCB type. The structure is built to make this series extremely easy to assemble with the heat sink of the lighting unit or to integrate into the mechanical design of the fixture. It is thus well suited to adopt HBG-60 with the lighting units such as circular shape LED bay lighting, LED down lighting, etc.

HBG-60 series accepts the input from 90VAC through 295VAC and is equipped with a built-in active PFC function. With the Class II design (without FG pin) and the double insulation cables, it is convenient for users to flexibly set up this series into various kinds of luminaries. The working efficiency is up to 91% and it can work at the ambient temperature between -40°C and 70°C under air convection. HBG-60 series is certified with global luminary related safety regulation.

Model Encoding

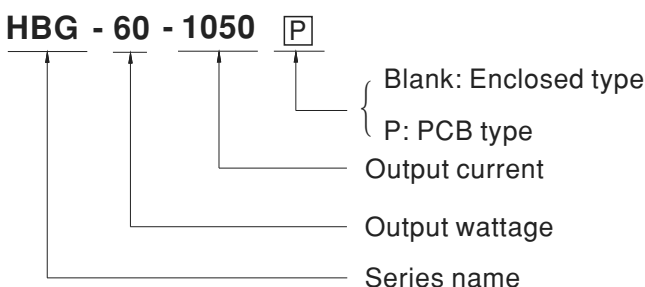



SPECIFICATION

MODEL		HBG-60-1050 <input type="checkbox"/>	HBG-60-1400 <input type="checkbox"/>	HBG-60-2100 <input type="checkbox"/>
OUTPUT	RATED CURRENT	1050mA	1400mA	2100mA
	CONSTANT CURRENT REGION Note.4	37 ~ 55V	28 ~ 43V	19 ~ 29V
	CURRENT ADJ. RANGE Note.4	680 ~ 1050mA	910 ~ 1400mA	1360mA ~ 2100mA
	CURRENT ACCURACY	±5.0%		
	RATED POWER	57.75W	60.2W	60.9W
	RIPPLE & NOISE (max.) Note.2	5Vp-p	4Vp-p	3Vp-p
	NO LOAD OUTPUT VOLTAGE (max.)	60V	50V	35V
	SETUP TIME	500ms / 230VAC 1200ms / 115VAC at 95% load		
INPUT	VOLTAGE RANGE Note.3	90 ~ 295VAC 127 ~ 417VDC		
	FREQUENCY RANGE	47 ~ 63Hz		
	POWER FACTOR (Typ.)	PF>0.97/115VAC, PF>0.95/230VAC, PF>0.9/277VAC at full load (Please refer to "Power Factor Characteristic" curve)		
	TOTAL HARMONIC DISTORTION	THD< 20% when output loading ≥65% at 115VAC/230VAC input and output loading ≥75% at 277VAC input		
	EFFICIENCY (Typ.)	91%	90%	90%
	AC CURRENT	0.7A/115VAC 0.4A/230VAC 0.3A/277VAC		
	INRUSH CURRENT (Typ.)	COLD START 45A(twidth=100μs measured at 50% Ipeak) at 230VAC		
	LEAKAGE CURRENT	<0.75mA / 240VAC		
PROTECTION	SHORT CIRCUIT	Hiccup mode, recovers automatically after fault condition is removed		
	OVER TEMPERATURE	Shut down o/p voltage, re-power on to recover		
ENVIRONMENT	WORKING TEMP.	-40 ~ +70°C (Refer to "Derating Curve")		
	WORKING HUMIDITY	20 ~ 95% RH non-condensing		
	STORAGE TEMP., HUMIDITY	-40 ~ +80°C, 10 ~ 95% RH		
	TEMP. COEFFICIENT	±0.03%/°C (0 ~ 60°C)		
	VIBRATION	10 ~ 500Hz, 5G 12min./1cycle, period for 72min. each along X, Y, Z axes		
SAFETY & EMC	SAFETY STANDARDS	UL8750, CSA C22.2 No. 250.13-12, ENEC EN61347-1 & EN61347-2-13 independent, EN62384 approved		
	WITHSTAND VOLTAGE	I/P-O/P:3.75KVAC		
	ISOLATION RESISTANCE	I/P-O/P:100M Ohms / 500VDC / 25°C / 70% RH		
	EMC EMISSION	Compliance to EN55015, EN61000-3-2 Class C (≥65% load) ; EN61000-3-3		
	EMC IMMUNITY	Compliance to EN61000-4-2,3,4,5,6,8,11; EN61547, EN55024, light industry level(surge 2KV), criteria A		
OTHERS	MTBF	452Khrs min. MIL-HDBK-217F (25°C)		
	DIMENSION	Enclosed type: φ 110mm * 60.5mm (D * H) PCB type: φ 99mm *26mm (D * H)		
	PACKING	Enclosed type: 0.5Kg; 20pcs/ 11Kg/ 0.94CUFT PCB type:0.21Kg; 32pcs/ 7.7Kg/ 0.68CUFT		
NOTE	<ol style="list-style-type: none"> All parameters NOT specially mentioned are measured at 230VAC input, rated load and 25°C of ambient temperature. Ripple & noise are measured at 20MHz of bandwidth by using a 12" twisted pair-wire terminated with a 0.1uf & 47uf parallel capacitor. Derating may be needed under low input voltage. Please check the static characteristics for more details. Please refer to "DRIVING METHODS OF LED MODULE". The power supply is considered as a component that will be operated in combination with final equipment. Since EMC performance will be affected by the complete installation, the final equipment manufacturers must re-qualify EMC Directive on the complete installation again. Direct connecting to LEDs is suggested, but is not suitable for using additional drivers. Constant current operation region is about 65%~100% rated output voltage, and the output power must be more than rated output power. This is the suitable operation region for LED related applications, but please reconfirm special electrical requirements for some specific system design. 			

■ Block Diagram

fosc : 50KHz

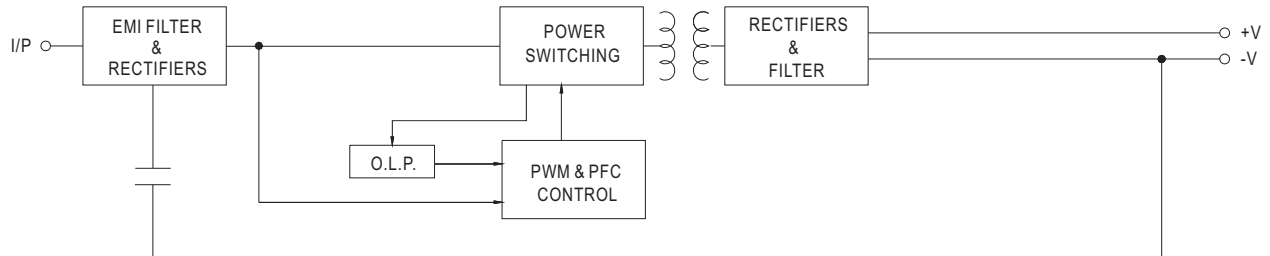

■ Derating Curve

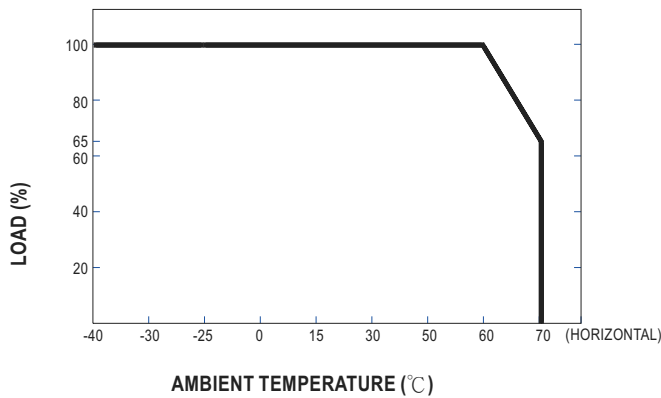

■ Static Characteristics

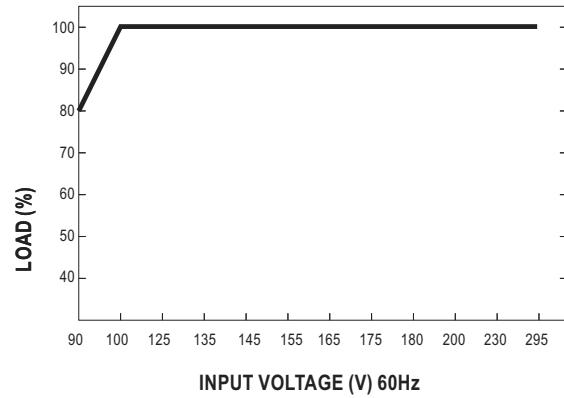

■ Power Factor Characteristic

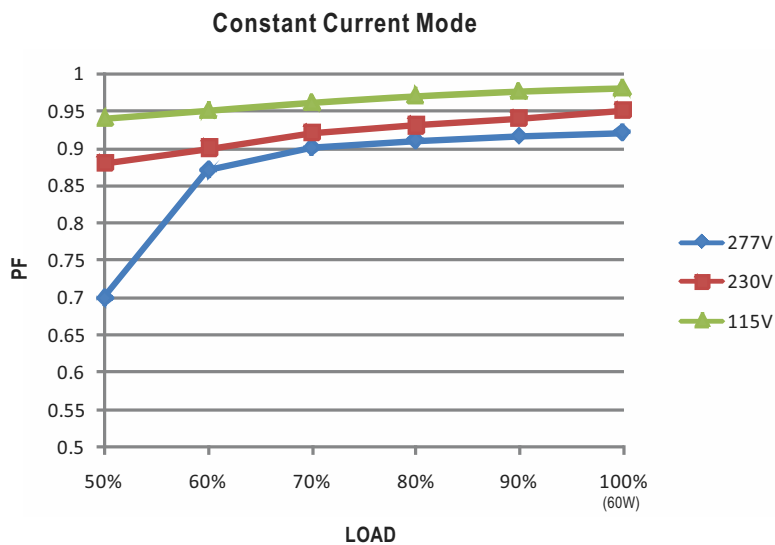

EFFICIENCY vs LOAD (1050mA Model)

HBG-60 series possess superior working efficiency that up to 91% can be reached in field applications.

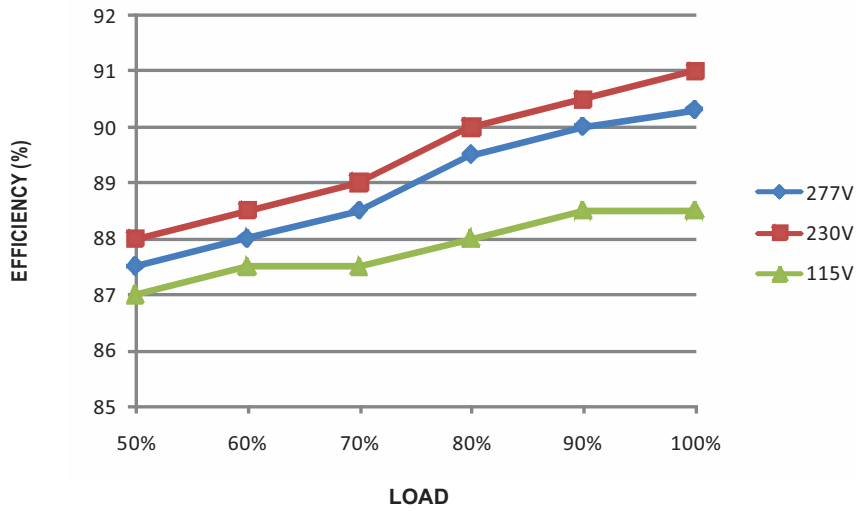

DRIVING METHODS OF LED MODULE

This LED power supply is suggested to work in constant current mode area (CC) to drive the LEDs.

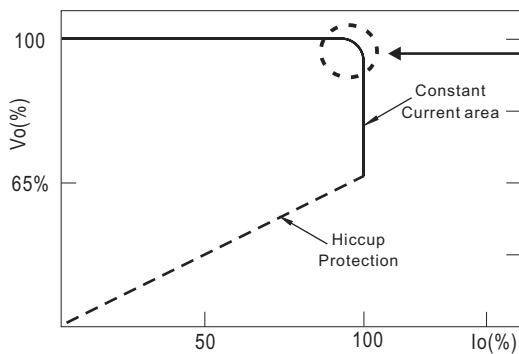

Typical LED power supply I-V curve

In the constant current region, the highest voltage at the output of the driver depends on the configuration of the end systems.
Should there be any compatibility issues, please contact MEAN WELL.

■ Mechanical Specification

Case No.HBG-60 Unit:mm

Blank type:(HBG-60-_)

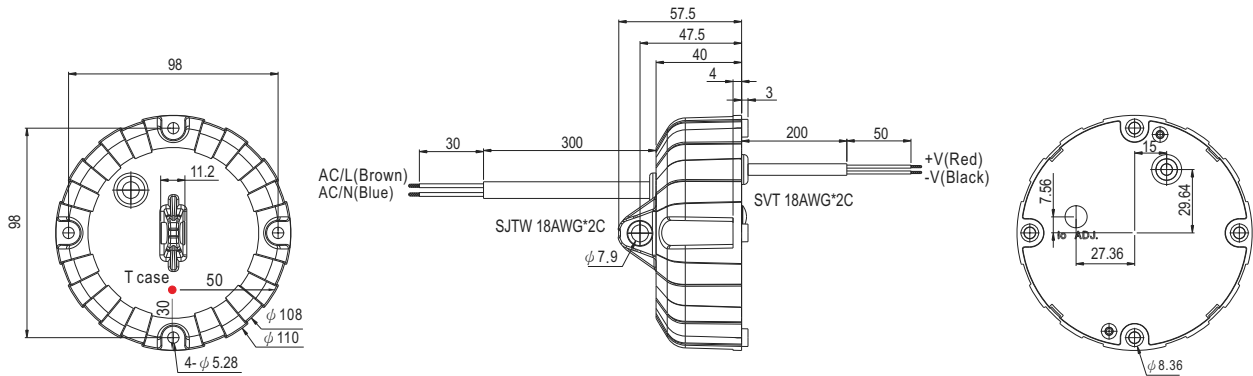

※ T case: Max. Case Temperature.

P type:(HBG-60-P)

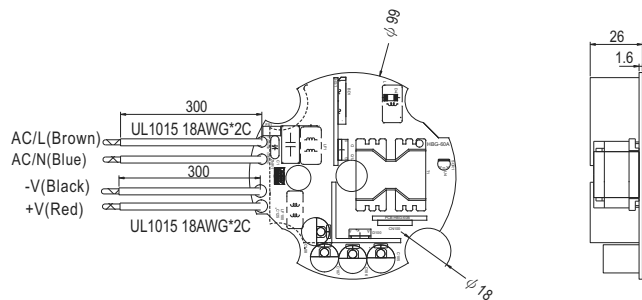

Caution

- Please inspect the appearance of the product for completeness if the package is damaged. There should not be any cracks.
- Please do not drop or bump the product.
- All screws including the suspension screw should be paired with a spring washer and locked tight.
- The entire luminaire, including the power supply should be limited to less than 5Kg.
- The luminaire should be cautiously protected throughout packaging and transportation to avoid damage due to shock.
- Please thoroughly perform the cautionary notes above to prevent the possibility of the luminaire falling and injuring personnel.



Компания «ЭлектроПласт» предлагает заключение долгосрочных отношений при поставках импортных электронных компонентов на взаимовыгодных условиях!

Наши преимущества:

- Оперативные поставки широкого спектра электронных компонентов отечественного и импортного производства напрямую от производителей и с крупнейших мировых складов;
- Поставка более 17-ти миллионов наименований электронных компонентов;
- Поставка сложных, дефицитных, либо снятых с производства позиций;
- Оперативные сроки поставки под заказ (от 5 рабочих дней);
- Экспресс доставка в любую точку России;
- Техническая поддержка проекта, помощь в подборе аналогов, поставка прототипов;
- Система менеджмента качества сертифицирована по Международному стандарту ISO 9001;
- Лицензия ФСБ на осуществление работ с использованием сведений, составляющих государственную тайну;
- Поставка специализированных компонентов (Xilinx, Altera, Analog Devices, Intersil, Interpoint, Microsemi, Aeroflex, Peregrine, Syfer, Eurofarad, Texas Instrument, Miteq, Cobham, E2V, MA-COM, Hittite, Mini-Circuits, General Dynamics и др.);

Помимо этого, одним из направлений компании «ЭлектроПласт» является направление «Источники питания». Мы предлагаем Вам помощь Конструкторского отдела:

- Подбор оптимального решения, техническое обоснование при выборе компонента;
- Подбор аналогов;
- Консультации по применению компонента;
- Поставка образцов и прототипов;
- Техническая поддержка проекта;
- Защита от снятия компонента с производства.



Как с нами связаться

Телефон: 8 (812) 309 58 32 (многоканальный)

Факс: 8 (812) 320-02-42

Электронная почта: org@eplast1.ru

Адрес: 198099, г. Санкт-Петербург, ул. Калинина, дом 2, корпус 4, литера А.