

OPTION A

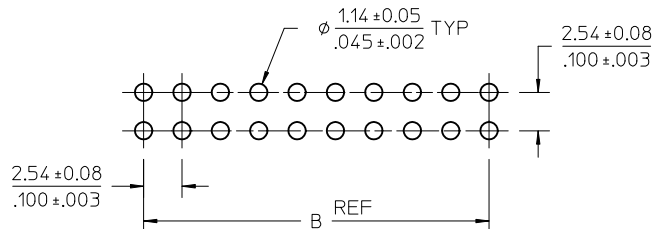

PCB LAYOUT: COMPONENT SIDE
TYPICAL PCB THICKNESS: 2.36/1.093

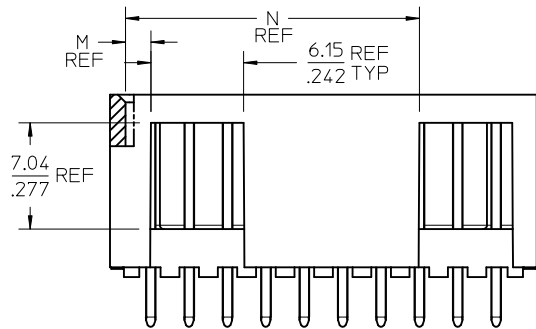
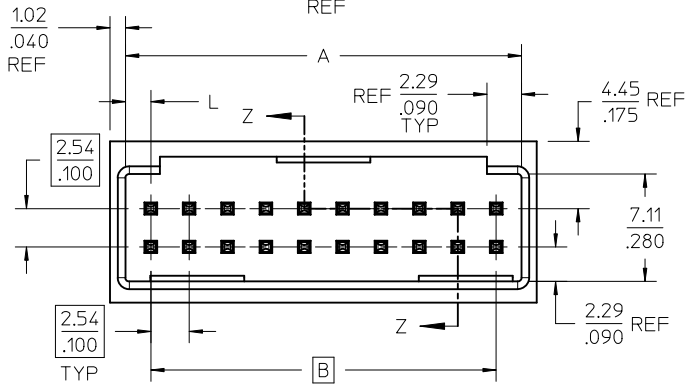
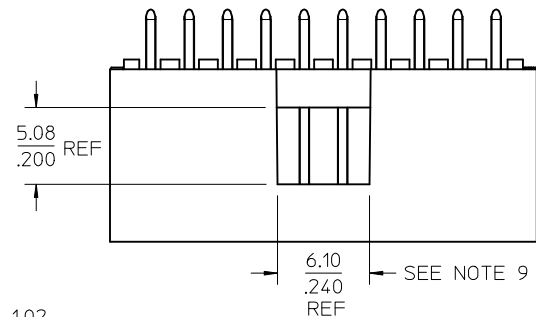
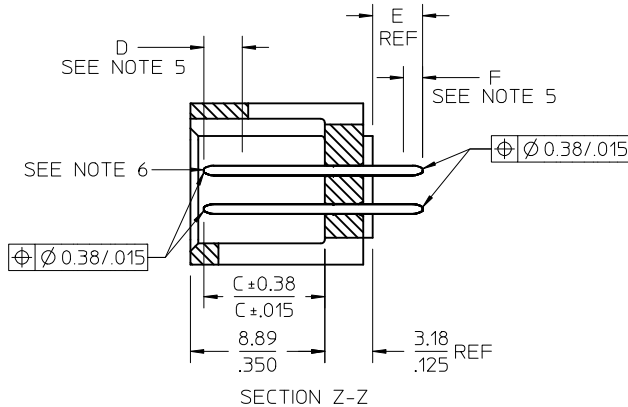

NOTES:

- MATERIAL: SHROUDED WAFER: GLASS FILLED, LIQUID CRYSTAL POLYMER, COLOR: BLACK, 94V-0. PINS: COPPER ALLOY.
- PLATING:
 - TIN 0.00381/.000150 MINIMUM TIN, OVER NICKEL UNDERPLATE OVERALL
 - 15 GOLD 0.00038/.000015 MINIMUM GOLD PLATE IN SELECTED AREA
 - 0.00191/.000075 MINIMUM TIN IN SELECTED AREA OVER NICKEL UNDERPLATE OVERALL
 - 30 GOLD 0.00076/.000030 MINIMUM GOLD PLATE IN SELECTED AREA
 - 0.00191/.000075 MINIMUM TIN IN SELECTED AREA, OVER NICKEL UNDERPLATE OVERALL
- PRODUCT SPECIFICATION: PS-70567.
- PACKAGING: SEE CHARTS
- MEASURE POINT FOR PLATING THICKNESS.
- PIN PUSHOUT FORCE: 4 LBS. MINIMUM IN DIRECTION INDICATED.
- FOR ILLUSTRATION PURPOSES, 20 (DUAL 10) CIRCUIT SIZE HEADER SHOWN.
- PIN SOLDERABILITY PER MOLEX SPEC. SMES-152.
- WINDOW NOT AVAILABLE ON 6 OR 8 CIRCUIT SIZE.
- THIS PART CONFORMS TO CLASS B REQUIREMENTS OF COSMETIC SPECIFICATION PS-45499-002.

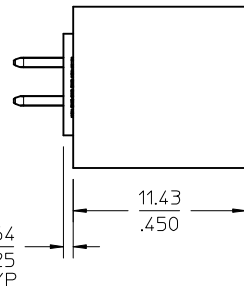
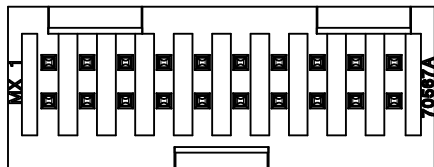

CKT	DIM A	DIM B	DIM L	DIM M	DIM N
06	8.43 .332	5.08 .200	1.68 .066	1.68 .066	
08	10.97 .432	7.62 .300	1.68 .066	1.68 .066	
10	13.51 .532	10.16 .400	1.68 .066	4.22 .166	
12	16.05 .632	12.70 .500	1.68 .066	4.22 .166	
14	18.59 .732	15.24 .600	1.68 .066	6.76 .266	
16	21.13 .832	17.78 .700	1.68 .066	6.76 .266	
18	23.67 .932	20.32 .800	1.68 .066	9.30 .366	
20	26.21 1.032	22.86 .900	1.68 .066	1.68 .066	19.46 .766
22	28.75 1.132	25.40 1.000	1.68 .066	1.68 .066	22.00 .866
24	31.29 1.232	27.94 1.100	1.68 .066	1.68 .066	24.54 .966
26	33.83 1.332	30.48 1.200	1.68 .066	1.68 .066	27.08 1.066
28	36.37 1.432	33.02 1.300	1.68 .066	1.68 .066	29.62 1.166
30	38.91 1.532	35.56 1.400	1.68 .066	1.68 .066	32.16 1.266
32	41.45 1.632	38.10 1.500	1.68 .066	1.68 .066	34.70 1.366
34	43.99 1.732	40.64 1.600	1.68 .066	1.68 .066	37.24 1.466
36	46.53 1.832	43.18 1.700	1.68 .066	1.68 .066	39.78 1.566
38	49.07 1.932	45.72 1.800	1.68 .066	1.68 .066	42.32 1.666
40	51.61 2.032	48.26 1.900	1.68 .066	1.68 .066	44.86 1.766
42	54.15 2.132	50.80 2.000	1.68 .066	1.68 .066	47.40 1.866
44	56.69 2.232	53.34 2.100	1.68 .066	1.68 .066	49.94 1.966
46	59.23 2.332	55.88 2.200	1.68 .066	1.68 .066	52.48 2.066
48	61.77 2.432	58.42 2.300	1.68 .066	1.68 .066	55.02 2.166
50	64.31 2.532	60.96 2.400	1.68 .066	1.68 .066	57.56 2.266
52	66.85 2.632	63.50 2.500	1.68 .066	1.68 .066	60.10 2.366
54	69.39 2.732	66.04 2.600	1.68 .066	1.68 .066	62.64 2.466
56	71.93 2.832	68.58 2.700	1.68 .066	1.68 .066	65.18 2.566
58	74.47 2.932	71.12 2.800	1.68 .066	1.68 .066	67.72 2.666
60	77.01 3.032	73.66 2.900	1.68 .066	1.68 .066	70.26 2.766
62	79.55 3.132	76.20 3.000	1.68 .066	1.68 .066	72.80 2.866
64	82.09 3.232	78.74 3.100	1.68 .066	1.68 .066	75.34 2.966
66	84.63 3.332	81.28 3.200	1.68 .066	1.68 .066	77.88 3.066
68	87.17 3.432	83.82 3.300	1.68 .066	1.68 .066	80.42 3.166
70	89.71 3.532	86.36 3.400	1.68 .066	1.68 .066	82.96 3.266
72	92.25 3.632	88.90 3.500	1.68 .066	1.68 .066	85.50 3.366

REV	DESCRIPTION	QUALITY SYMBOLS
J	CORRECT PCB HOLE SIZE	▽=0
	EC NO: UCP2011-0294	▽=0
	DRWINAS BARRA 2010/08/02	▽=0
	CHYKD:DRORGAN 1988/03/10	
	IAPPR:MBANAKIS 2010/08/03	

GENERAL TOLERANCES (UNLESS SPECIFIED)	
mm	INCH
4 PLACES ± .005	± .0005
3 PLACES ± .010	± .0010
2 PLACES ± 0.13	± .010
1 PLACE ± 0.25	± .010
ANGULAR ± 1/2°	
DRAFT WHERE APPLICABLE MUST REMAIN WITHIN DIMENSIONS	

DIMENSION STYLE	
MM/IN	DATE
DRAWN BY	DATE
EIK	1988/03/10
CHECKED BY	DATE
EIK	1988/03/10
APPROVED BY	DATE
SMILLER	2010/03/31
MATERIAL NO. SEE TABLE	
DOCUMENT NO. SDA-70567-****	
SHEET NO. 1 OF 5	

SCALE	DESIGN UNITS	THIRD ANGLE PROJECTION
4:1	INCH	THIRD ANGLE PROJECTION
4 SIDES SHROUDED HEADER HIGH TEMP, (2.54)/.100 GRID W/ (.64)/.025 PINS		
MOLEX MOLEX INCORPORATED		
THIS DRAWING CONTAINS INFORMATION THAT IS PROPRIETARY TO MOLEX INCORPORATED AND SHOULD NOT BE USED WITHOUT WRITTEN PERMISSION		

OPTION B

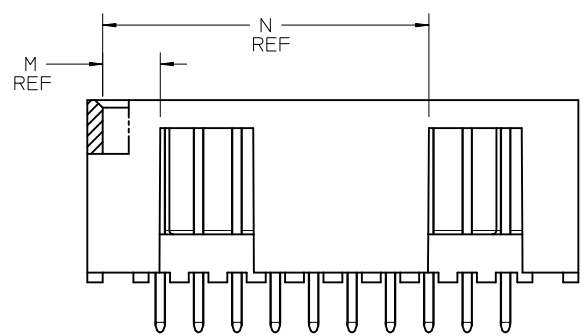
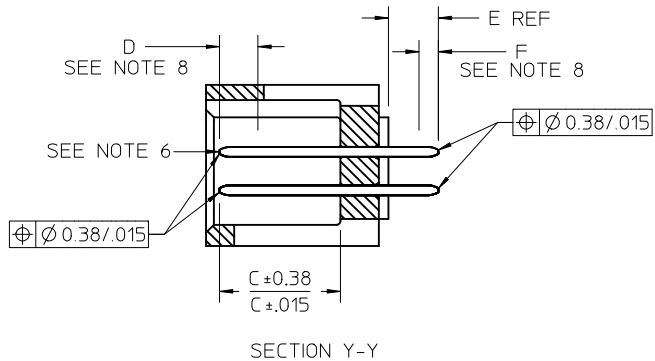
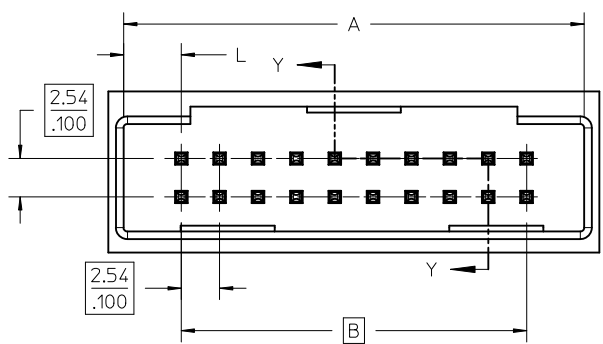
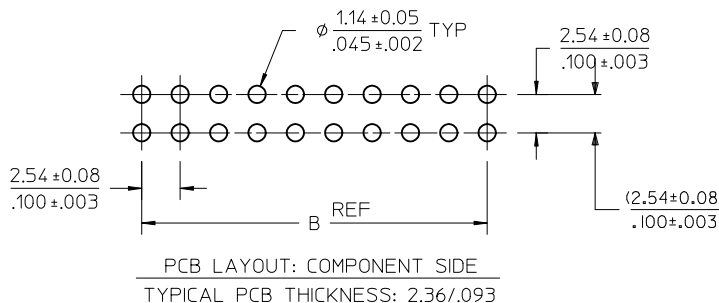
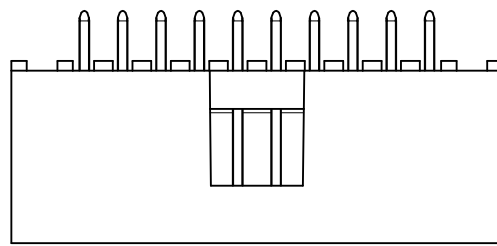

- NOTES:
- MATERIAL: SHROUDED WAFER: 30% G.F. LCP, COLOR: BLACK, 94V-0. PINS: COPPER ALLOY.
 - PLATING:
 TIN - (0.00381)/.000150 MINIMUM TIN OVER NICKEL UNDERPLATE OVERALL
 15 GOLD - (0.000381)/.000015 MINIMUM GOLD PLATE IN SELECTED AREA
 (0.00191)/.000075 MINIMUM TIN IN SELECTED AREA, OVER NICKEL UNDERPLATE OVERALL
 30 GOLD - (0.000761)/.000030 MINIMUM GOLD PLATE IN SELECTED AREA
 (0.00191)/.000075 MINIMUM TIN IN SELECTED AREA, OVER NICKEL UNDERPLATE OVERALL
 - PRODUCT SPECIFICATION: PS-70567.
 - PACKAGING: SEE CHARTS
 - PIN PUSHOUT FORCE: 4 LBS. MIN IN DIRECTION INDICATED.
 - FOR ILLUSTRATION PURPOSES, 20 (DUAL 10) CIRCUIT SIZE HEADER SHOWN.
 - PIN SOLDERABILITY PER MOLEX SPEC. SMES-152.
 - MEASURE POINT FOR PLATING THICKNESS.
 - WINDOW IS NOT AVAILABLE ON 6 CIRCUIT.
 - THIS PART CONFORMS TO CLASS B REQUIREMENTS OF COSMETIC SPECIFICATION PS-45499-002.
 - SEE SHEET 1 FOR ALL OTHER DIMENSIONS

CKT	DIM A	DIM B	DIM L	DIM M	DIM N
06	12.70	5.08	3.81	3.81	---
	.500	.200	.150	.150	---
08	15.24	7.62	3.81	3.81	---
	.600	.300	.150	.150	---
10	17.78	10.16	3.81	6.35	---
	.700	.400	.150	.150	---
12	20.32	12.70	3.81	6.35	---
	.800	.500	.150	.150	---
14	22.86	15.24	3.81	8.89	---
	.900	.600	.150	.350	---
16	25.40	17.78	3.81	8.89	---
	1.000	.700	.150	.350	---
18	27.94	20.32	3.81	11.43	---
	1.100	.800	.150	.450	---
20	30.48	22.86	3.81	3.81	21.59
	1.200	.900	.150	.150	.850
22	33.02	25.40	3.81	3.81	24.13
	1.300	1.000	.150	.150	.950
24	35.56	27.94	3.81	3.81	26.67
	1.400	1.100	.150	.150	1.050
26	38.10	30.48	3.81	3.81	29.21
	1.500	1.200	.150	.150	1.150
28	40.64	33.02	3.81	3.81	31.75
	1.600	1.300	.150	.150	1.250
30	43.18	35.56	3.81	3.81	34.29
	1.700	1.400	.150	.150	1.350
32	45.72	38.10	3.81	3.81	36.83
	1.800	1.500	.150	.150	1.450
34	48.26	40.64	3.81	3.81	39.37
	1.900	1.600	.150	.150	1.550
36	50.80	43.18	3.81	3.81	41.91
	2.000	1.700	.150	.150	1.650
38	53.34	45.72	3.81	3.81	44.45
	2.100	1.800	.150	.150	1.750
40	55.88	48.26	3.81	3.81	46.99
	2.200	1.900	.150	.150	1.850
42	58.42	50.80	3.81	3.81	49.53
	2.300	2.000	.150	.150	1.950
44	60.96	53.34	3.81	3.81	52.07
	2.400	2.100	.150	.150	2.050
46	63.50	55.88	3.81	3.81	54.61
	2.500	2.200	.150	.150	2.150
48	66.04	58.42	3.81	3.81	57.15
	2.600	2.300	.150	.150	2.250
50	68.58	60.96	3.81	3.81	59.69
	2.700	2.400	.150	.150	2.350
52	71.12	63.50	3.81	3.81	62.23
	2.800	2.500	.150	.150	2.450
54	73.66	66.04	3.81	3.81	64.77
	2.900	2.600	.150	.150	2.550
56	76.20	68.58	3.81	3.81	67.31
	3.000	2.700	.150	.150	2.650
58	78.74	71.12	3.81	3.81	69.85
	3.100	2.800	.150	.150	2.750
60	81.28	73.66	3.81	3.81	72.39
	3.200	2.900	.150	.150	2.850
62	83.82	76.20	3.81	3.81	74.93
	3.300	3.000	.150	.150	2.950
64	86.36	78.74	3.81	3.81	77.47
	3.400	3.100	.150	.150	3.050
66	88.90	81.28	3.81	3.81	80.01
	3.500	3.200	.150	.150	3.150
68	91.44	83.82	3.81	3.81	82.55
	3.600	3.300	.150	.150	3.250
70	93.98	86.36	3.81	3.81	85.09
	3.700	3.400	.150	.150	3.350
72	96.52	88.90	3.81	3.81	87.63
	3.800	3.500	.150	.150	3.450

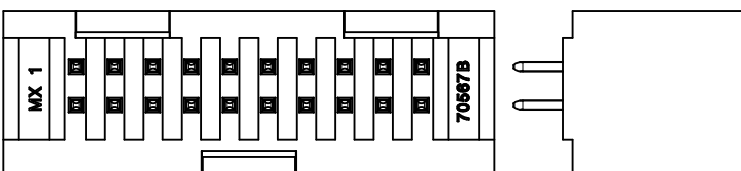

CORRECT PCB HOLE SIZE IEC NO: UCP2011-0294 DRWN:MS BARRA 2010/08/02 CHKD:DWORGAN 1988/03/10 APPR:MBANKIS 2010/08/03	QUALITY SYMBOLS ▽=0 ▽=0 ▽=0	GENERAL TOLERANCES (UNLESS SPECIFIED)		DIMENSION STYLE MM/IN		SCALE 4:1	DESIGN UNITS INCH	THIRD ANGLE PROJECTION			
		mm INCH 4 PLACES ± --- ± --- 3 PLACES ± --- ± .005 2 PLACES ± 0.13 ± .010 1 PLACE ± 0.25 ± --- ANGULAR ± 1/2°		DRAWN BY DATE EIK 1988/03/10 CHECKED BY DATE EIK 1988/03/10 APPROVED BY DATE MILLER 2010/03/31		4 SIDES SHROUDED HEADER HIGH TEMP, (2.54)/.100 GRID W/ (0.64)/.025 PINS MOLEX MOLEX INCORPORATED					
		DRAFT WHERE APPLICABLE MUST REMAIN WITHIN DIMENSIONS		SEE TABLE		MATERIAL NO. DOCUMENT NO. SDA-70567-****		SHEET NO. 2 OF 5			
		THIS DRAWING CONTAINS INFORMATION THAT IS PROPRIETARY TO MOLEX INCORPORATED AND SHOULD NOT BE USED WITHOUT WRITTEN PERMISSION									

20	19	18	17	16	15	14	13	12	11	10	9	8	7	6	5	4	3	2	1
ENGINEERING NUMBER A-70567	MANUFACTURE RELEASE STATUS	E REF.	C ±.015 (0.38)	CONNECTOR END PLATING		P.C. BOARD END PLATING		PACKAGING INFORMATION PK-70873-											
				TYPE	D MEAS.	TYPE	F MEAS.												
-0001/-0034	R.F.M.	.130 (3.30)	.315 (8.00)	TIN	.100 (2.54)	TIN	.050 (1.27)	0018											
-0035/-0068	R.F.M.	.200 (5.08)	.315 (8.00)	TIN	.100 (2.54)	TIN	.050 (1.27)	0018											
-0069/-0102	R.F.M.	.130 (3.30)	.315 (8.00)	15 GOLD	.100 (2.54)	TIN	.050 (1.27)	0018											
-0103/-0136	R.F.M.	.200 (5.08)	.315 (8.00)	15 GOLD	.100 (2.54)	TIN	.050 (1.27)	0018											
-0137/-0170	R.F.M.	.130 (3.30)	.315 (8.00)	30 GOLD	.100 (2.54)	TIN	.050 (1.27)	0018											
-0171/-0204	R.F.M.	.200 (5.08)	.315 (8.00)	30 GOLD	.100 (2.54)	TIN	.050 (1.27)	0018											

NO. OF CKTS	OPTION "A"		OPTION "A"		OPTION "A"		OPTION "A"		OPTION "A"		OPTION "A"								NO. OF CKTS
	EDP NUMBER	ENG NUMBER	EDP NUMBER	ENG NUMBER	EDP NUMBER	ENG NUMBER	EDP NUMBER	ENG NUMBER	EDP NUMBER	ENG NUMBER	EDP NUMBER	ENG NUMBER	EDP NUMBER	ENG NUMBER	EDP NUMBER	ENG NUMBER	EDP NUMBER	ENG NUMBER	
06	15-80-0061	A-70567-0001	70567-0035	A-70567-0035	15-80-0063	A-70567-0069	70567-0103	A-70567-0103	15-80-0065	A-70567-0137	70567-0171	A-70567-0171							06
08	15-80-0081	A-70567-0002	70567-0036	A-70567-0036	15-80-0083	A-70567-0070	70567-0104	A-70567-0104	15-80-0085	A-70567-0138	70567-0172	A-70567-0172							08
10	15-80-0101	A-70567-0003	70567-0037	A-70567-0037	15-80-0103	A-70567-0071	70567-0105	A-70567-0105	15-80-0105	A-70567-0139	70567-0173	A-70567-0173							10
12	15-80-0121	A-70567-0004	70567-0038	A-70567-0038	15-80-0123	A-70567-0072	70567-0106	A-70567-0106	15-80-0125	A-70567-0140	70567-0174	A-70567-0174							12
14	15-80-0141	A-70567-0005	70567-0039	A-70567-0039	15-80-0143	A-70567-0073	70567-0107	A-70567-0107	15-80-0145	A-70567-0141	70567-0175	A-70567-0175							14
16	15-80-0161	A-70567-0006	70567-0040	A-70567-0040	15-80-0163	A-70567-0074	70567-0108	A-70567-0108	15-80-0165	A-70567-0142	70567-0176	A-70567-0176							16
18	15-80-0181	A-70567-0007	70567-0041	A-70567-0041	15-80-0183	A-70567-0075	70567-0109	A-70567-0109	15-80-0185	A-70567-0143	70567-0177	A-70567-0177							18
20	15-80-0201	A-70567-0008	70567-0042	A-70567-0042	15-80-0203	A-70567-0076	70567-0110	A-70567-0110	15-80-0205	A-70567-0144	70567-0178	A-70567-0178							20
22	15-80-0221	A-70567-0009	70567-0043	A-70567-0043	15-80-0223	A-70567-0077	70567-0111	A-70567-0111	15-80-0225	A-70567-0145	70567-0179	A-70567-0179							22
24	15-80-0241	A-70567-0010	70567-0044	A-70567-0044	15-80-0243	A-70567-0078	70567-0112	A-70567-0112	15-80-0245	A-70567-0146	70567-0180	A-70567-0180							24
26	15-80-0261	A-70567-0011	70567-0045	A-70567-0045	15-80-0263	A-70567-0079	70567-0113	A-70567-0113	15-80-0265	A-70567-0147	70567-0181	A-70567-0181							26
28	15-80-0281	A-70567-0012	70567-0046	A-70567-0046	15-80-0283	A-70567-0080	70567-0114	A-70567-0114	15-80-0285	A-70567-0148	70567-0182	A-70567-0182							28
30	15-80-0301	A-70567-0013	70567-0047	A-70567-0047	15-80-0303	A-70567-0081	70567-0115	A-70567-0115	15-80-0305	A-70567-0149	70567-0183	A-70567-0183							30
32	15-80-0321	A-70567-0014	70567-0048	A-70567-0048	15-80-0323	A-70567-0082	70567-0116	A-70567-0116	15-80-0325	A-70567-0150	70567-0184	A-70567-0184							32
34	15-80-0341	A-70567-0015	70567-0049	A-70567-0049	15-80-0343	A-70567-0083	70567-0117	A-70567-0117	15-80-0345	A-70567-0151	70567-0185	A-70567-0185							34
36	15-80-0361	A-70567-0016	70567-0050	A-70567-0050	15-80-0363	A-70567-0084	70567-0118	A-70567-0118	15-80-0365	A-70567-0152	70567-0186	A-70567-0186							36
38	15-80-0381	A-70567-0017	70567-0051	A-70567-0051	15-80-0383	A-70567-0085	70567-0119	A-70567-0119	15-80-0385	A-70567-0153	70567-0187	A-70567-0187							38
40	15-80-0401	A-70567-0018	70567-0052	A-70567-0052	15-80-0403	A-70567-0086	70567-0120	A-70567-0120	15-80-0405	A-70567-0154	70567-0188	A-70567-0188							40
42	15-80-0421	A-70567-0019	70567-0053	A-70567-0053	15-80-0423	A-70567-0087	70567-0121	A-70567-0121	15-80-0425	A-70567-0155	70567-0189	A-70567-0189							42
44	15-80-0441	A-70567-0020	70567-0054	A-70567-0054	15-80-0443	A-70567-0088	70567-0122	A-70567-0122	15-80-0445	A-70567-0156	70567-0190	A-70567-0190							44
46	15-80-0461	A-70567-0021	70567-0055	A-70567-0055	15-80-0463	A-70567-0089	70567-0123	A-70567-0123	15-80-0465	A-70567-0157	70567-0191	A-70567-0191							46
48	15-80-0481	A-70567-0022	70567-0056	A-70567-0056	15-80-0483	A-70567-0090	70567-0124	A-70567-0124	15-80-0485	A-70567-0158	70567-0192	A-70567-0192							48
50	15-80-0501	A-70567-0023	70567-0057	A-70567-0057	15-80-0503	A-70567-0091	70567-0125	A-70567-0125	15-80-0505	A-70567-0159	70567-0193	A-70567-0193							50
52	15-80-0521	A-70567-0024	70567-0058	A-70567-0058	15-80-0523	A-70567-0092	70567-0126	A-70567-0126	15-80-0525	A-70567-0160	70567-0194	A-70567-0194							52
54	15-80-0541	A-70567-0025	70567-0059	A-70567-0059	15-80-0543	A-70567-0093	70567-0127	A-70567-0127	15-80-0545	A-70567-0161	70567-0195	A-70567-0195							54
56	15-80-0561	A-70567-0026	70567-0060	A-70567-0060	15-80-0563	A-70567-0094	70567-0128	A-70567-0128	15-80-0565	A-70567-0162	70567-0196	A-70567-0196							56
58	15-80-0581	A-70567-0027	70567-0061	A-70567-0061	15-80-0583	A-70567-0095	70567-0129	A-70567-0129	15-80-0585	A-70567-0163	70567-0197	A-70567-0197							58
60	15-80-0601	A-70567-0028	70567-0062	A-70567-0062	15-80-0603	A-70567-0096	70567-0130	A-70567-0130	15-80-0605	A-70567-0164	70567-0198	A-70567-0198							60
62	15-80-0621	A-70567-0029	70567-0063	A-70567-0063	15-80-0623	A-70567-0097	70567-0131	A-70567-0131	15-80-0625	A-70567-0165	70567-0199	A-70567-0199							62
64	15-80-0641	A-70567-0030	70567-0064	A-70567-0064	15-80-0643	A-70567-0098	70567-0132	A-70567-0132	15-80-0645	A-70567-0166	70567-0200	A-70567-0200							64
66	15-80-0661	A-70567-0031	70567-0065	A-70567-0065	15-80-0663	A-70567-0099	70567-0133	A-70567-0133	15-80-0665	A-70567-0167	70567-0201	A-70567-0201							66
68	15-80-0681	A-70567-0032	70567-0066	A-70567-0066	15-80-0683	A-70567-0100	70567-0134	A-70567-0134	15-80-0685	A-70567-0168	70567-0202	A-70567-0202							68
70	15-80-0701	A-70567-0033	70567-0067	A-70567-0067	15-80-0703	A-70567-0101	70567-0135	A-70567-0135	15-80-0705	A-70567-0169	70567-0203	A-70567-0203							70
72	15-80-0721	A-70567-0034	70567-0068	A-70567-0068	15-80-0723	A-70567-0102	70567-0136	A-70567-0136	15-80-0725	A-70567-0170	70567-0204	A-70567-0204							72

SEE SHEETS 1 & 2 EC NO: UCP2011-0294 DRAWN BY: BARBA 2010/08/02 CHKD BY: MORGAN 1988/03/10 APPR BY: HAWKINS 2010/08/03	QUALITY SYMBOLS ∇=0 ∇=0 ∇=0	GENERAL TOLERANCES (UNLESS SPECIFIED) <table border="1"> <tr><th></th><th>mm</th><th>INCH</th></tr> <tr><td>4 PLACES ±</td><td>---</td><td>---</td></tr> <tr><td>3 PLACES ±</td><td>+.005</td><td>±.010</td></tr> <tr><td>2 PLACES ±</td><td>0.13</td><td>±.010</td></tr> <tr><td>1 PLACE ±</td><td>0.25</td><td>±---</td></tr> </table> ANGULAR ±1/2°		mm	INCH	4 PLACES ±	---	---	3 PLACES ±	+.005	±.010	2 PLACES ±	0.13	±.010	1 PLACE ±	0.25	±---	DIMENSION STYLE MM/IN DRAWN BY: DATE EIK 1988/03/10 CHECKED BY: DATE EIK 1988/03/10 APPROVED BY: DATE SMILLER 2010/03/31	SCALE 1:1 DESIGN UNITS INCH THIRD ANGLE PROJECTION	TITLE 4 SIDES SHROUDED HEADER HIGH TEMP. (2.54)/.100 GRID W/ (.064)/.025 PINS	MATERIAL NO. SEE TABLE	DOCUMENT NO. SDA-70567-****	SHEET NO. 3 OF 5
		mm	INCH																				
	4 PLACES ±	---	---																				
	3 PLACES ±	+.005	±.010																				
2 PLACES ±	0.13	±.010																					
1 PLACE ±	0.25	±---																					
DRAFT WHERE APPLICABLE MUST REMAIN WITHIN DIMENSIONS																							
THIS DRAWING CONTAINS INFORMATION THAT IS PROPRIETARY TO MOLEX INCORPORATED AND SHOULD NOT BE USED WITHOUT WRITTEN PERMISSION																							
MOLEX INCORPORATED																							

ENGINEERING NUMBER A-70567	MANUFACTURE RELEASE STATUS	E REF.	C ±.015 (0.38)	CONNECTOR END PLATING			P.C. BOARD END PLATING			PACKAGING INFORMATION PK-70873-
				TYPE	D MEAS.	TYPE	F MEAS.			
-0205/-0238	R.F.M.	.130 (3.30)	.315 (8.00)	TIN	.100 (2.54)	TIN	.050 (1.27)	0018		
-0239/-0272	R.F.M.	.200 (5.08)	.315 (8.00)	TIN	.100 (2.54)	TIN	.050 (1.27)	0018		
-0273/-0306	R.F.M.	.130 (3.30)	.315 (8.00)	15 GOLD	.100 (2.54)	TIN	.050 (1.27)	0018		
-0307/-0340	R.F.M.	.200 (5.08)	.315 (8.00)	15 GOLD	.100 (2.54)	TIN	.050 (1.27)	0018		
-0341/-0374	R.F.M.	.130 (3.30)	.315 (8.00)	30 GOLD	.100 (2.54)	TIN	.050 (1.27)	0018		
-0375/-0408	R.F.M.	.200 (5.08)	.315 (8.00)	30 GOLD	.100 (2.54)	TIN	.050 (1.27)	0018		

NO. OF CKTS	OPTION "B"		OPTION "B"		OPTION "B"		OPTION "B"		OPTION "B"		OPTION "B"						NO. OF CKTS
	EDP NUMBER	ENG NUMBER	EDP NUMBER	ENG NUMBER	EDP NUMBER	ENG NUMBER	EDP NUMBER	ENG NUMBER	EDP NUMBER	ENG NUMBER	EDP NUMBER	ENG NUMBER	EDP NUMBER	ENG NUMBER	EDP NUMBER	ENG NUMBER	
06	IS-80-0067	A-70567-0205	70567-0239	A-70567-0239	IS-80-0069	A-70567-0273	70567-0307	A-70567-0307	IS-80-1061	A-70567-0341	70567-0375	A-70567-0375					06
08	IS-80-0087	A-70567-0206	70567-0240	A-70567-0240	IS-80-0089	A-70567-0274	70567-0308	A-70567-0308	IS-80-1081	A-70567-0342	70567-0376	A-70567-0376					08
10	IS-80-0107	A-70567-0207	70567-0241	A-70567-0241	IS-80-0109	A-70567-0275	70567-0309	A-70567-0309	IS-80-1101	A-70567-0343	70567-0377	A-70567-0377					10
12	IS-80-0127	A-70567-0208	70567-0242	A-70567-0242	IS-80-0129	A-70567-0276	70567-0310	A-70567-0310	IS-80-1121	A-70567-0344	70567-0378	A-70567-0378					12
14	IS-80-0147	A-70567-0209	70567-0243	A-70567-0243	IS-80-0149	A-70567-0277	70567-0311	A-70567-0311	IS-80-1141	A-70567-0345	70567-0379	A-70567-0379					14
16	IS-80-0167	A-70567-0210	70567-0244	A-70567-0244	IS-80-0169	A-70567-0278	70567-0312	A-70567-0312	IS-80-1161	A-70567-0346	70567-0380	A-70567-0380					16
18	IS-80-0187	A-70567-0211	70567-0245	A-70567-0245	IS-80-0189	A-70567-0279	70567-0313	A-70567-0313	IS-80-1181	A-70567-0347	70567-0381	A-70567-0381					18
20	IS-80-0207	A-70567-0212	70567-0246	A-70567-0246	IS-80-0209	A-70567-0280	70567-0314	A-70567-0314	IS-80-1201	A-70567-0348	70567-0382	A-70567-0382					20
22	IS-80-0227	A-70567-0213	70567-0247	A-70567-0247	IS-80-0229	A-70567-0281	70567-0315	A-70567-0315	IS-80-1221	A-70567-0349	70567-0383	A-70567-0383					22
24	IS-80-0247	A-70567-0214	70567-0248	A-70567-0248	IS-80-0249	A-70567-0282	70567-0316	A-70567-0316	IS-80-1241	A-70567-0350	70567-0384	A-70567-0384					24
26	IS-80-0267	A-70567-0215	70567-0249	A-70567-0249	IS-80-0269	A-70567-0283	70567-0317	A-70567-0317	IS-80-1261	A-70567-0351	70567-0385	A-70567-0385					26
28	IS-80-0287	A-70567-0216	70567-0250	A-70567-0250	IS-80-0289	A-70567-0284	70567-0318	A-70567-0318	IS-80-1281	A-70567-0352	70567-0386	A-70567-0386					28
30	IS-80-0307	A-70567-0217	70567-0251	A-70567-0251	IS-80-0309	A-70567-0285	70567-0319	A-70567-0319	IS-80-1301	A-70567-0353	70567-0387	A-70567-0387					30
32	IS-80-0327	A-70567-0218	70567-0252	A-70567-0252	IS-80-0329	A-70567-0286	70567-0320	A-70567-0320	IS-80-1321	A-70567-0354	70567-0388	A-70567-0388					32
34	IS-80-0347	A-70567-0219	70567-0253	A-70567-0253	IS-80-0349	A-70567-0287	70567-0321	A-70567-0321	IS-80-1341	A-70567-0355	70567-0389	A-70567-0389					34
36	IS-80-0367	A-70567-0220	70567-0254	A-70567-0254	IS-80-0369	A-70567-0288	70567-0322	A-70567-0322	IS-80-1361	A-70567-0356	70567-0390	A-70567-0390					36
38	IS-80-0387	A-70567-0221	70567-0255	A-70567-0255	IS-80-0389	A-70567-0289	70567-0323	A-70567-0323	IS-80-1381	A-70567-0357	70567-0391	A-70567-0391					38
40	IS-80-0407	A-70567-0222	70567-0256	A-70567-0256	IS-80-0409	A-70567-0290	70567-0324	A-70567-0324	IS-80-1401	A-70567-0358	70567-0392	A-70567-0392					40
42	IS-80-0427	A-70567-0223	70567-0257	A-70567-0257	IS-80-0429	A-70567-0291	70567-0325	A-70567-0325	IS-80-1421	A-70567-0359	70567-0393	A-70567-0393					42
44	IS-80-0447	A-70567-0224	70567-0258	A-70567-0258	IS-80-0449	A-70567-0292	70567-0326	A-70567-0326	IS-80-1441	A-70567-0360	70567-0394	A-70567-0394					44
46	IS-80-0467	A-70567-0225	70567-0259	A-70567-0259	IS-80-0469	A-70567-0293	70567-0327	A-70567-0327	IS-80-1461	A-70567-0361	70567-0395	A-70567-0395					46
48	IS-80-0487	A-70567-0226	70567-0260	A-70567-0260	IS-80-0489	A-70567-0294	70567-0328	A-70567-0328	IS-80-1481	A-70567-0362	70567-0396	A-70567-0396					48
50	IS-80-0507	A-70567-0227	70567-0261	A-70567-0261	IS-80-0509	A-70567-0295	70567-0329	A-70567-0329	IS-80-1501	A-70567-0363	70567-0397	A-70567-0397					50
52	IS-80-0527	A-70567-0228	70567-0262	A-70567-0262	IS-80-0529	A-70567-0296	70567-0330	A-70567-0330	IS-80-1521	A-70567-0364	70567-0398	A-70567-0398					52
54	IS-80-0547	A-70567-0229	70567-0263	A-70567-0263	IS-80-0549	A-70567-0297	70567-0331	A-70567-0331	IS-80-1541	A-70567-0365	70567-0399	A-70567-0399					54
56	IS-80-0567	A-70567-0230	70567-0264	A-70567-0264	IS-80-0569	A-70567-0298	70567-0332	A-70567-0332	IS-80-1561	A-70567-0366	70567-0400	A-70567-0400					56
58	IS-80-0587	A-70567-0231	70567-0265	A-70567-0265	IS-80-0589	A-70567-0299	70567-0333	A-70567-0333	IS-80-1581	A-70567-0367	70567-0401	A-70567-0401					58
60	IS-80-0607	A-70567-0232	70567-0266	A-70567-0266	IS-80-0609	A-70567-0300	70567-0334	A-70567-0334	IS-80-1601	A-70567-0368	70567-0402	A-70567-0402					60
62	IS-80-0627	A-70567-0233	70567-0267	A-70567-0267	IS-80-0629	A-70567-0301	70567-0335	A-70567-0335	IS-80-1621	A-70567-0369	70567-0403	A-70567-0403					62
64	IS-80-0647	A-70567-0234	70567-0268	A-70567-0268	IS-80-0649	A-70567-0302	70567-0336	A-70567-0336	IS-80-1641	A-70567-0370	70567-0404	A-70567-0404					64
66	IS-80-0667	A-70567-0235	70567-0269	A-70567-0269	IS-80-0669	A-70567-0303	70567-0337	A-70567-0337	IS-80-1661	A-70567-0371	70567-0405	A-70567-0405					66
68	IS-80-0687	A-70567-0236	70567-0270	A-70567-0270	IS-80-0689	A-70567-0304	70567-0338	A-70567-0338	IS-80-1681	A-70567-0372	70567-0406	A-70567-0406					68
70	IS-80-0707	A-70567-0237	70567-0271	A-70567-0271	IS-80-0709	A-70567-0305	70567-0339	A-70567-0339	IS-80-1701	A-70567-0373	70567-0407	A-70567-0407					70
72	IS-80-0727	A-70567-0238	70567-0272	A-70567-0272	IS-80-0729	A-70567-0306	70567-0340	A-70567-0340	IS-80-1721	A-70567-0374	70567-0408	A-70567-0408					72

SEE SHEETS 1 & 2 EC NO: UCT2011-0294 DRAWN(S) BARRA CHKD(MORGAN) APPR(MEAWAKS) DATE: 2010/03/10	QUALITY SYMBOLS ∇=0 ∇=0 ∇=0	GENERAL TOLERANCES (UNLESS SPECIFIED) mm INCH		DIMENSION STYLE MM/IN		SCALE 1:1		DESIGN UNITS INCH		THIRD ANGLE PROJECTION	
		4 PLACES ±.005 ±.005 3 PLACES ±.010 ±.010 2 PLACES ±.015 ±.015 1 PLACE ±.025 ±.025		DRAWN BY DATE EIK 1988/03/10		CHECKED BY DATE EIK 1988/03/10		APPROVED BY DATE MILLER 2010/03/31		TITLE 4 SIDES SHROUDED HEADER HIGH TEMP. (2.54)/100 GRID W/ (0.64)/0.25 PINS	
		ANGULAR ±1/2°		MATERIAL NO. SEE TABLE		DOCUMENT NO. SDA-70567-****		SHEET NO. 4 OF 5		MOLEX INCORPORATED	
		DRAFT WHERE APPLICABLE MUST REMAIN WITHIN DIMENSIONS		THIS DRAWING CONTAINS INFORMATION THAT IS PROPRIETARY TO MOLEX INCORPORATED AND SHOULD NOT BE USED WITHOUT WRITTEN PERMISSION							

SPECIAL - WITH VOIDS

CKTS SIZE	ENGINEERING NUMBER A-70567	EDP NUMBER	E REF.	C $\pm \frac{.015}{(0.38)}$	K $\pm \frac{.015}{(0.38)}$	VOID CKTS	CONNECTOR END PLATING		P.C. BOARD END PLATING		PACKAGING INFORMATION PK-70873-
							TYPE	D MEAS.	TYPE	F MEAS.	
10	-9003	70567-9003	.130 (3.30)	.315 (8.00)	.415 (10.54)	10	GOLD	.100 (2.54)	TIN	.050 (.127)	0018

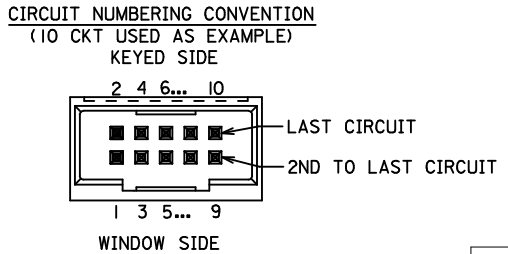

SEE SHEETS 1 & 2 EC NO: UCP2011-0294 DRWN:MSIBARRA 2010/08/02 CHKD:DMORGAN 1988/03/10 APPR:MBANKIS 2010/08/03	QUALITY SYMBOLS 	GENERAL TOLERANCES (UNLESS SPECIFIED) <table border="1"> <tr> <th></th> <th>mm</th> <th>INCH</th> </tr> <tr> <td>4 PLACES</td> <td>± .---</td> <td>± .---</td> </tr> <tr> <td>3 PLACES</td> <td>± .---</td> <td>± .005</td> </tr> <tr> <td>2 PLACES</td> <td>± 0.13</td> <td>± .010</td> </tr> <tr> <td>1 PLACE</td> <td>± 0.25</td> <td>± .---</td> </tr> </table>		mm	INCH	4 PLACES	± .---	± .---	3 PLACES	± .---	± .005	2 PLACES	± 0.13	± .010	1 PLACE	± 0.25	± .---	DIMENSION STYLE MM/IN DRAWN BY DATE EIK 1988/03/10 CHECKED BY DATE EIK 1988/03/10 APPROVED BY DATE MILLER 2010/03/31	SCALE 4:1 DESIGN UNITS INCH THIRD ANGLE PROJECTION	TITLE 4 SIDES SHROUDED HEADER HIGH TEMP. (2.54)/.100 GRID W/ (.64)/.025 PINS
		mm	INCH																	
	4 PLACES	± .---	± .---																	
	3 PLACES	± .---	± .005																	
	2 PLACES	± 0.13	± .010																	
1 PLACE	± 0.25	± .---																		
		ANGULAR ±1/2° DRAFT WHERE APPLICABLE MUST REMAIN WITHIN DIMENSIONS	MATERIAL NO. SEE TABLE SIZE THIS DRAWING CONTAINS INFORMATION THAT IS PROPRIETARY TO MOLEX INCORPORATED AND SHOULD NOT BE USED WITHOUT WRITTEN PERMISSION	MOLEX INCORPORATED DOCUMENT NO. SDA-70567-**** SHEET NO. 5 OF 5																



Компания «ЭлектроПласт» предлагает заключение долгосрочных отношений при поставках импортных электронных компонентов на взаимовыгодных условиях!

Наши преимущества:

- Оперативные поставки широкого спектра электронных компонентов отечественного и импортного производства напрямую от производителей и с крупнейших мировых складов;
- Поставка более 17-ти миллионов наименований электронных компонентов;
- Поставка сложных, дефицитных, либо снятых с производства позиций;
- Оперативные сроки поставки под заказ (от 5 рабочих дней);
- Экспресс доставка в любую точку России;
- Техническая поддержка проекта, помощь в подборе аналогов, поставка прототипов;
- Система менеджмента качества сертифицирована по Международному стандарту ISO 9001;
- Лицензия ФСБ на осуществление работ с использованием сведений, составляющих государственную тайну;
- Поставка специализированных компонентов (Xilinx, Altera, Analog Devices, Intersil, Interpoint, Microsemi, Aeroflex, Peregrine, Syfer, Eurofarad, Texas Instrument, Miteq, Cobham, E2V, MA-COM, Hittite, Mini-Circuits, General Dynamics и др.);

Помимо этого, одним из направлений компании «ЭлектроПласт» является направление «Источники питания». Мы предлагаем Вам помощь Конструкторского отдела:

- Подбор оптимального решения, техническое обоснование при выборе компонента;
- Подбор аналогов;
- Консультации по применению компонента;
- Поставка образцов и прототипов;
- Техническая поддержка проекта;
- Защита от снятия компонента с производства.



Как с нами связаться

Телефон: 8 (812) 309 58 32 (многоканальный)

Факс: 8 (812) 320-02-42

Электронная почта: org@eplast1.ru

Адрес: 198099, г. Санкт-Петербург, ул. Калинина, дом 2, корпус 4, литера А.