



# FTR-J2 Series

## ■ Specifications (1/2)

Item	FTR-J2		Remarks / conditions	
Contact data	Configuration		1 form A x 2	
	Material		Silver alloy	
	Resistance		Max. 100mΩ	at 1A, 6VDC between contact terminals Note1
	Contact rating	10A, 450VDC (resistive load)		When 2 contacts connected in series through a common load
		10A, 200VDC (resistive load)		When each NO contact is used independently
	Overload switching	10A, 500VDC (resistive load) 50 ops.		When 2 contacts connected in series through a common load
		10A, 250VDC (resistive load) 50 ops.		When each NO contact is used independently
	Max. carrying current		12A per contact	2 contacts connected in series through a common load is counted as 1 contact Note2
	Inrush current		Peak 150A per contact	2 contacts connected in series through a common load is counted as 1 contact Note2
	Max. switching voltage	600VDC		When 2 contacts connected in series through a common load
300VDC		When each NO contact is used independently		
Contact voltage drop (initial)		Max. 0.1V per contact	At 10A, between contact terminals Note1	
Minimum switching load (reference * )		100mA 5VDC per contact	2 contacts connected in series through a common load is counted as 1 contact Note2	
Coil	Rated power		530mW	Standard single coil at 20°C (Please refer to Coil Rating for 2 coils)
	Operate voltage		Maximum 70% of nominal voltage	At 20°C
	Release voltage		Maximum 5% of nominal voltage	At 20°C
	Operating temperature range		-40°C ~ +85°C	No frost Note3
Timing data	Operate		Max. 15ms (without bounce)	At nominal voltage, 20°C, with varistor
	Release		Max. 5ms (without bounce)	
Life	Mechanical		Min. 2M operations per contact	2 contacts connected in series through a common load is counted as 1 contact Note2
	Electrical		Min. 10K operations per contact	2 contacts connected in series through a common load is counted as 1 contact Note2
Insulation	Insulation resistance (initial)		Min. 1000MΩ at 500VDC	
	Dielectric strength	Open contacts	1000VAC (50/60Hz), 1 minute Note2	
		Adjacent contact	1000VAC (50/60Hz), 1 minute Note1	
		Coil contacts	4000VAC (50/60Hz), 1 minute Note1	
Surge strength	Coil to contacts	10000V / 1.2 x 50μm standard wave Note2		

# FTR-J2 Series

## ■ Specifications (2/2)

Other	Vibration resistance	Misoperation	10Hz ~ 55Hz ~ 10Hz single amplitude 0.75mm	Coil ON/OFF, 3 axes, total 6 cycles
		Endurance	10Hz ~ 55Hz ~ 10Hz single amplitude 0.75mm	Coil OFF, 3 axes, total 6 hours
	Shock resistance	Misoperation	Min. 200m/s <sup>2</sup> (11 ± 1ms)	Coil ON/OFF, 3 axes, total 36 operations
		Endurance	Min. 1,000m/s <sup>2</sup> (6 ± 1ms)	Coil OFF, 3 axes, total 18 operations
	Dimensions / weight		23.5 x 24.0 x 27.0 mm / approx. 26g	
	Sealing		Flux proof RTII	

Values of electrical characteristics are under 15 to 35 degC, 25 to 75%RH, air pressure 86kPa to 106kPa (JIS standard condition) unless otherwise specified.

\* Minimum switching loads mentioned above are reference values. Please perform the confirmation test with actual load before production since reference values may vary according to switching frequencies, environmental conditions and expected reliability levels.

Note 1: The specification value is applied to each contact in case 2 coils are connected in series through a common load.

Note 2: The contacts connected in series are considered as an integrated contact in case 2 coils are connected in series through a common load.

Note 3: There are cases where the relay does not operate when it is used at high ambient temperature. Please refer to characteristic data and apply adequate coil voltage.

**!** There would be a possibility that high voltage DC relay loses breaking current ability as one of failure modes.  
Please provide fail safeness design on the circuit. To secure safety, the relay shall not be used in exceeding its specifications including operation life, and handle the relay as a periodic maintenance component.

**!** Relay contact terminals have polarity. Please connect higher potential side of the load to (+). Please refer to recommended circuit layout.

**!** Please always use a varistor to protect the coil from back electromotive force. Use of other protection element may shorten relay life excessively.

**!** Varistor shall be connected in parallel to the relay coil.  
Please refer to recommended circuit layout.  
Varistor voltage shall have 3 times as high as applied coil voltage.

**!** Care shall be taken on the heat generated on PC board when maximum carrying current exceeds 10A. Please perform the confirmation test with actual conditions.

# FTR-J2 Series

## ■ Coil Data

Standard single coil

Coil code	Rated Coil Voltage (VDC)	Coil Resistance +/-10% ( $\Omega$ )	Must Operate Voltage* (VDC)	Must Release Voltage* (VDC)	Rated Power (W) ( $\pm 10\%$ )
005	5	47	3.5	0.25	Approx. 0.53
006	6	68	4.2	0.3	
012	12	270	8.4	0.6	
024	24	1,100	16.8	1.2	
048	48	4,400	33.6	2.4	
060	60	6,790	42.0	3	
110	110	22,800	77.0	5.5	

2 coils in series (Connect relay coil terminal No.2 to No.3) See note 2.

Coil code	Rated Coil Voltage (VDC)	Coil Resistance +/-10% ( $\Omega$ )	Must Operate Voltage* (VDC)	Must Release Voltage* (VDC)	Rated Power (W) ( $\pm 10\%$ )
005	10	94	7.0	0.5	1.06
006	12	136	8.4	0.6	
012	24	540	16.8	1.2	
024	48	2,200	33.6	2.4	
048	96	8,800	67.2	4.8	
060	120	13,580	84	6	
110	220	45,600	154	11	

2 coils in parallel (Connect relay coil terminal No.1 to No.3 and No.2 to No.4)

Coil code	Rated Coil Voltage (VDC)	Coil Resistance +/-10% ( $\Omega$ )	Must Operate Voltage* (VDC)	Must Release Voltage* (VDC)	Rated Power (W) ( $\pm 10\%$ )
005	5	23.5	3.5	0.25	1.06
006	6	34	4.2	0.3	
012	12	135	8.4	0.6	
024	24	550	16.8	1.2	
048	48	2,200	33.6	2.4	
060	60	3,395	42.0	3	
110	110	11,400	77.0	5.5	

Note 1: All values in the tables are valid for 20°C and zero contact current.

Note 2: Nominal voltage is different from indication of part number

Note 3: Please use at rated coil voltage. Please refer to characteristic data and set up adequate voltage in case of use at over voltage.

\* Specified operate values are valid for pulse wave voltage.

## ■ Safety Standards

Type	Compliance	Contact rating
UL	UL 508 File No. E63615	10A, 450VDC, resistive, 10,000 cycles for series connection of each NO contact. 10A, 400VDC, resistive, 10,000 cycles for series connection of each NO contact. 10A, 200VDC, resistive, 10,000 cycles for each NO contact.
VDE	IEC/EN61810-1	10A, 400VDC, resistive, 10,000 cycles for series connection of each NO contact. 10A, 200VDC, resistive, 10,000 cycles for each NO contact

# FTR-J2 Series

## ■ Characteristic Data (Reference)

\* Characteristic data is not a guaranteed value, but measured values of samples from production line.

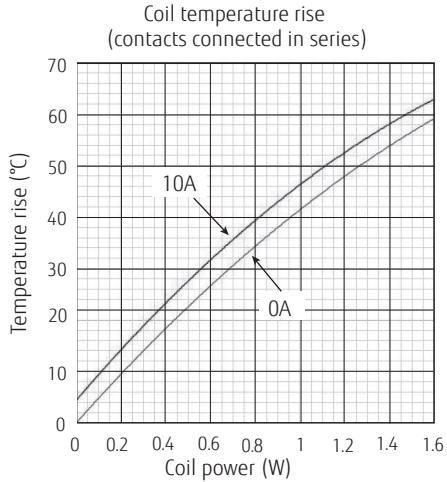

Note: When each contact is used independently, above graph shall be read; same voltage is applied on 2 coils, coil power is sum of 2 coils, applied current 10A is 10A apply on each contact set.

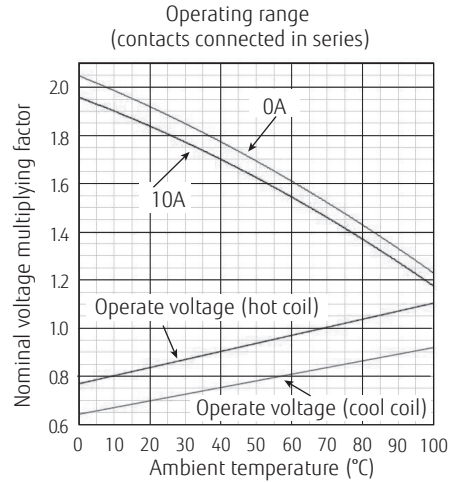

Note: When each contact is used independently, above graph shall be read; same voltage is applied on 2 coils, applied current 10A is 10A apply on each contact set.

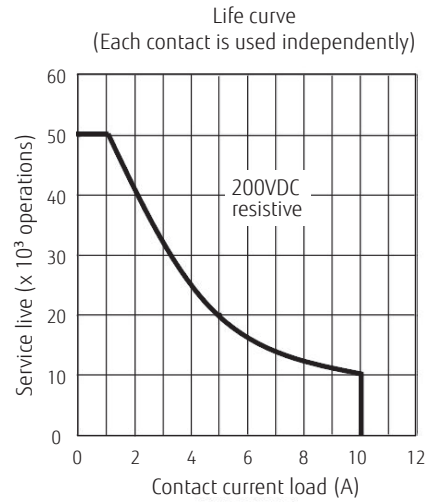
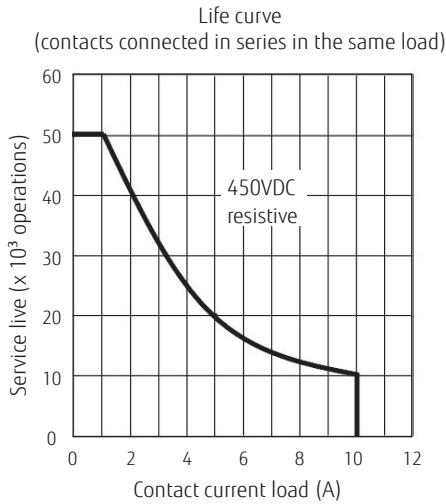

# FTR-J2 Series

## ■ Dimensions

- Dimensions

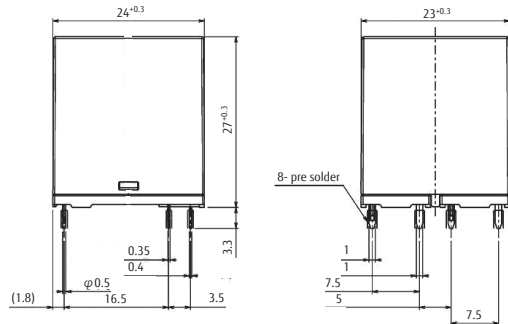

\* Dimensions of the terminals do not include thickness of pre-solder.

- Schematics  
(BOTTOM VIEW)

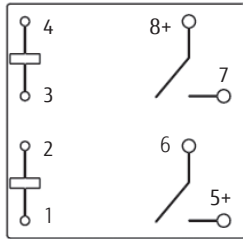

Relay contact terminals have polarity.  
Please connect higher potential side of the load to (+).  
Please always use a varistor to protect the coil from back electromotive force.  
Use of other protection element may shorten relay life excessively. Varistor must connect in parallel to the relay coil.  
Please refer to Recommended Circuit.

- PC Board Mounting Hole Layout  
(BOTTOM VIEW)

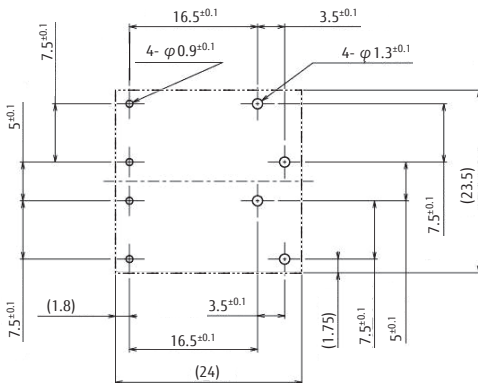

( ): Reference value

Unit: mm

\* Tolerance of PC board mounting hole layout : ±0.1 unless otherwise specified.

# FTR-J2 Series

## ■ Circuit

### ■ Recommended Circuit (2 contacts connected in series under the same common load)

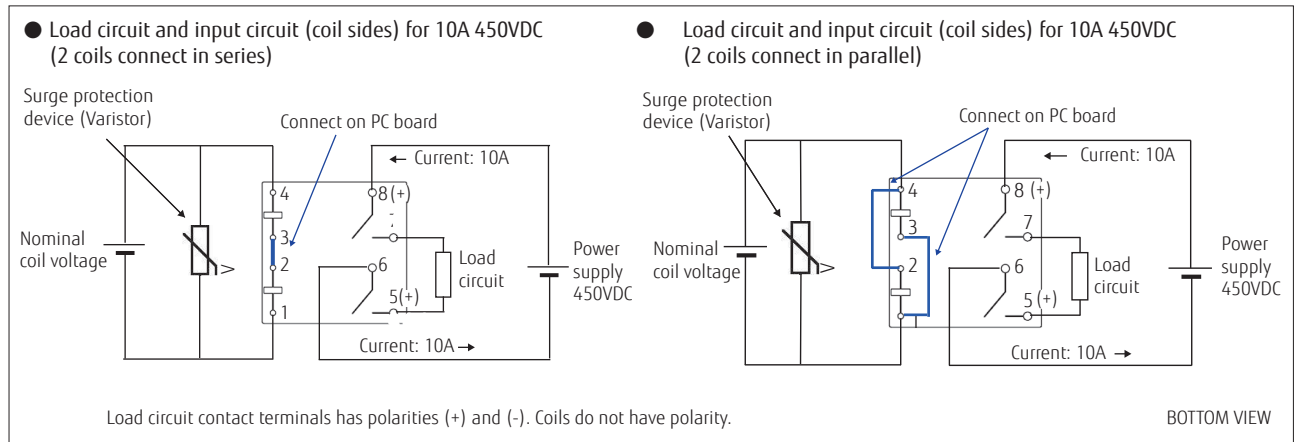

### ■ Recommended Circuit (each contact is used independently)

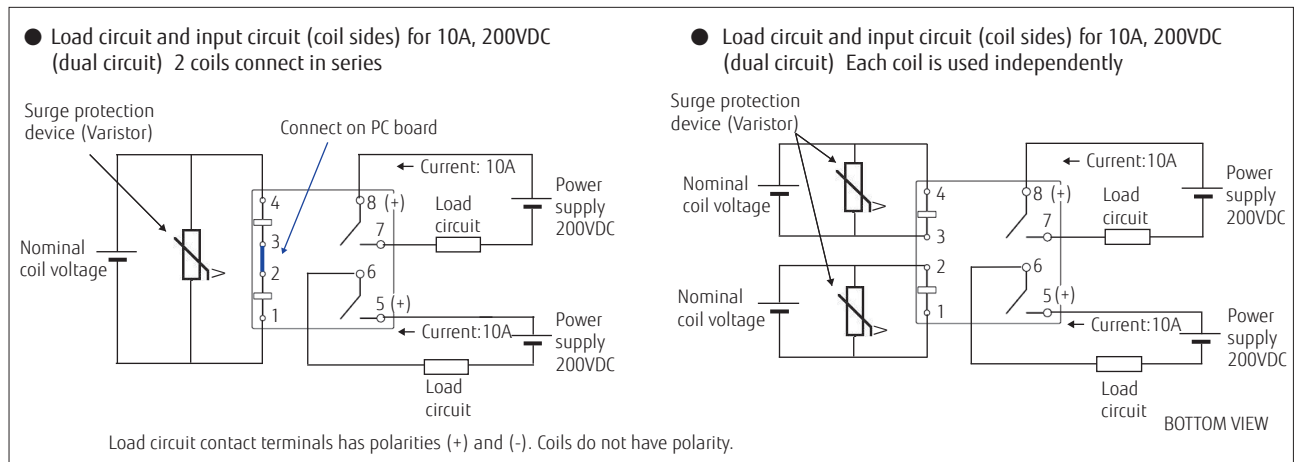

Note 1: In case 2 coils are connected in series, connect coil terminal #2 to #3 on PCB circuit. In case 2 coils are connected in parallel, connect coil terminal #1 to #3 and connect coil terminal #2 to #4 on PCB. Regarding terminal number, refer to schematics data.

Note 2: Please use varistor as surge protection device. If varistor will not be used, the electrical life need to be derated.

Note 3: Varistor surge protection device should be connect parallel to coil(s). Suitable voltage of varistor is 3 times the coil voltage.

Note 4: For max. contact life and correct functioning of the relay, positive polarity of load should be connected to pin 8 and pin 5. If not, damage to the relay can occur.

**!** Warning: At current loads at max. switching capacity 10A (200VDC) correct polarity is vital for the correct and safe functioning of the relay

# FTR-J2 Series

## ■ WARNING



We highly recommend to use the circuit layouts on this datasheet to switch 10A 450VDC or 10A 200VDC.

Polarity of the terminals shall be kept as specified, otherwise fire or electric shock may occur. There would be a possibility that high voltage DC relay loses breaking current ability as one of failure modes. Please provide fail safeness design on the circuit not to result in any injury or deaths or damages. To secure safety, the relay shall not be used in exceeding its specifications including operation life, and handle the relay as a periodic maintenance component.

## ■ Caution

- ! Each coil shall be synchronized completely in case 2 coils are used separately at 10A 450VDC switching. Incomplete synchronization may shorten relay life excessively.
- ! Magnetic field is generated on the top surface of relay. Please consider its influence to other components. When 2 or more relays are mounted quite closely, please confirm operation before actual use.
- ! All values mentioned in this datasheet are provided under ideal conditions. Please perform the confirmation test before actual use.
- ! Reflow soldering is prohibited
- ! Do not use FTR-J2 relays for automotive applications.
- ! Do not use relays in the atmosphere with sulfide gas, chloride gas or nitric oxide. Contact resistance may increase.
- ! Do not use silicon or silicon-containing product or materials near relays. It may cause contact failure.



# FTR-J2 Series

## GENERAL INFORMATION

### 1. ROHS Compliance

- All relays produced by Fujitsu Components are compliant with RoHS directive 2011/65/EU including amendments.
- Use of Cadmium in electrical contacts is exempted as per Annex III of the RoHS directive 2011/65/EU. Please consider expiry date of exemption. Relays with Cadmium containing contacts are not to be used for new designs.
- All relays are lead-free. Please refer to Lead-Free Status Info for older date codes at: <http://www.fujitsu.com/downloads/MICRO/fcai/relays/lead-free-letter.pdf>
- Characteristic data is not guaranteed values, but measured values of samples from production line.

### 2. Recommended lead free solder condition

- Lead free solder plating on relay terminals is Sn-3.0Ag-0.5Cu, unless otherwise specified. This material has been verified to be compatible with PbSn assembly process.
- Recommended solder for assembly: Sn-3.0Ag-0.5Cu.

#### Flow Solder Condition:

Pre-Heating: maximum 120°C  
within 90 sec.  
Soldering: dip within 5 sec. at  
255°C ± 5°C solder bath  
Relay must be cooled by air immediately  
after soldering

#### Solder by Soldering Iron:

Soldering Iron: 30-60W  
Temperature: maximum 350-360°C  
Duration: maximum 3 sec.

**We highly recommend that you confirm your actual solder conditions**

### 3. Moisture Sensitivity

- Moisture Sensitivity Level standard is not applicable to electromechanical relays, unless otherwise indicated.

### 4. Tin Whiskers

- Dipped SnAgCu solder is known as presenting a low risk to tin whisker development. No considerable length whisker was found by our in house test.

# FTR-J2 Series

## Fujitsu Components International Headquarter Offices

<b>Japan</b> FUJITSU COMPONENT LIMITED Shinagawa Seaside Park Tower 19F, 12-4, Higashi-shinagawa 4-chome, Shinagawa-ku, Tokyo, 140-0002, Japan Tel: (81-3) 3450-1682 Fax: (81-3) 3474-2385 Email: fcl-contact@cs.jp.fujitsu.com Web: www.fujitsu.com/jp/fcl/	<b>Asia Pacific</b> FUJITSU COMPONENTS ASIA, LTD. 102E Pasir Panjang Road #01-01 Citilink Warehouse Complex Singapore 118529 Tel: (65) 6375-8560 Fax: (65) 6273-3021 Email: fcal@sg.fujitsu.com Web: www.fujitsu.com/sg/products/devices/components	<b>Korea</b> FUJITSU COMPONENTS KOREA LIMITED Alpha Tower #403, 645 Samsyeong-dong, Bundang-gu, Seongnam-si, Gyeonggi-do, 13524 Korea Tel: (82) 31-708-7108 Fax: (82) 31-709-7108 Email: fcal@sg.fujitsu.com www.fujitsu.com/sg/products/devices/components/
<b>North and South America</b> FUJITSU COMPONENTS AMERICA, INC 2290 North First Street, Suite 212 San Jose, CA 95131, USA Tel: (1-408) 745-4900 Fax: (1-408) 745-4970 Email: components@us.fujitsu.com Web: us.fujitsu.com/components	<b>China</b> FUJITSU ELECTRONIC COMPONENTS (SHANGHAI) CO., LTD. Unit 4306, InterContinental Center 100 Yu Tong Road, Shanghai 200070, China Tel: (86-21) 3253 0998 Fax: (86-21) 3253 0997 Email: fcal@sg.fujitsu.com Web: www.fujitsu.com/sg/products/devices/components	
<b>Europe</b> FUJITSU COMPONENTS EUROPE B.V. Diamantlaan 25 2132 WV Hoofddorp Netherlands Tel: (31-23) 5560910 Fax: (31-23) 5560950 Email: info@fceu.fujitsu.com Web: www.fujitsu.com/uk/components	<b>Hong Kong</b> FUJITSU COMPONENTS HONG KONG CO., LTD Unit 506, Inter-Continental Plaza No.94 Granville Road, Tsim Sha Tsui, Kowloon, Hong Kong Tel: (852) 2881-8495 Tex: (852) 2894-9512 Email: fcal@sg.fujitsu.com Web: www.fujitsu.com/sg/products/devices/components/	

©2018 Fujitsu Components Europe B.V. All rights reserved. All trademarks or registered trademarks are the property of their respective owners.

The contents, data and information in this datasheet are provided by Fujitsu Component Ltd. as a service only to its user and only for general information purposes.

The use of the contents, data and information provided in this datasheet is at the users' own risk.

Fujitsu has assembled this datasheet with care and will endeavor to keep the contents, data and information correct, accurate, comprehensive, complete and up to date.

Fujitsu Components Europe B.V. and affiliated companies do however not accept any responsibility or liability on their behalf, nor on behalf of its employees, for any loss or damage, direct, indirect or consequential, with respect to this datasheet, its contents, data, and information and related graphics and the correctness, reliability, accuracy, comprehensiveness, usefulness, availability and completeness thereof.

Nor do Fujitsu Components Europe B.V. and affiliated companies accept on their behalf, nor on behalf of its employees, any responsibility or liability for any representation or warrant of any kind, express or implied, including warranties of any kind for merchantability or fitness for particular use, with respect to these datasheets, its contents, data, information and related graphics and the correctness, reliability, accuracy, comprehensiveness, usefulness, availability and completeness thereof. Rev. March 16, 2018

# Mouser Electronics

Authorized Distributor

Click to View Pricing, Inventory, Delivery & Lifecycle Information:

[Fujitsu:](#)

[FTR-J2AK110W](#)



Компания «ЭлектроПласт» предлагает заключение долгосрочных отношений при поставках импортных электронных компонентов на взаимовыгодных условиях!

Наши преимущества:

- Оперативные поставки широкого спектра электронных компонентов отечественного и импортного производства напрямую от производителей и с крупнейших мировых складов;
- Поставка более 17-ти миллионов наименований электронных компонентов;
- Поставка сложных, дефицитных, либо снятых с производства позиций;
- Оперативные сроки поставки под заказ (от 5 рабочих дней);
- Экспресс доставка в любую точку России;
- Техническая поддержка проекта, помощь в подборе аналогов, поставка прототипов;
- Система менеджмента качества сертифицирована по Международному стандарту ISO 9001;
- Лицензия ФСБ на осуществление работ с использованием сведений, составляющих государственную тайну;
- Поставка специализированных компонентов (Xilinx, Altera, Analog Devices, Intersil, Interpoint, Microsemi, Aeroflex, Peregrine, Syfer, Eurofarad, Texas Instrument, Miteq, Cobham, E2V, MA-COM, Hittite, Mini-Circuits, General Dynamics и др.);

Помимо этого, одним из направлений компании «ЭлектроПласт» является направление «Источники питания». Мы предлагаем Вам помощь Конструкторского отдела:

- Подбор оптимального решения, техническое обоснование при выборе компонента;
- Подбор аналогов;
- Консультации по применению компонента;
- Поставка образцов и прототипов;
- Техническая поддержка проекта;
- Защита от снятия компонента с производства.



#### Как с нами связаться

**Телефон:** 8 (812) 309 58 32 (многоканальный)

**Факс:** 8 (812) 320-02-42

**Электронная почта:** [org@eplast1.ru](mailto:org@eplast1.ru)

**Адрес:** 198099, г. Санкт-Петербург, ул. Калинина, дом 2, корпус 4, литера А.