

# M series

## Miniature resistive joysticks

Distinctive features and specifications



- World's #1 selling joystick for CCTV applications
- Potentiometric sensing
- One, two or three axis
- Low profile design with 17 handle options
- RoHS

### MECHANICAL (FOR X AND Y AXIS)

- Break Out Force: 0.7N (0.16lbf)
- Operating Force: 1.3N (0.29lbf)
- Maximum Applied Force: 100N (22.48lbf)
- Mechanical Angle of Movement: 56°
- Expected Life: See potentiometer options
- Mass/weight: Varies
- Package Size (mm) (L x W x H) or (Dia x H): Varies
- Lever Action (Centering): Spring or Friction

### MECHANICAL (FOR Z AXIS)

- Break Out Torque: 0.022N·m (0.19lbf-in)
- Operating Torque: 0.040N·m (0.35lbf-in)
- Maximum Allowable Torque: 0.049N·m (0.43lbf-in)
- Mechanical Angle: 90°
- Handle Action: Spring

### ENVIRONMENTAL

- Operating Temperature: -25°C to 70°C (-13°F to 158°F)
- Storage Temperature: -40°C to 70°C (-40°F to 158°F)

### POTENTIOMETER OPTIONS

Potentiometer	P	M	R
Electrical Element	Conductive Plastic	Conductive Plastic	Conductive Plastic
Track Resistance	5K	5K	5K
Linearity	±1.0%	±5.0%	±1.0%
Track Operating Angle	220°	56°	50°
CRV	±1.5%	±1.5%	±1.0%
Power Dissipation	0.25W@40°C	0.5W@70°C	1W
Rotational Life	1,000,000	1,000,000	10,000,000

### CENTERING OPTIONS

- **SPRING CENTERING:** The joystick returns to center when the handle is released.
- **TORQUE SET:** Torque set provides absolute positioning with uniform friction applied to "X" and "Y" axis.

- NOTES:
- All values are nominal.
  - Specifications are subject to the joystick configuration.  
Contact Technical Support for the performance of your specific configuration.
  - The M Series is intended for internal applications.

Note: The company reserves the right to change specifications without notice.

# M series

## Miniature resistive joysticks

Overview

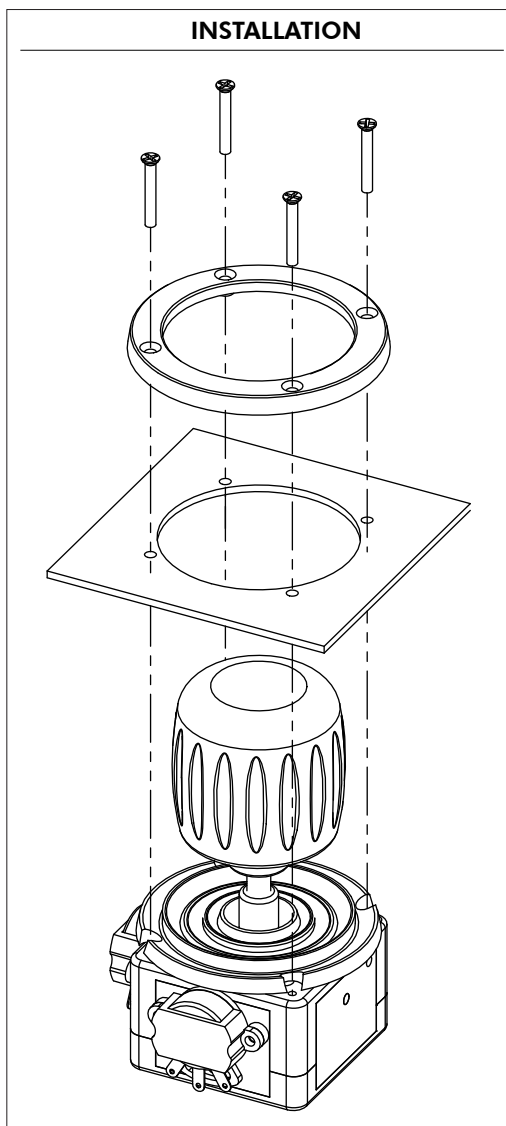
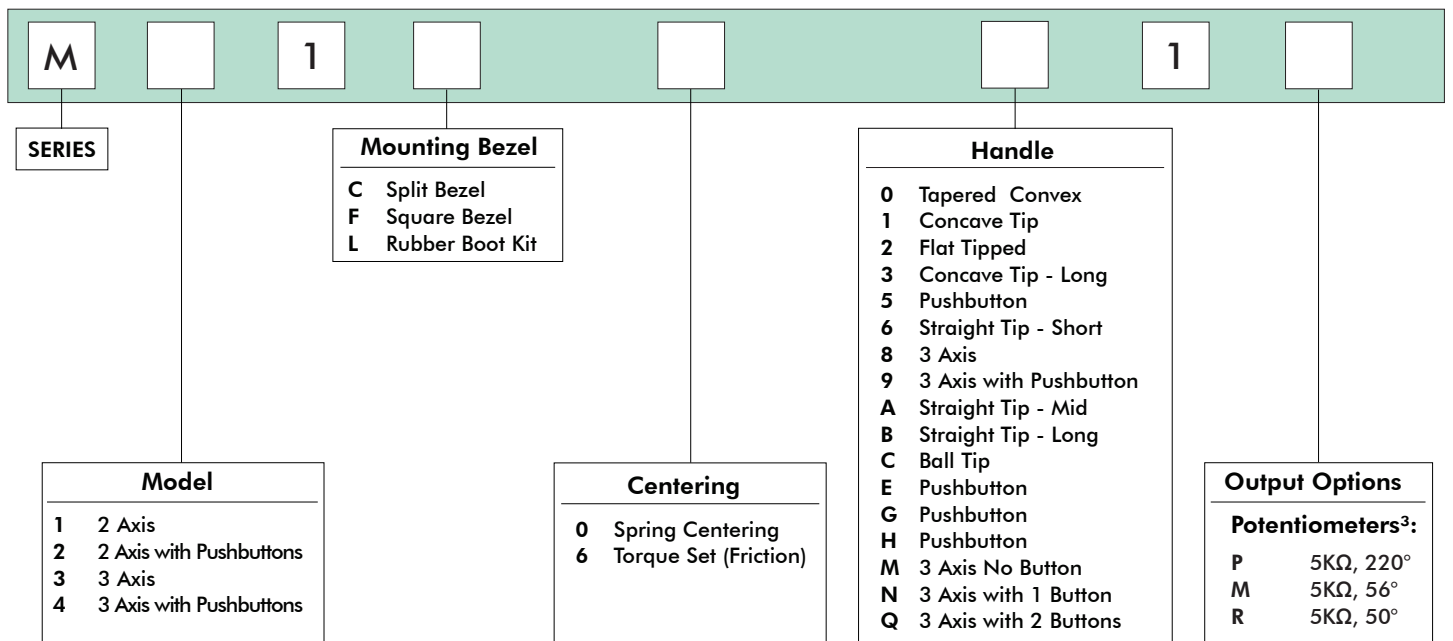

**NOTES:**

1. Front Mounting Bezels (FM)

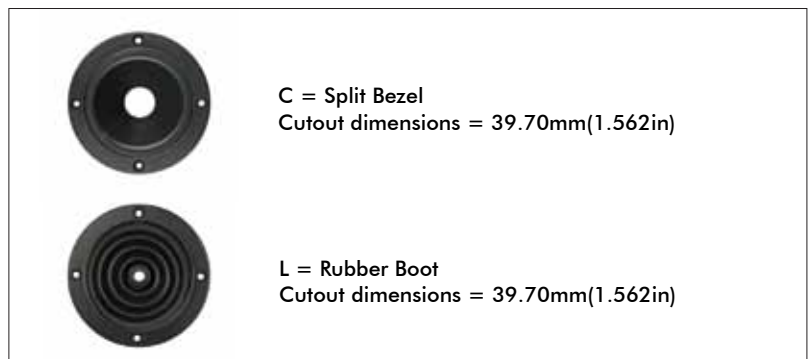

2. Rear mounting bezels (RM)

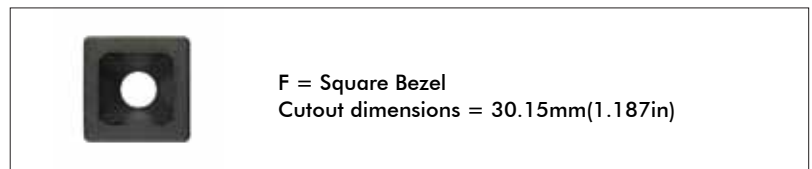

3. Potentiometer specifications are located on the previous page.



**Mounting accessories.**

Standard hardware includes:

C= Ring, cup, and 4 black Phl screws 2-56x1/2in

L= Ring and 4 black Phl screws 2-56x1/2in

F= Square bezel, 4 screws 2-56x1/2in Phl, and 4 screws 2-56x1/4in Phl

Note: The company reserves the right to change specifications without notice.

# M series

## Miniature resistive joysticks

Overview

### 2 AXIS WITH OPTION A HANDLE

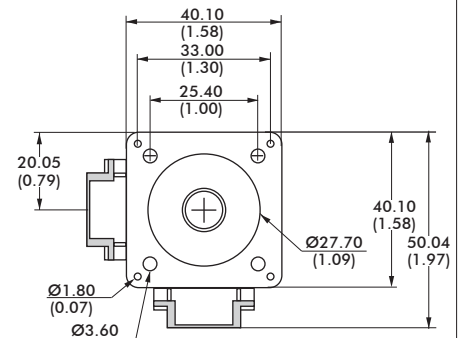
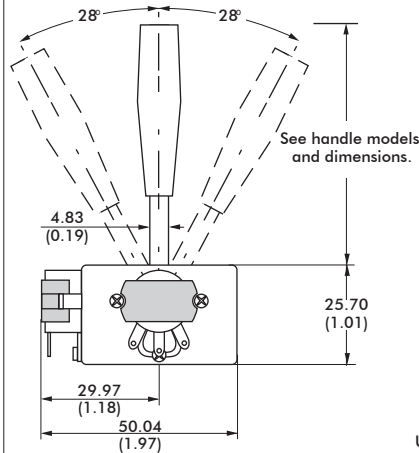

Used for Rear Mount "Square bezel"

**NOTES:**

1. Mechanical dimensions represent a joystick with the largest potentiometer option.
2. Potentiometer size will vary according to selected option.

### HANDLES

#### 2 AXIS

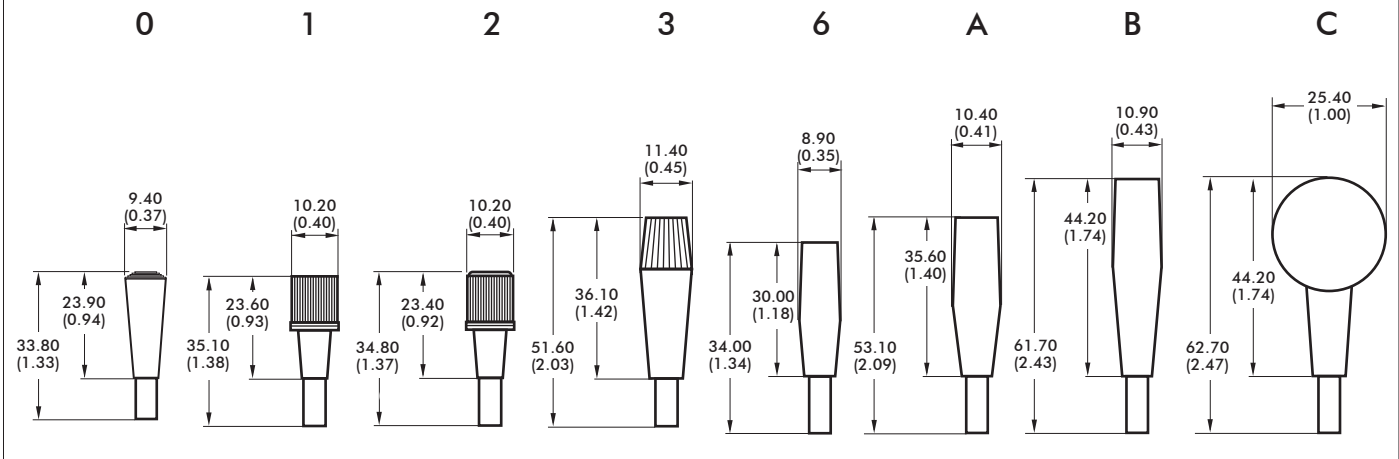

#### 2 AXIS WITH PUSHBUTTON<sup>1</sup>

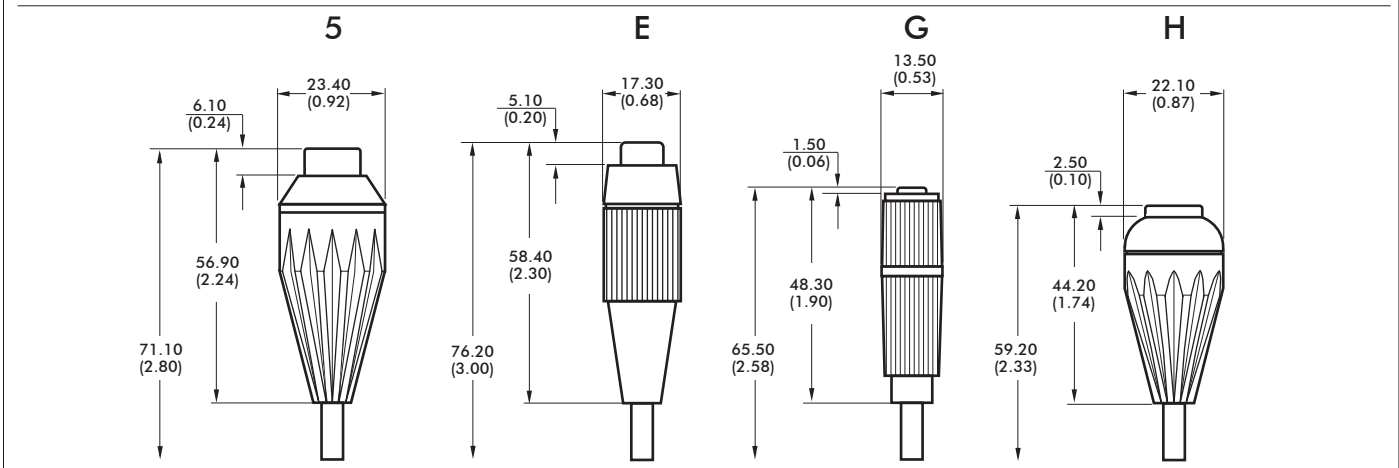

**NOTES:**

1. Pushbuttons are not sealed. Joysticks are intended for internal applications only.
2. Dimensions are in mm/(inch).

Note: The company reserves the right to change specifications without notice.

# M series

## Miniature resistive joysticks

### Overview

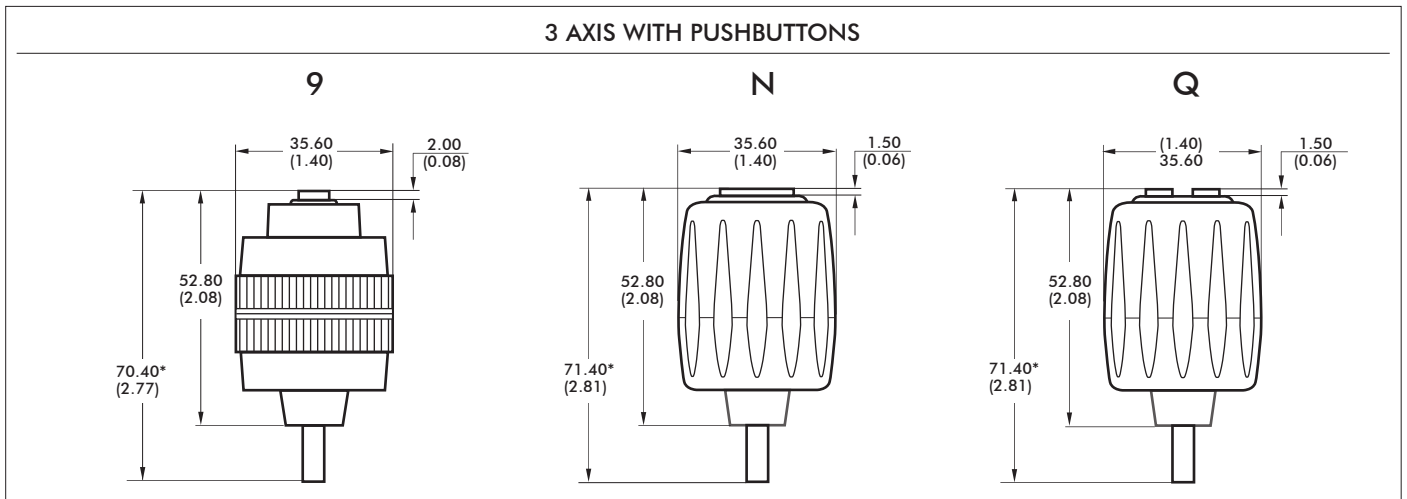
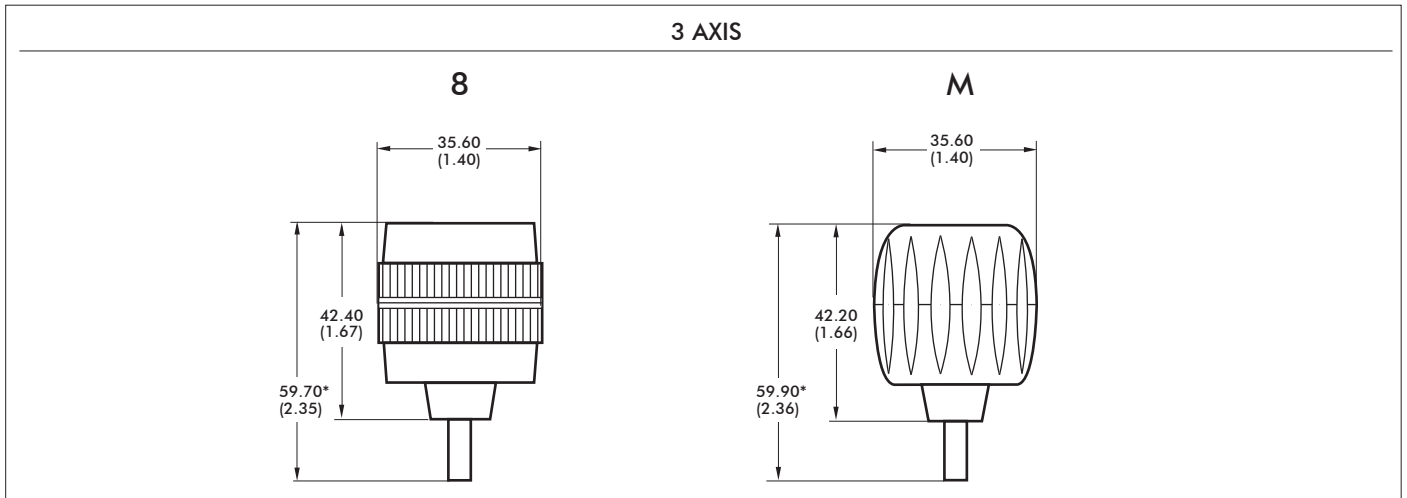

**NOTES:**

1. Dimensions are in mm/(inch).
2. Pushbuttons are not sealed. Joysticks are intended for internal applications only.
3. Axis orientation:
 

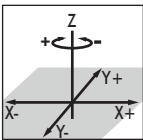
4. Wiring information:
  - Cables are provided for pushbuttons and the Z axis.
  - Cables are not supplied for the potentiometers (axis X and Y).

DEFAULT WIRE COLOR CODE*		
COLOR	FUNCTION	AWG
<b>2 OR 3 AXIS JOYSTICK WITH 1 PUSHBUTTON - OPTIONS 5,E,G,H,9,N</b>		
ORANGE	Switch 1	28
ORANGE	Switch Common	
<b>3 AXIS JOYSTICK WITH 2 PUSHBUTTONS - Option Q**</b>		
ORANGE	Switch 1	28
BROWN	Switch 2	
GREEN	Switch Common	
<b>Z AXIS IN A 3 AXIS JOYSTICK - OPTIONS 8,9,M,N,Q</b>		
RED	Supply	28
WHITE	Signal	
BLUE	Return	

**NOTES:** \* Wires for the Z axis and for the pushbuttons are 292mm (11.5in) and stripped.

\*\* Handle "Q" pushbuttons are shown in the following drawing:

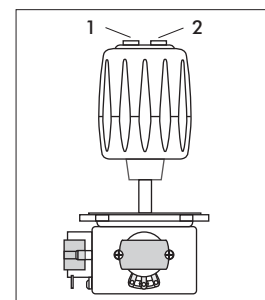

Note: The company reserves the right to change specifications without notice.



Компания «ЭлектроПласт» предлагает заключение долгосрочных отношений при поставках импортных электронных компонентов на взаимовыгодных условиях!

Наши преимущества:

- Оперативные поставки широкого спектра электронных компонентов отечественного и импортного производства напрямую от производителей и с крупнейших мировых складов;
- Поставка более 17-ти миллионов наименований электронных компонентов;
- Поставка сложных, дефицитных, либо снятых с производства позиций;
- Оперативные сроки поставки под заказ (от 5 рабочих дней);
- Экспресс доставка в любую точку России;
- Техническая поддержка проекта, помощь в подборе аналогов, поставка прототипов;
- Система менеджмента качества сертифицирована по Международному стандарту ISO 9001;
- Лицензия ФСБ на осуществление работ с использованием сведений, составляющих государственную тайну;
- Поставка специализированных компонентов (Xilinx, Altera, Analog Devices, Intersil, Interpoint, Microsemi, Aeroflex, Peregrine, Syfer, Eurofarad, Texas Instrument, Miteq, Cobham, E2V, MA-COM, Hittite, Mini-Circuits, General Dynamics и др.);

Помимо этого, одним из направлений компании «ЭлектроПласт» является направление «Источники питания». Мы предлагаем Вам помощь Конструкторского отдела:

- Подбор оптимального решения, техническое обоснование при выборе компонента;
- Подбор аналогов;
- Консультации по применению компонента;
- Поставка образцов и прототипов;
- Техническая поддержка проекта;
- Защита от снятия компонента с производства.



#### Как с нами связаться

**Телефон:** 8 (812) 309 58 32 (многоканальный)

**Факс:** 8 (812) 320-02-42

**Электронная почта:** [org@eplast1.ru](mailto:org@eplast1.ru)

**Адрес:** 198099, г. Санкт-Петербург, ул. Калинина, дом 2, корпус 4, литера А.