

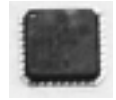

**3.3V, 2.0GHz ANY DIFF. IN-TO-LVDS  
PROGRAMMABLE CLOCK DIVIDER  
FANOUT BUFFER W/ INTERNAL TERMINATION**

**Precision Edge®  
SY89873L**



Precision Edge®

## FEATURES

- **Guaranteed AC performance**
  - > 2.0GHz  $f_{MAX}$  output toggle
  - > 3.0GHz  $f_{MAX}$  input
  - < 800ps  $t_{PD}$  (matched-delay between banks)
  - < 15ps within-device skew
  - < 190ps rise/fall time
- **Low jitter design**
  - < 1ps<sub>RMS</sub> cycle-to-cycle jitter
  - < 10ps<sub>pp</sub> total jitter
- **Unique input termination and  $V_T$  pin for DC-coupled and AC-coupled inputs: any differential inputs (LVPECL, LVDS, CML, HSTL)**
- **Precision differential LVDS outputs**
- **Matched delay: all outputs have matched delay, independent of divider setting**
- **TTL/CMOS inputs for select and reset/disable**
- **Two LVDS output banks (matched delay)**
  - **Bank A: Buffered copy of input clock (undivided)**
  - **Bank B: Divided output ( $\div 2, \div 4, \div 8, \div 16$ ), two copies**
- **3.3V power supply**
- **Wide operating temperature range:  $-40^{\circ}\text{C}$  to  $+85^{\circ}\text{C}$**
- **Available in 16-pin (3mm x 3mm) MLF® package**

## APPLICATIONS

- **SONET/SDH line cards**
- **Transponders**
- **High-end, multiprocessor servers**

## FUNCTIONAL BLOCK DIAGRAM

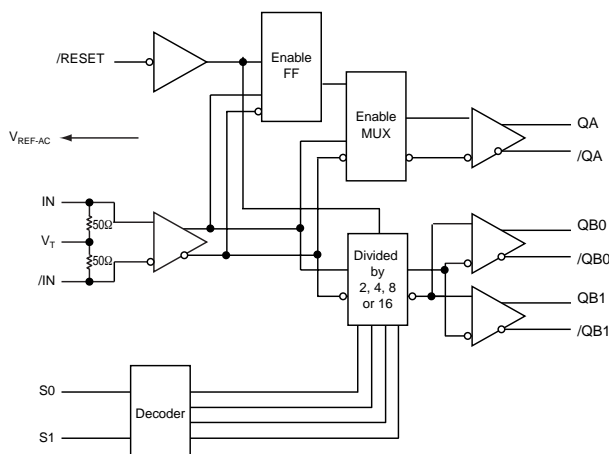

## DESCRIPTION

This 3.3V low-skew, low-jitter, precision LVDS output clock divider accepts any high-speed differential clock input (AC- or DC-coupled) CML, LVPECL, HSTL or LVDS and divides down the frequency using a programmable divider ratio to create a frequency-locked, lower speed version of the input clock. The SY89873L includes two output banks. Bank A is an exact copy of the input clock (pass through) with matched propagation delay to Bank B, the divided output bank. Available divider ratios are 2, 4, 8 and 16. In a typical 622MHz clock system this would provide availability of 311MHz, 155MHz, 77MHz or 38MHz auxiliary clock components.

The differential input buffer has a unique internal termination design that allows access to the termination network through a  $V_T$  pin. This feature allows the device to easily interface to all AC- or DC-coupled differential logic standards. A  $V_{REF-AC}$  reference is included for AC-coupled applications.

The SY89873L is part of Micrel's high-speed Precision Edge® timing and distribution family. For 2.5V applications, consider the SY89872U. For applications that require an LVPECL output, consider the SY89871U.

The /RESET input asynchronously resets the divider outputs (Bank B). In the pass-through function (Bank A) the /RESET synchronously enables or disables the outputs on the next falling edge of IN (rising edge of /N). Refer to the Timing Diagram.

All support documentation can be found on Micrel's web site at: [www.micrel.com](http://www.micrel.com).

## TYPICAL APPLICATION

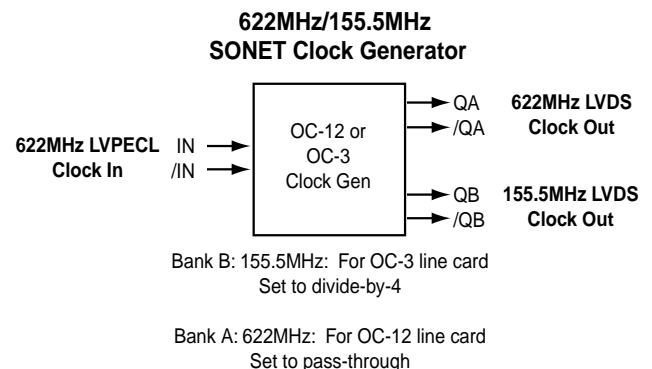

Precision Edge is a registered trademark of Micrel, Inc.  
MicroLeadFrame and MLF are registered trademarks of Amkor Technology, Inc.

**PACKAGE/ORDERING INFORMATION**

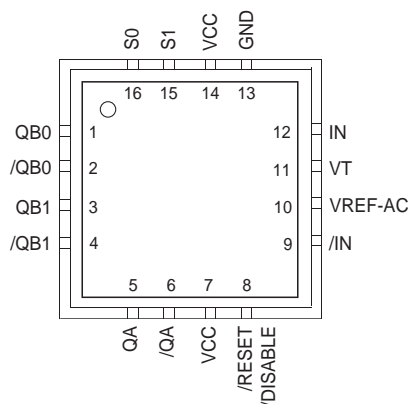

**16-Pin MLF® (MLF-16)**

**Ordering Information<sup>(1)</sup>**

Part Number	Package Type	Operating Range	Package Marking	Lead Finish
SY89873LMI	MLF-16	Industrial	873L	Sn-Pb
SY89873LMITR <sup>(2)</sup>	MLF-16	Industrial	873L	Sb-Pb
SY89873LMG <sup>(3)</sup>	MLF-16	Industrial	873L with Pb-Free bar line indicator	NiPdAu Pb-Free
SY89873LMGTR <sup>(2, 3)</sup>	MLF-16	Industrial	873L with Pb-Free bar line indicator	NiPdAu Pb-Free

**Notes:**

1. Contact factory for die availability. Dice are guaranteed at T<sub>A</sub> = 25°C, DC Electricals only.
2. Tape and Reel.
3. Pb-Free package is recommended for new designs.

**PIN DESCRIPTION**

Pin Number	Pin Name	Pin Function
1, 2, 3, 4	QB0, /QB0 QB1, /QB1	Differential Buffered Output Clocks: Divide by 2, 4, 8, 16. LVDS compatible.
5, 6	QA, /QA	Differential Buffered Undivided Output Clock: LVDS compatible.
7, 14	VCC	Positive Power Supply: Bypass with 0.1μF//0.01μF low ESR capacitors.
8	/RESET, /DISABLE	TTL/CMOS Compatible Output Reset and Disable: Internal 25kΩ pull-up. Input threshold is V <sub>CC</sub> /2. Logic LOW will reset the divider select, and align Bank A and Bank B edges. In addition, when LOW, Banks A and B will be disabled.
12, 9	IN, /IN	Differential Input: Internal 50Ω termination resistors to V <sub>T</sub> input. See "Input Interface Applications" section.
10	VREF-AC	Reference Voltage: Equal to V <sub>CC</sub> -1.4V (approx.), and used for AC-coupled applications. Maximum sink/source current is 0.5mA. See "Input Interface Applications" section.
11	VT	Termination Center-Tap: For CML and LVDS inputs, leave this pin floating. Otherwise, see "Input Interface Applications" section.
13	GND	Ground: Exposed pad is internally connected to GND and must be connected to a ground plane for proper thermal operation.
16, 15	S0, S1	Select Pins: LVTTL/CMOS logic levels. Internal 25kΩ pull-up resistor. Logic HIGH if left unconnected (divided by 16 mode). S0 = LSB. Input threshold is V <sub>CC</sub> /2.

**TRUTH TABLE**

/RESET /DISABLE	S1	S0	Bank A Output	Bank B Outputs
1	0	0	Input Clock	Input Clock ÷ 2
1	0	1	Input Clock	Input Clock ÷ 4
1	1	0	Input Clock	Input Clock ÷ 8
1	1	1	Input Clock	Input Clock ÷ 16
0	X	X	QA = LOW, /QA = HIGH <sup>(1)</sup>	QB0 = LOW, /QB0 = HIGH <sup>(2)</sup> QB1 = LOW, /QB1 = HIGH <sup>(2)</sup>

**Notes:**

1. On the next negative transition of the input signal.
2. Asynchronous Reset/Disable function. See "Timing Diagram."

### Absolute Maximum Ratings<sup>(1)</sup>

Supply Voltage ( $V_{CC}$ )	-0.5V to +4.0V
Input Voltage ( $V_{IN}$ )	-0.5V to $V_{CC}+0.3$
LVDS Output Current ( $I_{OUT}$ )	$\pm 10$ mA
Input Current $I_N$ , /IN ( $I_{IN}$ )	$\pm 50$ mA
$V_{REF-AC}$ Input Sink/Source Current ( $I_{VREF-AC}$ ) <sup>(3)</sup>	$\pm 2$ mA
Lead Temperature (soldering, 20 sec.)	260°C
Storage Temperature ( $T_S$ )	-65°C to +150°C

### Operating Ratings<sup>(2)</sup>

Supply Voltage ( $V_{CC}$ )	+3.3V $\pm 10\%$
Ambient Temperature ( $T_A$ )	-40°C to +85°C
Package Thermal Resistance	
MLF® ( $\theta_{JA}$ )	
Still-Air	60°C/W
500 lfpm	54°C/W
MLF® ( $\Psi_{JB}$ ) <sup>(4)</sup>	
Junction-to-Board	38°C/W

## DC ELECTRICAL CHARACTERISTICS<sup>(5)</sup>

$T_A = -40^\circ\text{C}$  to  $+85^\circ\text{C}$ ; Unless otherwise stated.

Symbol	Parameter	Condition	Min	Typ	Max	Units
$V_{CC}$	Power Supply		3.0	3.3	3.6	V
$I_{CC}$	Power Supply Current	No load, Max $V_{CC}$		85	115	mA
$R_{IN}$	Differential Input Resistance (IN-to-/IN)		90	100	110	$\Omega$
$V_{IH}$	Input High Voltage IN, /IN	Note 6	0.1		$V_{CC}+0.3$	V
$V_{IL}$	Input Low Voltage IN, /IN	Note 6	-0.3		$V_{CC}$	V
$V_{IN}$	Input Voltage Swing	Notes 6, 7	0.1		3.6	V
$V_{DIFF\_IN}$	Differential Input Voltage Swing	Notes 6, 7, 8	0.2			V
$ I_{IN} $	Input Current IN, /IN	Note 6			45	mA
$V_{REF-AC}$	Reference Voltage	Note 9	$V_{CC}-1.525$	$V_{CC}-1.425$	$V_{CC}-1.325$	V

**Notes:**

1. Permanent device damage may occur if "Absolute Maximum Ratings" are exceeded. This is a stress rating only and functional operation is not implied at conditions other than those detailed in the operational sections of this data sheet. Exposure to "Absolute Maximum Ratings" conditions for extended periods may affect device reliability.
2. The data sheet limits are not guaranteed if the device is operated beyond the operating ratings.
3. Due to the limited drive capability use for input of the same package only.
4. Junction-to-board resistance assumes exposed pad is soldered (or equivalent) to the device's most negative potential on the PCB.
5. The circuit is designed to meet the DC specifications shown in the above table after thermal equilibrium has been established.
6. Due to the internal termination (see "Input Buffer Structure") the input current depends on the applied voltages at IN, /IN and  $V_T$  inputs. Do not apply a combination of voltages that causes the input current to exceed the maximum limit!
7. See "Timing Diagram" for  $V_{IN}$  definition.  $V_{IN(max)}$  is specified when  $V_T$  is floating.
8. See Figures 1c and 1d for  $V_{DIFF}$  definition.
9. Operating using  $V_{IN}$  is limited to AC-coupled PECL or CML applications only. Connect directly to  $V_T$  pin.

**LVDS OUTPUT DC ELECTRICAL CHARACTERISTICS<sup>(10)</sup>**

$V_{CC} = 3.3V \pm 10\%$ ;  $T_A = -40^\circ\text{C}$  to  $+85^\circ\text{C}$ ; Unless otherwise stated.

Symbol	Parameter	Condition	Min	Typ	Max	Units
$V_{OUT}$	Output Voltage Swing	Notes 11, 12	250	350	450	mV
$V_{OH}$	Output High Voltage	Note 11			1.475	V
$V_{OL}$	Output Low Voltage	Note 11	0.925			V
$V_{OCM}$	Output Common Mode Voltage	Note 11	1.125		1.275	V
$\Delta V_{OCM}$	Change in Common Mode Voltage		-50		50	mV

**LVTTTL/CMOS DC ELECTRICAL CHARACTERISTICS<sup>(10)</sup>**

$V_{CC} = 3.3V \pm 10\%$ ;  $T_A = -40^\circ\text{C}$  to  $+85^\circ\text{C}$ ; Unless otherwise stated.

Symbol	Parameter	Condition	Min	Typ	Max	Units
$V_{IH}$	Input HIGH Voltage		2.0			V
$V_{IL}$	Input LOW Voltage				0.8	V
$I_{IH}$	Input HIGH Current		-125		20	$\mu\text{A}$
$I_{IL}$	Input LOW Current				-300	$\mu\text{A}$

**Notes:**

10. The circuit is designed to meet the DC specifications shown in the above table after thermal equilibrium has been established.

11. Measured as per Figure 1a,  $100\Omega$  across Q and /Q outputs.

12. See Figure 1c.

**AC ELECTRICAL CHARACTERISTICS<sup>(13)</sup>**

V<sub>CC</sub> = 3.3V ±10%; T<sub>A</sub> = -40°C to +85°C; Unless otherwise stated.

Symbol	Parameter	Condition	Min	Typ	Max	Units
f <sub>MAX</sub>	Maximum Output Toggle Frequency (Bank A and Bank B)	Output Swing: ≥ 200mV	2.0			GHz
	Maximum Input Frequency	Note 14	3.2			GHz
t <sub>PD</sub>	Differential Propagation Delay (IN-to-Q)	Input Swing < 400mV	550	660	800	ps
		Input Swing ≥ 400mV	500	610	750	ps
t <sub>SKEW</sub>	Within-Device Skew (diff.) (QB0-to-QB1)	Note 15		7	15	ps
	Within-Device Skew (diff.) (Bank A-to-Bank B)	Note 15		12	30	ps
	Part-to-Part Skew (diff.)	Note 15			250	ps
t <sub>rr</sub>	Reset Recovery Time	Note 16	600			ps
T <sub>jitter</sub>	Cycle-to-Cycle Jitter	Note 17			1	ps <sub>RMS</sub>
	Total Jitter	Note 18			10	ps <sub>pp</sub>
t <sub>r</sub> , t <sub>f</sub>	Rise / Fall Time (20% to 80%)		60	110	190	ps

**Notes:**

- 13. Measured with 400mV input signal, 50% duty cycle. All outputs terminated with 100Ω between Q and /Q, unless otherwise stated.
- 14. Bank A (pass-through) maximum frequency is limited by the output stage. Bank B (input-to-output +2, +4, +8, +16) can accept an input frequency >3GHz, while Bank A will be slew-rate limited.
- 15. Skew is measured between outputs under identical transitions.
- 16. See "Timing Diagram."
- 17. Cycle-to-cycle jitter definition: the variation in period between adjacent cycles over a random sample of adjacent cycle pairs.  $T_{jitter\_cc} = T_n - T_{n+1}$ , where T is the time between rising edges of the output signal.
- 18. Total jitter definition: with an ideal clock input, of frequency ≤ f<sub>MAX</sub> (device), no more than one output edge in 10<sup>12</sup> output edges will deviate by more than the specified peak-to-peak jitter value.

**LVDS OUTPUT**

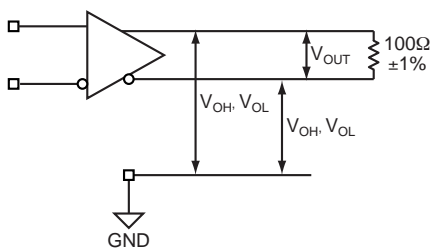

Figure 1a. LVDS Differential Measurement

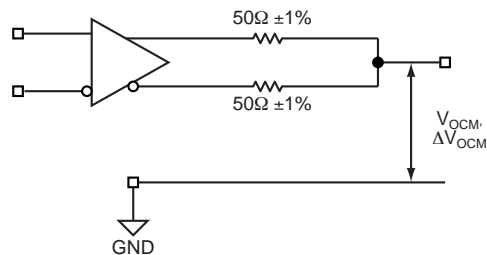

Figure 1b. LVDS Common Mode Measurement

**DEFINITION OF SINGLE-ENDED AND DIFFERENTIAL SWING**

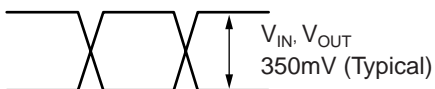

Figure 1c. Single-Ended Swing

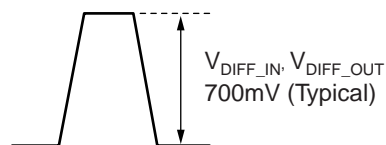
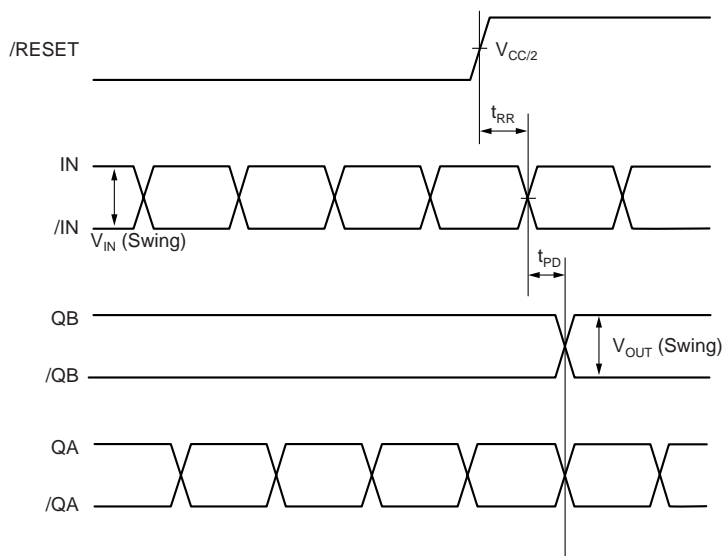

Figure 1d. Differential Swing

**TIMING DIAGRAM**



**TYPICAL OPERATING CHARACTERISTICS**

$V_{CC} = 3.3V$ ,  $V_{IN} = 400mV$ ,  $T_A = 25^{\circ}C$ , unless otherwise stated.

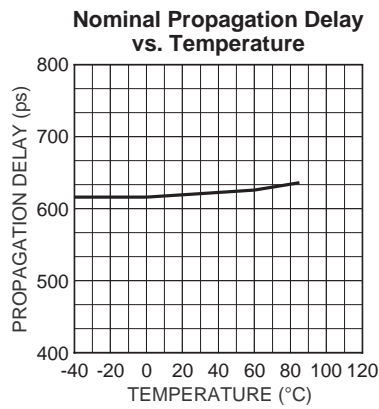
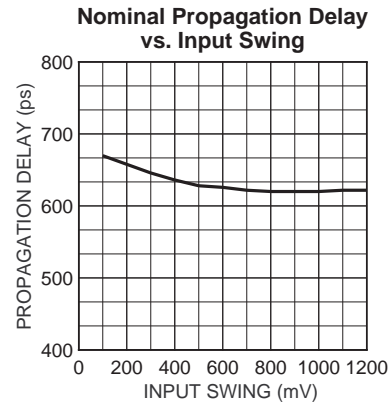
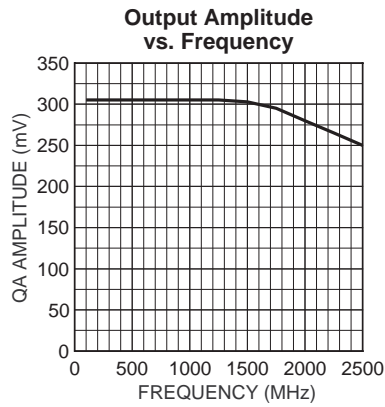

# FUNCTIONAL CHARACTERISTICS

Conditions:  $V_{CC} = 3.3V$ ,  $T_A = 25^{\circ}C$ , unless otherwise stated.

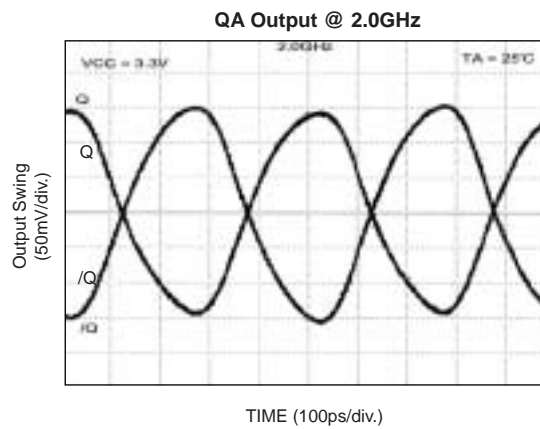
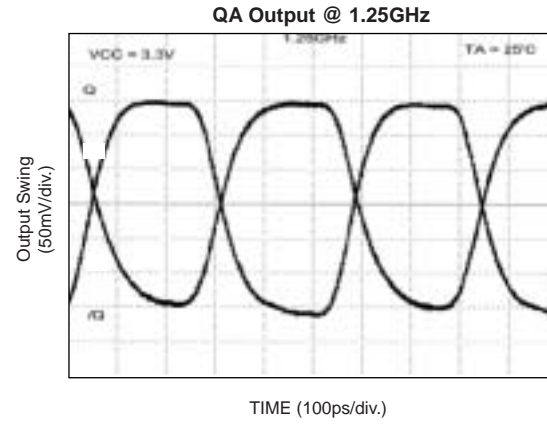
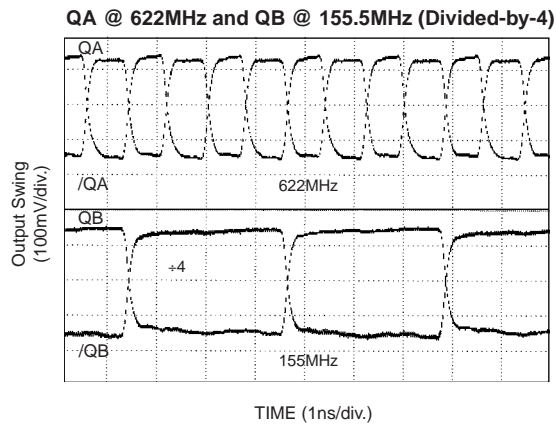



**INPUT BUFFER STRUCTURE**

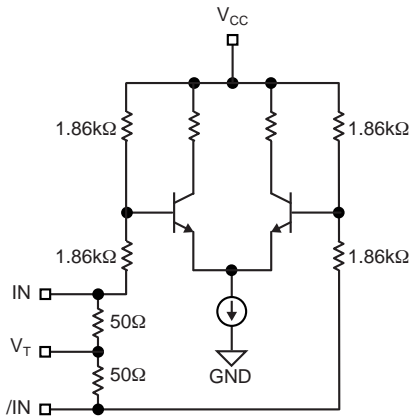

Figure 2a. Simplified Differential Input Stage

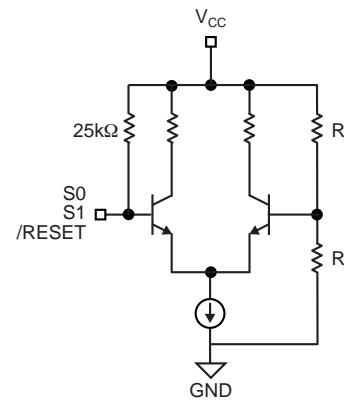
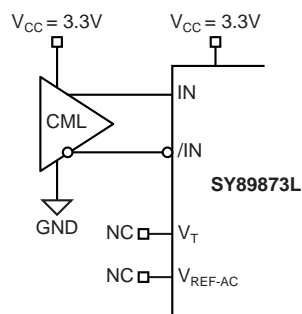
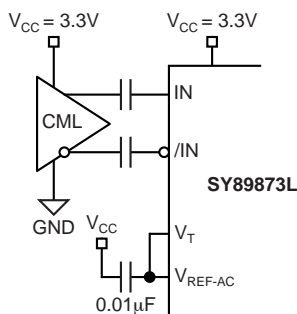

Figure 2b. Simplified TTL/CMOS Input

**INPUT INTERFACE APPLICATIONS**



**Figure 3a. DC-Coupled CML Input Interface**



**Figure 3b. AC-Coupled CML Input Interface**

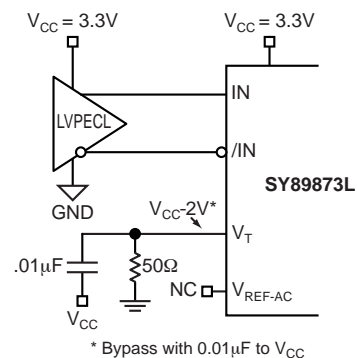

**Figure 3c. DC-Coupled LVPECL Input Interface**

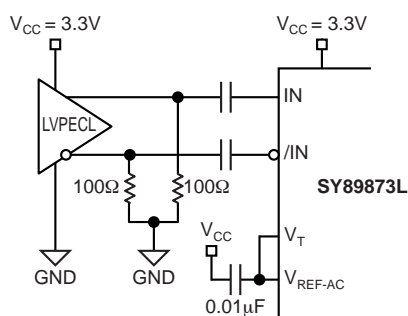

**Figure 3d. AC-Coupled LVPECL Input Interface**

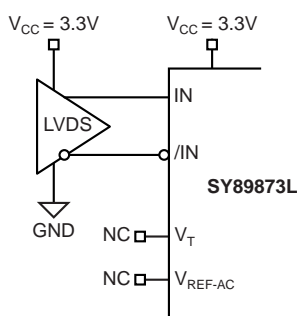

**Figure 3e. LVDS Input Interface**

**Figure 3f. HSTL Input Interface**

**RELATED MICREL PRODUCTS AND SUPPORT DOCUMENTATION**

Part Number	Function	Data Sheet Link
SY89871U	2.5GHz Any Diff. In-to-LVPECL Programmable Clock Divider/Fanout Buffer w/Internal Termination	<a href="http://www.micrel.com/product-info/products/sy89871u.shtml">www.micrel.com/product-info/products/sy89871u.shtml</a>
SY89872U	2.5V 2GHz Any Diff. In-to-LVDS Programmable Clock Divider/Fanout Buffer w/Internal Termination	<a href="http://www.micrel.com/product-info/products/sy89872u.shtml">www.micrel.com/product-info/products/sy89872u.shtml</a>
	MLF® Application Note	<a href="http://www.amkor.com/products/notes_papers/MLF_AppNote_0902.pdf">www.amkor.com/products/notes_papers/MLF_AppNote_0902.pdf</a>
HBW Solutions	New Products and Applications	<a href="http://www.micrel.com/product-info/products/solutions.shtml">www.micrel.com/product-info/products/solutions.shtml</a>

**16-PIN MicroLeadFrame® (MLF-16)**

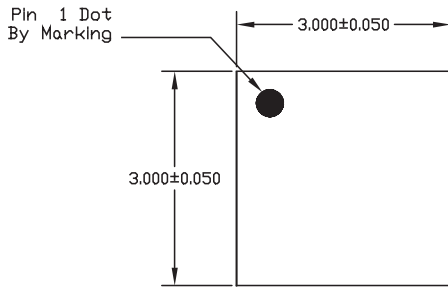

TOP VIEW

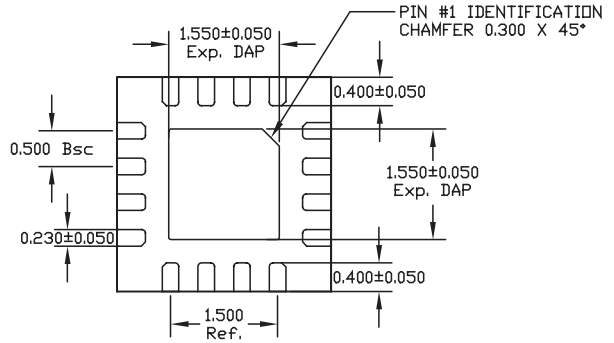

BOTTOM VIEW

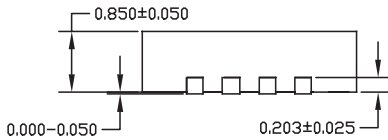

SIDE VIEW

- NOTE:
1. ALL DIMENSIONS ARE IN MILLIMETERS.
  2. MAX. PACKAGE WARPAGE IS 0.05 mm.
  3. MAXIMUM ALLOWABLE BURRS IS 0.076 mm IN ALL DIRECTIONS.
  4. PIN #1 ID ON TOP WILL BE LASER/INK MARKED.

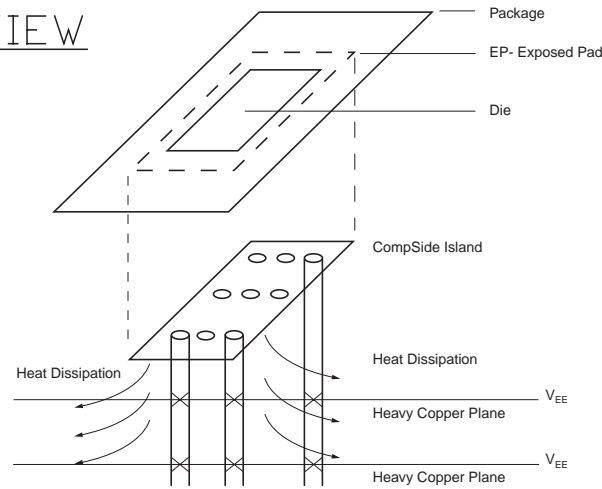

**PCB Thermal Consideration for 16-Pin MLF® Package  
(Always solder, or equivalent, the exposed pad to the PCB)**

**Package Notes:**

1. Package meets Level 2 moisture sensitivity classification, and is shipped in dry-pack form.
2. Exposed pads must be soldered to a ground for proper thermal management.

**MICREL, INC. 2180 FORTUNE DRIVE SAN JOSE, CA 95131 USA**

TEL + 1 (408) 944-0800 FAX + 1 (408) 474-1000 WEB <http://www.micrel.com>

The information furnished by Micrel in this data sheet is believed to be accurate and reliable. However, no responsibility is assumed by Micrel for its use. Micrel reserves the right to change circuitry and specifications at any time without notification to the customer.

Micrel Products are not designed or authorized for use as components in life support appliances, devices or systems where malfunction of a product can reasonably be expected to result in personal injury. Life support devices or systems are devices or systems that (a) are intended for surgical implant into the body or (b) support or sustain life, and whose failure to perform can be reasonably expected to result in a significant injury to the user. A Purchaser's use or sale of Micrel Products for use in life support appliances, devices or systems is at Purchaser's own risk and Purchaser agrees to fully indemnify Micrel for any damages resulting from such use or sale.

© 2006 Micrel, Incorporated.



Компания «ЭлектроПласт» предлагает заключение долгосрочных отношений при поставках импортных электронных компонентов на взаимовыгодных условиях!

Наши преимущества:

- Оперативные поставки широкого спектра электронных компонентов отечественного и импортного производства напрямую от производителей и с крупнейших мировых складов;
- Поставка более 17-ти миллионов наименований электронных компонентов;
- Поставка сложных, дефицитных, либо снятых с производства позиций;
- Оперативные сроки поставки под заказ (от 5 рабочих дней);
- Экспресс доставка в любую точку России;
- Техническая поддержка проекта, помощь в подборе аналогов, поставка прототипов;
- Система менеджмента качества сертифицирована по Международному стандарту ISO 9001;
- Лицензия ФСБ на осуществление работ с использованием сведений, составляющих государственную тайну;
- Поставка специализированных компонентов (Xilinx, Altera, Analog Devices, Intersil, Interpoint, Microsemi, Aeroflex, Peregrine, Syfer, Eurofarad, Texas Instrument, Miteq, Cobham, E2V, MA-COM, Hittite, Mini-Circuits, General Dynamics и др.);

Помимо этого, одним из направлений компании «ЭлектроПласт» является направление «Источники питания». Мы предлагаем Вам помощь Конструкторского отдела:

- Подбор оптимального решения, техническое обоснование при выборе компонента;
- Подбор аналогов;
- Консультации по применению компонента;
- Поставка образцов и прототипов;
- Техническая поддержка проекта;
- Защита от снятия компонента с производства.



#### Как с нами связаться

**Телефон:** 8 (812) 309 58 32 (многоканальный)

**Факс:** 8 (812) 320-02-42

**Электронная почта:** [org@eplast1.ru](mailto:org@eplast1.ru)

**Адрес:** 198099, г. Санкт-Петербург, ул. Калинина, дом 2, корпус 4, литера А.