

**Bayonet Coupling, Crimp Contacts
Circular Connectors**

GT / D Series

JAE

JAE Japan Aviation Electronics
Industry, Limited

Circular Connectors

GT/D Series

- HIGH PERFORMANCE & RELIABILITY
- BAYONET COUPLING & LOCKING
- CRIMP SNAP-IN CONTACTS

JAE's subminiature GT/D series circular connectors are rugged, crimp type connectors which are most appropriately used in transportation, broadcasting equipment, and for other industrial applications.

The coupling is bayonet locking type and the mating and unmating is accomplished simply and securely by slight rotation of the coupling nut.

GT/D contact is crimp snap-in type and the termination is accomplished with easy-handling crimping tool which provides uniform speedy crimp termination.

With an extraction tool, the contact can be extracted from the rear of the insulator.

The four contact sizes (#16 is standard) are available, depending on the applicable wires and are distinguished with bin code.

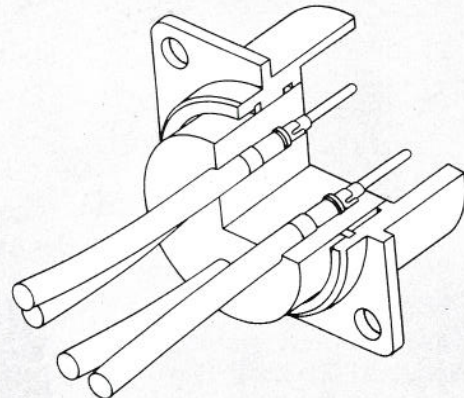
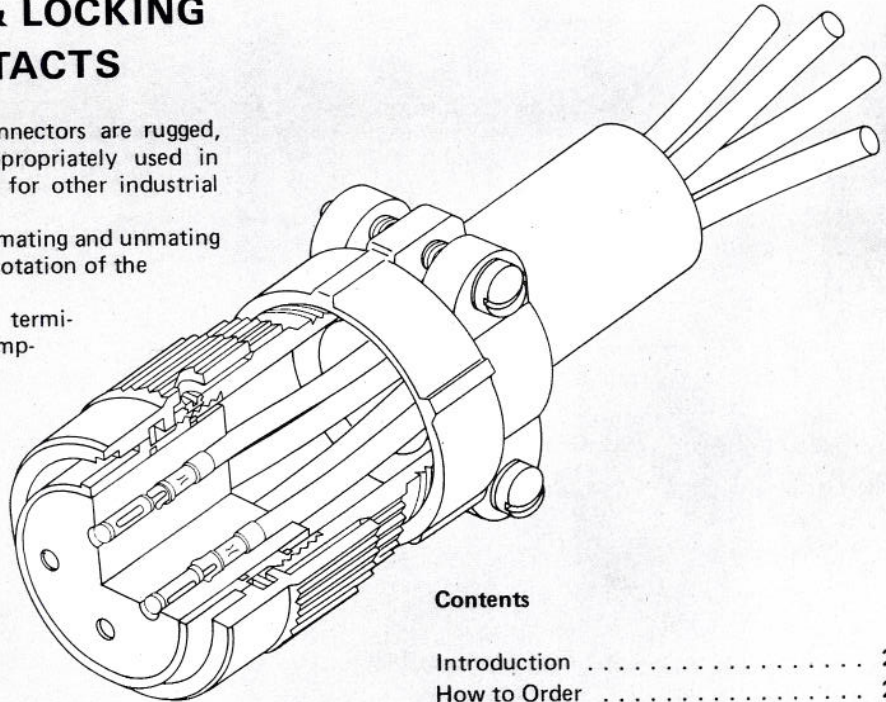

Contents

Introduction	2
How to Order	2
Contact Arrangements	3
Standard Data	3
Materials & Finishes	3
Receptacle	4
Plug	4-5
Dust Cap	5
Crimp type contacts	4-5
Crimping & Contact	
Insertion/Extraction tools	6-7

HOW TO ORDER

GT/D6A-22-M31SCX-A-(20)-FO

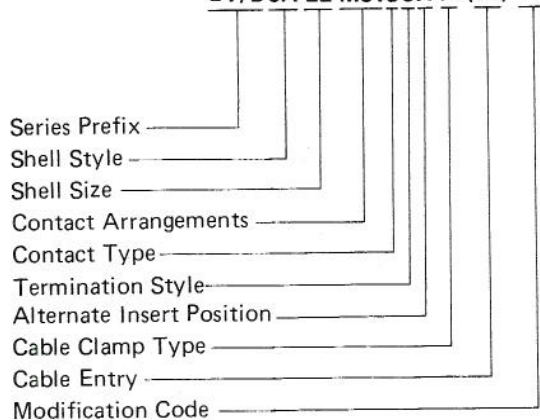

Shell Style: 2A-box mounting receptacle
6A-straight plug
8B-90° angle plug

Shell Size: 12, 16, 18, 22, 24 and 28

Contact Arrangements: see following page

Termination Style: C ... C rimp

Contact Type: P-pin S-socket

Alternate Insert Position: W, X and Y (omit normal)

Cable Clamp Type: A-MS3057A style

Cable Entry: bushing inner diameter

Modification Code: FO — Connector supplied without contacts. Contacts to be ordered separately (The code FO will not be stamped on connector)

Contact Arrangements

Contact Arrangements
(Face view of pin insert)

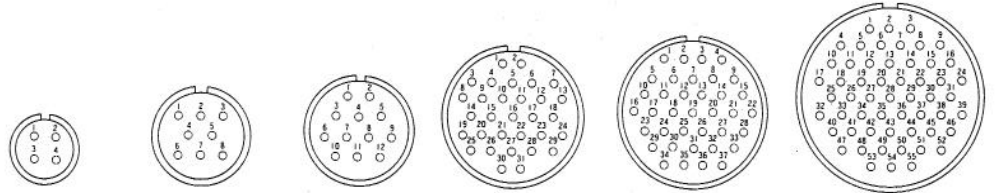

Contact Arrangements	12-M4	16-M8	18-M12	22-M31	24-M37	28-M55
Number of Contacts	4	8	12	31	37	55
D.W.V. VAC (RMS)	2000V	2000V	2000V	2000V	2000V	2000V

Alternate Insert Position

The diagram and the tabulation at the right indicate alternate insert position. The three positions (W, X and Y) differ in degree of rotation for various sizes and arrangements. With these alternate insert positions, the connectors of same size and the same contact arrangements can be used side by side without mis-mating.

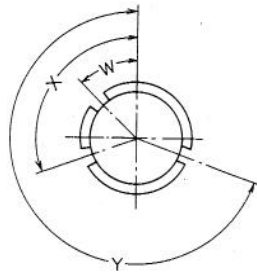

(Face view of pin insert)

No. of Contacts	Contact Arrangement	ROTATION		
		W°	X°	Y°
4	12-M4	—	60	120
8	16-M8	45	110	250
12	18-M12	90	180	270
31	22-M31	80	110	250
37	24-M37	80	110	250
55	28-M55	80	110	250

Standard Data

Current Rating:	13amp
Dielectric Withstanding	
Voltage:	2000VAC (r.m.s.) one minute
Insulation Resistance:	5000 megohms min.
Individual Contact	Mating force . . . 450g min.
Mating/Unmating Force:	Unmating force . . . 60g min.
Contact Retention Force:	4.5kgs. min.
Temperature Range:	-55°C ~ +85°C
Durability:	500 cycles mating/unmating
Contact Termination:	Crimp snap-in
Polarization:	5 key and keyways
Coupling:	3 point bayonet

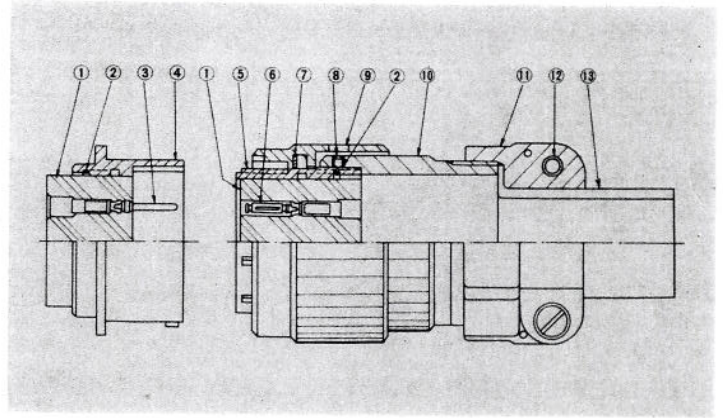

	Description	Materials	Finishes
1	Insulator	Plastic	UL-94V-0
2	Retaining Ring	Copper Alloy	Nickel Plate
3	Pin Contact	Copper Alloy	Gold or Silver Plate
4	Shell	Aluminum Alloy	Nickel Plate
5	Barrel	Aluminum Alloy	Nickel Plate
6	Socket Contact	Copper Alloy	Gold or Silver Plate
7	Spring	Stainless Steel	Black Oxide
8	Screw	Steel	Nickel Plate
9	Coupling Nut	Aluminum Alloy	Nickel Plate
10	End Bell	Aluminum Alloy	Nickel Plate
11	Ground Nut/ Clamp Saddle	Aluminum Alloy	Nickel Plate
12	Screw	Steel	Nickel Plate
13	Bushing	Rubber	—

GT/D Series Connectors

BOX MOUNTING RECEPTACLE GT/D2A

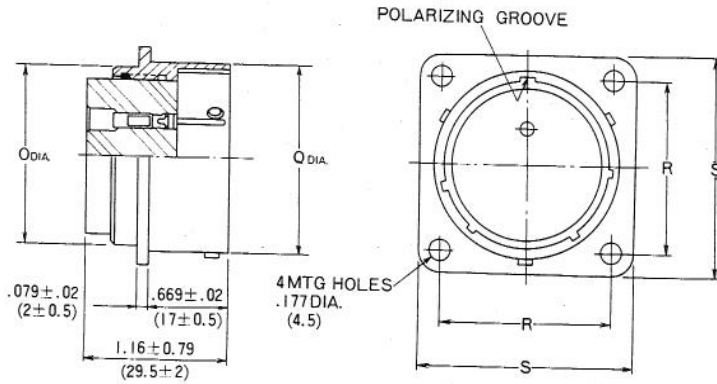
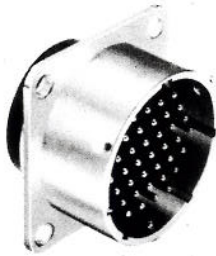

Mating half: GT/D6A & GT/D8A

Part Number	Inches				Millimeters			
	R	S	Q Dia.	O Dia.	R	S	Q Dia.	O Dia.
GT/D2A-12-M4*C-FO	±.008	±.031	±.02	±.031	±0.2	±0.8	±0.5	±0.8
GT/D2A-16-M8*C-FO	.807	1.161	.748	.709	20.5	29.5	19	18
GT/D2A-18-M12*C-FO	.965	1.319	1.000	.945	24.5	33.5	25.4	24
GT/D2A-22-M31*C-FO	1.063	1.417	1.126	1.063	27	36	28.6	27
GT/D2A-24-M37*C-FO	1.260	1.614	1.378	1.299	32	41	35	33
GT/D2A-28-M55*C-FO	1.378	1.732	1.496	1.417	35	44	38	36
	1.654	2.087	1.811	1.732	42	53	46	44

* Contact Type (P for Pin, S for Socket)

STRAIGHT PLUG SOLID ENDBELL WITH CABLE CLAMP GT/D6A



GT/D6A is attached to cable end. When terminated contacts are installed, it is necessary to remove from plug or receptacle and slip over wire bundle in proper order for reassembly.

Mating half: GT/D2A

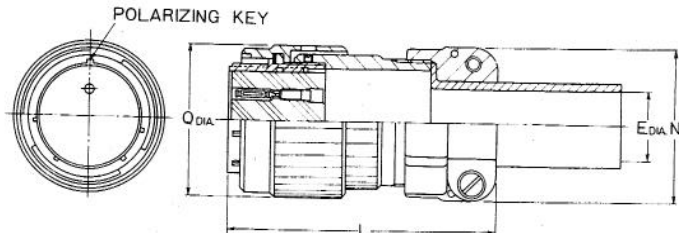

Part Number	Inches				Millimeters			
	L	N	Q Dia.	E Dia.	L	N	Q Dia.	E Dia.
GT/D6A-12-M4*C-A-(11)-FO	±.197	±.031	±.031	±.031	±5	±0.8	±0.8	±0.8
GT/D6A-16-M8*C-A-(14)-FO	2.953	1.142	1.063	.433	75	29	27	11
GT/D6A-18-M12*C-A-(16)-FO	2.953	1.260	1.339	.571	75	32	34	14.5
GT/D6A-22-M31*C-A-(20)-FO	2.953	1.457	1.457	.630	75	37	37	16
GT/D6A-24-M37*C-A-(24)-FO	2.953	1.693	1.693	.807	75	43	43	20.5
GT/D6A-28-M55*C-A-(31)-FO	2.453	2.008	1.811	.945	75	51	46	24
	3.031	2.264	2.126	1.240	77	57.5	54	31.5

* Contact Type (P for Pin, S for Socket)

CRIMP TYPE CONTACTS

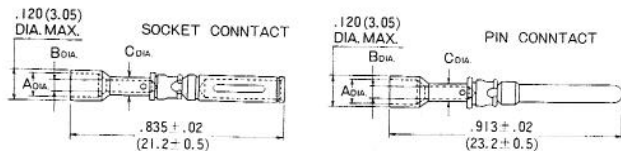

Materials/Finishes

Contact: Copper Alloy (Gold or silver over Nickel plate)

Clip: Copper Alloy (silver plate)

Spring (socket): Copper Alloy (Gold over Copper plate)

GT/D Series Connectors

90° ANGLE PLUG
SPLIT ENDBELL WITH CABLE CLAMP
GT/D8B

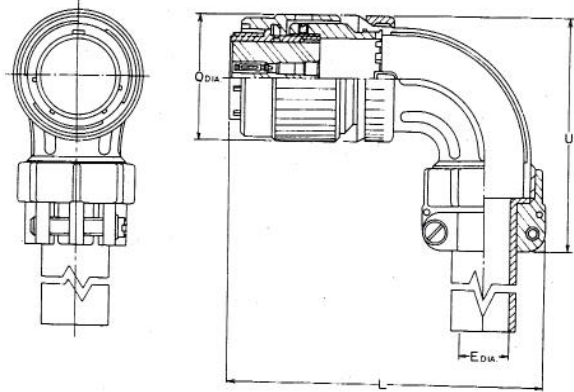

GT/D8B is a 90° angle plug and is recommended to be used where space and direction of cable entry are limited.
 Mating half: GT/D2A

Part Number	Inches				Millimeters			
	Q Dia.	L	U	E Dia.	Q Dia.	L	U	E Dia.
GT/D8A-12-M4*C-A-(11)-FO	±.031	±.315	±.197	±.031	±0.8	±8	±5	±0.8
GT/D8A-16-M8*C-A-(14)-FO	1.181	3.268	2.323	.433	30	83	59	11
GT/D8A-18-M12*C-A-(16)-FO	1.339	3.386	2.520	.571	34	86	64	14.5
GT/D8A-22-M31*C-A-(20)-FO	1.457	3.701	2.638	.630	37	94	67	16
GT/D8A-24-M37*C-A-(24)-FO	1.713	4.075	2.913	.807	43.5	103.5	74	20.5
GT/D8A-28-M55*C-A-(31)-FO	2.165	4.390	3.602	.945	55	111.5	91.5	24
	2.402	4.567	3.917	1.240	61	116	99.5	31.5

* Contact Type (P for Pin, S for Socket)

DUST CAP

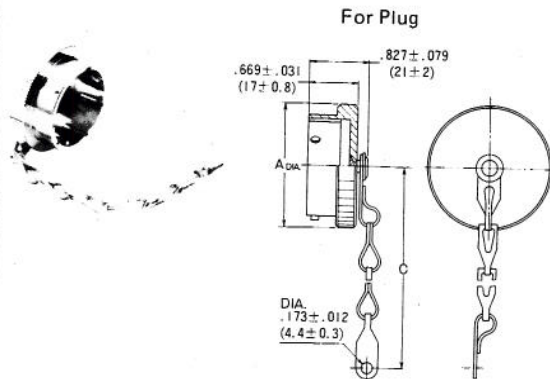
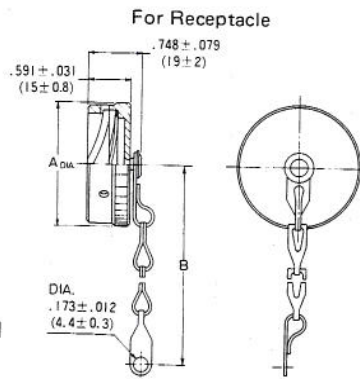

Materials/Finishes
 Cap: Aluminum Alloy (nickel plate)
 Chain assembly: Stainless steel
 Spring (GT/D43 only): Steel

Fits Shell Size	Part Number		Inches			Millimeters		
	For Receptacles	For Plugs	A	B	C	A	B	C
12	GT/D43-12C	GT/D42-12C	±.031	±.787	±.787	±0.8	±20	±20
16	GT/D43-16C	GT/D42-16C	1.063	3.937	5.118	27	100	130
18	GT/D43-18C	GT/D42-18C	1.339	3.937	5.118	34	100	130
22	GT/D43-22C	GT/D42-22C	1.457	3.937	5.118	37	100	130
24	GT/D43-24C	GT/D42-24C	1.693	4.528	5.709	43	115	145
28	GT/D43-28C	GT/D43-28C	1.811	4.528	5.709	46	115	145
			2.126	4.528	5.709	54	115	145

CRIMP TYPE CONTACTS

Contact Size	Part Number ** (Gold plating)		Applicable Wire Size			Clip Color	A Dia. ±.008 (±0.2)	B Dia. ±.008 (±0.2)	C Dia. ±.008 (±0.2)
	Pin contact	Socket contact	AWG	Conductor Cross-section Area	Overall dia. including Insulation				
16-14*	031-50793	031-50794	#14 ~ #16	2 ~ 1.25mm ²	.094 (2.4) max.	silver	.098 (2.5)	.083 (2.1)	.114 (2.9)
16-16	031-50565	031-50675	#16 ~ #20	1.25 ~ 0.5mm ²	.094 (2.4) max.	blue	0.98 (2.5)	.069 (1.75)	.110 (2.8)
16-20A	031-50566	031-50676	#20 ~ #24	0.5 ~ 0.2mm ²	.102 (2.6) max.	green	.106 (2.7)	.047 (1.20)	.071 (1.8)
16-20	031-50567	031-50677	#20 ~ #24	0.5 ~ 0.2mm ²	.063 (1.6) max.	red	.067 (1.7)	.047 (1.20)	.071 (1.8)

* Contact size 16-14 is applicable only for insert arrangements 12-M4, 16-M8 & 18-M12.
 ** Silver plated contacts are also available (-001 is added to the end of part number.)

Crimping & Contact Insertion/Extraction Tools

HAND CRIMP TOOL

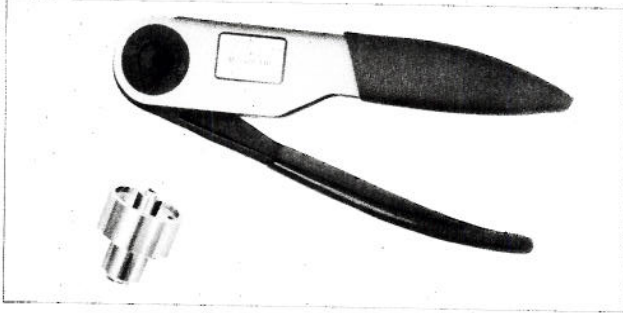

Tool: M22520/1-01
Locator: JP-QE-16-16
Manually operated termination is made by assembling a locator (order separately) to the tool.

INSERTION TOOL

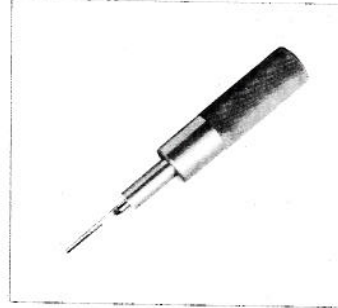

Tool: JIT-QE-16
Use when hard to insert contacts by hand.

EXTRACTION TOOL



Tool: JET-16
Contacts can be extracted from the rear by inserting the tool from mating face of connectors.

APPLICABLE WIRE SIZE

Contact Size	Part Number		APPLICABLE WIRE SIZE		
	Pin Contacts	Socket Contacts	Size (AWG)	Conductor Cross-sectional Area (mm ²)	Overall dia. including insulation
16-14	031-50793	031-50794	#14 ~ #16	2 ~ 1.25mm ²	.094 (2.4) max.
16-16	031-50565	031-50675	#16 ~ #20	1.25 ~ 0.5mm ²	.094 (2.4) max.
16-20A	031-50566	031-50676	#20 ~ #24	0.5 ~ 0.2mm ²	.102 (2.6) max.
16-20	031-50567	031-50677	#20 ~ #24	0.5 ~ 0.2mm ²	.063 (1.6) max.

Termination Procedures

1 Check for Locator

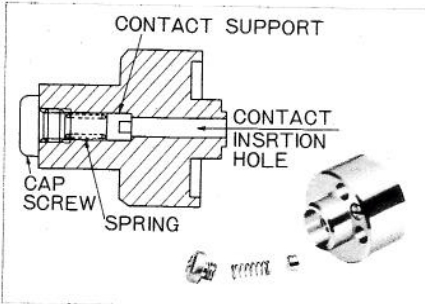

Check direction of the contact accepting rest assembled inside of the locator.

2 Locator Assembly

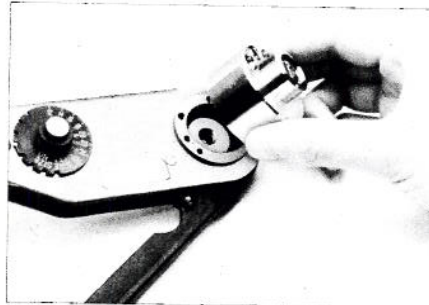

Assemble the locator on the tool by pushing along with a guide pin and fasten with two screws.

3 Check on Tool

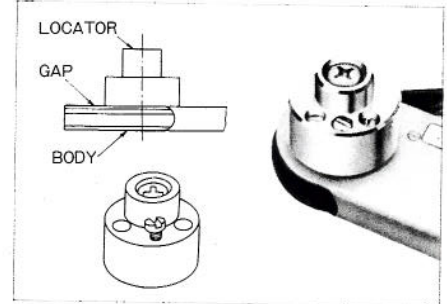

For gap and inclination between the tool and locator, adjust by the screw between two mounting screws.

5 Stripping

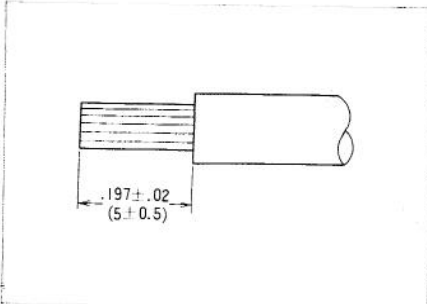

Stripping of cable insulator must be as per above dimension. Check scratch and cut of conductor.

6 Open the handles



Squeeze handles fully and release, and the handles will automatically return to full open position.

7 Contact Insertion

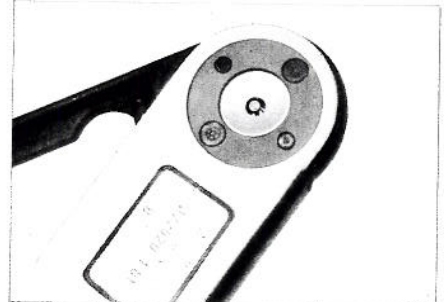

Insert the contact headed by the contacting portion into the crimping cavity of the locator.

GT/D Series Connectors

Disassembly & Assembly of Connector/Contact Insertion

For contact assembly for a straight plug (6A type), contacts will be inserted into the insulator after cable is passed through component parts.

1. Disassembly of connector: Loosen a holding screw on coupling nut, which tentatively fixes end bell to connector, and release the end bell.
2. Pass the terminated contacts through cable clamp, end bell and coupling nut.
3. Insert into the contact cavity from rear of the insulator and complete assembly by a click sound.
4. Fix the end bell, cable clamp and saddle by tightening up holding screw.

Same procedures as above are applicable for an angle plug (8B type).

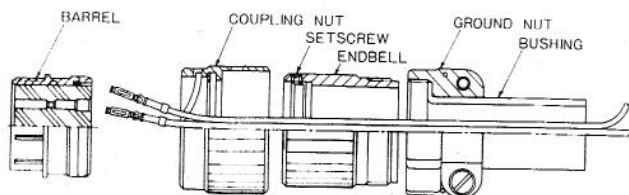

Contact Extraction (Front Release)

Insert the extraction tool gradually from front side of the insulator and then the tool tip will hit the contact clip. By further pushing, the clip will be narrowed and the spring force of the tool will push back the contact to the rear side.

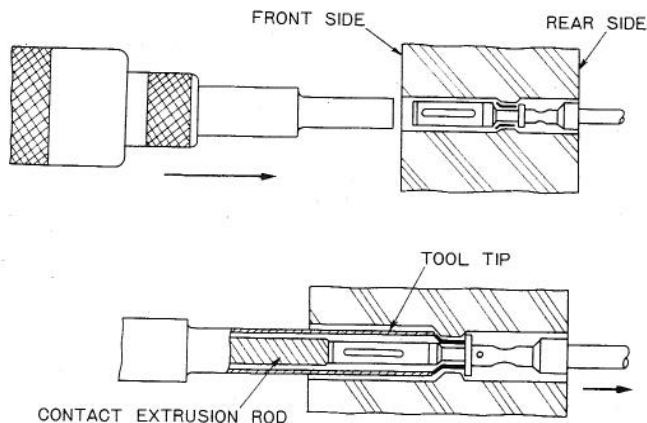

4 Setting of Selector No.



Set the selector number according to contacts and wire sizes. Rotate the selector knob by slightly pulling upward.

8 Wire Insertion

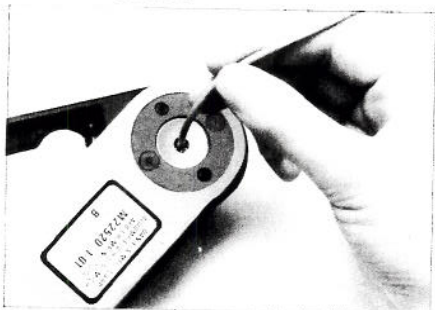

Insert fully the stripped end of wire into the terminating hole of the contact.

9 Crimping



While holding wire in position, squeeze tool handles completely until the crimp indentors are fully actuated. Crimp is completed.

Dimensions of mounting holes for receptacle

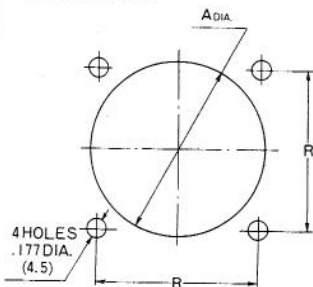

Panel thick for rear mount:
.157 (4 mm) max.

Inches

Shell Size	A Dia.	R ± .008
12	.866 ^{+0.02} ₋₀	.807
16	1.102 ^{+0.02} ₋₀	.965
18	1.240 ^{+0.02} ₋₀	1.063
22	1.496 ^{+0.039} ₋₀	1.260
24	1.614 ^{+0.039} ₋₀	1.378
28	1.929 ^{+0.039} ₋₀	1.693

Millimeters

Shell Size	A Dia.	R ± 0.2
12	22 ^{+0.5} ₋₀	20.5
16	28 ^{+0.5} ₋₀	24.5
18	31.5 ^{+0.5} ₋₀	27
22	38 ⁺¹ ₋₀	32
24	41 ⁺¹ ₋₀	35
28	49 ⁺¹ ₋₀	42



Компания «ЭлектроПласт» предлагает заключение долгосрочных отношений при поставках импортных электронных компонентов на взаимовыгодных условиях!

Наши преимущества:

- Оперативные поставки широкого спектра электронных компонентов отечественного и импортного производства напрямую от производителей и с крупнейших мировых складов;
- Поставка более 17-ти миллионов наименований электронных компонентов;
- Поставка сложных, дефицитных, либо снятых с производства позиций;
- Оперативные сроки поставки под заказ (от 5 рабочих дней);
- Экспресс доставка в любую точку России;
- Техническая поддержка проекта, помощь в подборе аналогов, поставка прототипов;
- Система менеджмента качества сертифицирована по Международному стандарту ISO 9001;
- Лицензия ФСБ на осуществление работ с использованием сведений, составляющих государственную тайну;
- Поставка специализированных компонентов (Xilinx, Altera, Analog Devices, Intersil, Interpoint, Microsemi, Aeroflex, Peregrine, Syfer, Eurofarad, Texas Instrument, Miteq, Cobham, E2V, MA-COM, Hittite, Mini-Circuits, General Dynamics и др.);

Помимо этого, одним из направлений компании «ЭлектроПласт» является направление «Источники питания». Мы предлагаем Вам помощь Конструкторского отдела:

- Подбор оптимального решения, техническое обоснование при выборе компонента;
- Подбор аналогов;
- Консультации по применению компонента;
- Поставка образцов и прототипов;
- Техническая поддержка проекта;
- Защита от снятия компонента с производства.



Как с нами связаться

Телефон: 8 (812) 309 58 32 (многоканальный)

Факс: 8 (812) 320-02-42

Электронная почта: org@eplast1.ru

Адрес: 198099, г. Санкт-Петербург, ул. Калинина, дом 2, корпус 4, литера А.