

REV	DOCUMENT	CHANGED BY	CHECK
14	0038162	BS 24MAR08	ASD

**SERIES** **CPC** **G**

**DESIGNATES PRESSURE**  
**L** - LOW PRESSURE (IN H<sub>2</sub>O)  
 - NO DESIGNATION (PSI)

**ACCURACY GRADE**  
**C** - COMMERCIAL GRADE  
**H** - HIGH GRADE

**PORT OPTION**  
**F** - AXIAL  
 - NO PORT/O-RING SEAL

**PRESSURE RANGE**  
**04, 10** IN H<sub>2</sub>O  
**0.3, 01, 05, 15, 30,**  
**60, 100, 150** PSI

**PRESSURE REFERENCE**  
**G** - GAGE

CATALOG LISTINGS	
CPCL04GC	CPC15GFC
CPCL04GFC	CPC15GFH
CPCL10GFC	⑨
CPCL10GFH	CPC30GFC
CPCL10GH	CPC30GFH
⑩	CPC60GFH
CPC0.3GFC	⑨
CPC0.3GFH	CPC60GFC
CPC01GFC	CPC100GFH
CPC01GFH	CPC100GC
CPC01GH	CPC100GFC
CPC05GC	CPC150GFC
CPC05GFC	CPC150GFH
CPC05GFH	SCDA121 CPCL04GFC
CPC05GH	

G - STYLE (GAGE)	PERFORMANCE AT 25°C AND 12±0.01 Vdc (UNLESS OTHERWISE STATED)						UNITS	FULL SCALE PRESSURE PSI	OVER PRESSURE PSI
	C-GRADE			H-GRADE					
	MIN	NOM	MAX	MIN	NOM	MAX			
NULL OFFSET (0 PSIG) (L04 LISTING)	-2	0	2	N/A	N/A	N/A	mV		
NULL OFFSET (0 PSIG), ALL LISTINGS EXCEPT L04	-1	0	1	-0.5	0	0.5	mV		
4 IN H <sub>2</sub> O (P1>P2) (L04 LISTING)	23	25	27	N/A	N/A	N/A	mVdc	4 IN H <sub>2</sub> O 3	
4 IN H <sub>2</sub> O (P1>P2) (SCDA121 CPCL04GFC)	23	25	27	N/A	N/A	N/A	mVdc	4 IN H <sub>2</sub> O 5	
10 IN H <sub>2</sub> O (P1>P2) (L10 LISTING)	19	20	21	19.5	20	20.5	mVdc	10 IN H <sub>2</sub> O 5	
0.3 PSI SPAN (P1>P2)	19	20	21	19.5	20	20.5	mVdc	0.3 5	
1 PSI SPAN (P1>P2)	17	18	19	17.5	18	18.5	mVdc	1 5	
5 PSI SPAN (P1>P2)	57	60	63	59	60	61	mVdc	5 15	
15 PSI SPAN (P1>P2)	85	90	95	89	90	91	mVdc	15 45	
30 PSI SPAN (P1>P2)	85	90	95	89	90	91	mVdc	30 90	
60 PSI SPAN (P1>P2)	85	90	95	89	90	91	mVdc	60 180	
100 PSI SPAN (P1>P2)	95	100	105	99	100	101	mVdc	100 250	
150 PSI SPAN (P1>P2)	85	90	95	89	90	91	mVdc	150 250	
NULL SHIFT OVER TEMPERATURE (0-25, 25-70 °C) <sup>2</sup> / <sub>10</sub>	---	---	±1	---	---	±.5	mV		
SPAN SHIFT OVER TEMPERATURE (0-25, 25-70 °C) <sup>2</sup> / <sub>10</sub>	---	---	±2	---	---	±1	% SPAN		
COMBINED LINEARITY AND HYSTERESIS <sup>3</sup>	---	0.25	1	---	0.25	0.5	% SPAN		

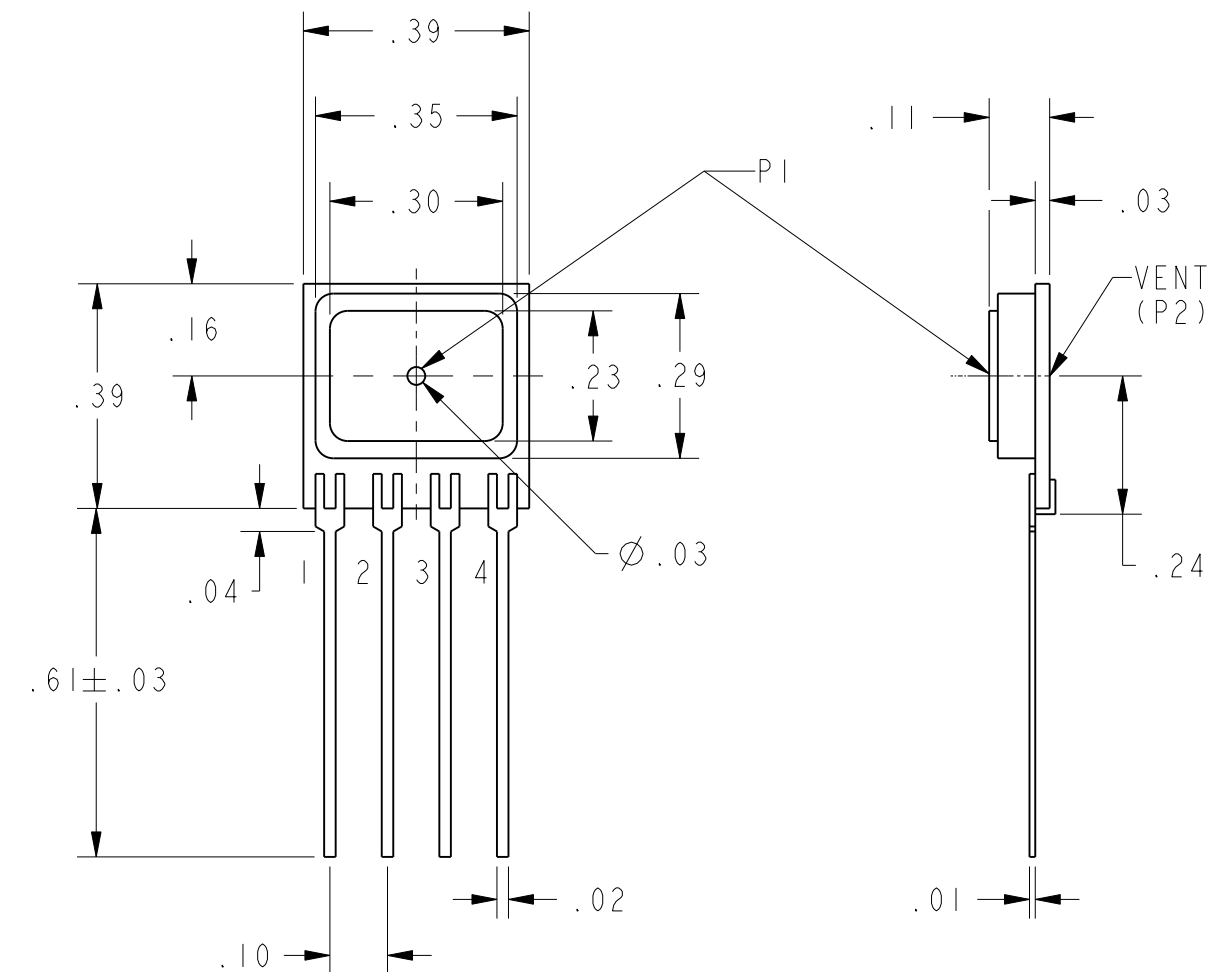

G HOUSING

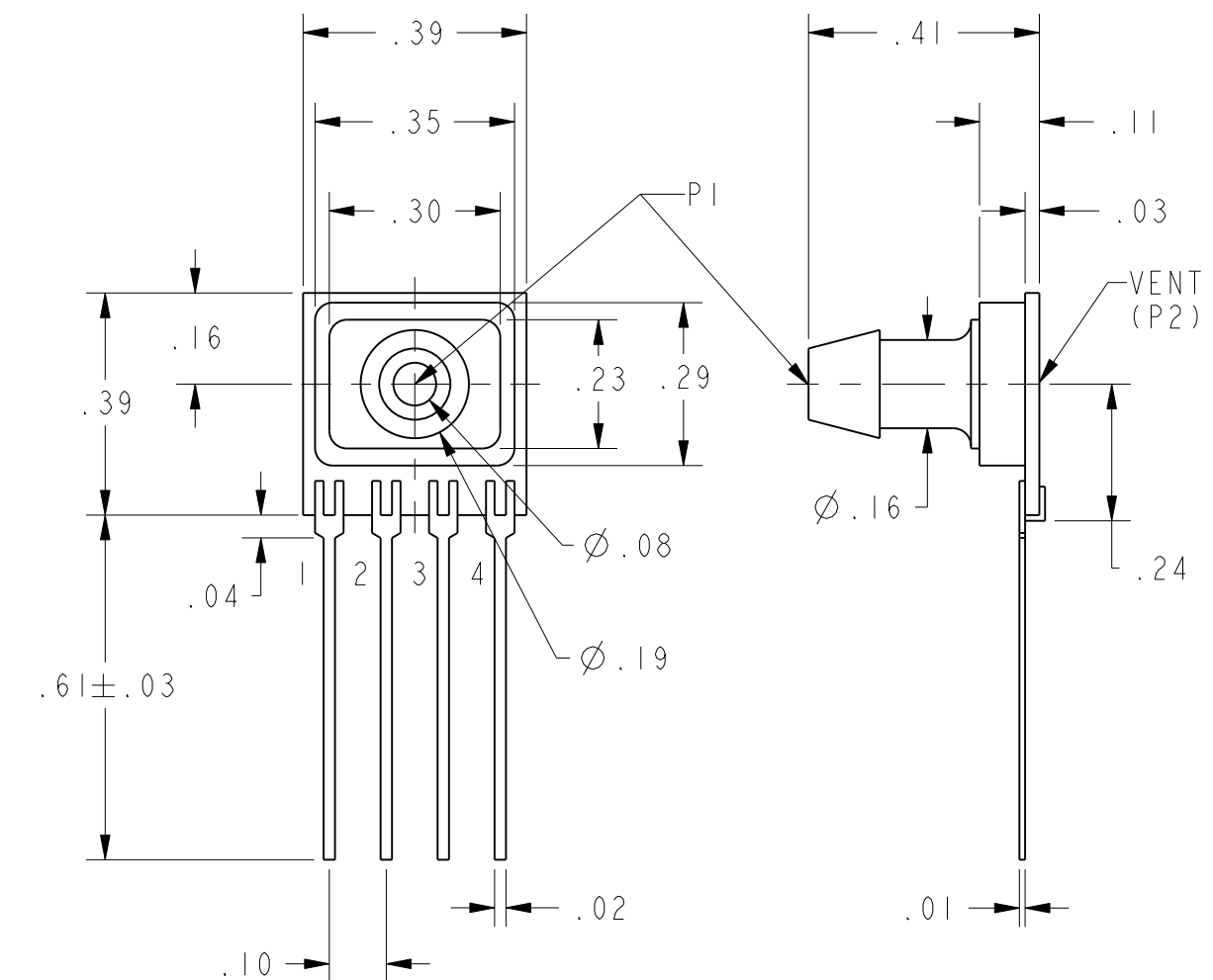

GF HOUSING

GENERAL OPERATING CHARACTERISTICS	ALL PRESSURES AND GRADES			UNITS
	MIN	NOM	MAX	
EXCITATION VOLTAGE	3	12	16	Vdc
SUPPLY CURRENT	---	---	3.5	mA
INPUT RESISTANCE	5	---	---	K-OHMS
OUTPUT RESISTANCE	---	3	---	K-OHMS
OPERATING TEMPERATURE	-25	---	85	°C
STORAGE TEMPERATURE	-40	---	125	°C

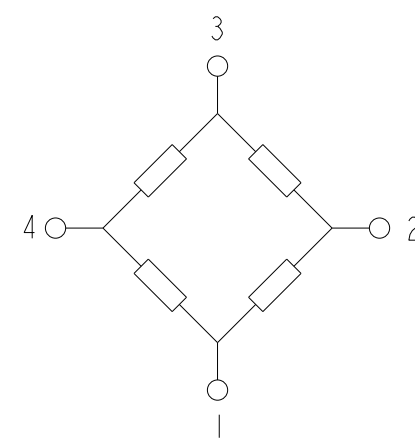

EQUIVALENT CIRCUIT

PIN OUT	
1	-V EXCITATION
2	+ OUTPUT SIGNAL
3	+ V EXCITATION
4	- OUTPUT SIGNAL

NOTES

- 1 - SPAN IS THE ALGEBRAIC DIFFERENCE BETWEEN THE OUTPUT AT FULL SCALE PRESSURE AND THE OFFSET OUTPUT
- <sup>2</sup> TEMPERATURE ERROR IS CALCULATED WITH RESPECT TO 25°C
- <sup>3</sup> LINEARITY IS MEASURED AT 1/2 FULL SCALE PRESSURE USING BEST STRAIGHT LINE FIT
- 4 - THE OUTPUT OF THE SENSOR IS PROPORTIONAL, RATIOMETRIC, TO THE EXCITATION VOLTAGE. THE EXCITATION MAY VARY BETWEEN 3 TO 16 Vdc. ALL SPECIFICATIONS WILL NOMINALLY BE CHANGED BY THE RATIO OF V<sub>EXCITATION</sub>/12.0 Vdc
- 5 - LIMIT SOLDERING TO 315°C FOR LESS THAN 10 SECONDS
- 6 - PIN 1 IS IDENTIFIED BY THE DOT ON THE HOUSING AS SHOWN ON THE VARIOUS DRAWINGS
- 7 - APPLY PRESSURE TO PORT INDICATED ON THE DRAWINGS SHOWN
- 8 - SENSORS ARE OPERATIONAL OVER VACUUM PRESSURE RANGE
- 9 - INPUT MEDIA RESTRICTED TO DRY GASES ONLY
- <sup>10</sup> THE L04 LISTING HAS A TEMPERATURE SHIFT RANGE FROM 0 TO 25°C AND 25 TO 50°C

UNLESS OTHERWISE SPECIFIED TOLERANCES ARE:	<input checked="" type="checkbox"/> US (inch) CUSTOMARY	<input type="checkbox"/> SI (mm) METRIC	DRAWN	TRF	02APR01	<b>Honeywell</b>		
NO PLACE	X	±.040 ±1	CHECK	SAV	02APR01			
ONE PLACE	.X	±.030 ±0,4	THIS DRAWING COVERS A PROPRIETARY ITEM AND IS THE PROPERTY OF HONEYWELL. THIS DRAWING IS NOT TO BE COPIED OR USED WITHOUT THE PERMISSION OF HONEYWELL.			TITLE		
TWO PLACE	.XX	±.015 ±0,15				<b>PRESSURE SENSOR</b>		
THREE PLACE	.XXX	±.005 ±				SIZE	DWG TYPE	DRAWING NAME
ANGLES	±	±				<b>C</b>	<b>I</b>	<b>CPC GAGE SERIES CHART 1 14</b>
RAW MATERIAL-COMMERCIAL STANDARD	±	±	3D PTC	ASME Y14.5M-1994	SCALE	3:1		
THIRD ANGLE PROJECTION			DIMENSIONS ARE TO BE MET BEFORE PROTECTIVE COATINGS ARE APPLIED			WEIGHT		
			SHEET			1 OF 1		



Компания «ЭлектроПласт» предлагает заключение долгосрочных отношений при поставках импортных электронных компонентов на взаимовыгодных условиях!

Наши преимущества:

- Оперативные поставки широкого спектра электронных компонентов отечественного и импортного производства напрямую от производителей и с крупнейших мировых складов;
- Поставка более 17-ти миллионов наименований электронных компонентов;
- Поставка сложных, дефицитных, либо снятых с производства позиций;
- Оперативные сроки поставки под заказ (от 5 рабочих дней);
- Экспресс доставка в любую точку России;
- Техническая поддержка проекта, помощь в подборе аналогов, поставка прототипов;
- Система менеджмента качества сертифицирована по Международному стандарту ISO 9001;
- Лицензия ФСБ на осуществление работ с использованием сведений, составляющих государственную тайну;
- Поставка специализированных компонентов (Xilinx, Altera, Analog Devices, Intersil, Interpoint, Microsemi, Aeroflex, Peregrine, Syfer, Eurofarad, Texas Instrument, Miteq, Cobham, E2V, MA-COM, Hittite, Mini-Circuits, General Dynamics и др.);

Помимо этого, одним из направлений компании «ЭлектроПласт» является направление «Источники питания». Мы предлагаем Вам помощь Конструкторского отдела:

- Подбор оптимального решения, техническое обоснование при выборе компонента;
- Подбор аналогов;
- Консультации по применению компонента;
- Поставка образцов и прототипов;
- Техническая поддержка проекта;
- Защита от снятия компонента с производства.



#### Как с нами связаться

**Телефон:** 8 (812) 309 58 32 (многоканальный)

**Факс:** 8 (812) 320-02-42

**Электронная почта:** [org@eplast1.ru](mailto:org@eplast1.ru)

**Адрес:** 198099, г. Санкт-Петербург, ул. Калинина, дом 2, корпус 4, литера А.