

EMOSAFE EN-50

Network Isolators for Panel Mounting

Product Datasheet

December 2015



1 FEATURES AND ADVANTAGES

- Compact
- Option of either horizontal or vertical internal connection
- Equalisation of potential voltage differences, plus electrostatic discharge protection
- Gigabit Ethernet
- 4 kV AC dielectric strength
- 5.6 kV DC dielectric strength
- Conforms to IEC 60601-1 (3rd Edition)
- 100% inspection by our Quality Control
- UL Recognized Component
- RoHS compliant
- Optional contact protection
- Optional quick connect system for frequently connected / disconnected mobile devices (Y-Con®)

2 GENERAL DESCRIPTION

EMOSAFE EN-50 Network Isolators disconnect every electrically conducting connection (specifically the data and shield conductors) between devices connected together via a copper-based Ethernet network. The Network Isolators prevent current flow resulting from differences in electrical potentials, and also protect connected devices and their users from stray external voltages and power surges which may be directly or inductively coupled onto the network lines by causes such as installation errors, lightning, switching operations, and electrostatic discharge.

Built into a medical electrical (ME) product, the EMOSAFE EN-50 Network Isolator facilitates the safe Ethernet connection of this ME product within the patient environment. The EN-50 satisfies all construction requirements of IEC 60601-1 (3rd Edition) in the formation of two means of patient protection (MOPP) within the network interface, thereby practically eliminating the risk of electrical shocks arising from such stray external voltages at the network connection.

Conventional Network Isolators, which also create an electrical separation of the cable shielding, present the electromagnetic problem of radiant energy leaking from the panel housing opening, which can in turn lead to difficulties for electromagnetic compliance (EMC) testing. Devices and cables attached to ungrounded Ethernet interfaces can hereby be the cause of electromagnetic disturbances. To avoid this problem, the EN-50 series of Network Isolators provides an electrical connection to the otherwise separated earth connection via an integrated resistor network and parallel Y-Class capacitors. This results in a greatly reduced risk of radiated and received electromagnetic interference, without compromising the protective effect of the Network Isolator. With its highly resistive shielding connection, the EN-50 also enables the slow and gentle equalisation of potential voltage differences.

The EN-50 is further distinguished by its gigabit Ethernet capability and its robust construction. The optional Yamaichi Y-Con® connection system simplifies the plugging and unplugging process, increases the mechanical restraining strength, and also reduces the risk of accidental human contact of the conductive surfaces, thus reducing the risk of potentially dangerous electrical discharge through the ME operator or the patient. The Y-Con® connection is also fully compatible with conventional Ethernet connectors.

As UL Recognized Components, the EN-50 Network Isolators are also suitable for inclusion in devices destined for export in the North American markets. All variants of the EN-50 family can be ordered with the internal Ethernet connection in either a horizontal (H), or a 90° vertical (V) configuration.

EMOSAFE Network Isolators transmit high-frequency signals through the principle of electromagnetic induction. Because of this, they do not require their own power supplies. There are no software drivers to be installed.

3 APPLICATIONS

3.1 PATIENT PROTECTION

Electrical separation of Ethernet interfaces of medical electrical (ME) devices and systems, where patients must be protected from dangerous leakage currents, in conformity with applicable standards.

3.2 EQUIPMENT PROTECTION

Applications, in which valuable devices or those requiring special protection need to be protected against ripple, mains hum, and surge voltages from the network periphery.

3.3 MEASUREMENT TECHNOLOGY

Electrical measuring and monitoring equipment, which needs to be protected against external voltages and interference voltages arising from the Ethernet periphery.





3.4 AUDIO

Audio applications, in which the transmission of low frequency alternating current voltages (mains hum) over the network connection is to be reduced to an imperceptible level.

4 SUMMARY OF VARIANTS

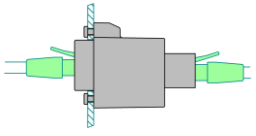
EN-50

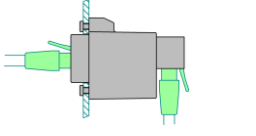
EMC-optimised Network Isolators for Panel Mounting

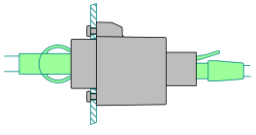
	Name Article number	Special features	AC dielectric strength in kV	Gigabit Ethernet	Typical Return Loss @ 100 MHz	Typical Insertion Loss @ 100 MHz	Configuration
	EN-50HG-S A10205	Y-Capacitors and rear-end ground terminal for electro-magnetic suppression. Horizontal internal outlet	4	✓	8 dB	1.5 dB	
	EN-50VG-S A10201	Y-Capacitors and rear-end ground terminal for electro-magnetic suppression Vertical internal outlet	4	✓	8 dB	1.5 dB	
	EN-50HG-Y A10200	As per EN-50HG-S Y-Con® connect interface for improved retaining strength and reduced accidental touch risk	4	✓	8 dB	1.5 dB	

4.1 CUSTOMER-SPECIFIC ADAPTIONS

The capacity of the Y-Class capacitors can be tailored to suit upon request, in order to address specific EMC scenarios. Please contact us, should you require customised adaptions of an EN-50.

4.2 TECHNICAL DRAWINGS: EN-50HG-S

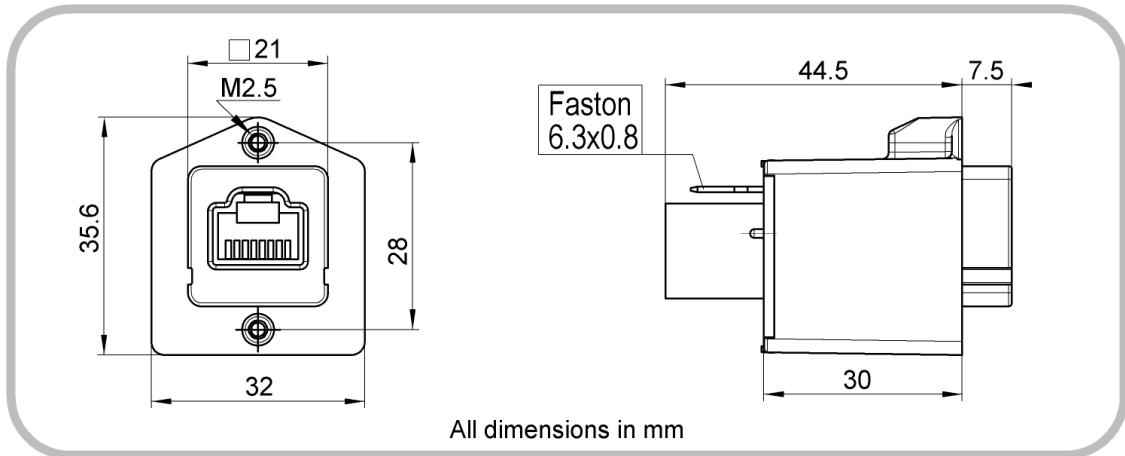

Figure 1. Physical dimensions of EN-50HG-S

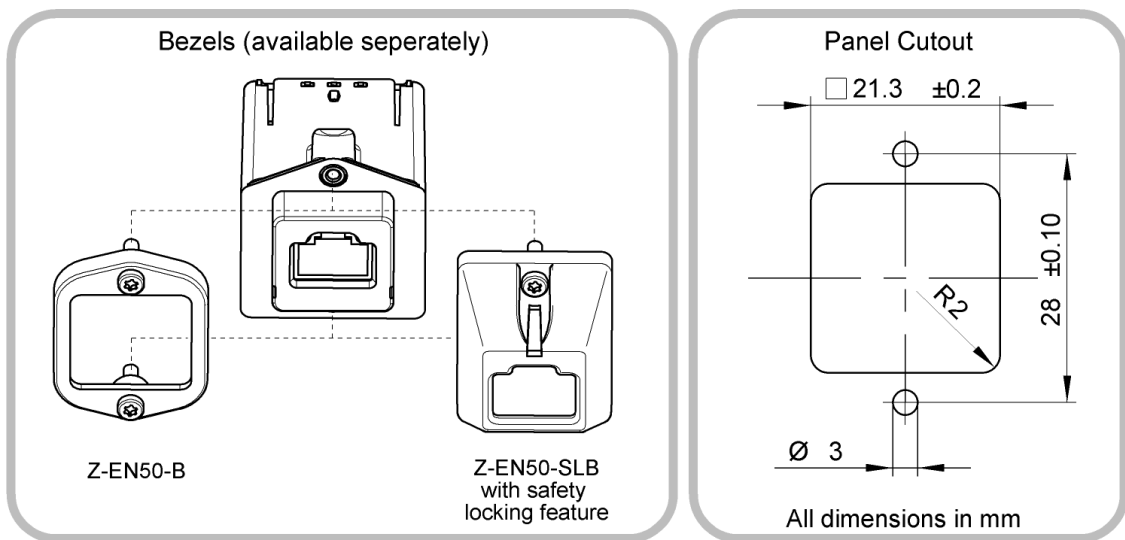

Figure 2. Optional compatible bezels for EN-50HG-S. Panel cut-out dimensions.

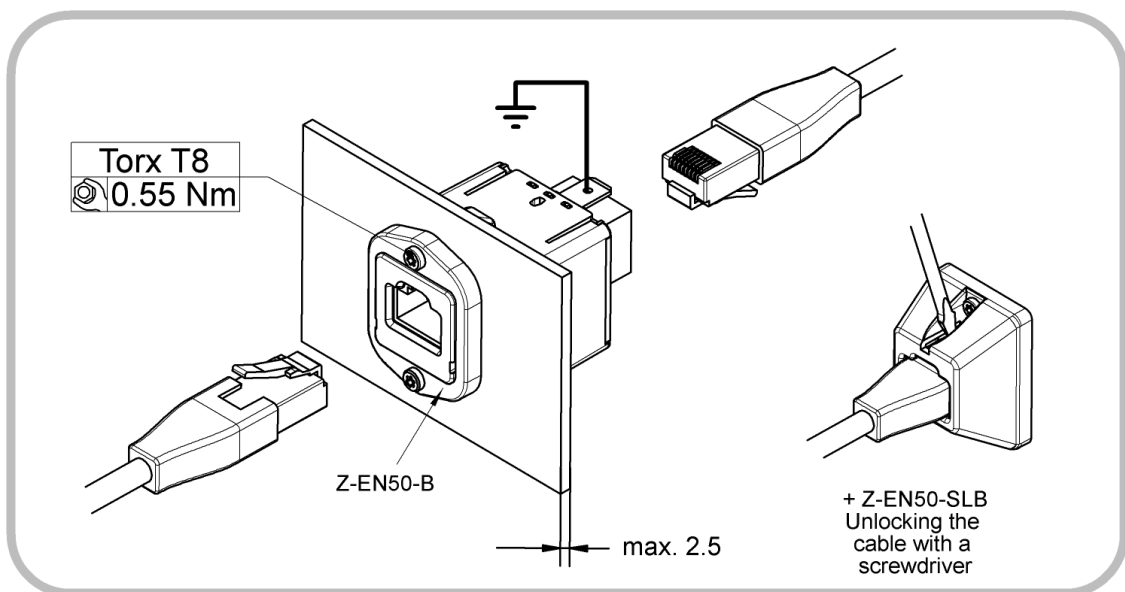

Figure 3. EN-50HG-S installation and unlocking of bezel Z-EN50-SLB.

4.3 TECHNICAL DRAWINGS: EN-50VG-S

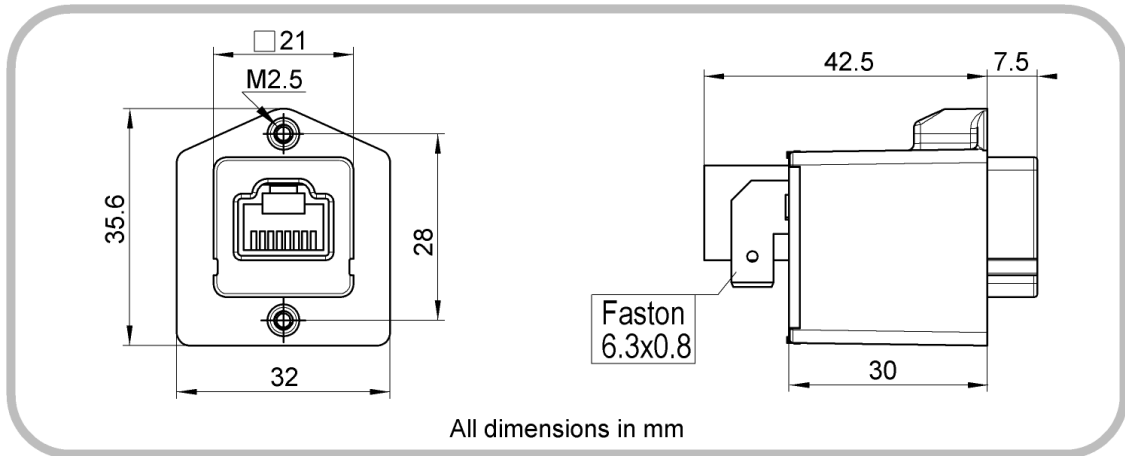

Figure 4. Physical dimensions of EN-50VG-S

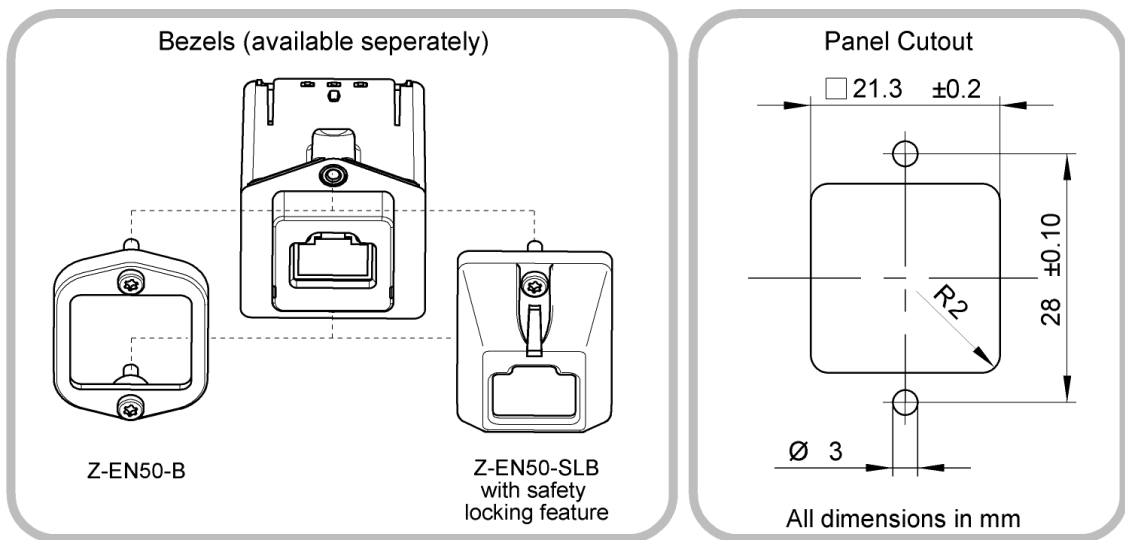

Figure 5. Optional compatible bezels for EN-50VG-S. Panel cut-out dimensions.

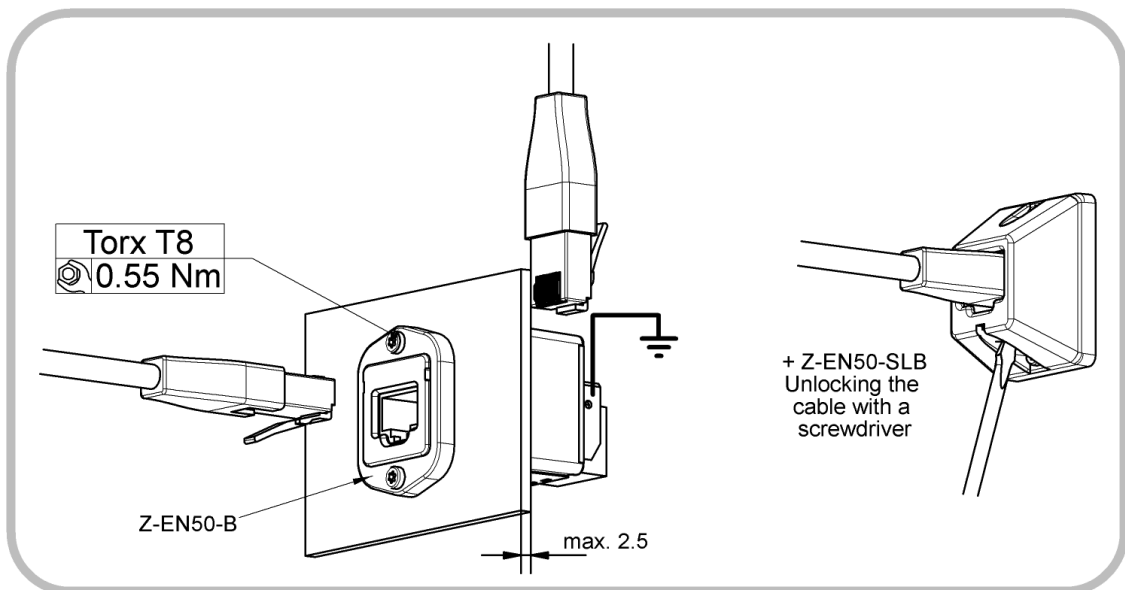

Figure 6. EN-50VG-S installation and unlocking of bezel Z-EN50-SLB.

4.4 TECHNICAL DRAWINGS: EN-50HG-Y

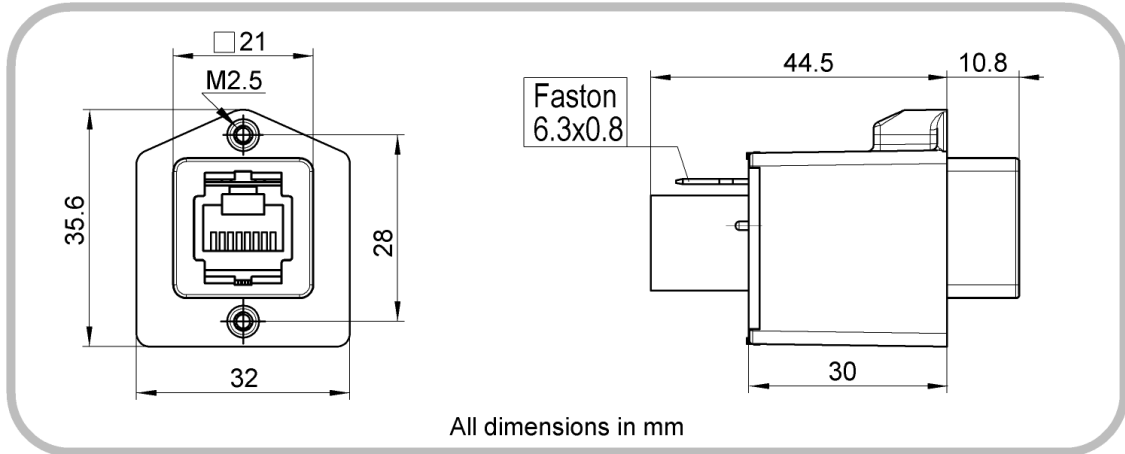

Figure 7. Physical dimensions of EN-50HG-Y

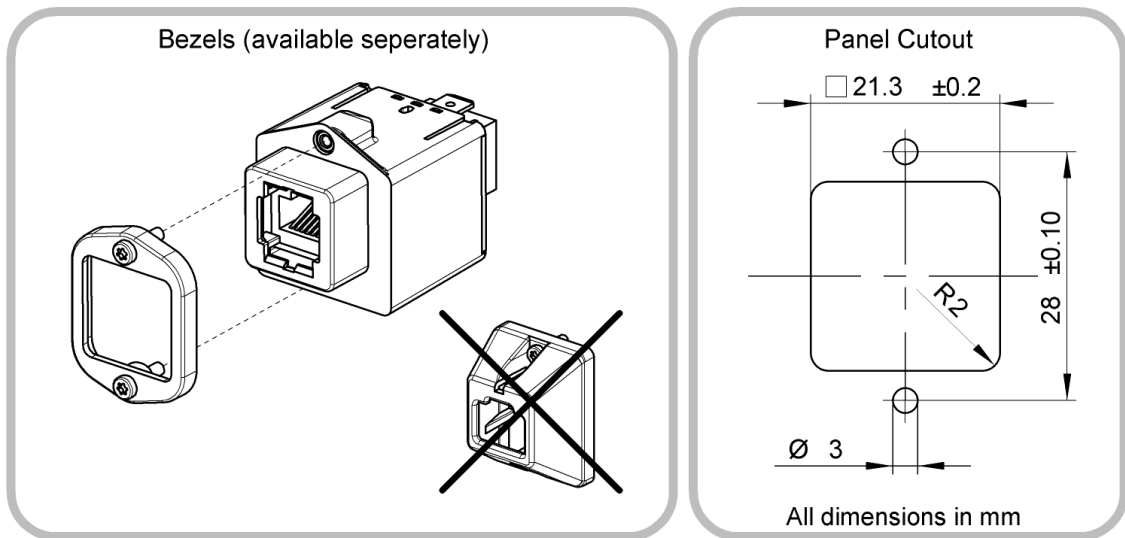

Figure 8. Optional compatible bezel for EN-50HG-Y. Panel cut-out dimensions.

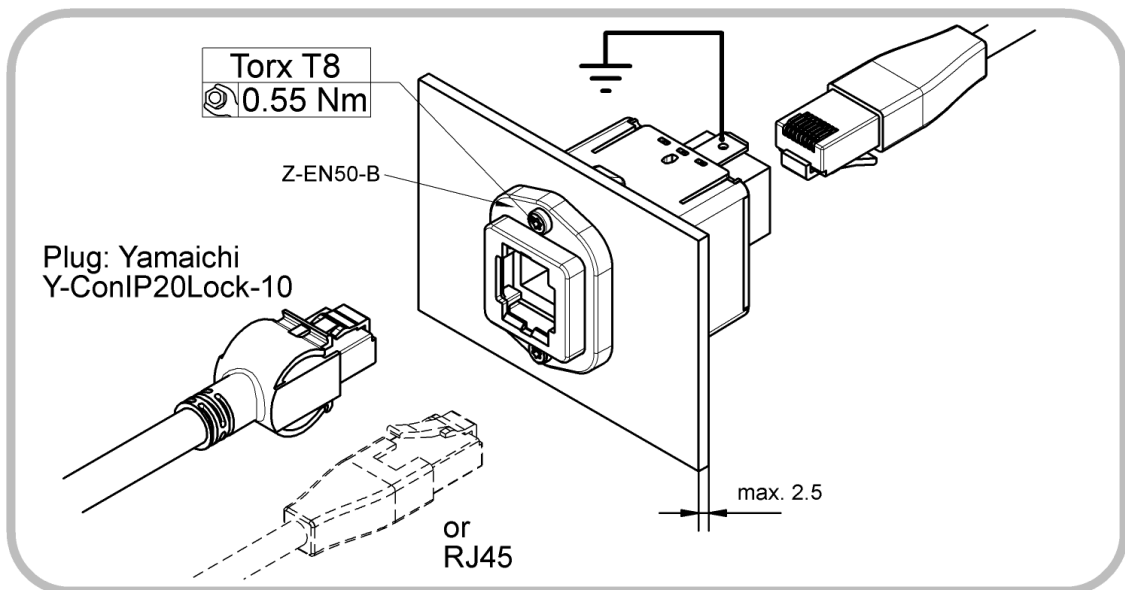

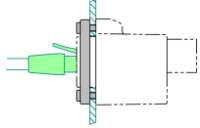

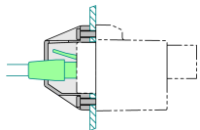
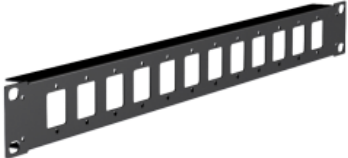

Figure 9. EN-50HG-Y installation and unlocking of bezel Z-EN50-SLB.

5 ACCESSORIES

EN-50

Accessories

	Name		Configuration
	Z-EN50-B P00396	Bezel for EN-50 Network Isolators	
	Z-EN50-SLB P00397	Safety Bezel for EN-50 Network Isolators, with touch protection and safety locking	
	Z-EN50-RP A10040	19" Patch Panel provides mounting locations for 12 × EN-50 Network Isolators. Material: matt black powder coated steel.	-

5.1 Z-EN50-B

The accessory Z-EN50-B fits each of the three variants of the EN-50. It serves to cover the panel cut-out edges, and to provide an optically appealing frame around the EN-50. It consists of the same black plastic as the EN-50.

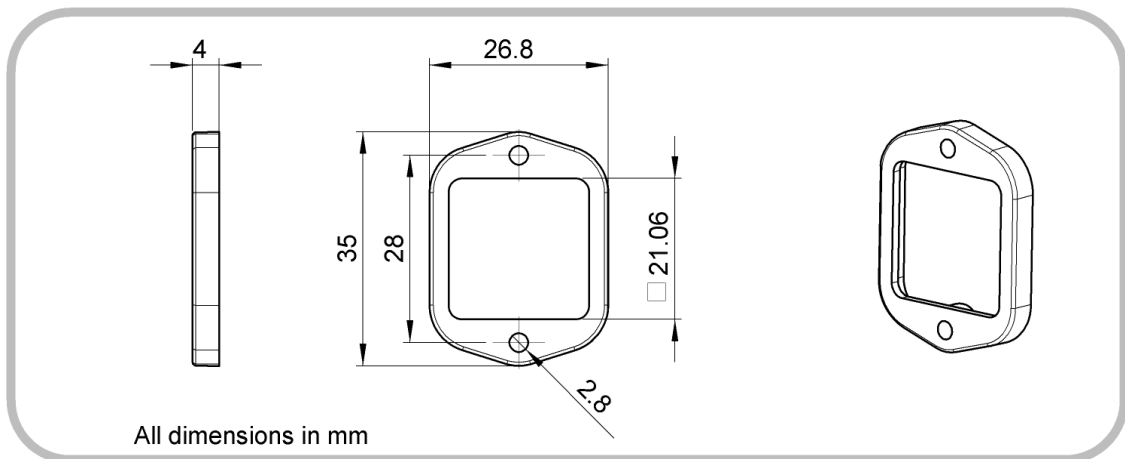

Figure 10. Physical dimensions of the bezel accessory Z-EN50-B

5.2 Z-EN50-SLB

The accessory Z-EN50-SLB fits both the EN-50HG-S and EN-50VG-S variants. It primarily serves to create an effective contact protection barrier, preventing the often uninsulated cable shielding of inserted Ethernet patch cables from coming into contact with patients or operators (which otherwise circumvents the effectiveness of the EN-50). For this reason, the simple unplugging of connected cables is additionally prevented by the Z-EN50-SLB. Removal is only possible through the use of a suitably small tool, such as a

screwdriver or pencil. This feature also assists to prevent unauthorized cable removal. It consists of the same black plastic as the EN-50.

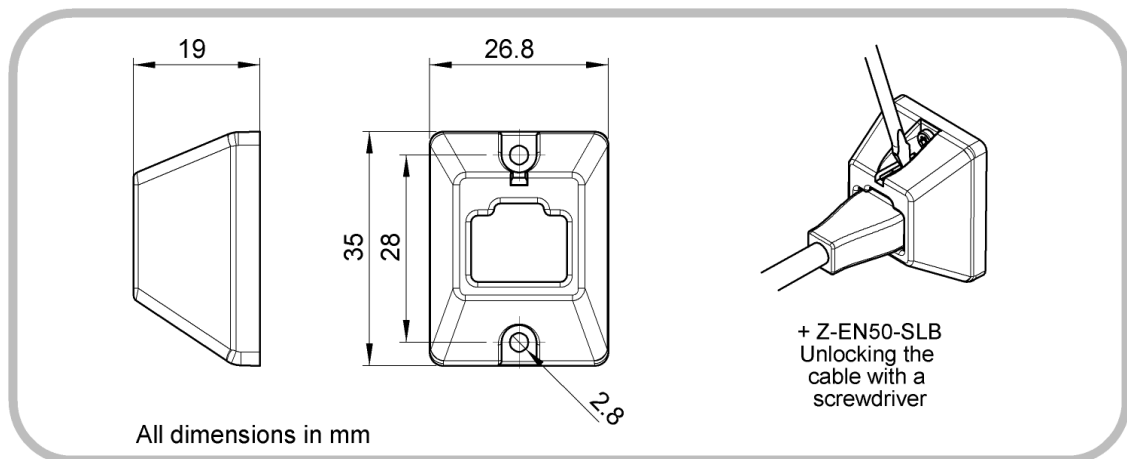

Figure 11. Physical dimensions of the safety bezel accessory Z-EN50-SLB

6 INSTALLATION INFORMATION

6.1 GENERAL

EN-50 Network Isolators are designed for data transmission in the frequency range of 300 kHz to 100 MHz. Lower frequencies are strongly attenuated. For this reason, it is generally not possible to transmit the signals from nurse call systems, telephone systems or analogue audio / video signals over a Network Isolator.

The EN-50 Network Isolator can be used in a Power over Ethernet (PoE) network without restriction (however PoE devices downstream of the electrical isolation are not supplied with power). A PoE Injector can be installed to supply downstream devices, however it is critical that this power supply meets or exceeds all applicable medical electrical requirements, in order to maintain the effectivity of the Network Isolator.

6.2 EQUIPMENT INSTALLATION

When designing Network Isolators into equipment or devices, it is essential that the manufacturer observes the applicable creepage and clearance distances. Specifically, the creepage and clearance distances between exposed metal surfaces of Ethernet patch cables plugged into the Network Isolator, and the next-closest electrically conducting components of the equipment or device to be protected. The requirements of IEC60601-1 are particularly relevant.

7 SAFETY NOTICE

During assembly, attention should be paid (when applicable) to ensure that the clearance and creepage distances required by IEC 60601-1 are met. The isolating effect of the Network Isolator must not be compromised by neighbouring conductive components. If, for example, the installation of the Network Isolator is to be within a metal plate, this plate must be connected to the ground potential (protective earth). As a matter of principle, Network Isolators should be mounted as close as possible to the equipment requiring protection.

Damaged Network Isolators, and Network Isolators which are contaminated by dust or liquids, are to be replaced.

8 FUNCTION AND SAFETY TESTS

8.1 FUNCTION AND COMPLIANCE TESTS

A cable run equipped with an EN-50 Network Isolator can be checked with regard to its transmission characteristics using cable certification devices which are suitable for testing an electrically isolated cable run. To be able to conduct such an inspection, the test equipment must be configured in an AC wire-map mode. With the installed Network Isolator, the entire cable run can be approved according to EIA/TIA-568 Cat.5e or ISO 11801 Class C. Testing of the cable shielding and the individual conductor resistance is not possible in such an AC test mode.

8.2 SAFETY INSPECTIONS

Regular safety inspections and post-repair inspections are not prescribed for Network Isolators in medical use, as Network Isolators themselves are not classified as medical electrical (ME) devices. However, together with a connected ME device, Network Isolators form part of an ME system, which altogether may be subject to statutory inspection. The test interval, as well as the requirements to be met for both regular safety inspections and post-repair inspections will be specified by the responsible organisation (e.g. manufacturer or operator as defined by the regulations), and based upon the applicable standards for the entire ME system.

To simplify implementation, the individual components of the ME system (in this case, the Network Isolator) can be tested separately. Here as well, the responsible organisation specifies the test parameters, test interval and in the event of a failed test, the consequences. Depending on the requirement profile, the test can include one or more of the following individual tests:

8.2.1 VISUAL INSPECTION

Check for evidence of external damage and ingress of substances; dust or liquids for example.

8.2.2 LEAKAGE CURRENT TEST

It is to be checked if the measured leakage current is still within the prescribed limits. For this purpose, test equipment which can perform equipment leakage current measurements in accordance with IEC 62353 may be used. To perform a leakage current test, all conductors on the input side must be short-circuited together, and all the conductors on the output side must also be short-circuited together. The AC test voltage specified by the responsible organisation is then applied across these two connections. Input and output sides are interchangeable. The expected current flow can be found in section *9 SPECIFICATIONS*.

8.2.3 HIPOT TEST

To ensure that the device under test is not damaged, it is recommended that a DC voltage source is used in place of the AC voltage source, and that the DC voltage is 1½ times that of the required AC voltage. The test setup is essentially the same as that of the Leakage Current Test above. The expected dielectric strength can be found in section *9 SPECIFICATIONS*.

8.2.4 FUNCTIONAL TEST

After conducting the tests above, and reconnecting the Network Isolator into the Ethernet network, it is recommended to check whether the signal transmission is still performing correctly. Such a functional test can be performed, for example, with a suitable Ethernet cable certification device. See also Section *8.1 FUNCTION AND COMPLIANCE TESTS*.

9 SPECIFICATIONS

9.1 GENERAL

Category	Standards or Test Criteria	Properties
Designation		EMOSAFE EN-50
Housing colour		Black
Housing Material		Plastic
Construction		Panel Mount
Mounting Arrangement		Screws
Input Interface		RJ45 Jack, straight
Output Interface		RJ45 Jack, straight (EN-50HG-S, EN-50HG-Y) RJ45 Jack, angled (EN-50VG-S)
Weight		approximately 35 g
Protection rating	EN 60529	IP20
Mating cycles: Correct:	RJ45 plug in RJ45 socket	> 1000 cycles
Mismatched:	with RJ11 / RJ12 / RJ25	maximum of 100 cycles
Mean Time To Failure (MTTF)	SN 29500 Standard Temperature: 25°C Duty cycle: 100% (24 hours, 7 days)	4,130 years
	SN 29500 Standard Temperature: 40°C Duty cycle: 100% (24 hours, 7 days)	3,710 years

9.2 ETHERNET PERFORMANCE

Category	Standards or Test Criteria	EN-50
Transmission Speeds and Supported Network Protocols	10 Mbit/s, 10Base-T (IEEE802.3 Cl.14)	✓
	100 Mbit/s, 100Base-Tx (IEEE802.3 Cl.25)	✓
	1000 Mbit/s, 1000Base-T (IEEE802.3 Cl.40)	✓ *
Performance Category	ISO 11801, Permanent Link (PL)	Class C
Insertion Loss (absolute)	Typical:	1.5 dB @ 100 MHz
	Maximum:	2.5 dB @ 100 MHz
Return Loss (absolute)	Typical:	8.0 dB @ 100 MHz
	Minimum:	6.0 dB @ 100 MHz

* Transmission speeds of 1 Gbit/s are generally easily achievable with high-quality cabling and modern Ethernet network cards. For standard-compliant signal paths at 1 Gbit/s, or for critical applications, we recommend utilising Network Isolators that satisfy the requirements of ISO 11801 Permanent Link Class D.

9.3 ELECTRICAL

Category	Standards or Test Criteria		EN-50
AC Dielectric Strength	at 50 Hz, for 60 seconds		4.0 kV
DC Dielectric Strength	for 60 seconds		5.6 kV
Reinforced Isolation	IEC 60601-1		✓
Coupling Capacitance per Channel			25 pF ±20%
Coupling Capacitance of Shield Capacitors	two 1 nF Y1 capacitors in series		500 pF ±20%
Total Coupling Capacitance			600 pF ±20%
Total resistance of shield resistors	two 33 MΩ high-voltage resistors in series		66 MΩ
Total Leakage Current	275 V AC at 50 Hz	Typical:	60.0 μA
		Maximum:	80.0 μA

9.4 OPERATING CONDITIONS AND AREA OF APPLICATION

Category	Standards or Test Criteria		EN-50
Pollution Degree	IEC 61010		2 *
Overvoltage Category	IEC 60664-1		III
Maximum Working Voltage †	Maximum mains voltage of the connected devices, in accordance with IEC 60601-1		250 V AC 300 V DC
Temperature		Minimum:	+1°C
		Maximum:	+70°C
Air Humidity	Non-condensing	Minimum:	10%
		Maximum:	90%
Air Pressure		Minimum:	700 hPa
		Maximum:	1,060 hPa
Altitude		Maximum:	3,200 m

9.5 ENVIRONMENTAL CONDITIONS: STORAGE AND TRANSPORTATION

Category	Standards or Test Criteria		EN-50
Temperature		Minimum:	-25°C
		Maximum:	+85°C
Air Humidity	Non-condensing	Minimum:	10%
		Maximum:	90%
Air Pressure		Minimum:	500 hPa
		Maximum:	1,060 hPa

* Normally only nonconductive pollution occurs. Temporary conductivity caused by condensation is to be expected.

† The Network Isolator can be permanently exposed to this voltage level.

9.6 CERTIFICATES

All Network Isolators from EMO Systems GmbH are additionally registered by UL International as Recognized Components, under the file numbers E249126 and E362969. They are therefore suitable for application in American and Canadian markets.

Furthermore, the compliance of our Network Isolators with the standard specifications IEC 60601-1 (3rd Ed.), ANSI/AAMI ES60601-1 and CAN/CSA-C22.2 No. 60601-1 has been confirmed by an independent, accredited laboratory. To view a copy of these certificates, please visit the [UL Online Directory](#) or contact us directly.

The certification of our products to the requirements of the IEC 60601-1-2 has also been confirmed by an external laboratory. The test report can be obtained upon request.

Our Declaration of Conformity can be found on our website, which confirms the compliance of our products with the requirements of the Low Voltage Directive, the Electromagnetic Compatibility Directive, and the Restriction of Hazardous Substances Directive (RoHS).

Category	Standards or Test Criteria	EN-50
UL Recognized Component		✓
UL File No.		E246126 E362969
IEC 60601-1	Complies with the requirements of a galvanic separator in accordance with IEC 60601-1 (Ed. 3.1)	✓
IEC 60601-1-2	Complies with the requirements of IEC 60601-1-2	✓
ANSI/AAMI ES 60601-1	Complies with the requirements of ANSI/AAMI ES60601-1	✓
CAN/CSA-C22.2 No. 60601-1	Complies with the requirements of CAN/CSA-C22.2 No. 60601-1	✓
Low Voltage Directive	Complies with the requirements of the directive 2014/35/EU	✓
EMC Directive	Complies with the requirements of the directive 2004/108/EU	✓
RoHS Directive	Complies with the requirements of the directive 2011/65/EU	✓
Lead-free	Contains no lead-containing substances, and is manufactured with lead-free solder	✓

9.7 ISOLATION DIAGRAM

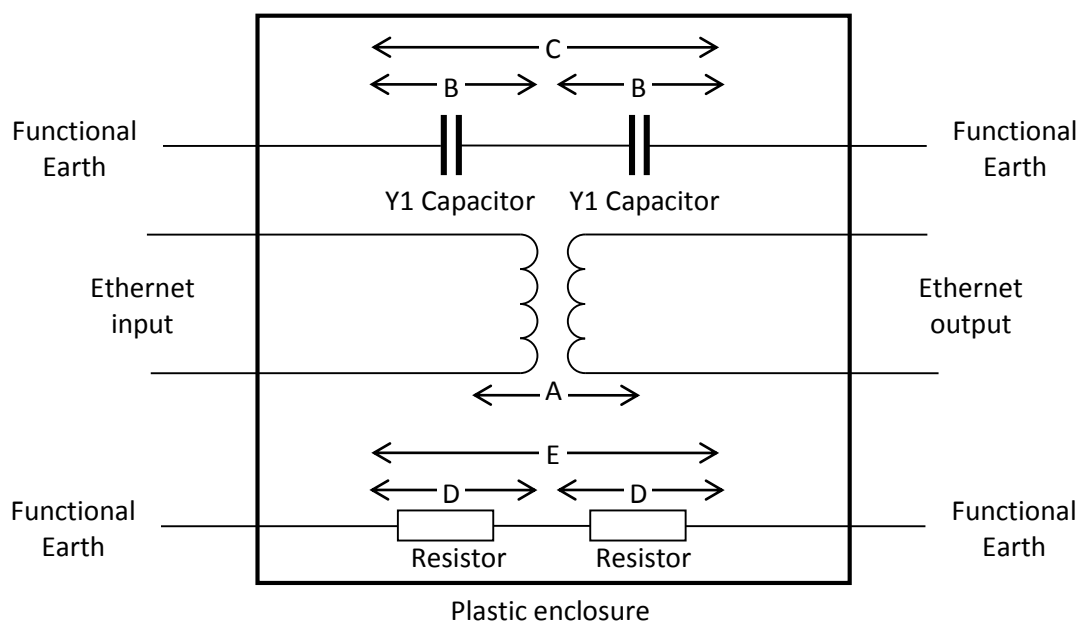

Figure 12. Isolation diagram for all EN-50 models

Area	Number and type of Means of Protection	Material Group (from CTI)	Maximum Operating Voltage		Required creepage distance (mm)	Required clearance distance (mm)	Measured creepage distance (mm)	Measured clearance distance (mm)
			V AC	V _{peak}				
A	2 MOPP *	IIIb †	250	353	8.0	5.0	11.5	11.5
B	1 MOPP *	IIIb †	250	353	4.0	2.5	7.6	7.6
C	2 MOPP *	IIIb †	250	353	8.0	5.0	16.3	16.3
D	1 MOPP *	IIIb †	250	353	4.0	2.5	5.7	5.7
E	2 MOPP *	IIIb †	250	353	8.0	5.0	13.2	13.2

* MOPP = Means of Patient Protection

† Materials in the Material Group IIIb have a Comparative Tracking Index (CTI) value between 100 and 175.

9.8 FREQUENCY RESPONSE

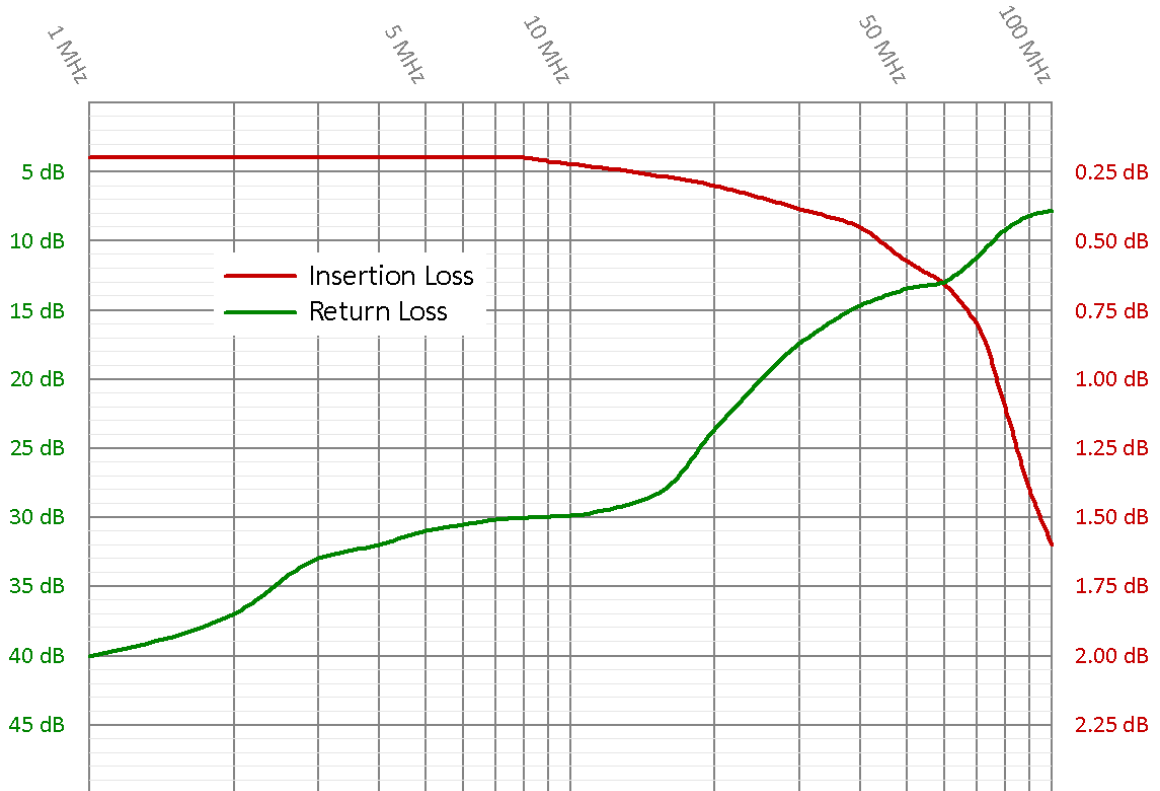

Figure 13. Typical frequency response for Insertion Loss and Return Loss of an EMOSAFE EN-50 Network Isolator.

10 CIRCUIT DIAGRAMS

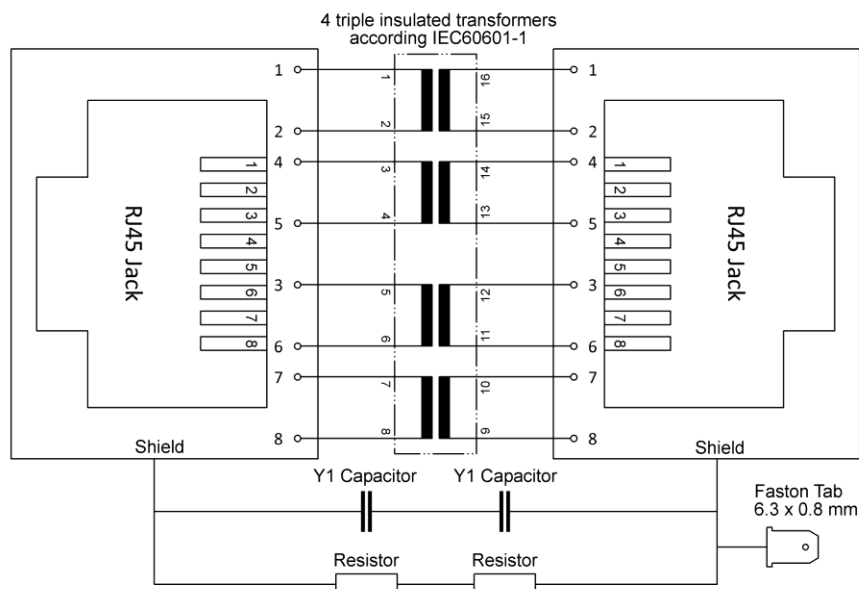

Figure 14. Circuit diagram for EN-50HG-S, EN-50VG-S, and EN-50HG-Y

11 PACKAGING





Contents:

- Network Isolator. One of: EN-50HG-S, EN-50VG-S, or EN-50HG-Y

A packaging label provides the following information:

- Article description
- Quantity
- Ordering code (OC)
- Date of Manufacture
- Serial number
- The serial number is printed as both a 1D- (Code 128) and a 2D barcode (Data Matrix).

12 PRODUCT MARKINGS

	<p>Through this mark, the conformity of the product with all applicable EU Directives is confirmed.</p>
	<p>Designates the product as a UL "Recognised Component"; File number E249126.</p>
	<p>The product may not be disposed of in domestic rubbish.</p>
	<p>This product contains no substances containing lead and is manufactured using lead-free solder.</p>
	<p>This product meets the requirements of EU Directive concerning the limitation of the use of certain hazardous substances in electric and electronic equipment.</p>

13 SCHEDULED MAINTENANCE

When used as directed, EMOSAFE Network Isolators are maintenance-free.

14 ENVIRONMENTAL PROTECTION INFORMATION

This device contains electronic components. At the end of its service life it is to be returned to the manufacturer for disposal.

15 QUALITY

EMO Systems operates a certified quality management system for development and production in accordance with ISO 9001 and ISO 13485. Prior to delivery, each Network Isolator is subjected to a comprehensive quality inspection. This inspection ensures, among other factors, that the attained values for leakage currents, dielectric withstand strengths, insertion losses, return losses, and near end crosstalk values all meet the specified requirements.

16 CONTACT AND SUPPORT

Please find our up-to-date contact details on our website: <http://www.emosystems.de/en/contact>

Or send us an e-mail at the following address: support@emosystems.de

17 LEGAL NOTIFICATION

The information provided above in this datasheet has been compiled with all due care, and is believed to be accurate and reliable. However, we cannot guarantee that the information contained is completely free from error.

The end user is responsible and liable for the proper use of this product; EMO Systems assume no liability. We reserve the right to make changes to this datasheet without notice.



Компания «ЭлектроПласт» предлагает заключение долгосрочных отношений при поставках импортных электронных компонентов на взаимовыгодных условиях!

Наши преимущества:

- Оперативные поставки широкого спектра электронных компонентов отечественного и импортного производства напрямую от производителей и с крупнейших мировых складов;
- Поставка более 17-ти миллионов наименований электронных компонентов;
- Поставка сложных, дефицитных, либо снятых с производства позиций;
- Оперативные сроки поставки под заказ (от 5 рабочих дней);
- Экспресс доставка в любую точку России;
- Техническая поддержка проекта, помощь в подборе аналогов, поставка прототипов;
- Система менеджмента качества сертифицирована по Международному стандарту ISO 9001;
- Лицензия ФСБ на осуществление работ с использованием сведений, составляющих государственную тайну;
- Поставка специализированных компонентов (Xilinx, Altera, Analog Devices, Intersil, Interpoint, Microsemi, Aeroflex, Peregrine, Syfer, Eurofarad, Texas Instrument, Miteq, Cobham, E2V, MA-COM, Hittite, Mini-Circuits, General Dynamics и др.);

Помимо этого, одним из направлений компании «ЭлектроПласт» является направление «Источники питания». Мы предлагаем Вам помощь Конструкторского отдела:

- Подбор оптимального решения, техническое обоснование при выборе компонента;
- Подбор аналогов;
- Консультации по применению компонента;
- Поставка образцов и прототипов;
- Техническая поддержка проекта;
- Защита от снятия компонента с производства.



Как с нами связаться

Телефон: 8 (812) 309 58 32 (многоканальный)

Факс: 8 (812) 320-02-42

Электронная почта: org@eplast1.ru

Адрес: 198099, г. Санкт-Петербург, ул. Калинина, дом 2, корпус 4, литера А.