

### General Description

Micrel's MIC4826 is a high output voltage, DC to AC converter, designed for driving EL (Electroluminescent) lamps. The device operates from an input voltage range of 1.8V to 5.5V, making it suitable for 1-cell Li Ion and 2- or 3-cell alkaline/NiCad/NiMH battery applications. The MIC4826 converts a low voltage DC input to a 160V<sub>PP</sub> AC output signal that drives the EL lamp.

The MIC4826 is comprised of two stages: a boost stage, and an H-bridge, lamp driver, stage. The boost stage steps the input voltage up to +80V. The H-bridge stage then alternately switches the +80V output to each terminal of the EL lamp, thus creating a 160V<sub>PP</sub> AC signal to drive the EL lamp and generate light.

The MIC4826 features separate oscillators for the boost- and H-bridge stages. External resistors independently set the operating frequency of each stage. This flexibility allows the EL lamp circuit to be optimized for maximum efficiency and brightness.

The MIC4826 uses a single inductor and a minimum number of external components, making it ideal for portable, space-sensitive applications.

The MIC4826 is available in an 8-pin MSOP package with an ambient temperature range of -40°C to +85°C.

### Features

- 1.8V to 5.5V DC input voltage
- 160V<sub>PP</sub> regulated AC output waveform
- Independently adjustable EL lamp frequency
- Independently adjustable boost converter frequency
- 0.1µA shutdown current

### Applications

- LCD panel backlight
- Cellular phones
- PDAs
- Pagers
- Calculators
- Remote controls
- Portable phones

### Ordering Information

Part Number		Temp. Range	Package
Standard	Pb-Free		
MIC4826BMM	MIC4826YMM	-40°C to +85°C	MSOP-8

### Typical Application

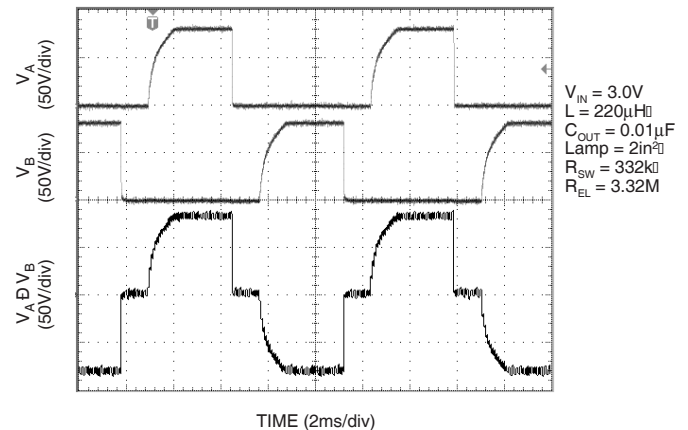
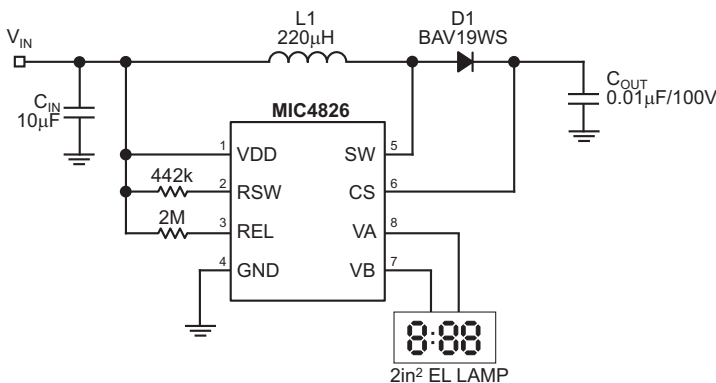

High Voltage EL Driver

## Pin Configuration

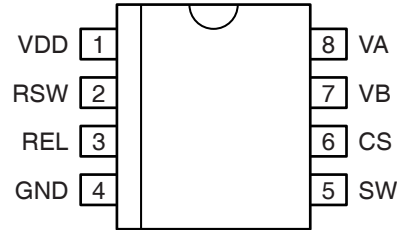

**8-Pin MSOP Package (MM)**

## Pin Description

Pin Number	Pin Name	Pin Function
1	VDD	Supply (Input): 1.8V to 5.5V for internal circuitry.
2	RSW	Switch Resistor (External Component): Set switch frequency of the internal power MOSFET by connecting an external resistor to VDD. Connecting the external resistor to GND disables the switch oscillator and shutdown the device.
3	REL	EL Resistor (External Component): Set EL frequency of the internal H-bridge driver by connecting an external resistor to VDD. Connecting the external resistor to GND disables the EL oscillator.
4	GND	Ground Return.
5	SW	Switch Node (Input): Internal high-voltage power MOSFET drain.
6	CS	Regulated Boost Output (External Component): Connect to the output capacitor of the boost regulator and connect to the cathode of the diode.
7	VB	EL Output: Connect to one end of the EL lamp. Polarity is not important.
8	VA	EL Output: Connect to the other end of the EL lamp. Polarity is not important.

**Absolute Maximum Rating (Note 1)**

Supply Voltage ( $V_{DD}$ )	-0.5V to +6V
Output Voltage ( $V_{CS}$ )	-0.5V to +100V
Frequency Control Voltage ( $V_{RSW}$ , $V_{REL}$ )	-0.5V to ( $V_{DD} + 0.3V$ )
Power Dissipation @ $T_A = 85^\circ\text{C}$	200mW
Storage Temperature ( $T_S$ )	-65°C to +150°C
ESD Rating	<b>Note 3</b>

**Operating Ratings (Note 2)**

Supply Voltage ( $V_{DD}$ )	1.8V to 5.5V
Lamp Drive Frequency ( $f_{EL}$ )	60Hz to 1000Hz
Switching Transistor Frequency ( $f_{SW}$ )	8kHz to 200kHz
Ambient Temperature ( $T_A$ )	-40°C to +85°C
Package Thermal Resistance 8-pin MSOP ( $\theta_{JA}$ )	206°C/W

**Electrical Characteristics**

$V_{IN} = V_{DD} = 3.0V$ ,  $R_{SW} = 560K\Omega$ ,  $R_{EL} = 1.0M\Omega$ .  $T_A = 25^\circ\text{C}$  unless otherwise specified. **Bold** values indicate  $-40^\circ\text{C} \leq T_A \leq +85^\circ\text{C}$

Symbol	Parameter	Condition	Min	Typ	Max	Units
$R_{DS(ON)}$	On-resistance of switching transistor	$I_{SW} = 100\text{ mA}$ , $V_{CS} = 75V$		3.8	<b>7.0</b>	$\Omega$
$V_{CS}$	Output voltage regulation	$V_{DD} = 1.8V$ to $5.5V$	75	80	85	V
			<b>73</b>		<b>87</b>	V
$V_A - V_B$	Output peak-to-peak voltage	$V_{DD} = 1.8V$ to $5.5V$	150	160	170	V
			<b>146</b>		<b>174</b>	V
$V_{EN-L}$	Input low voltage (turn off)	$V_{DD} = 1.8V$ to $5.5V$			0.5	V
$V_{EN-H}$	Input high voltage (turn on)	$V_{DD} = 1.8V$ to $5.5V$	$V_{DD} - 0.5$			V
$I_{SD}$	Shutdown current, <b>Note 4</b>	$R_{SW} = \text{LOW}$ ; $R_{EL} = \text{LOW}$ ; $V_{DD} = 5.5V$		0.01	0.1	$\mu\text{A}$
					<b>0.5</b>	$\mu\text{A}$
$I_{VDD}$	Input supply current	$R_{SW} = \text{HIGH}$ ; $R_{EL} = \text{HIGH}$ ; $V_{CS} = 75V$ ; $V_A$ , $V_B$ OPEN		21	<b>75</b>	$\mu\text{A}$
$I_{CS}$	Boosted supply current	$R_{SW} = \text{HIGH}$ ; $R_{EL} = \text{HIGH}$ ; $V_{CS} = 75V$ ; $V_A$ , $V_B$ OPEN		200	<b>400</b>	$\mu\text{A}$
$I_{IN}$	Input current including inductor current	$V_{IN} = V_{DD} = 1.8V$ (See Test Circuit)		28		mA
$f_{EL}$	$V_A - V_B$ output drive frequency		285	360	435	Hz
$f_{SW}$	Switching transistor frequency		53	66	79	kHz
D	Switching transistor duty cycle			90		%

**Note 1.** Exceeding the absolute maximum rating may damage the device.

**Note 2.** The device is not guaranteed to function outside its operating rating.

**Note 3.** Devices are ESD sensitive. Handling precautions recommended.

**Note 4.** Shutdown current is defined as the sum of current going into pin 1, 5, and 6 when the device is disabled.

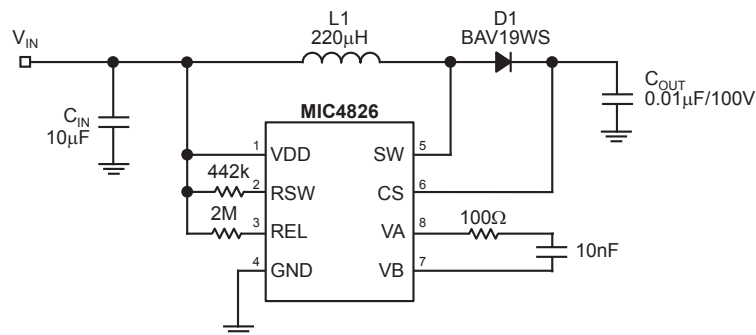
**Test Circuit**

# Typical Characteristics

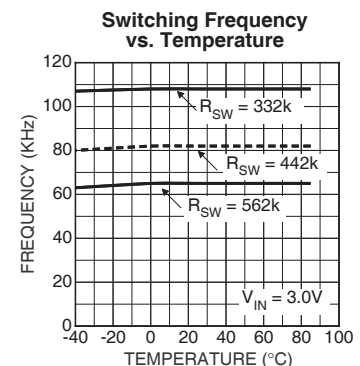
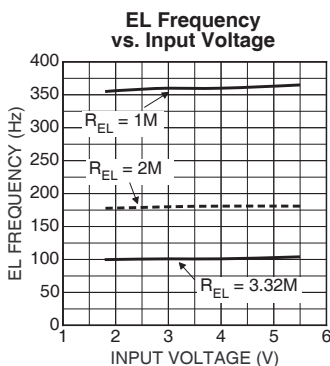
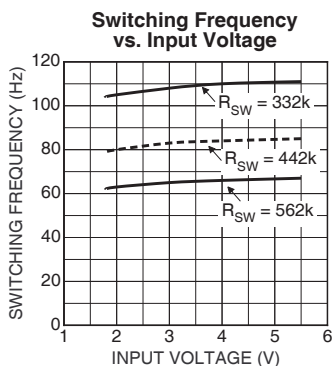
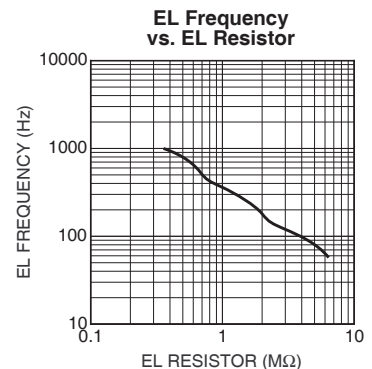
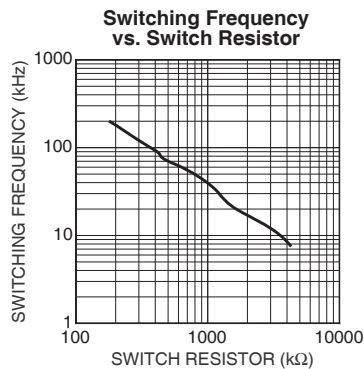
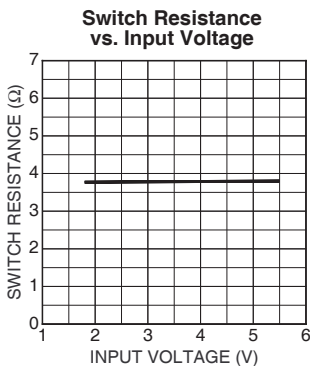
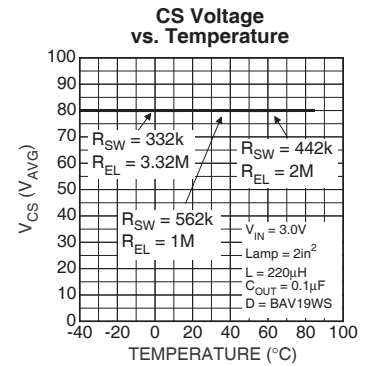
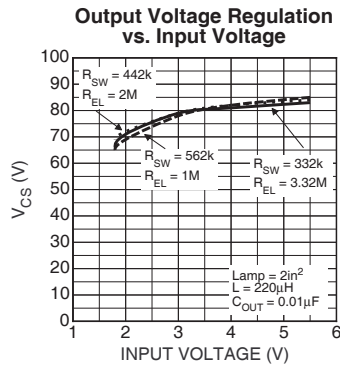
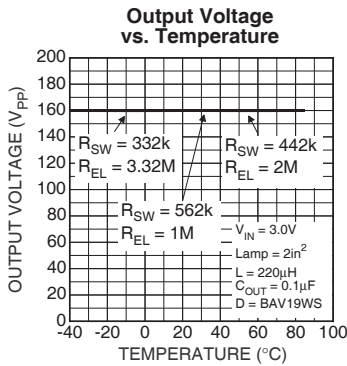
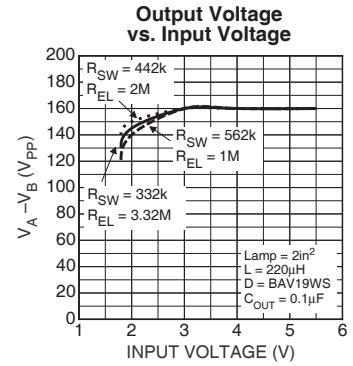
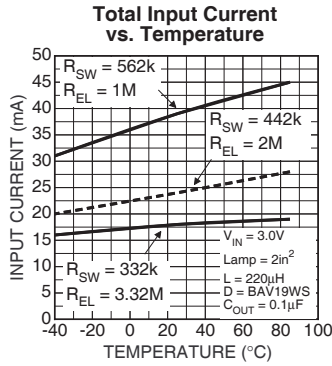
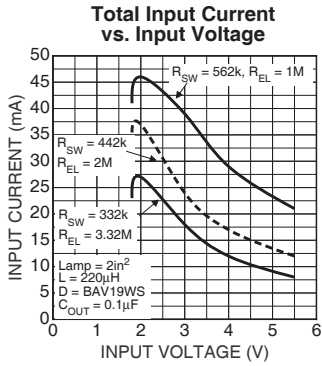

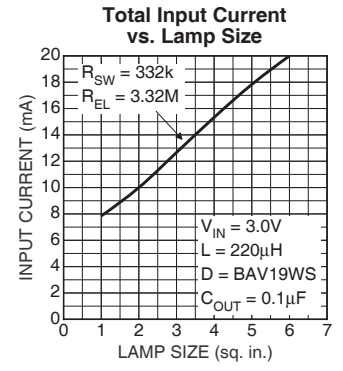
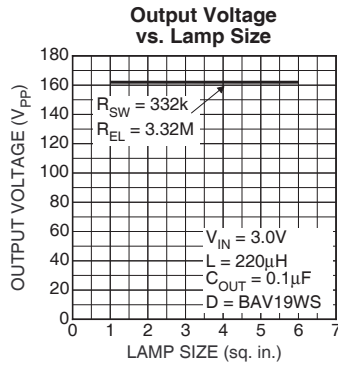
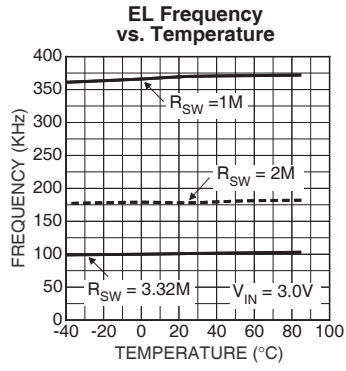

## Functional Diagram

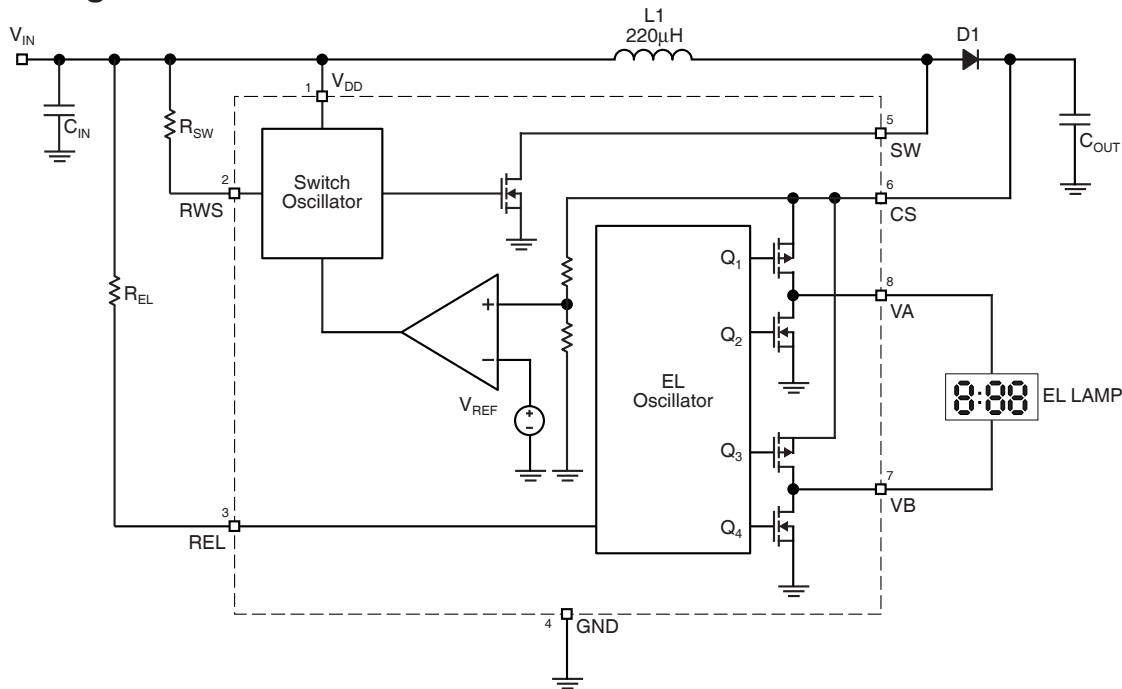

Figure 1. MIC4826 Block Diagram

## Functional Description

See "Application Information" for component selection and pre-designed circuits.

### Overview

The MIC4826 is a high voltage EL driver with an AC output voltage of 160V peak-to-peak capable of driving EL lamps up to 6 in<sup>2</sup>. Input supply current for the MIC4826 is typically 21µA with a typical shutdown current of 10nA. The high voltage EL driver has two internal oscillators to control the switching MOSFET and the H-bridge driver. Both of the internal oscillators' frequencies can be individually programmed through the external resistors to maximize the efficiency and the brightness of the lamps.

### Regulation

Referring to Figure 1, initially power is applied to V<sub>DD</sub>. The internal feedback voltage is less than the reference voltage causing the internal comparator to go low which enables the switching MOSFET's oscillator. When the switching MOSFET turns on, current flows through the inductor and into the switch. The switching MOSFET will typically turn on for 90% of the switching frequency. During the on-time, energy is stored in the inductor. When the switching MOSFET turns off, current flowing into the inductor forces the voltage across the inductor to reverse polarity. The voltage across the inductor rises until the external diode conducts and clamps the voltage at V<sub>OUT</sub>+V<sub>D1</sub>. The energy in the inductor is then discharged into the C<sub>OUT</sub> capacitor. The internal comparator continues to turn the switching MOSFET on and off until the internal feedback voltage is above the reference voltage. Once the internal feedback voltage is above the reference voltage, the internal comparator turns off the switching MOSFET's oscillator.

When the EL oscillator is enabled, V<sub>A</sub> and V<sub>B</sub> switch in opposite states to achieve a 160V peak-to-peak AC output signal. The external resistor that connects to the REL pin determines the EL frequency.

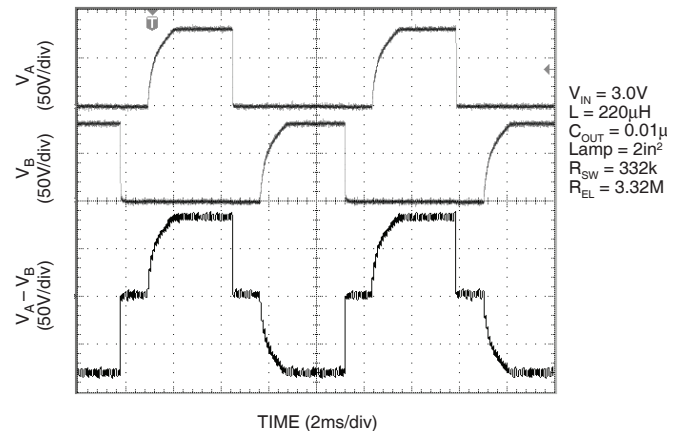

Figure 2. 108Hz Typical Output Waveform

### Switching Frequency

The switching frequency of the converter is controlled via an external resistor between R<sub>SW</sub> pin and V<sub>DD</sub> pin of the device. The switching frequency increases as the resistor value decreases. For resistor value selections, see "Typical Characteristics: Switching Frequency vs. Switch Resistor" or use the equation below. The switching frequency range is 8kHz to 200kHz, with an accuracy of ±20%.

$$f_{sw}(\text{kHz}) = \frac{36}{R_{sw}(\text{M}\Omega)}$$

**EL Frequency**

The EL lamp frequency is controlled via an external resistor connected between REL pin and VDD pin of the device. As the lamp frequency increases, the resistor value decreases. For resistor value selections, see the “Typical Characteristics: EL Frequency vs. EL Resistor” or use the equation below. The EL frequency range is 60Hz to 1000Hz, with an accuracy of ±20%.

$$f_{EL} \text{ (Hz)} = \frac{360}{R_{EL} \text{ (M}\Omega\text{)}}$$

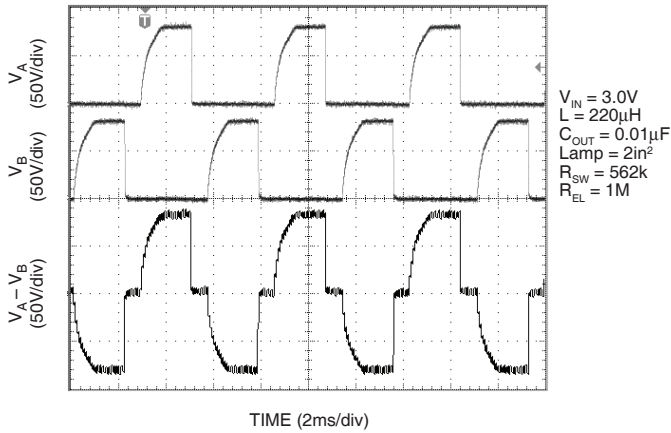

**Figure 3. 180Hz Output Waveform**

In general, as the EL lamp frequency increases, the amount of current drawn from the battery will increase. The color of the EL lamp and the intensity are dependent upon its frequency.

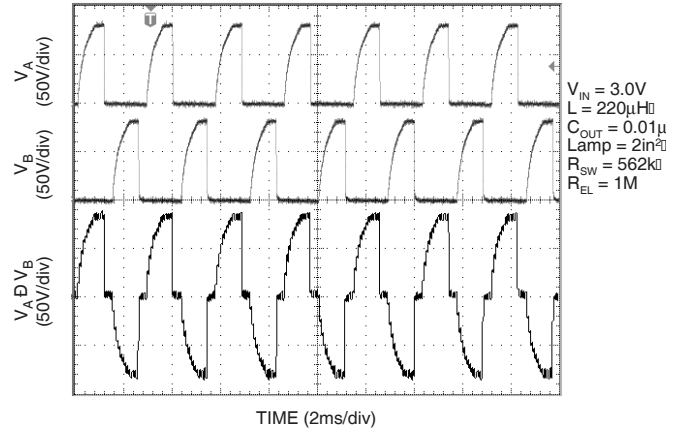

**Figure 4. 360Hz Output Waveform**

**Enable Function**

The enable function of the MIC4826 is implemented by switching the R<sub>SW</sub> and R<sub>EL</sub> resistor between ground and V<sub>DD</sub>. When R<sub>SW</sub> and R<sub>EL</sub> are connected to ground, the switch and the EL oscillators are disabled; therefore the EL driver becomes disabled. When these resistors connect to V<sub>DD</sub>, both oscilla-

tors will function and the EL driver is enabled.

## Application Information

### Inductor

In general, smaller value inductors, which can handle more current, are more suitable to drive larger size lamps. As the inductor value decreases, the switching frequency (controlled by  $R_{SW}$ ) should be increased to avoid saturation or the input voltage should be increased. Typically, inductor values ranging from  $220\mu\text{H}$  to  $560\mu\text{H}$  can be used. Murata offers the LQH3C series up to  $560\mu\text{H}$  and LQH4C series up to  $470\mu\text{H}$ , with low DC resistance. A  $220\mu\text{H}$  Murata (LQH4C221K04) inductor is recommended for driving a lamp size of 3 square inches. It

has a maximum DC resistance of  $4.0\Omega$ .

### Diode

The diode must have a high reverse voltage (100V) since the output voltage at the CS pin can reach up to 100V. A fast switching diode with lower forward voltage and higher reverse voltage (100V), such as BAV19WS, can be used to enhance efficiency.

### Output Capacitor

Low ESR capacitors should be used at the regulated boost output (CS pin) of the MIC4826 to minimize the switching output ripple voltage. Selection of the capacitor value will depend upon the peak inductor current, inductor size, and the load. MuRata offers the GRM40 series with up to  $0.015\mu\text{F}$  at 100V, with a X7R temperature coefficient in 0805 surface-mount package. Typically, values ranging from  $0.01\mu\text{F}$  to  $0.1\mu\text{F}$  at 100V can be used for the regulated boost output capacitor.

## Pre-designed Application Circuits

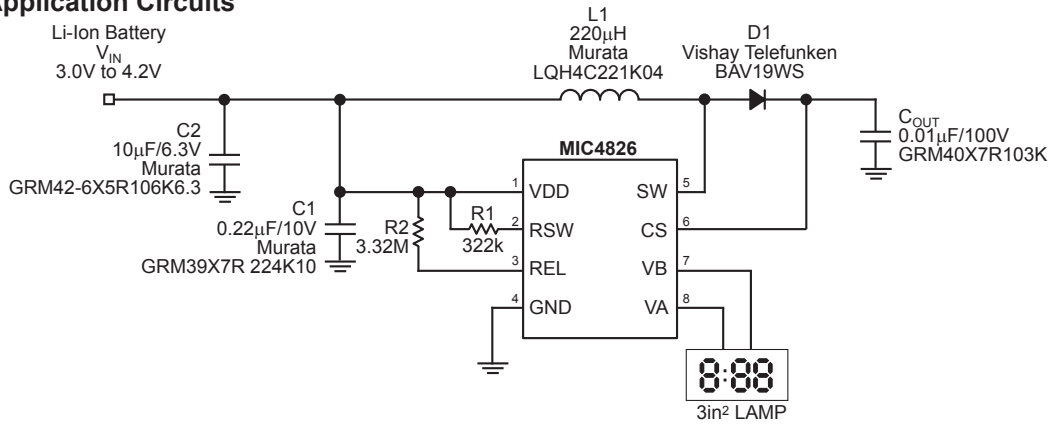

$V_{IN}$	$I_{IN}$	$V_A - V_B$	$F_{EL}$	Lamp Size
3.3V	20mA	$160V_{PP}$	100Hz	$3\text{in}^2$

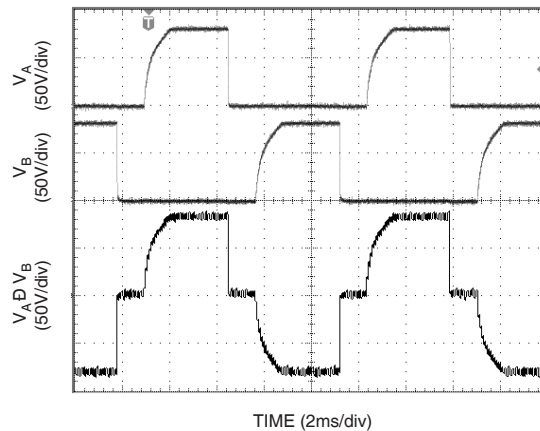
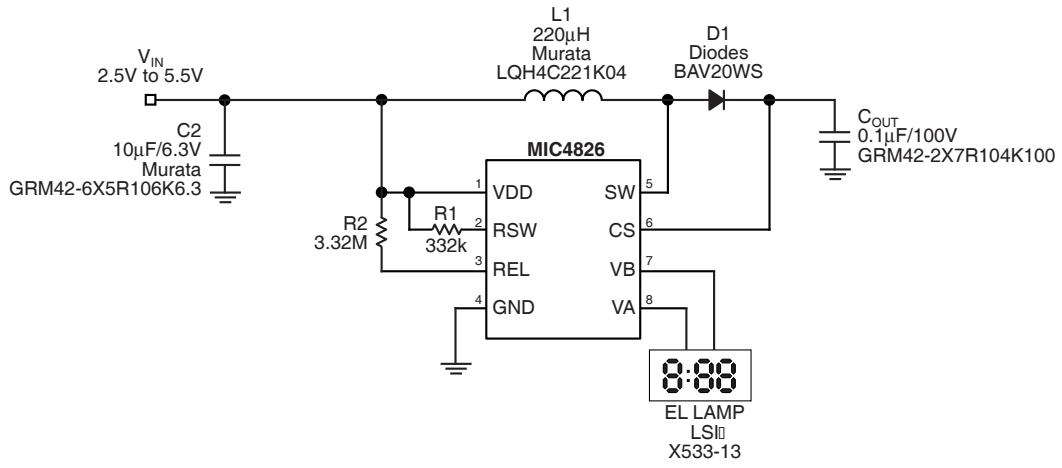

Figure 5. Typical 100Hz EL Driver for  $3\text{in}^2$  Lamp





$V_{IN}$	$I_{IN}$	$V_A - V_B$	$F_{EL}$	Lamp Size
3.3V	14mA	160V <sub>PP</sub>	100Hz	2in <sup>2</sup>

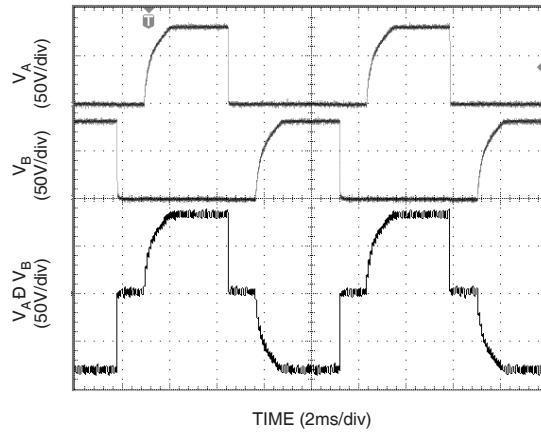
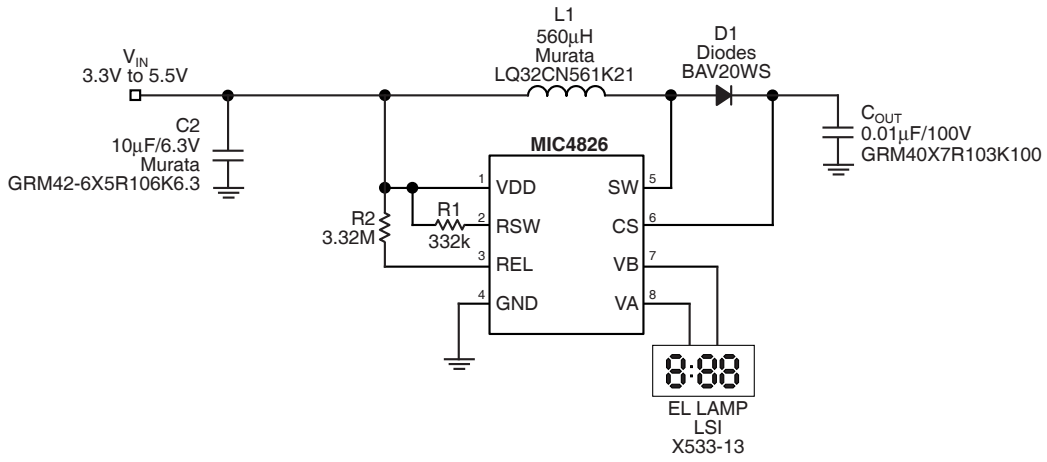

Figure 6. Typical EL Driver for 2in<sup>2</sup> Lamp with  $C_S = 0.1\mu F$



$V_{IN}$	$I_{IN}$	$V_A - V_B$	$F_{EL}$	Lamp Size
3.3V	13.2mA	160V <sub>PP</sub>	100Hz	2in <sup>2</sup>

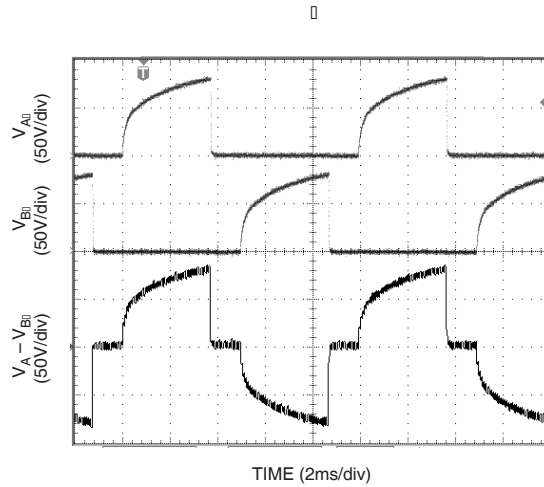
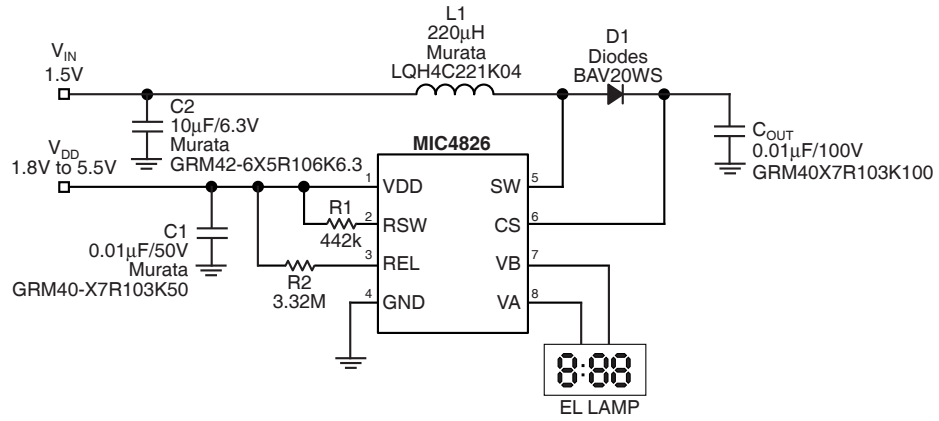

Figure 7. Typical EL Driver for 2in<sup>2</sup> Lamp with 560µH inductor



$V_{IN}$	$I_{IN}$	$V_{DD}$	$I_{DD}$	$V_A - V_B$	$F_{EL}$	Lamp Size
1.5V	22mA	3.0V	36µA	160V <sub>PP</sub>	100Hz	1.6in <sup>2</sup>

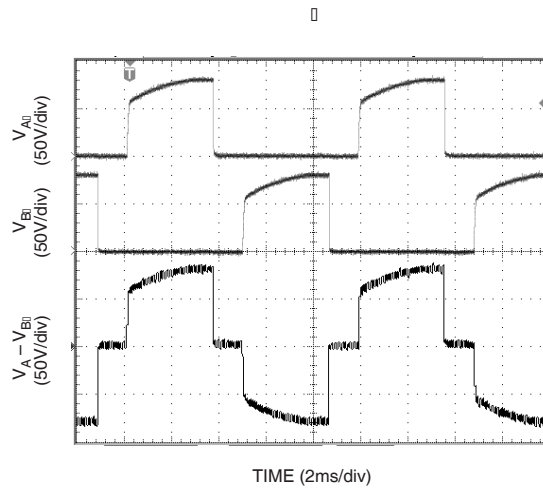
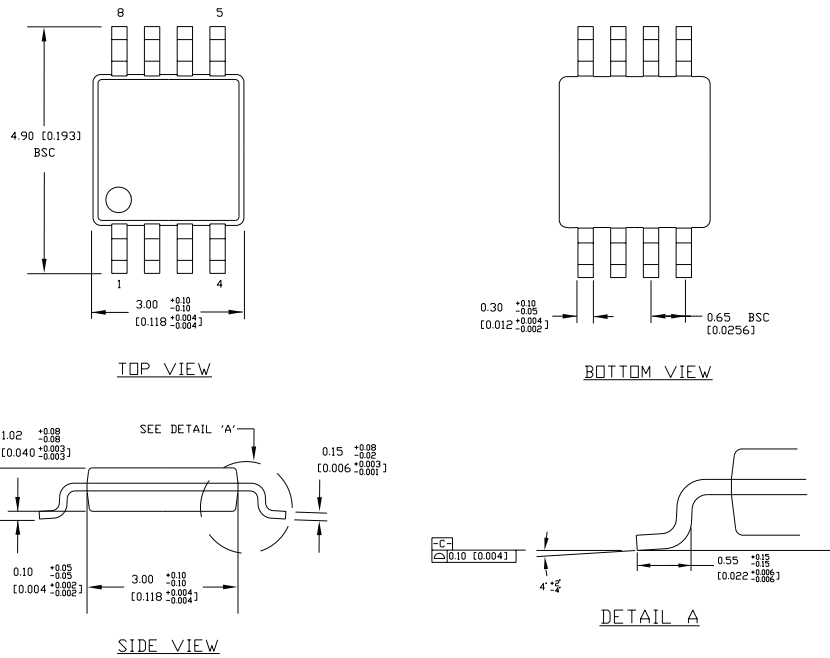

Figure 8. Typical Split Power Supplies Applications

## Package Information



- NOTES:
1. DIMENSIONS ARE IN MM [INCHES].
  2. CONTROLLING DIMENSION: MM
  3. DIMENSION DOES NOT INCLUDE MOLD FLASH OR PROTRUSIONS, EITHER OF WHICH SHALL NOT EXCEED 0.20 [0.008] PER SIDE.

### 8-Lead MSOP (MM)

**MICREL INC. 2180 FORTUNE DRIVE SAN JOSE, CA 95131 USA**

TEL + 1 (408) 944-0800 FAX + 1 (408) 474-1000 WEB <http://www.micrel.com>

The information furnished by Micrel in this data sheet is believed to be accurate and reliable. However, no responsibility is assumed by Micrel for its use. Micrel reserves the right to change circuitry and specifications at any time without notification to the customer.

Micrel Products are not designed or authorized for use as components in life support appliances, devices or systems where malfunction of a product can reasonably be expected to result in personal injury. Life support devices or systems are devices or systems that (a) are intended for surgical implant into the body or (b) support or sustain life, and whose failure to perform can be reasonably expected to result in a significant injury to the user. A Purchaser's use or sale of Micrel Products for use in life support appliances, devices or systems is a Purchaser's own risk and Purchaser agrees to fully indemnify Micrel for any damages resulting from such use or sale.

© 2001 Micrel Incorporated



Компания «ЭлектроПласт» предлагает заключение долгосрочных отношений при поставках импортных электронных компонентов на взаимовыгодных условиях!

Наши преимущества:

- Оперативные поставки широкого спектра электронных компонентов отечественного и импортного производства напрямую от производителей и с крупнейших мировых складов;
- Поставка более 17-ти миллионов наименований электронных компонентов;
- Поставка сложных, дефицитных, либо снятых с производства позиций;
- Оперативные сроки поставки под заказ (от 5 рабочих дней);
- Экспресс доставка в любую точку России;
- Техническая поддержка проекта, помощь в подборе аналогов, поставка прототипов;
- Система менеджмента качества сертифицирована по Международному стандарту ISO 9001;
- Лицензия ФСБ на осуществление работ с использованием сведений, составляющих государственную тайну;
- Поставка специализированных компонентов (Xilinx, Altera, Analog Devices, Intersil, Interpoint, Microsemi, Aeroflex, Peregrine, Syfer, Eurofarad, Texas Instrument, Miteq, Cobham, E2V, MA-COM, Hittite, Mini-Circuits, General Dynamics и др.);

Помимо этого, одним из направлений компании «ЭлектроПласт» является направление «Источники питания». Мы предлагаем Вам помощь Конструкторского отдела:

- Подбор оптимального решения, техническое обоснование при выборе компонента;
- Подбор аналогов;
- Консультации по применению компонента;
- Поставка образцов и прототипов;
- Техническая поддержка проекта;
- Защита от снятия компонента с производства.



#### Как с нами связаться

**Телефон:** 8 (812) 309 58 32 (многоканальный)

**Факс:** 8 (812) 320-02-42

**Электронная почта:** [org@eplast1.ru](mailto:org@eplast1.ru)

**Адрес:** 198099, г. Санкт-Петербург, ул. Калинина, дом 2, корпус 4, литера А.