

# MC68336/376

## USER'S MANUAL

TouCAN is a trademark of Motorola, Inc.

Motorola reserves the right to make changes without further notice to any products herein. Motorola makes no warranty, representation or guarantee regarding the suitability of its products for any particular purpose, nor does Motorola assume any liability arising out of the application or use of any product or circuit, and specifically disclaims any and all liability, including without limitation consequential or incidental damages. "Typical" parameters can and do vary in different applications. All operating parameters, including "Typicals" must be validated for each customer application by customer's technical experts. Motorola does not convey any license under its patent rights nor the rights of others. Motorola products are not designed, intended, or authorized for use as components in systems intended for surgical implant into the body, or other applications intended to support or sustain life, or for any other application in which the failure of the Motorola product could create a situation where personal injury or death may occur. Should Buyer purchase or use Motorola products for any such unintended or unauthorized application, Buyer shall indemnify and hold Motorola and its officers, employees, subsidiaries, affiliates, and distributors harmless against all claims, costs, damages, and expenses, and reasonable attorney fees arising out of, directly or indirectly, any claim of personal injury or death associated with such unintended or unauthorized use, even if such claim alleges that Motorola was negligent regarding the design or manufacture of the part. MOTOROLA and ! are registered trademarks of Motorola, Inc. Motorola, Inc. is an Equal Opportunity/Affirmative Action Employer.

© MOTOROLA, INC. 1996



# TABLE OF CONTENTS

Paragraph	Title	Page
-----------	-------	------

## SECTION 1 INTRODUCTION

## SECTION 2 NOMENCLATURE

2.1	Symbols and Operators .....	2-1
2.2	CPU32 Registers .....	2-2
2.3	Pin and Signal Mnemonics .....	2-2
2.4	Register Mnemonics .....	2-4
2.5	Conventions .....	2-8

## SECTION 3 OVERVIEW

3.1	MCU Features .....	3-1
3.1.1	Central Processing Unit (CPU32) .....	3-1
3.1.2	System Integration Module (SIM) .....	3-1
3.1.3	Standby RAM Module (SRAM) .....	3-1
3.1.4	Masked ROM Module (MRM) .....	3-1
3.1.5	10-Bit Queued Analog-to-Digital Converter (QADC) .....	3-2
3.1.6	Queued Serial Module (QSM) .....	3-2
3.1.7	Configurable Timer Module Version 4 (CTM4) .....	3-2
3.1.8	Time Processor Unit (TPU) .....	3-2
3.1.9	Static RAM Module with TPU Emulation Capability (TPURAM) .....	3-2
3.1.10	CAN 2.0B Controller Module (TouCAN) .....	3-3
3.2	Intermodule Bus .....	3-3
3.3	System Block Diagram and Pin Assignment Diagrams .....	3-3
3.4	Pin Descriptions .....	3-6
3.5	Signal Descriptions .....	3-9
3.6	Internal Register Map .....	3-13
3.7	Address Space Maps .....	3-14

## SECTION 4 CENTRAL PROCESSOR UNIT

4.1	General .....	4-1
4.2	CPU32 Registers .....	4-2
4.2.1	Data Registers .....	4-4
4.2.2	Address Registers .....	4-5
4.2.3	Program Counter .....	4-6
4.2.4	Control Registers .....	4-6
4.2.4.1	Status Register .....	4-6
4.2.4.2	Alternate Function Code Registers .....	4-7
4.2.5	Vector Base Register (VBR) .....	4-7
4.3	Memory Organization .....	4-7

## TABLE OF CONTENTS (Continued)

Paragraph	Title	Page
4.4	Virtual Memory .....	4-9
4.5	Addressing Modes .....	4-9
4.6	Processing States .....	4-9
4.7	Privilege Levels .....	4-10
4.8	Instructions .....	4-10
4.8.1	M68000 Family Compatibility .....	4-14
4.8.2	Special Control Instructions .....	4-14
4.8.2.1	Low-Power Stop (LPSTOP) .....	4-14
4.8.2.2	Table Lookup and Interpolate (TBL) .....	4-14
4.8.2.3	Loop Mode Instruction Execution .....	4-15
4.9	Exception Processing .....	4-15
4.9.1	Exception Vectors .....	4-15
4.9.2	Types of Exceptions .....	4-17
4.9.3	Exception Processing Sequence .....	4-17
4.10	Development Support .....	4-17
4.10.1	M68000 Family Development Support .....	4-18
4.10.2	Background Debug Mode .....	4-18
4.10.3	Enabling BDM .....	4-19
4.10.4	BDM Sources .....	4-19
4.10.4.1	External BKPT Signal .....	4-20
4.10.4.2	BGND Instruction .....	4-20
4.10.4.3	Double Bus Fault .....	4-20
4.10.4.4	Peripheral Breakpoints .....	4-20
4.10.5	Entering BDM .....	4-20
4.10.6	BDM Commands .....	4-21
4.10.7	Background Mode Registers .....	4-22
4.10.7.1	Fault Address Register (FAR) .....	4-22
4.10.7.2	Return Program Counter (RPC) .....	4-22
4.10.7.3	Current Instruction Program Counter (PCC) .....	4-23
4.10.8	Returning from BDM .....	4-23
4.10.9	Serial Interface .....	4-23
4.10.10	Recommended BDM Connection .....	4-25
4.10.11	Deterministic Opcode Tracking .....	4-26
4.10.12	On-Chip Breakpoint Hardware .....	4-26

### SECTION 5 SYSTEM INTEGRATION MODULE

5.1	General .....	5-1
5.2	System Configuration .....	5-2
5.2.1	Module Mapping .....	5-2
5.2.2	Interrupt Arbitration .....	5-2
5.2.3	Show Internal Cycles .....	5-3

## TABLE OF CONTENTS (Continued)

Paragraph	Title	Page
5.2.4	Register Access .....	5-3
5.2.5	Freeze Operation .....	5-3
5.3	System Clock .....	5-4
5.3.1	Clock Sources .....	5-4
5.3.2	Clock Synthesizer Operation .....	5-5
5.3.3	External Bus Clock .....	5-12
5.3.4	Low-Power Operation .....	5-12
5.4	System Protection .....	5-14
5.4.1	Reset Status .....	5-14
5.4.2	Bus Monitor .....	5-14
5.4.3	Halt Monitor .....	5-15
5.4.4	Spurious Interrupt Monitor .....	5-15
5.4.5	Software Watchdog .....	5-15
5.4.6	Periodic Interrupt Timer .....	5-17
5.4.7	Interrupt Priority and Vectoring .....	5-18
5.4.8	Low-Power STOP Mode Operation .....	5-19
5.5	External Bus Interface .....	5-19
5.5.1	Bus Control Signals .....	5-21
5.5.1.1	Address Bus .....	5-21
5.5.1.2	Address Strobe .....	5-21
5.5.1.3	Data Bus .....	5-21
5.5.1.4	Data Strobe .....	5-22
5.5.1.5	Read/Write Signal .....	5-22
5.5.1.6	Size Signals .....	5-22
5.5.1.7	Function Codes .....	5-22
5.5.1.8	Data and Size Acknowledge Signals .....	5-23
5.5.1.9	Bus Error Signal .....	5-23
5.5.1.10	Halt Signal .....	5-23
5.5.1.11	Autovector Signal .....	5-24
5.5.2	Dynamic Bus Sizing .....	5-24
5.5.3	Operand Alignment .....	5-25
5.5.4	Misaligned Operands .....	5-25
5.5.5	Operand Transfer Cases .....	5-26
5.6	Bus Operation .....	5-26
5.6.1	Synchronization to CLKOUT .....	5-26
5.6.2	Regular Bus Cycles .....	5-27
5.6.2.1	Read Cycle .....	5-28
5.6.2.2	Write Cycle .....	5-29
5.6.3	Fast Termination Cycles .....	5-30
5.6.4	CPU Space Cycles .....	5-30
5.6.4.1	Breakpoint Acknowledge Cycle .....	5-31

## TABLE OF CONTENTS (Continued)

Paragraph	Title	Page
5.6.4.2	LPSTOP Broadcast Cycle .....	5-34
5.6.5	Bus Exception Control Cycles .....	5-34
5.6.5.1	Bus Errors .....	5-36
5.6.5.2	Double Bus Faults .....	5-36
5.6.5.3	Retry Operation .....	5-37
5.6.5.4	Halt Operation .....	5-37
5.6.6	External Bus Arbitration .....	5-38
5.6.6.1	Show Cycles .....	5-39
5.7	Reset .....	5-40
5.7.1	Reset Exception Processing .....	5-40
5.7.2	Reset Control Logic .....	5-40
5.7.3	Reset Mode Selection .....	5-41
5.7.3.1	Data Bus Mode Selection .....	5-42
5.7.3.2	Clock Mode Selection .....	5-44
5.7.3.3	Breakpoint Mode Selection .....	5-45
5.7.4	MCU Module Pin Function During Reset .....	5-45
5.7.5	Pin States During Reset .....	5-46
5.7.5.1	Reset States of SIM Pins .....	5-46
5.7.5.2	Reset States of Pins Assigned to Other MCU Modules .....	5-47
5.7.6	Reset Timing .....	5-47
5.7.7	Power-On Reset .....	5-48
5.7.8	Use of the Three-State Control Pin .....	5-49
5.7.9	Reset Processing Summary .....	5-50
5.7.10	Reset Status Register .....	5-50
5.8	Interrupts .....	5-50
5.8.1	Interrupt Exception Processing .....	5-50
5.8.2	Interrupt Priority and Recognition .....	5-51
5.8.3	Interrupt Acknowledge and Arbitration .....	5-52
5.8.4	Interrupt Processing Summary .....	5-53
5.8.5	Interrupt Acknowledge Bus Cycles .....	5-54
5.9	Chip-Selects .....	5-54
5.9.1	Chip-Select Registers .....	5-57
5.9.1.1	Chip-Select Pin Assignment Registers .....	5-57
5.9.1.2	Chip-Select Base Address Registers .....	5-58
5.9.1.3	Chip-Select Option Registers .....	5-59
5.9.1.4	Port C Data Register .....	5-60
5.9.2	Chip-Select Operation .....	5-60
5.9.3	Using Chip-Select Signals for Interrupt Acknowledge .....	5-61
5.9.4	Chip-Select Reset Operation .....	5-62
5.10	Parallel Input/Output Ports .....	5-64
5.10.1	Pin Assignment Registers .....	5-64

## TABLE OF CONTENTS (Continued)

Paragraph	Title	Page
5.10.2	Data Direction Registers .....	5-64
5.10.3	Data Registers .....	5-64
5.11	Factory Test .....	5-64

### SECTION 6 STANDBY RAM MODULE

6.1	SRAM Register Block .....	6-1
6.2	SRAM Array Address Mapping .....	6-1
6.3	SRAM Array Address Space Type .....	6-1
6.4	Normal Access .....	6-2
6.5	Standby and Low-Power Stop Operation .....	6-2
6.6	Reset .....	6-3

### SECTION 7 MASKED ROM MODULE

7.1	MRM Register Block .....	7-1
7.2	MRM Array Address Mapping .....	7-1
7.3	MRM Array Address Space Type .....	7-2
7.4	Normal Access .....	7-2
7.5	Low-Power Stop Mode Operation .....	7-3
7.6	ROM Signature .....	7-3
7.7	Reset .....	7-3

### SECTION 8 QUEUED ANALOG-TO-DIGITAL CONVERTER MODULE

8.1	General .....	8-1
8.2	QADC Address Map .....	8-2
8.3	QADC Registers .....	8-2
8.4	QADC Pin Functions .....	8-2
8.4.1	Port A Pin Functions .....	8-3
8.4.1.1	Port A Analog Input Pins .....	8-4
8.4.1.2	Port A Digital Input/Output Pins .....	8-4
8.4.2	Port B Pin Functions .....	8-4
8.4.2.1	Port B Analog Input Pins .....	8-4
8.4.2.2	Port B Digital Input Pins .....	8-4
8.4.3	External Trigger Input Pins .....	8-5
8.4.4	Multiplexed Address Output Pins .....	8-5
8.4.5	Multiplexed Analog Input Pins .....	8-5
8.4.6	Voltage Reference Pins .....	8-5
8.4.7	Dedicated Analog Supply Pins .....	8-6
8.4.8	External Digital Supply Pin .....	8-6
8.4.9	Digital Supply Pins .....	8-6

## TABLE OF CONTENTS (Continued)

Paragraph	Title	Page
8.5	QADC Bus Interface .....	8-6
8.6	Module Configuration .....	8-6
8.6.1	Low-Power Stop Mode .....	8-6
8.6.2	Freeze Mode .....	8-7
8.6.3	Supervisor/Unrestricted Address Space .....	8-7
8.6.4	Interrupt Arbitration Priority .....	8-8
8.7	Test Register .....	8-8
8.8	General-Purpose I/O Port Operation .....	8-8
8.8.1	Port Data Register .....	8-9
8.8.2	Port Data Direction Register .....	8-9
8.9	External Multiplexing Operation .....	8-10
8.10	Analog Input Channels .....	8-12
8.11	Analog Subsystem .....	8-12
8.11.1	Conversion Cycle Times .....	8-13
8.11.1.1	Amplifier Bypass Mode Conversion Timing .....	8-14
8.11.2	Front-End Analog Multiplexer .....	8-15
8.11.3	Digital to Analog Converter Array .....	8-15
8.11.4	Comparator .....	8-16
8.11.5	Successive Approximation Register .....	8-16
8.12	Digital Control Subsystem .....	8-16
8.12.1	Queue Priority .....	8-16
8.12.2	Queue Boundary Conditions .....	8-19
8.12.3	Scan Modes .....	8-20
8.12.3.1	Disabled Mode and Reserved Mode .....	8-20
8.12.3.2	Single-Scan Modes .....	8-20
8.12.3.3	Continuous-Scan Modes .....	8-22
8.12.4	QADC Clock (QCLK) Generation .....	8-24
8.12.5	Periodic/Interval Timer .....	8-27
8.12.6	Control and Status Registers .....	8-28
8.12.6.1	Control Register 0 (QACR0) .....	8-28
8.12.6.2	Control Register 1 (QACR1) .....	8-28
8.12.6.3	Control Register 2 (QACR2) .....	8-28
8.12.6.4	Status Register (QASR) .....	8-28
8.12.7	Conversion Command Word Table .....	8-28
8.12.8	Result Word Table .....	8-31
8.13	Interrupts .....	8-32
8.13.1	Interrupt Sources .....	8-32
8.13.2	Interrupt Register .....	8-32
8.13.3	Interrupt Vectors .....	8-33
8.13.4	Initializing the QADC for Interrupt Driven Operation .....	8-34

## SECTION 9 QUEUED SERIAL MODULE



## TABLE OF CONTENTS (Continued)

Paragraph	Title	Page
9.1	General .....	9-1
9.2	QSM Registers and Address Map .....	9-2
9.2.1	QSM Global Registers .....	9-2
9.2.1.1	Low-Power Stop Operation .....	9-2
9.2.1.2	Freeze Operation .....	9-3
9.2.1.3	QSM Interrupts .....	9-3
9.2.2	QSM Pin Control Registers .....	9-4
9.3	Queued Serial Peripheral Interface .....	9-5
9.3.1	QSPI Registers .....	9-6
9.3.1.1	Control Registers .....	9-6
9.3.1.2	Status Register .....	9-7
9.3.2	QSPI RAM .....	9-7
9.3.2.1	Receive RAM .....	9-7
9.3.2.2	Transmit RAM .....	9-7
9.3.2.3	Command RAM .....	9-8
9.3.3	QSPI Pins .....	9-8
9.3.4	QSPI Operation .....	9-8
9.3.5	QSPI Operating Modes .....	9-9
9.3.5.1	Master Mode .....	9-16
9.3.5.2	Master Wrap-Around Mode .....	9-19
9.3.5.3	Slave Mode .....	9-19
9.3.5.4	Slave Wrap-Around Mode .....	9-20
9.3.6	Peripheral Chip Selects .....	9-20
9.4	Serial Communication Interface .....	9-21
9.4.1	SCI Registers .....	9-21
9.4.1.1	Control Registers .....	9-21
9.4.1.2	Status Register .....	9-24
9.4.1.3	Data Register .....	9-24
9.4.2	SCI Pins .....	9-24
9.4.3	SCI Operation .....	9-24
9.4.3.1	Definition of Terms .....	9-25
9.4.3.2	Serial Formats .....	9-25
9.4.3.3	Baud Clock .....	9-25
9.4.3.4	Parity Checking .....	9-26
9.4.3.5	Transmitter Operation .....	9-26
9.4.3.6	Receiver Operation .....	9-28
9.4.3.7	Idle-Line Detection .....	9-28
9.4.3.8	Receiver Wake-Up .....	9-29
9.4.3.9	Internal Loop .....	9-30
9.5	QSM Initialization .....	9-30

### SECTION 10 CONFIGURABLE TIMER MODULE 4

## TABLE OF CONTENTS (Continued)

Paragraph	Title	Page
10.1	General .....	10-1
10.2	Address Map .....	10-2
10.3	Time Base Bus System .....	10-2
10.4	Bus Interface Unit Submodule (BIUSM) .....	10-3
10.4.1	STOP Effect On the BIUSM .....	10-3
10.4.2	Freeze Effect On the BIUSM .....	10-3
10.4.3	LPSTOP Effect on the BIUSM .....	10-4
10.4.4	BIUSM Registers .....	10-4
10.5	Counter Prescaler Submodule (CPSM) .....	10-4
10.5.1	CPSM Registers .....	10-5
10.6	Free-Running Counter Submodule (FCSM) .....	10-5
10.6.1	FCSM Counter .....	10-6
10.6.2	FCSM Clock Sources .....	10-6
10.6.3	FCSM External Event Counting .....	10-6
10.6.4	FCSM Time Base Bus Driver .....	10-6
10.6.5	FCSM Interrupts .....	10-6
10.6.6	FCSM Registers .....	10-7
10.7	Modulus Counter Submodule (MCSM) .....	10-7
10.7.1	MCSM Modulus Latch .....	10-8
10.7.2	MCSM Counter .....	10-8
10.7.2.1	Loading the MCSM Counter Register .....	10-8
10.7.2.2	Using the MCSM as a Free-Running Counter .....	10-9
10.7.3	MCSM Clock Sources .....	10-9
10.7.4	MCSM External Event Counting .....	10-9
10.7.5	MCSM Time Base Bus Driver .....	10-9
10.7.6	MCSM Interrupts .....	10-9
10.7.7	MCSM Registers .....	10-10
10.8	Double-Action Submodule (DASM) .....	10-10
10.8.1	DASM Interrupts .....	10-12
10.8.2	DASM Registers .....	10-12
10.9	Pulse-Width Modulation Submodule (PWMSM) .....	10-12
10.9.1	Output Flip-Flop and Pin .....	10-13
10.9.2	Clock Selection .....	10-13
10.9.3	PWMSM Counter .....	10-14
10.9.4	PWMSM Period Registers and Comparator .....	10-14
10.9.5	PWMSM Pulse-Width Registers and Comparator .....	10-15
10.9.6	PWMSM Coherency .....	10-15
10.9.7	PWMSM Interrupts .....	10-15
10.9.8	PWM Frequency .....	10-16
10.9.9	PWM Pulse Width .....	10-17
10.9.10	PWM Period and Pulse Width Register Values .....	10-17

## TABLE OF CONTENTS (Continued)

Paragraph	Title	Page
10.9.10.1	PWM Duty Cycle Boundary Cases .....	10-17
10.9.11	PWMSM Registers .....	10-17
10.10	CTM4 Interrupts .....	10-18

### SECTION 11 TIME PROCESSOR UNIT

11.1	General .....	11-1
11.2	TPU Components .....	11-2
11.2.1	Time Bases .....	11-2
11.2.2	Timer Channels .....	11-2
11.2.3	Scheduler .....	11-3
11.2.4	Microengine .....	11-3
11.2.5	Host Interface .....	11-3
11.2.6	Parameter RAM .....	11-3
11.3	TPU Operation .....	11-3
11.3.1	Event Timing .....	11-4
11.3.2	Channel Orthogonality .....	11-4
11.3.3	Interchannel Communication .....	11-4
11.3.4	Programmable Channel Service Priority .....	11-4
11.3.5	Coherency .....	11-4
11.3.6	Emulation Support .....	11-5
11.3.7	TPU Interrupts .....	11-5
11.4	A Mask Set Time Functions .....	11-6
11.4.1	Discrete Input/Output (DIO) .....	11-6
11.4.2	Input Capture/Input Transition Counter (ITC) .....	11-6
11.4.3	Output Compare (OC) .....	11-7
11.4.4	Pulse-Width Modulation (PWM) .....	11-7
11.4.5	Synchronized Pulse-Width Modulation (SPWM) .....	11-7
11.4.6	Period Measurement with Additional Transition Detect (PMA) .....	11-8
11.4.7	Period Measurement with Missing Transition Detect (PMM) .....	11-8
11.4.8	Position-Synchronized Pulse Generator (PSP) .....	11-8
11.4.9	Stepper Motor (SM) .....	11-9
11.4.10	Period/Pulse-Width Accumulator (PPWA) .....	11-9
11.4.11	Quadrature Decode (QDEC) .....	11-10
11.5	G Mask Set Time Functions .....	11-10
11.5.1	Table Stepper Motor (TSM) .....	11-10
11.5.2	New Input Capture/Transition Counter (NITC) .....	11-11
11.5.3	Queued Output Match (QOM) .....	11-11
11.5.4	Programmable Time Accumulator (PTA) .....	11-11
11.5.5	Multichannel Pulse-Width Modulation (MCPWM) .....	11-11
11.5.6	Fast Quadrature Decode (FQD) .....	11-12
11.5.7	Universal Asynchronous Receiver/Transmitter (UART) .....	11-12

## TABLE OF CONTENTS (Continued)

Paragraph	Title	Page
11.5.8	Brushless Motor Commutation (COMM) .....	11-12
11.5.9	Frequency Measurement (FQM) .....	11-13
11.5.10	Hall Effect Decode (HALLD) .....	11-13
11.6	Host Interface Registers .....	11-13
11.6.1	System Configuration Registers .....	11-13
11.6.1.1	Prescaler Control for TCR1 .....	11-13
11.6.1.2	Prescaler Control for TCR2 .....	11-14
11.6.1.3	Emulation Control .....	11-15
11.6.1.4	Low-Power Stop Control .....	11-15
11.6.2	Channel Control Registers .....	11-15
11.6.2.1	Channel Interrupt Enable and Status Registers .....	11-15
11.6.2.2	Channel Function Select Registers .....	11-16
11.6.2.3	Host Sequence Registers .....	11-16
11.6.2.4	Host Service Registers .....	11-17
11.6.2.5	Channel Priority Registers .....	11-17
11.6.3	Development Support and Test Registers .....	11-17

### SECTION 12 STANDBY RAM WITH TPU EMULATION

12.1	General .....	12-1
12.2	TPURAM Register Block .....	12-1
12.3	TPURAM Array Address Mapping .....	12-1
12.4	TPURAM Privilege Level .....	12-2
12.5	Normal Operation .....	12-2
12.6	Standby Operation .....	12-2
12.7	Low-Power Stop Operation .....	12-3
12.8	Reset .....	12-3
12.9	TPU Microcode Emulation .....	12-3

### SECTION 13 CAN 2.0B CONTROLLER MODULE (TouCAN)

13.1	General .....	13-1
13.2	External Pins .....	13-2
13.3	Programmer's Model .....	13-2
13.4	TouCAN Architecture .....	13-3
13.4.1	TX/RX Message Buffer Structure .....	13-3
13.4.1.1	Common Fields for Extended and Standard Format Frames .....	13-4
13.4.1.2	Fields for Extended Format Frames .....	13-5
13.4.1.3	Fields for Standard Format Frames .....	13-5
13.4.1.4	Serial Message Buffers .....	13-6
13.4.1.5	Message Buffer Activation/Deactivation Mechanism .....	13-6
13.4.1.6	Message Buffer Lock/Release/Busy Mechanism .....	13-6

## TABLE OF CONTENTS (Continued)

Paragraph	Title	Page
13.4.2	Receive Mask Registers .....	13-7
13.4.3	Bit Timing .....	13-8
13.4.3.1	Configuring the TouCAN Bit Timing .....	13-9
13.4.4	Error Counters .....	13-9
13.4.5	Time Stamp .....	13-10
13.5	TouCAN Operation .....	13-11
13.5.1	TouCAN Reset .....	13-11
13.5.2	TouCAN Initialization .....	13-11
13.5.3	Transmit Process .....	13-12
13.5.3.1	Transmit Message Buffer Deactivation .....	13-13
13.5.3.2	Reception of Transmitted Frames .....	13-13
13.5.4	Receive Process .....	13-13
13.5.4.1	Receive Message Buffer Deactivation .....	13-14
13.5.4.2	Locking and Releasing Message Buffers .....	13-15
13.5.5	Remote Frames .....	13-15
13.5.6	Overload Frames .....	13-16
13.6	Special Operating Modes .....	13-16
13.6.1	Debug Mode .....	13-16
13.6.2	Low-Power Stop Mode .....	13-17
13.6.3	Auto Power Save Mode .....	13-18
13.7	Interrupts .....	13-19

### APPENDIX A ELECTRICAL CHARACTERISTICS

### APPENDIX B MECHANICAL DATA AND ORDERING INFORMATION

B.1	Obtaining Updated MC68336/376 Mechanical Information .....	B-4
B.2	Ordering Information .....	B-4

### APPENDIX C DEVELOPMENT SUPPORT

C.1	M68MMDS1632 Modular Development System .....	C-1
C.2	M68MEVB1632 Modular Evaluation Board .....	C-1

### APPENDIX D REGISTER SUMMARY

D.1	Central Processor Unit .....	D-1
D.1.1	CPU32 Register Model .....	D-2
D.1.2	Status Register .....	D-3
D.2	System Integration Module .....	D-5
D.2.1	SIM Configuration Register .....	D-6
D.2.2	System Integration Test Register .....	D-7

## TABLE OF CONTENTS (Continued)

Paragraph	Title	Page
D.2.3	Clock Synthesizer Control Register .....	D-8
D.2.4	Reset Status Register .....	D-9
D.2.5	System Integration Test Register (ECLK) .....	D-9
D.2.6	Port E Data Register .....	D-10
D.2.7	Port E Data Direction Register .....	D-10
D.2.8	Port E Pin Assignment Register .....	D-10
D.2.9	Port F Data Register .....	D-11
D.2.10	Port F Data Direction Register .....	D-11
D.2.11	Port F Pin Assignment Register .....	D-11
D.2.12	System Protection Control Register .....	D-12
D.2.13	Periodic Interrupt Control Register .....	D-13
D.2.14	Periodic Interrupt Timer Register .....	D-14
D.2.15	Software Watchdog Service Register .....	D-14
D.2.16	Port C Data Register .....	D-15
D.2.17	Chip-Select Pin Assignment Registers .....	D-15
D.2.18	Chip-Select Base Address Register Boot ROM .....	D-17
D.2.19	Chip-Select Base Address Registers .....	D-17
D.2.20	Chip-Select Option Register Boot ROM .....	D-18
D.2.21	Chip-Select Option Registers .....	D-18
D.2.22	Master Shift Registers .....	D-21
D.2.23	Test Module Shift Count Register .....	D-21
D.2.24	Test Module Repetition Count Register .....	D-21
D.2.25	Test Submodule Control Register .....	D-21
D.2.26	Distributed Register .....	D-21
D.3	Standby RAM Module .....	D-22
D.3.1	RAM Module Configuration Register .....	D-22
D.3.2	RAM Test Register .....	D-23
D.3.3	Array Base Address Register High .....	D-23
D.3.4	Array Base Address Register Low .....	D-23
D.4	Masked ROM Module .....	D-24
D.4.1	Masked ROM Module Configuration Register .....	D-24
D.4.2	ROM Array Base Address Register High .....	D-26
D.4.3	ROM Array Base Address Register Low .....	D-26
D.4.4	ROM Signature High Register .....	D-26
D.4.5	ROM Signature Low Register .....	D-26
D.4.6	ROM Bootstrap Words .....	D-27
D.5	QADC Module .....	D-28
D.5.1	QADC Module Configuration Register .....	D-28
D.5.2	QADC Test Register .....	D-29
D.5.3	QADC Interrupt Register .....	D-29
D.5.4	Port A/B Data Register .....	D-30

## TABLE OF CONTENTS (Continued)

Paragraph	Title	Page
D.5.5	Port Data Direction Register .....	D-30
D.5.6	QADC Control Registers .....	D-31
D.5.7	QADC Status Register .....	D-35
D.5.8	Conversion Command Word Table .....	D-37
D.5.9	Result Word Table .....	D-39
D.6	Queued Serial Module .....	D-40
D.6.1	QSM Configuration Register .....	D-40
D.6.2	QSM Test Register .....	D-41
D.6.3	QSM Interrupt Level Register .....	D-41
D.6.4	QSM Interrupt Vector Register .....	D-42
D.6.5	SCI Control Register .....	D-42
D.6.7	SCI Status Register .....	D-45
D.6.8	SCI Data Register .....	D-46
D.6.9	Port QS Data Register .....	D-46
D.6.10	Port QS Pin Assignment Register/Data Direction Register .....	D-47
D.6.11	QSPI Control Register 0 .....	D-48
D.6.12	QSPI Control Register 1 .....	D-50
D.6.13	QSPI Control Register 2 .....	D-51
D.6.14	QSPI Control Register 3 .....	D-52
D.6.15	QSPI Status Register .....	D-53
D.6.16	Receive Data RAM .....	D-53
D.6.17	Transmit Data RAM .....	D-54
D.6.18	Command RAM .....	D-54
D.7	Configurable Timer Module 4 .....	D-56
D.7.1	BIU Module Configuration Register .....	D-57
D.7.2	BIUSM Test Configuration Register .....	D-58
D.7.3	BIUSM Time Base Register .....	D-58
D.7.4	CPSM Control Register .....	D-58
D.7.5	CPSM Test Register .....	D-59
D.7.6	FCSM Status/Interrupt/Control Register .....	D-59
D.7.7	FCSM Counter Register .....	D-61
D.7.8	MCSM Status/Interrupt/Control Registers .....	D-61
D.7.9	MCSM Counter Registers .....	D-63
D.7.10	MCSM Modulus Latch Registers .....	D-63
D.7.11	DASM Status/Interrupt/Control Registers .....	D-63
D.7.12	DASM Data Register A .....	D-66
D.7.13	DASM Data Register B .....	D-67
D.7.14	PWM Status/Interrupt/Control Register .....	D-68
D.7.15	PWM Period Register .....	D-71
D.7.16	PWM Pulse Width Register .....	D-71
D.7.17	PWM Counter Register .....	D-72

## TABLE OF CONTENTS (Continued)

Paragraph	Title	Page
D.8	Time Processor Unit (TPU) .....	D-73
D.8.1	TPU Module Configuration Register .....	D-73
D.8.2	Test Configuration Register .....	D-75
D.8.3	Development Support Control Register .....	D-75
D.8.4	Development Support Status Register .....	D-76
D.8.5	TPU Interrupt Configuration Register .....	D-77
D.8.6	Channel Interrupt Enable Register .....	D-77
D.8.7	Channel Function Select Registers .....	D-78
D.8.8	Host Sequence Registers .....	D-78
D.8.9	Host Service Request Registers .....	D-79
D.8.10	Channel Priority Registers .....	D-79
D.8.11	Channel Interrupt Status Register .....	D-80
D.8.12	Link Register .....	D-80
D.8.13	Service Grant Latch Register .....	D-80
D.8.14	Decoded Channel Number Register .....	D-80
D.8.15	TPU Parameter RAM .....	D-80
D.9	Standby RAM Module with TPU Emulation Capability (TPURAM) .....	D-82
D.9.1	TPURAM Module Configuration Register .....	D-82
D.9.2	TPURAM Test Register .....	D-82
D.9.3	TPURAM Module Configuration Register .....	D-82
D.10	TouCAN Module .....	D-84
D.10.1	TouCAN Module Configuration Register .....	D-85
D.10.2	TouCAN Test Configuration Register .....	D-88
D.10.3	TouCAN Interrupt Configuration Register .....	D-88
D.10.4	Control Register 0 .....	D-88
D.10.5	Control Register 1 .....	D-90
D.10.6	Prescaler Divide Register .....	D-91
D.10.7	Control Register 2 .....	D-91
D.10.8	Free Running Timer .....	D-92
D.10.9	Receive Global Mask Registers .....	D-93
D.10.10	Receive Buffer 14 Mask Registers .....	D-93
D.10.11	Receive Buffer 15 Mask Registers .....	D-93
D.10.12	Error and Status Register .....	D-94
D.10.13	Interrupt Mask Register .....	D-96
D.10.14	Interrupt Flag Register .....	D-96
D.10.15	Error Counters .....	D-97



## LIST OF ILLUSTRATIONS

Figure	Title	Page
3-1	MC68336/376 Block Diagram .....	3-4
3-2	MC68336 Pin Assignments for 160-Pin Package .....	3-5
3-3	MC68376 Pin Assignments for 160-Pin Package .....	3-6
3-4	MC68336/376 Address Map .....	3-13
3-5	Overall Memory Map .....	3-15
3-6	Separate Supervisor and User Space Map .....	3-16
3-7	Supervisor Space (Separate Program/Data Space) Map .....	3-17
3-8	User Space (Separate Program/Data Space) Map .....	3-18
4-1	CPU32 Block Diagram .....	4-2
4-2	User Programming Model .....	4-3
4-3	Supervisor Programming Model Supplement .....	4-4
4-4	Data Organization in Data Registers .....	4-5
4-5	Address Organization in Address Registers .....	4-6
4-6	Memory Operand Addressing .....	4-8
4-7	Loop Mode Instruction Sequence .....	4-15
4-8	Common In-Circuit Emulator Diagram .....	4-19
4-9	Bus State Analyzer Configuration .....	4-19
4-10	Debug Serial I/O Block Diagram .....	4-24
4-11	BDM Serial Data Word .....	4-25
4-12	BDM Connector Pinout .....	4-25
5-1	System Integration Module Block Diagram .....	5-2
5-2	System Clock Block Diagram .....	5-4
5-3	System Clock Oscillator Circuit .....	5-5
5-4	System Clock Filter Networks .....	5-6
5-5	LPSTOP Flowchart .....	5-13
5-6	System Protection Block .....	5-14
5-7	Periodic Interrupt Timer and Software Watchdog Timer .....	5-17
5-8	MCU Basic System .....	5-20
5-9	Operand Byte Order .....	5-25
5-10	Word Read Cycle Flowchart .....	5-28
5-11	Write Cycle Flowchart .....	5-29
5-12	CPU Space Address Encoding .....	5-31
5-13	Breakpoint Operation Flowchart .....	5-33
5-14	LPSTOP Interrupt Mask Level .....	5-34
5-15	Bus Arbitration Flowchart for Single Request .....	5-39
5-16	Preferred Circuit for Data Bus Mode Select Conditioning .....	5-43
5-17	Alternate Circuit for Data Bus Mode Select Conditioning .....	5-44
5-18	Power-On Reset .....	5-49
5-19	Basic MCU System .....	5-55
5-20	Chip-Select Circuit Block Diagram .....	5-56
5-21	CPU Space Encoding for Interrupt Acknowledge .....	5-61

## LIST OF ILLUSTRATIONS (Continued)

Figure	Title	Page
8-1	QADC Block Diagram .....	8-1
8-2	QADC Input and Output Signals .....	8-3
8-3	Example of External Multiplexing .....	8-11
8-4	QADC Module Block Diagram .....	8-13
8-5	Conversion Timing .....	8-14
8-6	Bypass Mode Conversion Timing .....	8-15
8-7	QADC Queue Operation with Pause .....	8-18
8-8	QADC Clock Subsystem Functions .....	8-24
8-9	QADC Clock Programmability Examples .....	8-26
8-10	QADC Conversion Queue Operation .....	8-29
8-11	QADC Interrupt Vector Format .....	8-33
9-1	QSM Block Diagram .....	9-1
9-2	QSPI Block Diagram .....	9-5
9-3	QSPI RAM .....	9-7
9-4	Flowchart of QSPI Initialization Operation .....	9-10
9-5	Flowchart of QSPI Master Operation (Part 1) .....	9-11
9-6	Flowchart of QSPI Master Operation (Part 2) .....	9-12
9-7	Flowchart of QSPI Master Operation (Part 3) .....	9-13
9-8	Flowchart of QSPI Slave Operation (Part 1) .....	9-14
9-9	Flowchart of QSPI Slave Operation (Part 2) .....	9-15
9-10	SCI Transmitter Block Diagram .....	9-22
9-11	SCI Receiver Block Diagram .....	9-23
10-1	CTM4 Block Diagram .....	10-1
10-2	CPSM Block Diagram .....	10-4
10-3	FCSM Block Diagram .....	10-5
10-4	MCSM Block Diagram .....	10-8
10-5	DASM Block Diagram .....	10-11
10-6	Pulse-Width Modulation Submodule Block Diagram .....	10-13
11-1	TPU Block Diagram .....	11-1
11-2	TCR1 Prescaler Control .....	11-14
11-3	TCR2 Prescaler Control .....	11-14
13-1	TouCAN Block Diagram .....	13-1
13-2	Typical CAN Network .....	13-2
13-3	Extended ID Message Buffer Structure .....	13-3
13-4	Standard ID Message Buffer Structure .....	13-4
13-5	TouCAN Interrupt Vector Generation .....	13-19
A-1	CLKOUT Output Timing Diagram .....	A-10
A-2	External Clock Input Timing Diagram .....	A-10
A-3	ECLK Output Timing Diagram .....	A-10
A-4	Read Cycle Timing Diagram .....	A-11
A-5	Write Cycle Timing Diagram .....	A-12

## LIST OF ILLUSTRATIONS (Continued)

Figure	Title	Page
A-6	Fast Termination Read Cycle Timing Diagram .....	A-13
A-7	Fast Termination Write Cycle Timing Diagram .....	A-14
A-8	Bus Arbitration Timing Diagram — Active Bus Case .....	A-15
A-9	Bus Arbitration Timing Diagram — Idle Bus Case .....	A-16
A-10	Show Cycle Timing Diagram .....	A-17
A-11	Chip-Select Timing Diagram .....	A-18
A-12	Reset and Mode Select Timing Diagram .....	A-18
A-13	Background Debugging Mode Timing — Serial Communication .....	A-20
A-14	Background Debugging Mode Timing — Freeze Assertion .....	A-20
A-15	ECLK Timing Diagram .....	A-22
A-16	QSPI Timing — Master, CPHA = 0 .....	A-24
A-17	QSPI Timing — Master, CPHA = 1 .....	A-24
A-18	QSPI Timing — Slave, CPHA = 0 .....	A-25
A-19	QSPI Timing — Slave, CPHA = 1 .....	A-25
A-20	TPU Timing Diagram .....	A-26
B-1	MC68336 Pin Assignments for 160-Pin Package .....	B-1
B-2	MC68376 Pin Assignments for 160-Pin Package .....	B-2
B-3	160-Pin Package Dimensions .....	B-3
D-1	User Programming Model .....	D-2
D-2	Supervisor Programming Model Supplement .....	D-3
D-3	TouCAN Message Buffer Address Map .....	D-85

**LIST OF ILLUSTRATIONS**  
**(Continued)**  
**Title**

**Figure**

**Page**

## LIST OF TABLES

Table	Title	Page
3-1	MC68336/376 Pin Characteristics .....	3-7
3-2	MC68336/376 Output Driver Types.....	3-8
3-3	MC68336/376 Power Connections.....	3-8
3-4	MC68336/376 Signal Characteristics .....	3-9
3-5	MC68336/376 Signal Functions .....	3-11
4-1	Unimplemented MC68020 Instructions .....	4-10
4-2	Instruction Set Summary .....	4-11
4-3	Exception Vector Assignments.....	4-16
4-4	BDM Source Summary.....	4-20
4-5	Polling the BDM Entry Source.....	4-21
4-6	Background Mode Command Summary .....	4-22
4-7	CPU Generated Message Encoding .....	4-25
5-1	Show Cycle Enable Bits .....	5-3
5-2	Clock Control Multipliers.....	5-8
5-3	System Frequencies from 4.194 MHz Reference .....	5-10
5-4	Bus Monitor Period.....	5-15
5-5	MODCLK Pin and SWP Bit During Reset .....	5-16
5-6	Software Watchdog Ratio.....	5-16
5-7	MODCLK Pin and PTP Bit at Reset .....	5-17
5-8	Periodic Interrupt Priority.....	5-18
5-9	Size Signal Encoding .....	5-22
5-10	Address Space Encoding .....	5-23
5-11	Effect of DSACK Signals .....	5-24
5-12	Operand Alignment .....	5-26
5-13	DSACK, BERR, and HALT Assertion Results.....	5-35
5-14	Reset Source Summary .....	5-41
5-15	Reset Mode Selection .....	5-42
5-16	Module Pin Functions During Reset.....	5-46
5-17	SIM Pin Reset States .....	5-47
5-18	Chip-Select Pin Functions .....	5-57
5-19	Pin Assignment Field Encoding.....	5-58
5-20	Block Size Encoding.....	5-59
5-21	Chip-Select Base and Option Register Reset Values .....	5-63
5-22	CSBOOT Base and Option Register Reset Values.....	5-63
6-1	SRAM Array Address Space Type .....	6-2
7-1	ROM Array Space Type .....	7-2
7-2	Wait States Field .....	7-2
8-1	Multiplexed Analog Input Channels.....	8-5
8-2	Analog Input Channels .....	8-12
8-3	Queue 1 Priority Assertion .....	8-17
8-4	QADC Clock Programmability .....	8-27

## LIST OF TABLES (Continued)

Table	Title	Page
8-5	QADC Status Flags and Interrupt Sources .....	8-32
9-1	Effect of DDRQS on QSM Pin Function .....	9-4
9-2	QSPI Pins .....	9-8
9-3	Bits Per Transfer .....	9-17
9-4	SCI Pins .....	9-24
9-5	Serial Frame Formats.....	9-25
9-6	Effect of Parity Checking on Data Size .....	9-26
10-1	CTM4 Time Base Bus Allocation.....	10-3
10-2	DASM Modes of Operation .....	10-10
10-3	Channel B Data Register Access .....	10-11
10-4	PWMSM Divide By Options.....	10-14
10-5	PWM Pulse and Frequency Ranges (in Hz) Using ÷ 2 Option (20.97 MHz) .....	10-16
10-6	PWM Pulse and Frequency Ranges (in Hz) Using ÷ 3 Option (20.97 MHz) .....	10-16
10-7	CTM4 Interrupt Priority and Vector/Pin Allocation .....	10-18
11-1	TCR1 Prescaler Control .....	11-14
11-2	TCR2 Prescaler Control .....	11-15
11-3	TPU Function Encodings.....	11-16
11-4	Channel Priority Encodings .....	11-17
13-1	Common Extended/Standard Format Frames .....	13-4
13-2	Message Buffer Codes for Receive Buffers .....	13-4
13-3	Message Buffer Codes for Transmit Buffers .....	13-5
13-4	Extended Format Frames.....	13-5
13-5	Standard Format Frames .....	13-6
13-6	Receive Mask Register Bit Values .....	13-7
13-7	Mask Examples for Normal/Extended Messages.....	13-8
13-8	Example System Clock, CAN Bit Rate and S-Clock Frequencies.....	13-9
13-9	Interrupt Sources and Vector Addresses .....	13-20
A-1	Maximum Ratings.....	A-1
A-2	Typical Ratings .....	A-2
A-3	Thermal Characteristics .....	A-2
A-4	Clock Control Timing .....	A-3
A-5	DC Characteristics .....	A-4
A-6	AC Timing.....	A-7
A-7	Background Debug Mode Timing.....	A-19
A-8	ECLK Bus Timing .....	A-21
A-9	QSPI Timing .....	A-23
A-10	Time Processor Unit Timing .....	A-26
A-11	QADC Maximum Ratings .....	A-27
A-12	QADC DC Electrical Characteristics (Operating) .....	A-28
A-13	QADC AC Electrical Characteristics (Operating) .....	A-29
A-14	QADC Conversion Characteristics (Operating).....	A-30

## LIST OF TABLES (Continued)

Table	Title	Page
A-15	FCSM Timing Characteristics.....	A-31
A-16	MCSM Timing Characteristics.....	A-31
A-17	SASM Timing Characteristics.....	A-32
A-18	DASM Timing Characteristics.....	A-33
A-19	PWMSM Timing Characteristics.....	A-34
B-1	MC68336 Ordering Information.....	B-4
B-2	MC68376 Ordering Information.....	B-5
D-1	Module Address Map.....	D-1
D-2	T[1:0] Encoding.....	D-3
D-3	SIM Address Map.....	D-5
D-4	Show Cycle Enable Bits.....	D-7
D-5	Port E Pin Assignments.....	D-11
D-6	Port F Pin Assignments.....	D-12
D-7	Software Watchdog Timing Field.....	D-13
D-8	Bus Monitor Time-Out Period.....	D-13
D-9	Pin Assignment Field Encoding.....	D-15
D-10	CSPAR0 Pin Assignments.....	D-16
D-11	CSPAR1 Pin Assignments.....	D-16
D-12	Reset Pin Function of CS[10:6].....	D-17
D-13	Block Size Field Bit Encoding.....	D-18
D-14	BYTE Field Bit Encoding.....	D-19
D-15	Read/Write Field Bit Encoding.....	D-19
D-16	DSACK Field Encoding.....	D-20
D-17	Address Space Bit Encodings.....	D-20
D-18	Interrupt Priority Level Field Encoding.....	D-20
D-19	SRAM Address Map.....	D-22
D-20	RASP Encoding.....	D-22
D-21	MRM Address Map.....	D-24
D-22	ROM Array Space Field.....	D-25
D-23	Wait States Field.....	D-25
D-24	QADC Address Map.....	D-28
D-25	Queue 1 Operating Modes.....	D-32
D-26	Queue 2 Operating Modes.....	D-34
D-27	Queue Status.....	D-36
D-28	Input Sample Times.....	D-37
D-29	Non-multiplexed Channel Assignments and Pin Designations.....	D-38
D-30	Multiplexed Channel Assignments and Pin Designations.....	D-38
D-31	QSM Address Map.....	D-40
D-32	PQSPAR Pin Assignments.....	D-47
D-33	Effect of DDRQS on QSM Pin Function.....	D-48
D-34	Bits Per Transfer.....	D-49

## LIST OF TABLES (Continued)

Table	Title	Page
D-35	CTM4 Address Map .....	D-56
D-36	Interrupt Vector Base Number Bit Field.....	D-57
D-37	Time Base Register Bus Select Bits.....	D-58
D-38	Prescaler Division Ratio Select Field .....	D-59
D-39	Drive Time Base Bus Field.....	D-60
D-40	Counter Clock Select Field.....	D-60
D-41	Drive Time Base Bus Field.....	D-62
D-42	Modulus Load Edge Sensitivity Bits .....	D-62
D-43	Counter Clock Select Field.....	D-62
D-44	DASM Mode Flag Status Bit States .....	D-64
D-45	Edge Polarity .....	D-65
D-46	DASM Mode Select Field .....	D-66
D-47	DASMA Operations .....	D-67
D-48	DASMB Operations .....	D-68
D-49	PWMSM Output Pin Polarity Selection .....	D-70
D-50	PWMSM Divide By Options.....	D-71
D-51	TPU Register Map .....	D-73
D-52	TCR1 Prescaler Control Bits .....	D-74
D-53	TCR2 Prescaler Control Bits .....	D-74
D-54	FRZ[1:0] Encoding .....	D-76
D-55	Breakpoint Enable Bits.....	D-76
D-56	Channel Priorities .....	D-80
D-57	Parameter RAM Address Map .....	D-81
D-58	TPURAM Address Map.....	D-82
D-59	TouCAN Address Map .....	D-84
D-60	RX MODE[1:0] Configuration .....	D-89
D-61	Transmit Pin Configuration.....	D-89
D-62	Transmit Bit Error Status .....	D-94
D-63	Fault Confinement State Encoding.....	D-95



## SECTION 1 INTRODUCTION

The MC68336 and the MC68376 are highly-integrated 32-bit microcontrollers, combining high-performance data manipulation capabilities with powerful peripheral subsystems.

MC68300 microcontrollers are built up from standard modules that interface through a common intermodule bus (IMB). Standardization facilitates rapid development of devices tailored for specific applications.

The MC68336 incorporates a 32-bit CPU (CPU32), a system integration module (SIM), a time processor unit (TPU), a configurable timer module (CTM4), a queued serial module (QSM), a 10-bit queued analog-to-digital converter module (QADC), a 3.5-Kbyte TPU emulation RAM module (TPURAM), and a 4-Kbyte standby RAM module (SRAM).

The MC68376 includes all of the aforementioned modules, plus a CAN 2.0B protocol controller module (TouCAN™) and an 8-Kbyte masked ROM (MRM).

The MC68336/376 can either synthesize the system clock signal from a fast reference or use an external clock input directly. Operation with a 4.194 MHz reference frequency is standard. The maximum system clock speed is 20.97 MHz. System hardware and software allow changes in clock rate during operation. Because MCU operation is fully static, register and memory contents are not affected by clock rate changes.

High-density complementary metal-oxide semiconductor (HCMOS) architecture makes the basic power consumption of the MCU low. Power consumption can be minimized by stopping the system clock. The CPU32 instruction set includes a low-power stop (LPSTOP) instruction that efficiently implements this capability.

Documentation for the Modular Microcontroller Family follows the modular construction of the devices in the product line. Each microcontroller has a comprehensive user's manual that provides sufficient information for normal operation of the device. The user's manual is supplemented by module reference manuals that provide detailed information about module operation and applications. Refer to Motorola publication *Advanced Microcontroller Unit (AMCU) Literature* (BR1116/D) for a complete listing of documentation.



## SECTION 2 NOMENCLATURE

The following nomenclature is used throughout the manual. Nomenclature used only in certain sections, such as register bit mnemonics, is defined in those sections.

### 2.1 Symbols and Operators

+	—	Addition
-	—	Subtraction or negation (two's complement)
*	—	Multiplication
/	—	Division
>	—	Greater
<	—	Less
=	—	Equal
≥	—	Equal or greater
≤	—	Equal or less
≠	—	Not equal
•	—	AND
⊕	—	Inclusive OR (OR)
⊕	—	Exclusive OR (EOR)
$\overline{\text{NOT}}$	—	Complementation
:	—	Concatenation
⇒	—	Transferred
↔	—	Exchanged
±	—	Sign bit; also used to show tolerance
«	—	Sign extension
%	—	Binary value
\$	—	Hexadecimal value

## 2.2 CPU32 Registers

- A6–A0 — Address registers (index registers)
- A7 (SSP) — Supervisor stack pointer
- A7 (USP) — User stack pointer
- CCR — Condition code register (user portion of SR)
- D7–D0 — Data registers (index registers)
- DFC — Alternate function code register
- PC — Program counter
- SFC — Alternate function code register
- SR — Status register
- VBR — Vector base register
- X — Extend indicator
- N — Negative indicator
- Z — Zero indicator
- V — Two's complement overflow indicator
- C — Carry/borrow indicator

## 2.3 Pin and Signal Mnemonics

- ADDR[23:0] — Address Bus
- AN[59:48]/[3:0] — QADC Analog Input
- AN[w, x, y, z] — QADC Analog Input
- $\overline{AS}$  — Address Strobe
- $\overline{AVEC}$  — Autovector
- $\overline{BERR}$  — Bus Error
- $\overline{BG}$  — Bus Grant
- $\overline{BGACK}$  — Bus Grant Acknowledge
- $\overline{BKPT}$  — Breakpoint
- $\overline{BR}$  — Bus Request
- CANRX0 — TouCAN Receive Data
- CANTX0 — TouCAN Transmit Data
- CLKOUT — System Clock
- $\overline{CS}[10:0]$  — Chip Selects
- $\overline{CSBOOT}$  — Boot ROM Chip Select
- CPWM[8:5] — CTM Pulse Width Modulation Channel
- CTD[10:9]/[4:3] — CTM Double Action Channel
- CTM2C — CTM Modulus Clock
- DATA[15:0] — Data Bus
- $\overline{DS}$  — Data Strobe

$\overline{DSACK}[1:0]$	— Data and Size Acknowledge
DSCLK	— Development Serial Clock
DSI	— Development Serial Input
DSO	— Development Serial Output
ECLK	— MC6800 Devices and Peripherals Bus Clock
ETRIG[2:1]	— QADC External Trigger
EXTAL	— Crystal Oscillator Input
FC[2:0]	— Function Codes
FREEZE	— Freeze
HALT	— Halt
$\overline{IFETCH}$	— Instruction Fetch
$\overline{IPIPE}$	— Instruction Pipeline
$\overline{IRQ}[7:1]$	— Interrupt Request
MA[2:0]	— QADC Multiplexed Address
MISO	— QSM Master In Slave Out
MODCLK	— Clock Mode Select
MOSI	— QSM Master Out Slave In
PCS[3:0]	— QSM Peripheral Chip-Selects
PQA[7:0]	— QADC Port A
PQB[7:0]	— QADC Port B
PC[6:0]	— SIM Port C
PE[7:0]	— SIM Port E
PF[7:0]	— SIM Port F
QUOT	— Quotient Out
R/W	— Read/Write
$\overline{RESET}$	— Reset
$\overline{RMC}$	— Read-Modify-Write Cycle
RXD	— SCI Receive Data
SCK	— QSPI Serial Clock
SIZ[1:0]	— Size
SS	— Slave Select
T2CLK	— TPU Clock In
TPUCH[15:0]	— TPU Channel Signals
TSC	— Three-State Control
$\overline{TSTME}$	— Test Mode Enable
$V_{RH}$	— QADC High Reference Voltage
$V_{RL}$	— QADC Low Reference Voltage
XFC	— External Filter Capacitor
XTAL	— Crystal Oscillator Output

## 2.4 Register Mnemonics

BIUMCR	—	CTM4 BIUSM Module Configuration
BIUTEST	—	CTM4 BIUSM Test Register
BIUTBR	—	CTM4 BIUSM Time Base Register
CANCTRL[0:2]		TouCAN Control Register [0:2]
CANICR	—	TouCAN Interrupt Configuration Register
IFLAG	—	TouCAN Interrupt Flags Register
IMASK	—	TouCAN Interrupt Masks Register
CANMCR	—	TouCAN Module Configuration Register
CANTCR	—	TouCAN Test Configuration Register
CCW[0:27]	—	QADC Command Conversion Words [0:27]
CFSR[0:3]	—	TPU Channel Function Select Registers [0:3]
CIER	—	TPU Channel Interrupt Enable Register
CISR	—	TPU Channel Interrupt Status Register
CPCR	—	CTM4 CPSM Control Register
CPR[0:1]	—	TPU Channel Priority Registers [0:1]
CPTR	—	CTM4 CPSM Test Register
CR[0:F]	—	QSM Command RAM
CREG	—	SIM Test Control Register C
CSBARBT	—	SIM Chip-Select Base Address Register Boot ROM
CSBAR[0:10]	—	SIM Chip-Select Base Address Registers [0:10]
CSORBT	—	SIM Chip-Select Option Register Boot ROM
CSOR[0:10]	—	SIM Chip-Select Option Registers [0:10]
CSPAR[0:1]	—	SIM Chip-Select Pin Assignment Registers [0:1]
DASM[3:4]/[9:10]A	—	CTM4 DASM A Registers [3:4]/[9:10]
DASM[3:4]/[9:10]B	—	CTM4 DASM B Registers [3:4]/[9:10]
DASM[3:4]/[9:10]SIC	—	CTM4 DASM Status/Interrupt/Control Registers [3:4]/[9:10]
DCNR	—	Decoded Channel Number Register
DDRE	—	SIM Port E Data Direction Register
DDRF	—	SIM Port F Data Direction Register
DDRQA	—	QADC Port A Data Direction Register
DDRQS	—	QSM Port QS Data Direction Register
DREG	—	SIM Test Module Distributed Register
DSCR	—	TPU Development Support Control Register
DSSR	—	TPU Development Support Status Register
ESTAT	—	TouCAN Error and Status Register

FCSM12CNT	—	CTM4 FCSM12 Counter Register
FCSM12SIC	—	CTM4 FCSM12 Status/Interrupt/Control Register
HSQR[0:1]	—	TPU Host Sequence Registers [0:1]
HSRR[0:1]	—	TPU Host Service Request Registers [0:1]
LJSRR[0:27]	—	QADC Left-Justified Signed Result Registers [0:27]
LJURR[0:27]	—	QADC Left-Justified Unsigned Result Registers [0:27]
LR	—	Link Register
MCSM[2]/[11]CNT	—	CTM4 MCSM Counter Registers [2]/[11]
MCSM[2]/[11]ML	—	CTM4 MCSM Modulus Latch Registers [2]/[11]
MCSM[2]/[11]SIC	—	CTM4 MCSM Status/Interrupt/Control Registers [2]/[11]
MRMCR	—	Masked ROM Module Configuration Register
PEPAR	—	SIM Port E Pin Assignment Register
PFPAR	—	SIM Port F Pin Assignment Register
PICR	—	SIM Periodic Interrupt Control Register
PITR	—	SIM Periodic Interrupt Timer Register
PORTC	—	SIM Port C Data Register
PORTE	—	SIM Port E Data Register
PORTF	—	SIM Port F Data Register
PORTQA	—	QADC Port A Data Register
PORTQB	—	QADC Port B Data Register
PORTQS	—	QSM Port QS Data Register
PQSPAR	—	QSM Port QS Pin Assignment Register
PRESDIV	—	TouCAN Prescaler Divide Register
PWM[5:8]C	—	CTM4 PWMSM Counter Registers [5:8]
PWM[5:8]A	—	CTM4 PWMSM Period Registers [5:8]
PWM[5:8]B	—	CTM4 PWMSM Pulse Width Registers [5:8]
PWM[5:8]SIC	—	CTM4 PWMSM Status/Interrupt/Control Registers [5:8]
QACR[0:1]	—	QADC Control Registers [0:2]
QADCINT	—	QADC Interrupt Register
QADCMCR	—	QADC Module Configuration Register
QADCTEST	—	QADC Test Register
QASR	—	QADC Status Register
QILR	—	QSM Interrupt Level Register
QIVR	—	QSM Interrupt Vector Register
QSMCR	—	QSM Module Configuration Register
QTEST	—	QSM Test Register
RAMBAH	—	RAM Base Address High Register

RAMBAL	—	RAM Base Address Low Register
RAMMCR	—	RAM Module Configuration Register
RAMTST	—	RAM Test Register
ROMBAH	—	ROM Base Address High Register
ROMBAL	—	ROM Base Address Low Register
RR[0:F]	—	QSM Receive RAM
RSIGHI	—	ROM Signature High Register
RSIGLO	—	ROM Signature Low Register
ROMBS[0:3]	—	ROM Bootstrap Words [0:3]
RXGMSKHI	—	TouCAN Receive Global Mask High Register
RXGMSKLO	—	TouCAN Receive Global Mask Low Register
RX[14:15]MSKHI	—	TouCAN Receive Buffer [14:15] Mask High Registers
RX[14:15]MSKLO	—	TouCAN Receive Buffer [14:15] Mask Low Registers
RJURR[0:27]	—	QADC Right-Justified Unsigned Result Registers
RSR	—	SIM Reset Status Register
RXECTR	—	TouCAN Receive Error Counter Register
SCCR[0:1]	—	QSM SCI Control Registers [0:1]
SCDR	—	QSM SCI Data Register
SCSR	—	QSM SCI Status Register
SGLR	—	Service Grant Latch Register
SIMCR	—	SIM Module Configuration Register
SIMTR	—	SIM System Integration Test Register
SIMTRE	—	SIM System Integration Test Register (ECLK)
SPCR[0:3]	—	QSM QSPI Control Registers [0:3]
SPSR	—	QSM QSPI Status Register
SWSR	—	SIM Software Watchdog Service Register
SYNCR	—	SIM Clock Synthesizer Control Register
SYPCR	—	SIM System Protection Control Register
TICR	—	TPU Interrupt Configuration Register
TIMER	—	TouCAN Free Running Timer Register
TPUMCR	—	TPU Module Configuration Register
TR[0:F]	—	QSM Transmit RAM
TRAMBAR	—	TPURAM Base Address Register
TRAMMCR	—	TPURAM Module Configuration Register
TRAMTST	—	TPURAM Test Register
TSTMSRA	—	SIM Test Module Master Shift Register A
TSTMSRB	—	SIM Test Module Master Shift Register B



- TSTRC — SIM Test Module Repetition Counter Register
- TSTSC — SIM Test Module Shift Count Register
- TTR — TouCAN Test Register
- TXECTR — TouCAN Transmit Error Counter Register

## 2.5 Conventions

**Logic level one** is the voltage that corresponds to a Boolean true (1) state.

**Logic level zero** is the voltage that corresponds to a Boolean false (0) state.

**Set** refers specifically to establishing logic level one on a bit or bits.

**Clear** refers specifically to establishing logic level zero on a bit or bits.

**Asserted** means that a signal is in active logic state. An active low signal changes from logic level one to logic level zero when asserted. An active high signal changes from logic level zero to logic level one.

**Negated** means that an asserted signal changes logic state. An active low signal changes from logic level zero to logic level one when negated. An active high signal changes from logic level one to logic level zero.

**A specific mnemonic** within a range is referred to by mnemonic and number. A15 is bit 15 of accumulator A; ADDR7 is line 7 of the address bus; CSOR0 is chip-select option register 0. **A range of mnemonics** is referred to by mnemonic and the numbers that define the range. VBR[4:0] are bits four to zero of the vector base register; CSOR[0:5] are the first six option registers.

**Parentheses** are used to indicate the content of a register or memory location rather than the register or memory location itself. (A) is the content of accumulator A. (M : M + 1) is the content of the word at address M.

**LSB** means least significant bit. **MSB** means most significant bit. References to low and high bytes are spelled out.

**LSW** means least significant word. **MSW** means most significant word.

**ADDR** is the address bus. ADDR[7:0] are the eight LSBs of the address bus.

**DATA** is the data bus. DATA[15:8] are the eight MSBs of the data bus.

## SECTION 3 OVERVIEW

This section contains information about the entire MC68336/376 modular microcontroller. It lists the features of each module, shows device functional divisions and pin assignments, summarizes signal and pin functions, discusses the intermodule bus, and provides system memory maps. Timing and electrical specifications for the entire microcontroller and for individual modules are provided in **APPENDIX A ELECTRICAL CHARACTERISTICS**. Comprehensive module register descriptions and memory maps are provided in **APPENDIX D REGISTER SUMMARY**.

### 3.1 MCU Features

The following paragraphs highlight capabilities of each of the microcontroller modules. Each module is discussed separately in a subsequent section of this user's manual.

#### 3.1.1 Central Processing Unit (CPU32)

- 32-bit architecture
- Virtual memory implementation
- Table look-up and interpolate instruction
- Improved exception handling for controller applications
- High level language support
- Background debug mode
- Fully static operation

#### 3.1.2 System Integration Module (SIM)

- External bus support
- Programmable chip select outputs
- System protection logic
- Watchdog timer, clock monitor and bus monitor
- Two 8-bit dual function input/output ports
- One 7-bit dual function output port
- Phase-locked loop (PLL) clock system

#### 3.1.3 Standby RAM Module (SRAM)

- 4-Kbytes of static RAM
- No standby supply

#### 3.1.4 Masked ROM Module (MRM)

- 8-Kbyte array, accessible as bytes or words
- User selectable default base address
- User selectable bootstrap ROM function
- User selectable ROM verification code

### **3.1.5 10-Bit Queued Analog-to-Digital Converter (QADC)**

- 16 channels internally; up to 44 directly accessible channels with external multiplexing
- Six automatic channel selection and conversion modes
- Two channel scan queues of variable length, each with a variable number of sub-queues
- 40 result registers and three result alignment formats
- Programmable input sample time
- Direct control of external multiplexers

### **3.1.6 Queued Serial Module (QSM)**

- Enhanced serial communications interface (SCI)
- Modulus baud rate generator
- Parity detection
- Queued serial peripheral interface (QSPI)
- 80-byte static RAM to perform queued operations
- Up to 16 automatic transfers
- Continuous cycling, 8 to 16 bits per transfer, LSB or MSB first
- Dual function I/O pins

### **3.1.7 Configurable Timer Module Version 4 (CTM4)**

- Two 16-bit modulus counter submodules (MCSMs)
- 16-bit free-running counter submodule (FCSM)
- Four double-action submodules (DASMs)
- Four pulse-width submodules (PWMSMs)

### **3.1.8 Time Processor Unit (TPU)**

- Dedicated micro-engine operating independently of the CPU32
- 16 independent programmable channels and pins
- Each channel has an event register consisting of a 16-bit capture register, a 16-bit compare register and a 16-bit comparator
- Any channel can perform any time function
- Each channel has six or eight 16-bit parameter registers
- Each timer function may be assigned to more than one channel
- Two timer counter registers with programmable prescalers
- Each channel can be synchronized to one or both counters
- Selectable channel priority levels

### **3.1.9 Static RAM Module with TPU Emulation Capability (TPURAM)**

- 3.5 Kbytes of static RAM
- External VSTBY pin for separate standby supply
- May be used as normal RAM or TPU microcode emulation RAM

### 3.1.10 CAN 2.0B Controller Module (TouCAN)

- Full implementation of CAN protocol specification, version 2.0 A and B
- 16 receive/transmit message buffers of 0 to 8 bytes data length
- Global mask register for message buffers 0 to 13
- Independent mask registers for message buffers 14 and 15
- Programmable transmit-first scheme: lowest ID or lowest buffer number
- 16-bit free-running timer for message time-stamping
- Low power sleep mode with programmable wake-up on bus activity

### 3.2 Intermodule Bus

The intermodule bus (IMB) is a standardized bus developed to facilitate both design and operation of modular microcontrollers. It contains circuitry to support exception processing, address space partitioning, multiple interrupt levels, and vectored interrupts. The standardized modules in the MCU communicate with one another through the IMB. The IMB in the MCU uses 24 address and 16 data lines.

### 3.3 System Block Diagram and Pin Assignment Diagrams

**Figure 3-1** is a functional diagram of the MCU. There is not a one-to-one correspondence between location and size of blocks in the diagram and location and size of integrated-circuit modules. **Figure 3-2** shows the MC68336 pin assignment package; **Figure 3-3** shows the MC68376 pin assignment package. Note that the MC68376 is a pin-compatible upgrade for the MC68336 that provides a CAN protocol controller and an 8-Kbyte masked ROM module. Both devices use a 160-pin plastic surface-mount package. Refer to **B.1 Obtaining Updated MC68336/376 Mechanical Information** for package dimensions. Refer to subsequent paragraphs in this section for pin and signal descriptions.

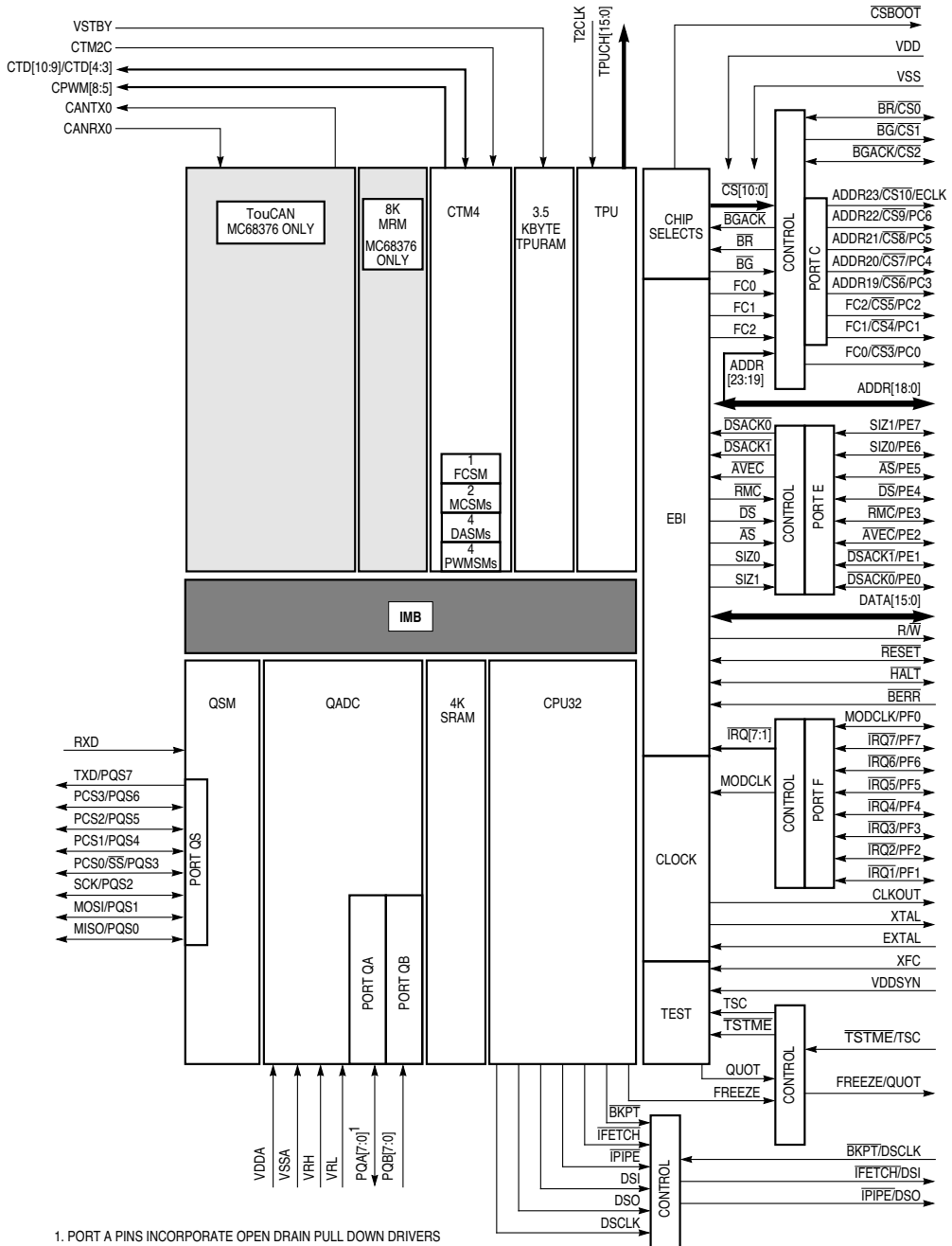

336/376 BLOCK

Figure 3-1 MC68336/376 Block Diagram

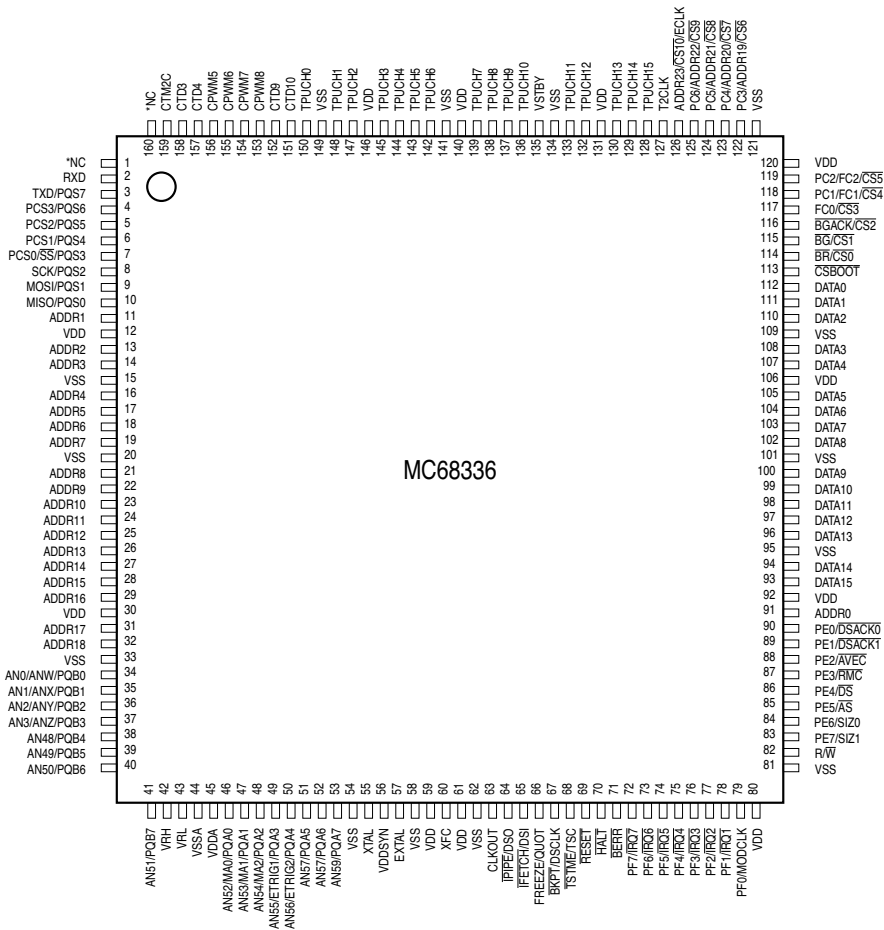

\*NOTE: MC68336 REVISION D AND LATER (F60K AND LATER MASK SETS) HAVE ASSIGNED PINS 1 AND 160 AS "NO CONNECT", TO ALLOW PIN COMPATIBILITY WITH THE MC68376. FOR REVISION C (D65J MASK SET) DEVICES, PIN 1 IS V<sub>SS</sub> AND PIN 160 IS V<sub>DD</sub>.

336 160-PIN QFP

**Figure 3-2 MC68336 Pin Assignments for 160-Pin Package**

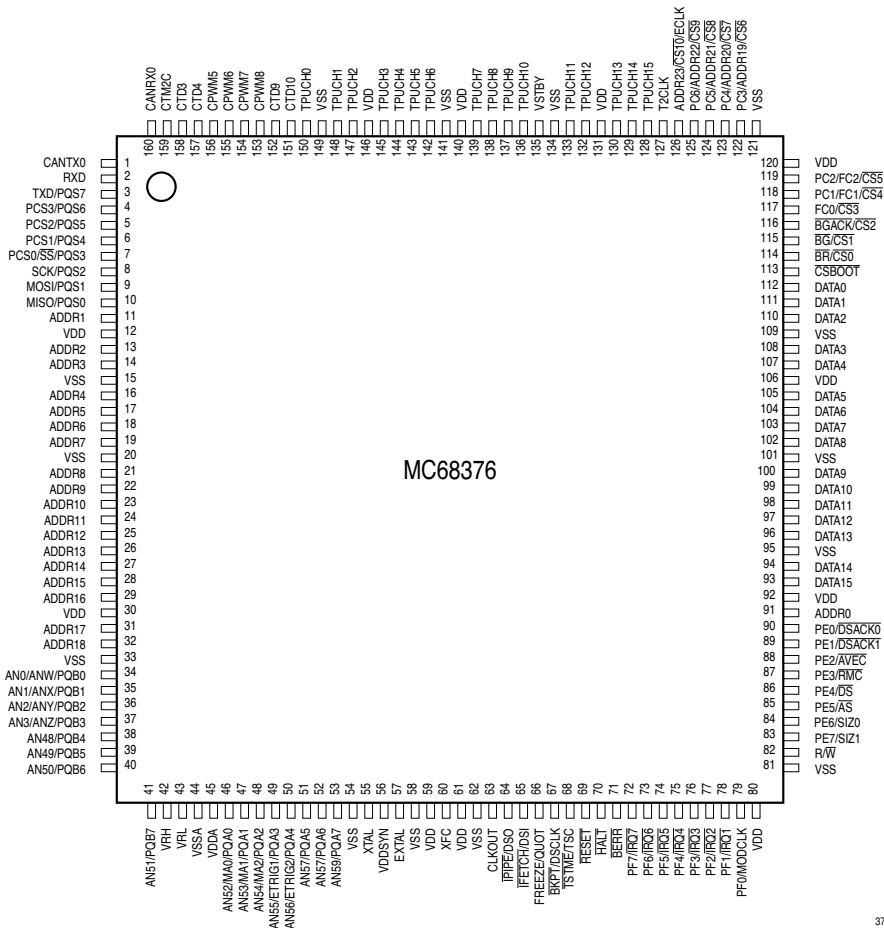

**Figure 3-3 MC68376 Pin Assignments for 160-Pin Package**

### 3.4 Pin Descriptions

The following tables summarize the functional characteristics of MC68336/376 pins. **Table 3-1** shows all inputs and outputs. Digital inputs and outputs use CMOS logic levels. An entry in the “Discrete I/O” column indicates that a pin can also be used for general-purpose input, output, or both. The I/O port designation is given when it applies. Refer to **Figure 3-1** for port organization. **Table 3-2** shows types of output drivers. **Table 3-3** shows the characteristics of power pins.



**Table 3-1 MC68336/376 Pin Characteristics**

Pin Mnemonic	Output Driver	Input Synchronized	Input Hysteresis	Discrete I/O	Port Designation
ADDR23/CS10/ECLK	A	Yes	No	O	—
ADDR[22:19]/CS[9:6]	A	Yes	No	O	PC[6:3]
ADDR[18:0]	A	Yes	No	—	—
AN[51:48]	—	Yes <sup>1</sup>	Yes	I	PQB[7:4]
AN[3:0]/AN[w, x, y, z]	—	Yes <sup>1</sup>	Yes	I	PQB[3:0]
AN[59:57]	Ba	Yes	Yes	I/O	PQA[7:5]
AN[56:55]/ETRIG[2:1]	Ba	Yes	Yes	I/O	PQA[4:3]
AN[54:52]/MA[2:0]	Ba	Yes	Yes	I/O	PQA[2:0]
$\overline{AS}$	B	Yes	Yes	I/O	PE5
$\overline{AVEC}$	B	Yes	No	I/O	PE2
$\overline{BERR}$	B	Yes	No	—	—
BG/CS1	B	—	—	—	—
BGACK/CS2	B	Yes	No	—	—
BKPT/DSCLK	—	Yes	Yes	—	—
BR/CS0	B	Yes	No	O	—
CLKOUT	A	—	—	—	—
CANRX0 (MC68376 Only)	—	Yes	Yes	—	—
CANTX0 (MC68376 Only)	Bo	—	—	—	—
$\overline{CSBOOT}$	B	—	—	—	—
CTD[10:9]/[4:3]	A	Yes	Yes	I/O	—
CPWM[8:5]	A	—	—	O	—
CTM2C	—	Yes	Yes	I	—
DATA[15:0]	Aw	Yes <sup>1</sup>	No	—	—
$\overline{DS}$	B	Yes	Yes	I/O	PE4
DSACK[1:0]	B	Yes	No	I/O	PE[1:0]
EXTAL <sup>2</sup>	—	—	Special	—	—
FC[2:0]/CS[5:3]	A	Yes	No	O	PC[2:0]
FREEZE/QUOT	A	—	—	—	—
$\overline{IPIPE}/DSO$	A	—	—	O	—
IFETCH/DSI	A	Yes	Yes	—	—
$\overline{HALT}$	Bo	Yes	No	—	—
$\overline{IRQ}[7:1]$	B	Yes	Yes	I/O	PF[7:1]
MISO	Bo	Yes <sup>1</sup>	Yes	I/O	PQS0
MODCLK	B	Yes <sup>1</sup>	Yes	I/O	PF0
MOSI	Bo	Yes <sup>1</sup>	Yes	I/O	PQS1
PCS0/ $\overline{SS}$	Bo	Yes <sup>1</sup>	Yes	I/O	PQS3
PCS[3:1]	Bo	Yes <sup>1</sup>	Yes	I/O	PQS[6:4]
R/ $\overline{W}$	A	Yes	No	—	—
$\overline{RESET}$	Bo	Yes	Yes	—	—
$\overline{RMC}$	B	Yes	Yes	I/O	PE3
RXD	—	No	Yes	—	—
SCK	Bo	Yes <sup>1</sup>	Yes	I/O	PQS2

**Table 3-1 MC68336/376 Pin Characteristics (Continued)**

Pin Mnemonic	Output Driver	Input Synchronized	Input Hysteresis	Discrete I/O	Port Designation
SIZ[1:0]	B	Yes	Yes	I/O	PE[7:6]
T2CLK	—	Yes	Yes	—	—
TPUCH[15:0]	A	Yes	Yes	—	—
TSTME/TSC	—	Yes	Yes	—	—
TXD	Bo	Yes <sup>1</sup>	Yes	I/O	PQS7
XFC <sup>2</sup>	—	—	—	Special	—
XTAL <sup>2</sup>	—	—	—	Special	—

NOTES:

1. DATA[15:0] are synchronized during reset only. MODCLK, and the QSM and QADC pins are synchronized only when used as input port pins.
2. EXTAL, XFC and XTAL are clock reference connections.

**Table 3-2 MC68336/376 Output Driver Types**

Type	Description
A	Output only signals that are always driven. No external pull-up required.
Ao	Type A output that can be operated in an open-drain mode.
Aw	Type A output with p-channel precharge when reset.
B	Three-state output that includes circuitry to assert output before high impedance is established, to ensure rapid rise time. An external holding resistor is required to maintain logic level while in the high-impedance state.
Bo	Type B output that can be operated in an open-drain mode.
Ba	Three-state output that can be operated in open-drain mode only.

**Table 3-3 MC68336/376 Power Connections**

Pin	Description
V <sub>STBY</sub>	Standby RAM power
V <sub>DDSYN</sub>	Clock synthesizer power
V <sub>DDA</sub> , V <sub>SSA</sub>	QADC converter power
V <sub>RH</sub> , V <sub>RL</sub>	QADC reference voltage
V <sub>SS</sub> , V <sub>DD</sub>	Microcontroller power

### 3.5 Signal Descriptions

The following tables define the MC68336/376 signals. **Table 3-4** shows signal origin, type, and active state. **Table 3-5** describes signal functions. Both tables are sorted alphabetically by mnemonic. MCU pins often have multiple functions. More than one description can apply to a pin.

**Table 3-4 MC68336/376 Signal Characteristics**

Signal Name	MCU Module	Signal Type	Active State
ADDR[23:0]	SIM	Bus	—
AN[59:48]/[3:0]	QADC	Input	—
AN[w, x, y, z]	QADC	Input	—
AS	SIM	Output	0
AVEC	SIM	Input	0
BERR	SIM	Input	0
BG	SIM	Output	0
BGACK	SIM	Input	0
BKPT	CPU32	Input	0
BR	SIM	Input	0
CLKOUT	SIM	Output	—
CANRX0 (MC68376 Only)	TouCAN	Input	—
CANTX0 (MC68376 Only)	TouCAN	Output	—
CS[10:0]	SIM	Output	0
CSBOOT	SIM	Output	0
CPWM[8:5]	CTM4	Output	—
CTD[10:9]/[4:3]	CTM4	Input/Output	—
CTM2C	CTM4	Input	—
DATA[15:0]	SIM	Bus	—
DS	SIM	Output	0
DSACK[1:0]	SIM	Input	0
DSCLK	CPU32	Input	Serial Clock
DSI	CPU32	Input	Serial Data
DSO	CPU32	Output	Serial Data
ECLK	SIM	Output	—
ETRIG[2:1]	QADC	Input	—
EXTAL	SIM	Input	—
FC[2:0]	SIM	Output	—
FREEZE	SIM	Output	1
HALT	SIM	Input/Output	0
IFETCH	CPU32	Output	0
IPIPE	CPU32	Output	0
IRQ[7:1]	SIM	Input	0
MA[2:0]	QADC	Output	1
MISO	QSM	Input/Output	—
MODCLK	SIM	Input	—
MOSI	QSM	Input/Output	—
PC[6:0]	SIM	Output	—
PCS[3:0]	QSM	Input/Output	—
PE[7:0]	SIM	Input/Output	—
PF[7:0]	SIM	Input/Output	—

**Table 3-4 MC68336/376 Signal Characteristics (Continued)**

Signal Name	MCU Module	Signal Type	Active State
PQA[7:0]	QADC	Input/Output	—
PQB[7:0]	QADC	Input	—
PQS[7:0]	QSM	Input/Output	—
QUOT	SIM	Output	—
R/W	SIM	Output	1/0
RESET	SIM	Input/Output	0
RMC	SIM	Output	0
RXD	QSM	Input	—
SCK	QSM	Input/Output	—
SIZ[1:0]	SIM	Output	1
SS	QSM	Input	0
T2CLK	TPU	Input	—
TPUCH[15:0]	TPU	Input/Output	—
TSTME/TSC	SIM	Input	0/1
TXD	QSM	Output	—
XFC	SIM	Input	—
XTAL	SIM	Output	—

**Table 3-5 MC68336/376 Signal Functions**

<b>Mnemonic</b>	<b>Signal Name</b>	<b>Function</b>
ADDR[23:0]	Address Bus	24-bit address bus used by the CPU32
AN[59:48]/[3:0]	QADC Analog Input	16 channel A/D converter analog input pins
AN[w, x, y, z]	QADC Analog Input	Four input channels utilized when operating in multiplexed mode
AS	Address Strobe	Indicates that a valid address is on the address bus
AVEC	Autovector	Requests an automatic vector during interrupt acknowledge
BERR	Bus Error	Indicates that a bus error has occurred
BG	Bus Grant	Indicates that the MCU has relinquished the bus
BGACK	Bus Grant Acknowledge	Indicates that an external device has assumed bus mastership
BKPT	Breakpoint	Signals a hardware breakpoint to the CPU
BR	Bus Request	Indicates that an external device requires bus mastership
CLKOUT	System Clock Out	System clock output
CANRX0	TouCAN Receive Data	CAN serial data input
CANTX0	TouCAN Transmit Data	CAN serial data output
CS[10:0]	Chip-Selects	Select external devices at programmed addresses
CSBOOT	Boot Chip-Select	Chip-select for external bootstrap memory
CPWM[8:5]	CTM4 PWMs	Four pulse-width modulation channels
CTD[10:9]/[4:3]	CTM4 Double Action Channels	Bidirectional double action timer channels
CTM2C	CTM4 Modulus Clock	Modulus counter clock input
DATA[15:0]	Data Bus	16-bit data bus used by the CPU32
DS	Data Strobe	Indicates that an external device should place valid data on the data bus during a read cycle and that valid data has been placed on the data bus by the CPU during a write cycle.
DSACK[1:0]	Data and Size Acknowledge	Provides asynchronous data transfers and dynamic bus sizing
DSI, DSO, DSCLK	Developmental Serial In, Out, Clock	Serial I/O and clock for background debug mode
ECLK	E-Clock	M6800 bus clock output
ETRIG[2:1]	QADC External Trigger	External trigger pins used when a QADC scan queue is in external trigger mode
EXTAL, XTAL	Crystal Oscillator	Connections for clock synthesizer circuit reference; a crystal or an external oscillator can be used
FC[2:0]	Function Codes	Identify processor state and current address space
FREEZE	Freeze	Indicates that the CPU has acknowledged a breakpoint
HALT	Halt	Suspend external bus activity
IFETCH	Instruction Pipeline	Indicates instruction pipeline activity
IPIPE	Instruction Pipeline	Indicates instruction pipeline activity
IRQ[7:1]	Interrupt Request	Requests an interrupt of specified priority level from the CPU
MA[2:0]	QADC Multiplexed Address	When external multiplexing is used, these pins provide addresses to the external multiplexer
MISO	Master In, Slave Out	Serial input to QSPI in the master mode; serial output from QSPI in the slave mode
MODCLK	Clock Mode Select	Selects the source of the system clock
MOSI	Master Out, Slave In	Serial output from the QSPI in master mode; serial input to the QSPI in slave mode
PC[6:0]	Port C	SIM digital output port signals
PCS[3:0]	Peripheral Chip-Selects	QSPI peripheral chip-select
PE[7:0]	Port E	SIM digital input/output port signals
PF[7:0]	Port F	SIM digital input/output port signals

**Table 3-5 MC68336/376 Signal Functions (Continued)**

<b>Mnemonic</b>	<b>Signal Name</b>	<b>Function</b>
PQA[7:0]	QADC Port A	QADC port A digital input/output port signals
PQB[7:0]	QADC Port B	QADC port B digital input port signals
PQS[7:0]	Port QS	QSM digital input/output port signals
QUOT	Quotient Out	Provides the quotient bit of the polynomial divider (test mode only)
R/W	Read/Write	Indicates the direction of data transfer on the bus
RESET	Reset	System reset
RMC	Read-Modify-Write Cycle	Indicates an indivisible read-modify-write instruction
RXD	SCI Receive Data	Serial input to the SCI
SCK	QSPI Serial Clock	Clock output from QSPI in master mode; clock input to QSPI in slave mode
SIZ[1:0]	Size	Indicates the number of bytes remaining to be transferred during a bus cycle
SS	Slave Select	Starts serial transmission when QSPI is in slave mode; chip-select in master mode
T2CLK	TPU Clock	TPU clock input
TPUCH[15:0]	TPU I/O Channels	Bidirectional TPU channels
TSC	Three-State Control	Places all output drivers in a high impedance state
TSTME	Test Mode Enable	Hardware enable for SIM test mode
TXD	SCI Transmit Data	Serial output from the SCI
XFC	External Filter Capacitor	Connection for external phase-locked loop filter capacitor

### 3.6 Internal Register Map

In **Figure 3-4**, IMB ADDR[23:20] are represented by the letter Y. The value represented by Y determines the base address of MCU module control registers. In the MC68336/376, Y is equal to M111, where M is the logic state of the module mapping (MM) bit in the system integration module configuration register (SIMCR).

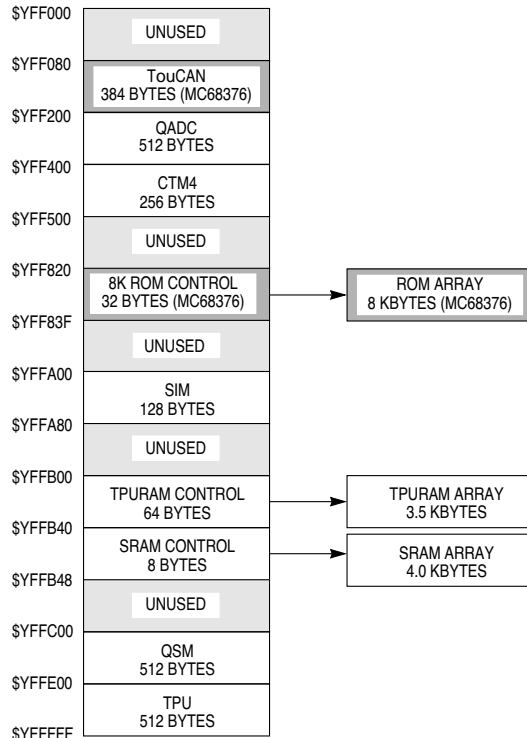

- NOTES: 1. Y=M111, WHERE M IS THE MODMAP SIGNAL STATE ON THE IMB, WHICH REFLECTS THE STATE OF THE MODMAP IN THE MODULE CONFIGURATION REGISTER OF THE SYSTEM INTEGRATION MODULE. (Y=\$7 OR \$F)
2. ATTEMPTED ACCESSES TO UNUSED LOCATIONS OR UNUSED BITS WITHIN VALID LOCATIONS RETURN ALL ZEROS.

336/376 ADDRESS MAP

**Figure 3-4 MC68336/376 Address Map**

### 3.7 Address Space Maps

**Figure 3-5** shows a single memory space. Function codes FC[2:0] are not decoded externally so that separate user/supervisor or program/data spaces are not provided. In **Figure 3-6**, FC2 is decoded, resulting in separate supervisor and user spaces. FC[1:0] are not decoded, so that separate program and data spaces are not provided. In **Figures 3-7** and **3-8**, FC[2:0] are decoded, resulting in four separate memory spaces: supervisor/program, supervisor/data, user/program and user/data.

All exception vectors are located in supervisor data space, except the reset vector, which is located in supervisor program space. Only the initial reset vector is fixed in the processor's memory map. Once initialization is complete, there are no fixed assignments. Since the vector base register (VBR) provides the base address of the vector table, the vector table can be located anywhere in memory. Refer to **SECTION 4 CENTRAL PROCESSOR UNIT** for more information concerning memory management, extended addressing, and exception processing. Refer to **5.5.1.7 Function Codes** for more information concerning function codes and address space types.



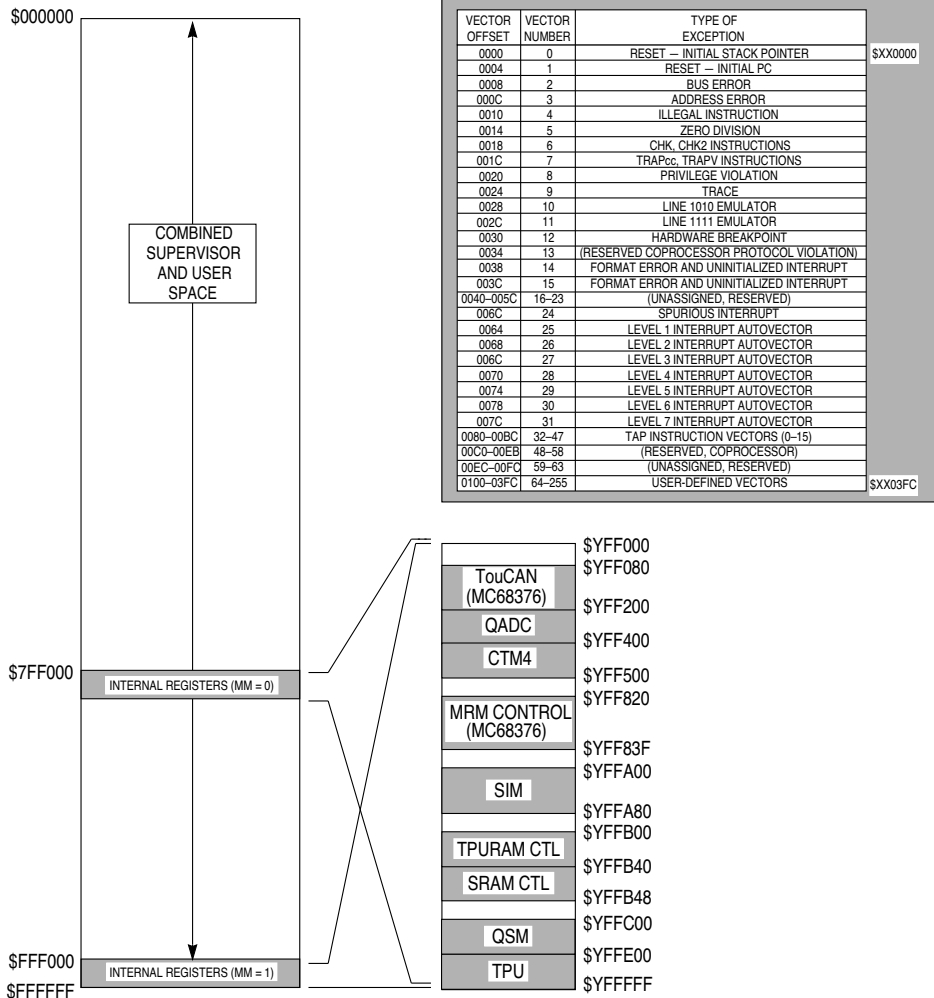

**NOTES:**

1. LOCATION OF THE EXCEPTION VECTOR TABLE IS DETERMINED BY THE VECTOR BASE REGISTER. THE VECTOR ADDRESS IS THE CONCATENATION OF THE UPPER 22 BITS OF THE VBR WITH THE 8-BIT VECTOR NUMBER OF THE INTERRUPTING MODULE. THE RESULT IS LEFT JUSTIFIED TO FORCE LONG WORD ALIGNMENT.
2. LOCATION OF THE MODULE CONTROL REGISTERS IS DETERMINED BY THE STATE OF THE MODULE MAPPING (MM) BIT IN THE SIM CONFIGURATION REGISTER. Y = M111 WHERE M IS THE STATE OF THE MM BIT.
3. SOME UNUSED ADDRESSES WITHIN THE INTERNAL REGISTER BLOCK ARE MAPPED EXTERNALLY. REFER TO THE APPROPRIATE MODULE REFERENCE MANUAL FOR INFORMATION ON MAPPING OF UNUSED ADDRESSES WITHIN INTERNAL REGISTER BLOCKS.

336/376 S/U COMB MAP

**Figure 3-5 Overall Memory Map**

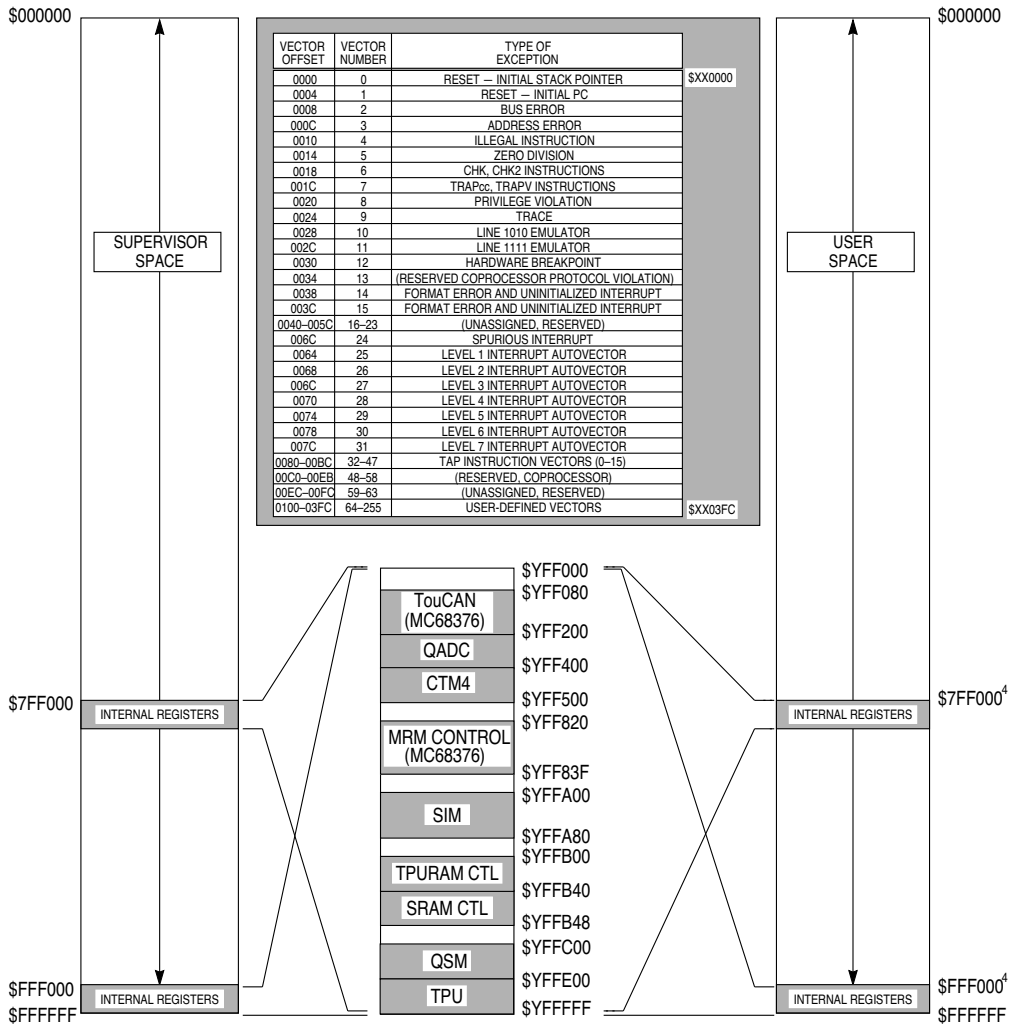

NOTES:

1. LOCATION OF THE EXCEPTION VECTOR TABLE IS DETERMINED BY THE VECTOR BASE REGISTER. THE VECTOR ADDRESS IS THE CONCATENATION OF THE UPPER 22 BITS OF THE VBR WITH THE 8-BIT VECTOR NUMBER OF THE INTERRUPTING MODULE. THE RESULT IS LEFT JUSTIFIED TO FORCE LONG WORD ALIGNMENT.
2. LOCATION OF THE MODULE CONTROL REGISTERS IS DETERMINED BY THE STATE OF THE MODULE MAPPING (MM) BIT IN THE SIM CONFIGURATION REGISTER. Y = M111 WHERE M IS THE STATE OF THE MM BIT.
3. SOME UNUSED ADDRESSES WITHIN THE INTERNAL REGISTER BLOCK ARE MAPPED EXTERNALLY. REFER TO THE APPROPRIATE MODULE REFERENCE MANUAL FOR INFORMATION ON MAPPING OF UNUSED ADDRESSES WITHIN INTERNAL REGISTER BLOCKS.
4. SOME INTERNAL REGISTERS ARE NOT AVAILABLE IN USER SPACE.

336/376 S/U SEP MAP

Figure 3-6 Separate Supervisor and User Space Map

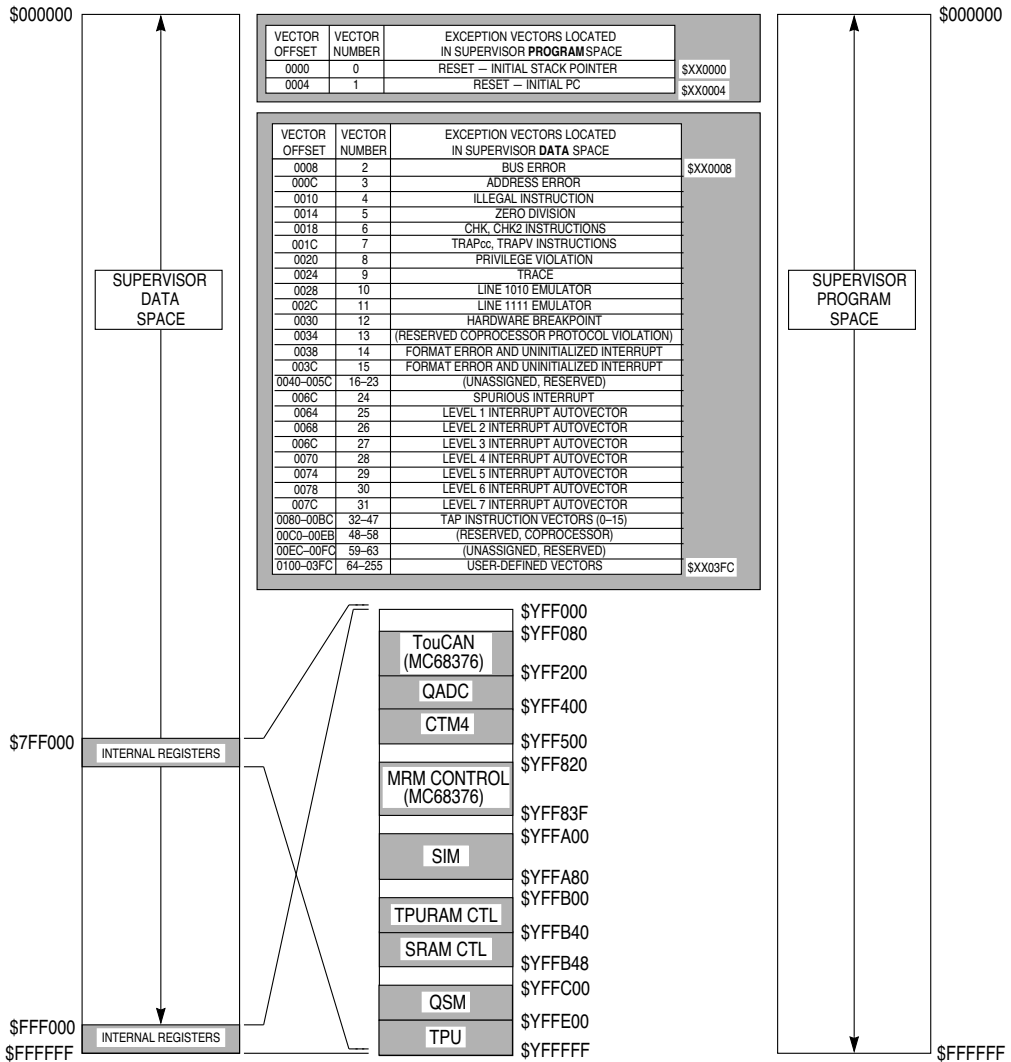

**NOTES:**

1. LOCATION OF THE EXCEPTION VECTOR TABLE IS DETERMINED BY THE VECTOR BASE REGISTER. THE VECTOR ADDRESS IS THE CONCATENATION OF THE UPPER 22 BITS OF THE VBR WITH THE 8-BIT VECTOR NUMBER OF THE INTERRUPTING MODULE. THE RESULT IS LEFT JUSTIFIED TO FORCE LONG WORD ALIGNMENT.
2. LOCATION OF THE MODULE CONTROL REGISTERS IS DETERMINED BY THE STATE OF THE MODULE MAPPING (MM) BIT IN THE SIM CONFIGURATION REGISTER. Y = M111 WHERE M IS THE STATE OF THE MM BIT.
3. SOME UNUSED ADDRESSES WITHIN THE INTERNAL REGISTER BLOCK ARE MAPPED EXTERNALLY. REFER TO THE APPROPRIATE MODULE REFERENCE MANUAL FOR INFORMATION ON MAPPING OF UNUSED ADDRESSES WITHIN INTERNAL REGISTER BLOCKS.
4. SOME INTERNAL REGISTERS ARE NOT AVAILABLE IN USER SPACE.

336/376 SUPER P/D MAP

**Figure 3-7 Supervisor Space (Separate Program/Data Space) Map**

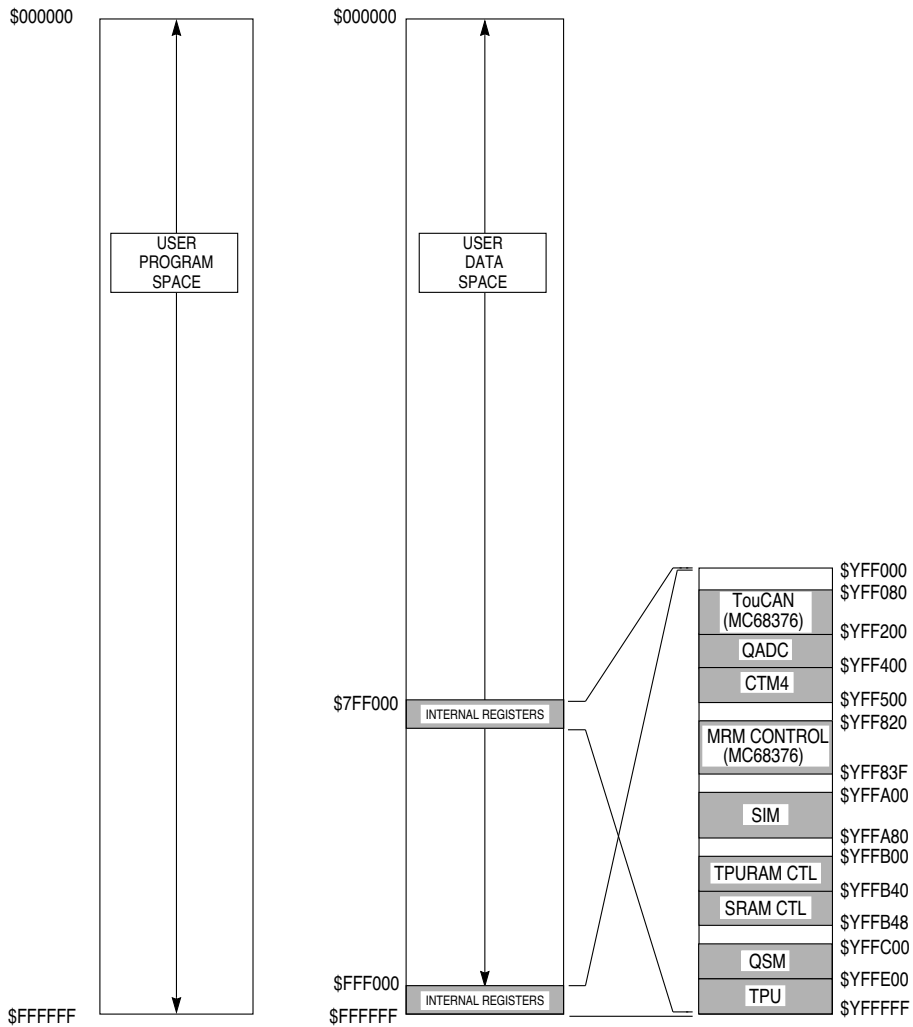

NOTES:

1. LOCATION OF THE MODULE CONTROL REGISTERS IS DETERMINED BY THE STATE OF THE MODULE MAPPING (MM) BIT IN THE SIM CONFIGURATION REGISTER. Y = M111, WHERE M IS THE STATE OF THE MM BIT.
2. UNUSED ADDRESSES WITHIN THE INTERNAL REGISTER BLOCK ARE MAPPED EXTERNALLY. "RESERVED" BLOCKS ARE NOT MAPPED EXTERNALLY.
3. SOME INTERNAL REGISTERS ARE NOT AVAILABLE IN USER SPACE.

386/376 USER P/D MAP

**Figure 3-8 User Space (Separate Program/Data Space) Map**

## SECTION 4 CENTRAL PROCESSOR UNIT

The CPU32, the instruction processing module of the M68300 family, is based on the industry-standard MC68000 processor. It has many features of the MC68010 and MC68020, as well as unique features suited for high-performance controller applications. This section is an overview of the CPU32. For detailed information concerning CPU operation, refer to the *CPU32 Reference Manual* (CPU32RM/AD).

### 4.1 General

Ease of programming is an important consideration in using a microcontroller. The CPU32 instruction format reflects a philosophy emphasizing register-memory interaction. There are eight multifunction data registers and seven general-purpose addressing registers.

All data resources are available to all operations requiring those resources. The data registers readily support 8-bit (byte), 16-bit (word), and 32-bit (long-word) operand lengths for all operations. Word and long-word operations support address manipulation. Although the program counter (PC) and stack pointers (SP) are special-purpose registers, they are also available for most data addressing activities. Ease of program checking and diagnosis is further enhanced by trace and trap capabilities at the instruction level.

A block diagram of the CPU32 is shown in **Figure 4-1**. The major blocks operate in a highly independent fashion that maximizes concurrency of operation while managing the essential synchronization of instruction execution and bus operation. The bus controller loads instructions from the data bus into the decode unit. The sequencer and control unit provide overall chip control, managing the internal buses, registers, and functions of the execution unit.

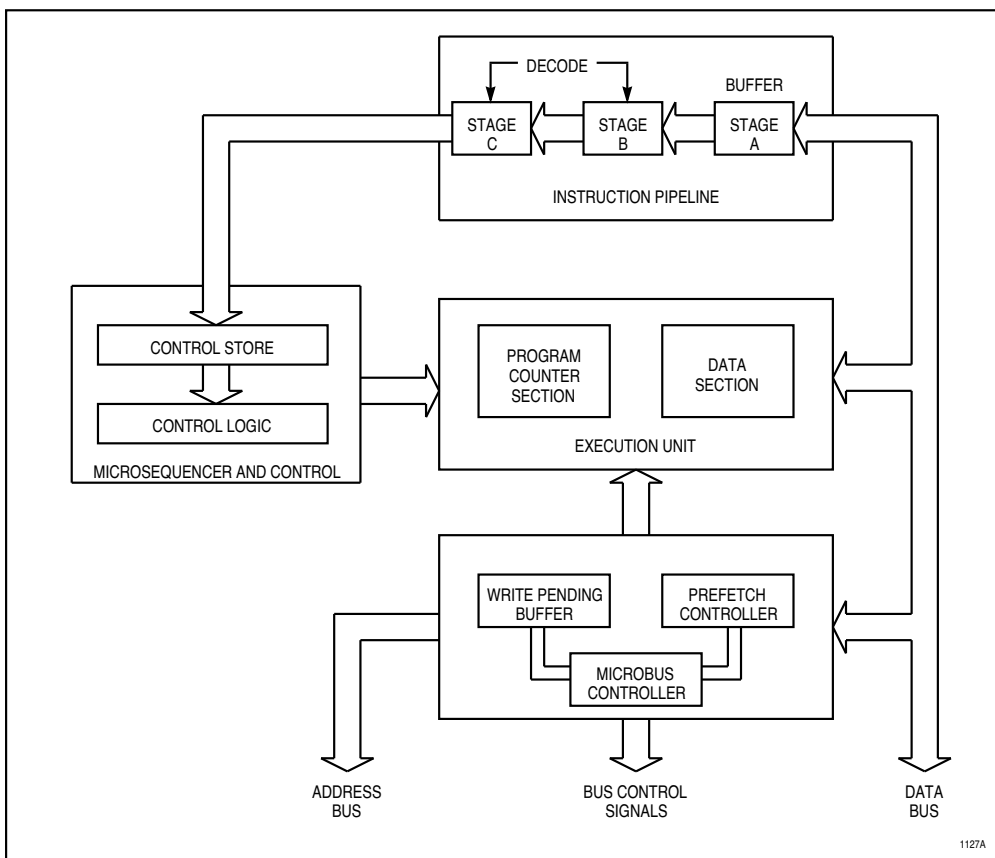
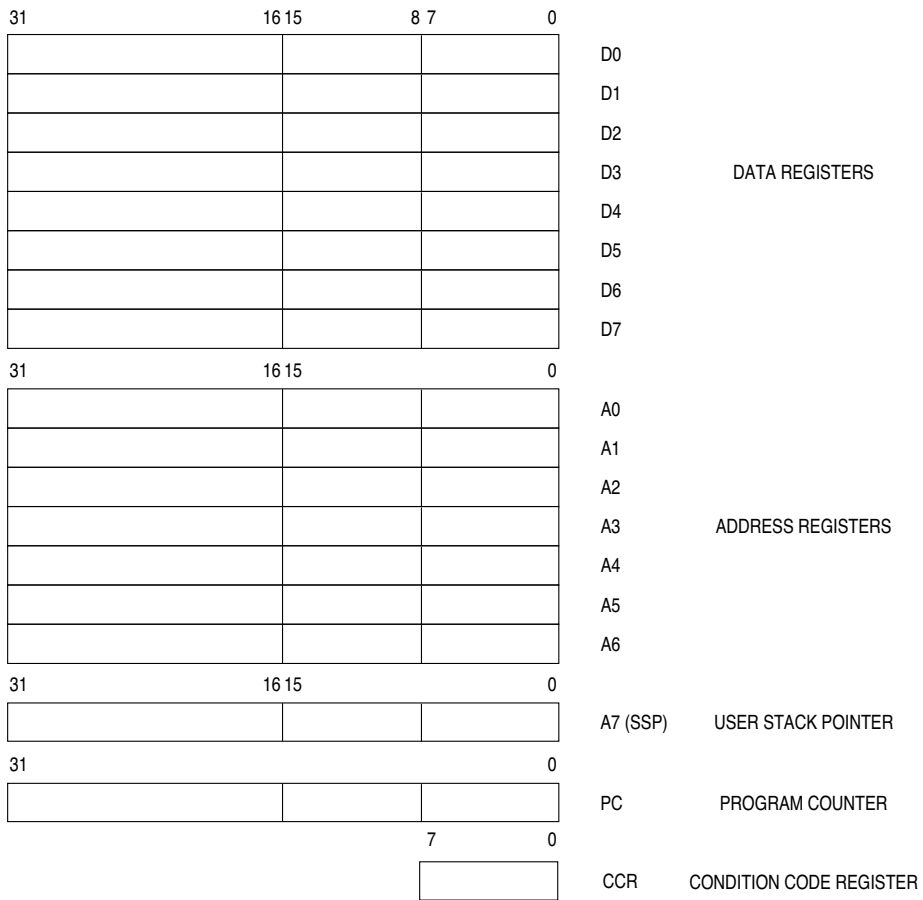

**Figure 4-1 CPU32 Block Diagram**

## 4.2 CPU32 Registers

The CPU32 programming model consists of two groups of registers that correspond to the user and supervisor privilege levels. User programs can use only the registers of the user model. The supervisor programming model, which supplements the user programming model, is used by CPU32 system programmers who wish to protect sensitive operating system functions. The supervisor model is identical to that of the MC68010 and later processors.

The CPU32 has eight 32-bit data registers, seven 32-bit address registers, a 32-bit program counter, separate 32-bit supervisor and user stack pointers, a 16-bit status register, two alternate function code registers, and a 32-bit vector base register. Refer to **Figures 4-2** and **4-3**.



CPU32 USER PROG MODEL

**Figure 4-2 User Programming Model**

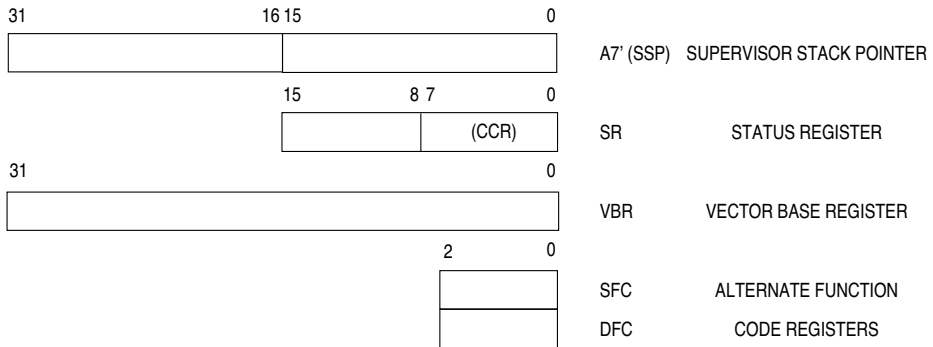

CPU32 SUPV PROG MODEL

**Figure 4-3 Supervisor Programming Model Supplement**

### 4.2.1 Data Registers

The eight data registers can store data operands of 1, 8, 16, 32, and 64 bits and addresses of 16 or 32 bits. The following data types are supported:

- Bits
- Packed Binary-Coded Decimal Digits
- Byte Integers (8 bits)
- Word Integers (16 bits)
- Long-Word Integers (32 bits)
- Quad-Word Integers (64 bits)

Each of data registers D7–D0 is 32 bits wide. Byte operands occupy the low-order 8 bits; word operands, the low-order 16 bits; and long-word operands, the entire 32 bits. When a data register is used as either a source or destination operand, only the appropriate low-order byte or word (in byte or word operations, respectively) is used or changed; the remaining high-order portion is unaffected. The least significant bit (LSB) of a long-word integer is addressed as bit zero, and the most significant bit (MSB) is addressed as bit 31. **Figure 4-4** shows the organization of various types of data in the data registers.

Quad-word data consists of two long words and represents the product of 32-bit multiply or the dividend of 32-bit divide operations (signed and unsigned). Quad-words may be organized in any two data registers without restrictions on order or pairing. There are no explicit instructions for the management of this data type, although the MOVEM instruction can be used to move a quad-word into or out of the registers.

Binary-coded decimal (BCD) data represents decimal numbers in binary form. CPU32 BCD instructions use a format in which a byte contains two digits. The four LSB contain the least significant digit, and the four MSB contain the most significant digit. The ABCD, SBCD, and NBCD instructions operate on two BCD digits packed into a single byte.



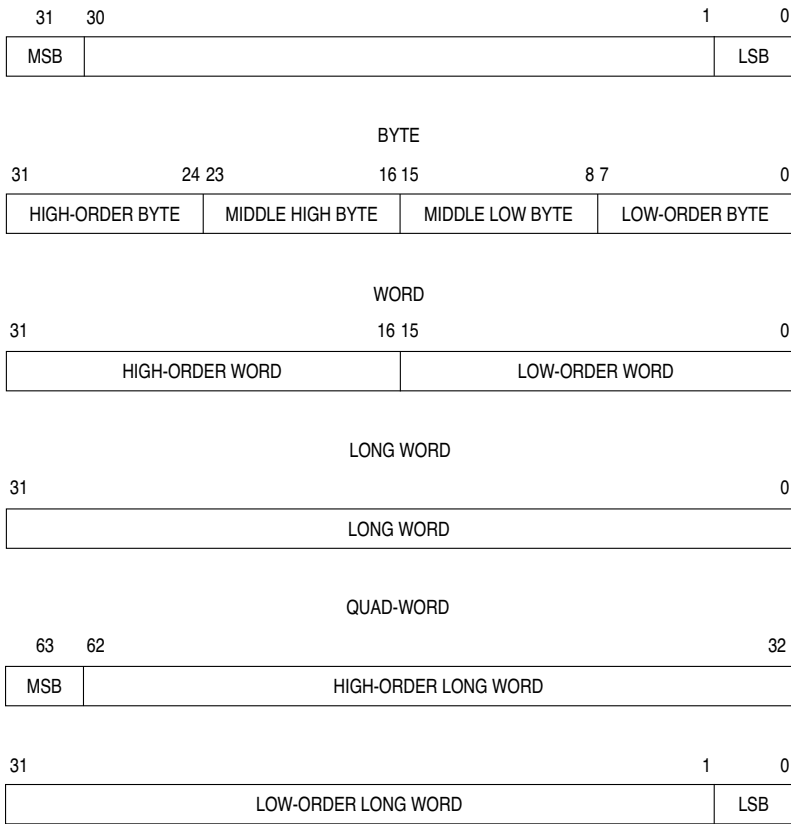

CPU32 DATA ORG

**Figure 4-4 Data Organization in Data Registers**

### 4.2.2 Address Registers

Each address register and stack pointer is 32 bits wide and holds a 32-bit address. Address registers cannot be used for byte-sized operands. Therefore, when an address register is used as a source operand, either the low-order word or the entire long-word operand is used, depending upon the operation size. When an address register is used as the destination operand, the entire register is affected, regardless of the operation size. If the source operand is a word size, it is sign-extended to 32 bits. Address registers are used primarily for addresses and to support address computation. The instruction set includes instructions that add to, subtract from, compare, and move the contents of address registers. **Figure 4-5** shows the organization of addresses in address registers.

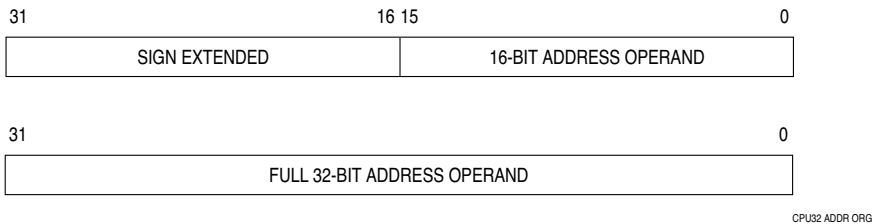

**Figure 4-5 Address Organization in Address Registers**

### 4.2.3 Program Counter

The PC contains the address of the next instruction to be executed by the CPU32. During instruction execution and exception processing, the processor automatically increments the contents of the PC or places a new value in the PC as appropriate.

### 4.2.4 Control Registers

The control registers described in this section contain control information for supervisor functions and vary in size. With the exception of the condition code register (the user portion of the status register), they are accessed only by instructions at the supervisor privilege level.

#### 4.2.4.1 Status Register

The status register (SR) stores the processor status. It contains the condition codes that reflect the results of a previous operation and can be used for conditional instruction execution in a program. The condition codes are extend (X), negative (N), zero (Z), overflow (V), and carry (C). The user (low-order) byte containing the condition codes is the only portion of the SR information available at the user privilege level; it is referenced as the condition code register (CCR) in user programs.

At the supervisor privilege level, software can access the full status register. The upper byte of this register includes the interrupt priority (IP) mask (three bits), two bits for placing the processor in one of two tracing modes or disabling tracing, and the supervisor/user bit for placing the processor at the desired privilege level.

Undefined bits in the status register are reserved by Motorola for future definition. The undefined bits are read as zeros and should be written as zeros for future compatibility.

All operations to the SR and CCR are word-size operations, but for all CCR operations, the upper byte is read as all zeros and is ignored when written, regardless of privilege level.

Refer to **D.1.2 Status Register** for bit/field definitions and a diagram of the status register.

#### 4.2.4.2 Alternate Function Code Registers

Alternate function code registers (SFC and DFC) contain 3-bit function codes. Function codes can be considered extensions of the 24-bit linear address that optionally provide as many as eight 16-Mbyte address spaces. The processor automatically generates function codes to select address spaces for data and programs at the user and supervisor privilege levels and to select a CPU address space used for processor functions (such as breakpoint and interrupt acknowledge cycles).

Registers SFC and DFC are used by the MOVES instruction to specify explicitly the function codes of the memory address. The MOVEC instruction is used to transfer values to and from the alternate function code registers. This is a long-word transfer; the upper 29 bits are read as zeros and are ignored when written.

#### 4.2.5 Vector Base Register (VBR)

The VBR contains the base address of the 1024-byte exception vector table, consisting of 256 exception vectors. Exception vectors contain the memory addresses of routines that begin execution at the completion of exception processing. More information on the VBR and exception processing can be found in **4.9 Exception Processing**.

### 4.3 Memory Organization

Memory is organized on a byte-addressable basis in which lower addresses correspond to higher order bytes. For example, the address  $N$  of a long-word data item corresponds to the address of the most significant byte of the highest order word. The address of the most significant byte of the low-order word is  $N + 2$ , and the address of the least significant byte of the long word is  $N + 3$ . The CPU32 requires long-word and word data and all instructions to be aligned on word boundaries. Refer to **Figure 4-6**. If this does not happen, an exception will occur when the CPU32 accesses the misaligned instruction or data. Data misalignment is not supported.

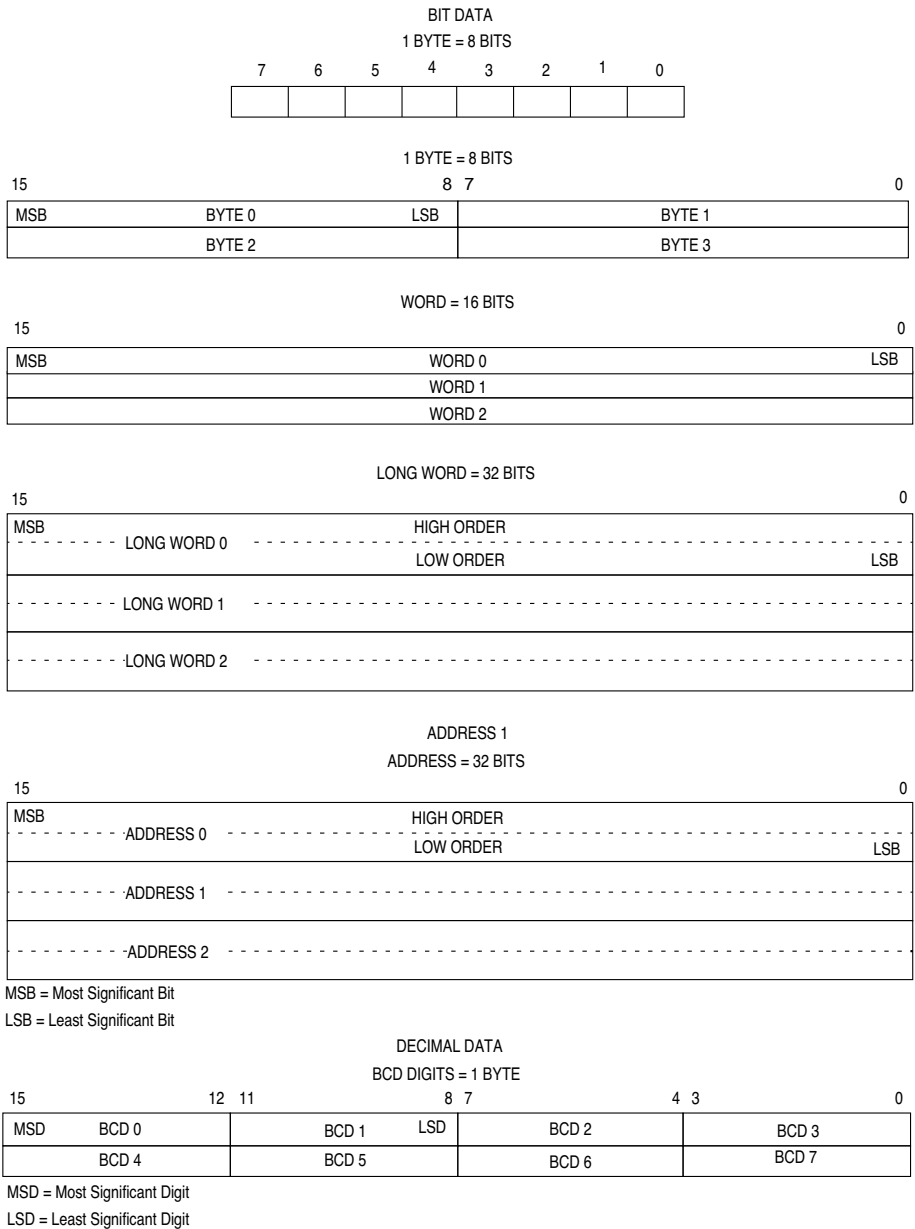

1125A

**Figure 4-6 Memory Operand Addressing**

## 4.4 Virtual Memory

The full addressing range of the CPU32 on the MC68336/376 is 16 Mbytes in each of eight address spaces. Even though most systems implement a smaller physical memory, the system can be made to appear to have a full 16 Mbytes of memory available to each user program by using virtual memory techniques.

A system that supports virtual memory has a limited amount of high-speed physical memory that can be accessed directly by the processor and maintains an image of a much larger virtual memory on a secondary storage device. When the processor attempts to access a location in the virtual memory map that is not resident in physical memory, a page fault occurs. The access to that location is temporarily suspended while the necessary data is fetched from secondary storage and placed in physical memory. The suspended access is then restarted or continued.

The CPU32 uses instruction restart, which requires that only a small portion of the internal machine state be saved. After correcting the fault, the machine state is restored, and the instruction is fetched and started again. This process is completely transparent to the application program.

## 4.5 Addressing Modes

Addressing in the CPU32 is register-oriented. Most instructions allow the results of the specified operation to be placed either in a register or directly in memory. There is no need for extra instructions to store register contents in memory.

There are seven basic addressing modes:

- Register Direct
- Register Indirect
- Register Indirect with Index
- Program Counter Indirect with Displacement
- Program Counter Indirect with Index
- Absolute
- Immediate

The register indirect addressing modes include postincrement, predecrement, and offset capability. The program counter indirect mode also has index and offset capabilities. In addition to these addressing modes, many instructions implicitly specify the use of the status register, stack pointer, and/or program counter.

## 4.6 Processing States

The processor is always in one of four processing states: normal, exception, halted, or background. The normal processing state is associated with instruction execution; the bus is used to fetch instructions and operands and to store results.

The exception processing state is associated with interrupts, trap instructions, tracing, and other exception conditions. The exception may be internally generated explicitly by an instruction or by an unusual condition arising during the execution of an instruction. Exception processing can be forced externally by an interrupt, a bus error, or a reset.

The halted processing state is an indication of catastrophic hardware failure. For example, if during the exception processing of a bus error another bus error occurs, the processor assumes that the system is unusable and halts.

The background processing state is initiated by breakpoints, execution of special instructions, or a double bus fault. Background processing is enabled by pulling BKPT low during RESET. Background processing allows interactive debugging of the system via a simple serial interface.

#### 4.7 Privilege Levels

The processor operates at one of two levels of privilege: user or supervisor. Not all instructions are permitted to execute at the user level, but all instructions are available at the supervisor level. Effective use of privilege level can protect system resources from uncontrolled access. The state of the S bit in the status register determines the privilege level and whether the user stack pointer (USP) or supervisor stack pointer (SSP) is used for stack operations.

#### 4.8 Instructions

The CPU32 instruction set is summarized in **Table 4-2**. The instruction set of the CPU32 is very similar to that of the MC68020. Two new instructions have been added to facilitate controller applications: low-power stop (LPSTOP) and table lookup and interpolate (TBLS, TBLSN, TBLU, TBLUN).

**Table 4-1** shows the MC68020 instructions that are not implemented on the CPU32.

**Table 4-1 Unimplemented MC68020 Instructions**

BFxx	—	Bit Field Instructions (BFCHG, BFCLR, BFEXTS, BFEXTU, BFFFO, BFINS, BFSET, BFTST)
CALLM, RTM	—	Call Module, Return Module
CAS, CAS2	—	Compare and Swap (Read-Modify-Write Instructions)
cpxxx	—	Coprocessor Instructions (cpBcc, cpDBcc, cpGEN)
PACK, UNPK	—	Pack, Unpack BCD Instructions
Memory	—	Memory Indirect Addressing Modes

The CPU32 traps on unimplemented instructions or illegal effective addressing modes, allowing user-supplied code to emulate unimplemented capabilities or to define special purpose functions. However, Motorola reserves the right to use all currently unimplemented instruction operation codes for future M68000 core enhancements.

**Table 4-2 Instruction Set Summary**

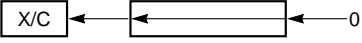
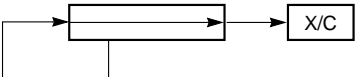
ABCD	Dn, Dn – (An), – (An)	8 8	Source <sub>10</sub> + Destination <sub>10</sub> + X ⇒ Destination
ADD	Dn, <ea> <ea>, Dn	8, 16, 32 8, 16, 32	Source + Destination ⇒ Destination
ADDA	<ea>, An	16, 32	Source + Destination ⇒ Destination
ADDI	#<data>, <ea>	8, 16, 32	Immediate data + Destination ⇒ Destination
ADDQ	#<data>, <ea>	8, 16, 32	Immediate data + Destination ⇒ Destination
ADDX	Dn, Dn – (An), – (An)	8, 16, 32 8, 16, 32	Source + Destination + X ⇒ Destination
AND	<ea>, Dn Dn, <ea>	8, 16, 32 8, 16, 32	Source • Destination ⇒ Destination
ANDI	#<data>, <ea>	8, 16, 32	Data • Destination ⇒ Destination
ANDI to CCR	#<data>, CCR	8	Source • CCR ⇒ CCR
ANDI to SR1 <sup>†</sup>	#<data>, SR	16	Source • SR ⇒ SR
ASL	Dn, Dn #<data>, Dn <ea>	8, 16, 32 8, 16, 32 16	
ASR	Dn, Dn #<data>, Dn <ea>	8, 16, 32 8, 16, 32 16	
Bcc	label	8, 16, 32	If condition true, then PC + d ⇒ PC
BCHG	Dn, <ea> #<data>, <ea>	8, 32 8, 32	$\overline{((\text{bit number}) \text{ of destination})} \Rightarrow Z \Rightarrow \text{bit of destination}$
BCLR	Dn, <ea> #<data>, <ea>	8, 32 8, 32	$\overline{((\text{bit number}) \text{ of destination})} \Rightarrow Z$ ; 0 ⇒ bit of destination
BGND	none	none	If background mode enabled, then enter background mode, else format/vector ⇒ – (SSP); PC ⇒ – (SSP); SR ⇒ – (SSP); (vector) ⇒ PC
BKPT	#<data>	none	If breakpoint cycle acknowledged, then execute returned operation word, else trap as illegal instruction
BRA	label	8, 16, 32	PC + d ⇒ PC
BSET	Dn, <ea> #<data>, <ea>	8, 32 8, 32	$\overline{((\text{bit number}) \text{ of destination})} \Rightarrow Z$ ; 1 ⇒ bit of destination
BSR	label	8, 16, 32	SP – 4 ⇒ SP; PC ⇒ (SP); PC + d ⇒ PC
BTST	Dn, <ea> #<data>, <ea>	8, 32 8, 32	$\overline{((\text{bit number}) \text{ of destination})} \Rightarrow Z$
CHK	<ea>, Dn	16, 32	If Dn < 0 or Dn > (ea), then CHK exception
CHK2	<ea>, Rn	8, 16, 32	If Rn < lower bound or Rn > upper bound, then CHK exception
CLR	<ea>	8, 16, 32	0 ⇒ Destination
CMP	<ea>, Dn	8, 16, 32	(Destination – Source), CCR shows results
CMPA	<ea>, An	16, 32	(Destination – Source), CCR shows results
CMPI	#<data>, <ea>	8, 16, 32	(Destination – Data), CCR shows results
CMPM	(An) +, (An) +	8, 16, 32	(Destination – Source), CCR shows results
CMP2	<ea>, Rn	8, 16, 32	Lower bound ≤ Rn ≤ Upper bound, CCR shows result
DBcc	Dn, label	16	If condition false, then Dn – 1 ⇒ PC; if Dn ≠ (– 1), then PC + d ⇒ PC
DIVS/DIVU	<ea>, Dn	32/16 ⇒ 16 : 16	Destination / Source ⇒ Destination (signed or unsigned)

**Table 4-2 Instruction Set Summary (Continued)**

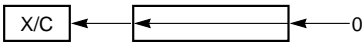
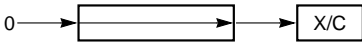
DIVSL/DIVUL	<ea>, Dr : Dq <ea>, Dq <ea>, Dr : Dq	64/32 ⇒ 32 : 32 32/32 ⇒ 32 32/32 ⇒ 32 : 32	Destination / Source ⇒ Destination (signed or unsigned)
EOR	Dn, <ea>	8, 16, 32	Source ⊕ Destination ⇒ Destination
EORI	# <data>, <ea>	8, 16, 32	Data ⊕ Destination ⇒ Destination
EORI to CCR	# <data>, CCR	8	Source ⊕ CCR ⇒ CCR
EORI to SR <sup>1</sup>	# <data>, SR	16	Source ⊕ SR ⇒ SR
EXG	Rn, Rn	32	Rn ⇒ Rn
EXT	Dn Dn	8 ⇒ 16 16 ⇒ 32	Sign extended Destination ⇒ Destination
EXTB	Dn	8 ⇒ 32	Sign extended Destination ⇒ Destination
ILLEGAL	none	none	SSP - 2 ⇒ SSP; vector offset ⇒ (SSP); SSP - 4 ⇒ SSP; PC ⇒ (SSP); SSP - 2 ⇒ SSP; SR ⇒ (SSP); Illegal instruction vector address ⇒ PC
JMP	<ea>	none	Destination ⇒ PC
JSR	<ea>	none	SP - 4 ⇒ SP; PC ⇒ (SP); destination ⇒ PC
LEA	<ea>, An	32	<ea> ⇒ An
LINK	An, # d	16, 32	SP - 4 ⇒ SP, An ⇒ (SP); SP ⇒ An, SP + d ⇒ SP
LPSTOP <sup>1</sup>	# <data>	16	Data ⇒ SR; interrupt mask ⇒ EBI; STOP
LSL	Dn, Dn # <data>, Dn <ea>	8, 16, 32 8, 16, 32 16	
LSR	Dn, Dn # <data>, Dn <ea>	8, 16, 32 8, 16, 32 16	
MOVE	<ea>, <ea>	8, 16, 32	Source ⇒ Destination
MOVEA	<ea>, An	16, 32 ⇒ 32	Source ⇒ Destination
MOVEA <sup>1</sup>	USP, An An, USP	32 32	USP ⇒ An An ⇒ USP
MOVE from CCR	CCR, <ea>	16	CCR ⇒ Destination
MOVE to CCR	<ea>, CCR	16	Source ⇒ CCR
MOVE from SR <sup>1</sup>	SR, <ea>	16	SR ⇒ Destination
MOVE to SR <sup>1</sup>	<ea>, SR	16	Source ⇒ SR
MOVE USP <sup>1</sup>	USP, An An, USP	32 32	USP ⇒ An An ⇒ USP
MOVEC <sup>1</sup>	Rc, Rn Rn, Rc	32 32	Rc ⇒ Rn Rn ⇒ Rc
MOVEM	list, <ea> <ea>, list	16, 32 16, 32 ⇒ 32	Listed registers ⇒ Destination Source ⇒ Listed registers
MOVEP	Dn, (d16, An)  (d16, An), Dn	  16, 32	Dn [31 : 24] ⇒ (An + d); Dn [23 : 16] ⇒ (An + d + 2); Dn [15 : 8] ⇒ (An + d + 4); Dn [7 : 0] ⇒ (An + d + 6)  (An + d) ⇒ Dn [31 : 24]; (An + d + 2) ⇒ Dn [23 : 16]; (An + d + 4) ⇒ Dn [15 : 8]; (An + d + 6) ⇒ Dn [7 : 0]
MOVEQ	# <data>, Dn	8 ⇒ 32	Immediate data ⇒ Destination
MOVES <sup>1</sup>	Rn, <ea> <ea>, Rn	8, 16, 32	Rn ⇒ Destination using DFC Source using SFC ⇒ Rn
MULS/MULU	<ea>, Dn <ea>, DI <ea>, Dh : DI	16 * 16 ⇒ 32 32 * 32 ⇒ 32 32 * 32 ⇒ 64	Source * Destination ⇒ Destination (signed or unsigned)
NBCD	<ea>	8 8	0 - Destination <sub>10</sub> - X ⇒ Destination

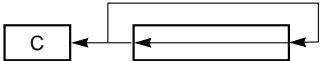
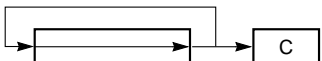
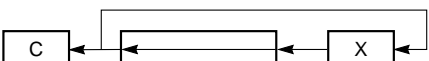
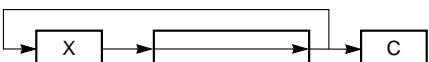
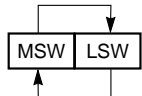

**Table 4-2 Instruction Set Summary (Continued)**

NEG	<ea>	8, 16, 32	0 – Destination $\Rightarrow$ Destination
NEGX	<ea>	8, 16, 32	0 – Destination – X $\Rightarrow$ Destination
NOP	none	none	PC + 2 $\Rightarrow$ PC
NOT	<ea>	8, 16, 32	Destination $\Rightarrow$ Destination
OR	<ea>, Dn Dn, <ea>	8, 16, 32 8, 16, 32	Source + Destination $\Rightarrow$ Destination
ORI	#<data>, <ea>	8, 16, 32	Data + Destination $\Rightarrow$ Destination
ORI to CCR	#<data>, CCR	16	Source + CCR $\Rightarrow$ SR
ORI to SR <sup>1</sup>	#<data>, SR	16	Source ; SR $\Rightarrow$ SR
PEA	<ea>	32	SP – 4 $\Rightarrow$ SP; <ea> $\Rightarrow$ SP
RESET <sup>1</sup>	none	none	Assert $\overline{\text{RESET}}$ line
ROL	Dn, Dn #<data>, Dn <ea>	8, 16, 32 8, 16, 32 16	
ROR	Dn, Dn #<data>, Dn <ea>	8, 16, 32 8, 16, 32 16	
ROXL	Dn, Dn #<data>, Dn <ea>	8, 16, 32 8, 16, 32 16	
ROXR	Dn, Dn #<data>, Dn <ea>	8, 16, 32 8, 16, 32 16	
RTD	#d	16	(SP) $\Rightarrow$ PC; SP + 4 + d $\Rightarrow$ SP
RTE <sup>1</sup>	none	none	(SP) $\Rightarrow$ SR; SP + 2 $\Rightarrow$ SP; (SP) $\Rightarrow$ PC; SP + 4 $\Rightarrow$ SP; Restore stack according to format
RTR	none	none	(SP) $\Rightarrow$ CCR; SP + 2 $\Rightarrow$ SP; (SP) $\Rightarrow$ PC; SP + 4 $\Rightarrow$ SP
RTS	none	none	(SP) $\Rightarrow$ PC; SP + 4 $\Rightarrow$ SP
SBCD	Dn, Dn – (An), – (An)	8 8	Destination <sub>10</sub> – Source <sub>10</sub> – X $\Rightarrow$ Destination
Scc	<ea>	8	If condition true, then destination bits are set to one; else, destination bits are cleared to zero
STOP <sup>1</sup>	#<data>	16	Data $\Rightarrow$ SR; STOP
SUB	<ea>, Dn Dn, <ea>	8, 16, 32	Destination – Source $\Rightarrow$ Destination
SUBA	<ea>, An	16, 32	Destination – Source $\Rightarrow$ Destination
SUBI	#<data>, <ea>	8, 16, 32	Destination – Data $\Rightarrow$ Destination
SUBQ	#<data>, <ea>	8, 16, 32	Destination – Data $\Rightarrow$ Destination
SUBX	Dn, Dn – (An), – (An)	8, 16, 32 8, 16, 32	Destination – Source – X $\Rightarrow$ Destination
SWAP	Dn	16	
TAS	<ea>	8	Destination Tested Condition Codes bit 7 of Destination
TBLS/TBLU	<ea>, Dn Dym : Dyn, Dn	8, 16, 32	Dyn – Dym $\Rightarrow$ Temp (Temp * Dn [7 : 0]) $\Rightarrow$ Temp (Dym * 256) + Temp $\Rightarrow$ Dn

**Table 4-2 Instruction Set Summary (Continued)**

TBLSN/TBLUN	<ea>, Dn Dym : Dyn, Dn	8, 16, 32	Dyn – Dym ⇒ Temp (Temp * Dn [7 : 0]) / 256 ⇒ Temp Dym + Temp ⇒ Dn
TRAP	#<data>	none	SSP – 2 ⇒ SSP; format/vector offset ⇒ (SSP); SSP – 4 ⇒ SSP; PC ⇒ (SSP); SR ⇒ (SSP); vector address ⇒ PC
TRAPcc	none #<data>	none 16, 32	If cc true, then TRAP exception
TRAPV	none	none	If V set, then overflow TRAP exception
TST	<ea>	8, 16, 32	Source – 0, to set condition codes
UNLK	An	32	An ⇒ SP; (SP) ⇒ An, SP + 4 ⇒ SP

NOTES:

1. Privileged instruction.

#### 4.8.1 M68000 Family Compatibility

It is the philosophy of the M68000 family that all user-mode programs can execute unchanged on future derivatives of the M68000 family, and supervisor-mode programs and exception handlers should require only minimal alteration.

The CPU32 can be thought of as an intermediate member of the M68000 Family. Object code from an MC68000 or MC68010 may be executed on the CPU32. Many of the instruction and addressing mode extensions of the MC68020 are also supported. Refer to the *CPU32 Reference Manual (CPU32RM/AD)* for a detailed comparison of the CPU32 and MC68020 instruction set.

#### 4.8.2 Special Control Instructions

Low-power stop (LPSTOP) and table lookup and interpolate (TBL) instructions have been added to the MC68000 instruction set for use in controller applications.

##### 4.8.2.1 Low-Power Stop (LPSTOP)

In applications where power consumption is a consideration, the CPU32 forces the device into a low-power standby mode when immediate processing is not required. The low-power stop mode is entered by executing the LPSTOP instruction. The processor remains in this mode until a user-specified (or higher) interrupt level or reset occurs.

##### 4.8.2.2 Table Lookup and Interpolate (TBL)

To maximize throughput for real-time applications, reference data is often precalculated and stored in memory for quick access. Storage of many data points can require an inordinate amount of memory. The table lookup instruction requires that only a sample of data points be stored, reducing memory requirements. The TBL instruction recovers intermediate values using linear interpolation. Results can be rounded with a round-to-nearest algorithm.

### 4.8.2.3 Loop Mode Instruction Execution

The CPU32 has several features that provide efficient execution of program loops. One of these features is the DBcc looping primitive instruction. To increase the performance of the CPU32, a loop mode has been added to the processor. The loop mode is used by any single word instruction that does not change the program flow. Loop mode is implemented in conjunction with the DBcc instruction. **Figure 4-7** shows the required form of an instruction loop for the processor to enter loop mode.

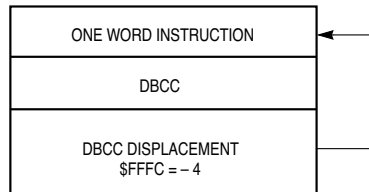

1126A

**Figure 4-7 Loop Mode Instruction Sequence**

The loop mode is entered when the DBcc instruction is executed, and the loop displacement is  $-4$ . Once in loop mode, the processor performs only the data cycles associated with the instruction and suppresses all instruction fetches. The termination condition and count are checked after each execution of the data operations of the looped instruction. The CPU32 automatically exits the loop mode on interrupts or other exceptions. All single word instructions that do not cause a change of flow can be looped.

## 4.9 Exception Processing

An exception is a special condition that preempts normal processing. Exception processing is the transition from normal mode program execution to execution of a routine that deals with an exception.

### 4.9.1 Exception Vectors

An exception vector is the address of a routine that handles an exception. The vector base register (VBR) contains the base address of a 1024-byte exception vector table, which consists of 256 exception vectors. Sixty-four vectors are defined by the processor, and 192 vectors are reserved for user definition as interrupt vectors. Except for the reset vector, each vector in the table is one long word in length. The reset vector is two long words in length. Refer to **Table 4-3** for information on vector assignment.

#### CAUTION

Because there is no protection on the 64 processor-defined vectors, external devices can access vectors reserved for internal purposes. This practice is strongly discouraged.

All exception vectors, except the reset vector and stack pointer, are located in supervisor data space. The reset vector and stack pointer are located in supervisor program space. Only the initial reset vector and stack pointer are fixed in the processor memory map. When initialization is complete, there are no fixed assignments. Since the VBR stores the vector table base address, the table can be located anywhere in memory. It can also be dynamically relocated for each task executed by an operating system.

**Table 4-3 Exception Vector Assignments**

Vector Number	Vector Offset			Assignment
	Dec	Hex	Space	
0	0	000	SP	Reset: initial stack pointer
1	4	004	SP	Reset: initial program counter
2	8	008	SD	Bus error
3	12	00C	SD	Address error
4	16	010	SD	Illegal instruction
5	20	014	SD	Zero division
6	24	018	SD	CHK, CHK2 instructions
7	28	01C	SD	TRAPcc, TRAPV instructions
8	32	020	SD	Privilege violation
9	36	024	SD	Trace
10	40	028	SD	Line 1010 emulator
11	44	02C	SD	Line 1111 emulator
12	48	030	SD	Hardware breakpoint
13	52	034	SD	(Reserved, coprocessor protocol violation)
14	56	038	SD	Format error and uninitialized interrupt
15	60	03C	SD	Format error and uninitialized interrupt
16–23	64	040	SD	(Unassigned, reserved)
	92	05C		
24	96	060	SD	Spurious interrupt
25	100	064	SD	Level 1 interrupt autovector
26	104	068	SD	Level 2 interrupt autovector
27	108	06C	SD	Level 3 interrupt autovector
28	112	070	SD	Level 4 interrupt autovector
29	116	074	SD	Level 5 interrupt autovector
30	120	078	SD	Level 6 interrupt autovector
31	124	07C	SD	Level 7 interrupt autovector
32–47	128	080	SD	Trap instruction vectors (0–15)
	188	0BC		
48–58	192	0C0	SD	(Reserved, coprocessor)
	232	0E8		
59–63	236	0EC	SD	(Unassigned, reserved)
	252	0FC		
64–255	256	100	SD	User defined vectors (192)
	1020	3FC		

Each vector is assigned an 8-bit number. Vector numbers for some exceptions are obtained from an external device; others are supplied by the processor. The processor multiplies the vector number by four to calculate vector offset, then adds the offset to the contents of the VBR. The sum is the memory address of the vector.

## 4.9.2 Types of Exceptions

An exception can be caused by internal or external events.

An internal exception can be generated by an instruction or by an error. The TRAP, TRAPcc, TRAPV, BKPT, CHK, CHK2, RTE, and DIV instructions can cause exceptions during normal execution. Illegal instructions, instruction fetches from odd addresses, word or long-word operand accesses from odd addresses, and privilege violations also cause internal exceptions.

Sources of external exception include interrupts, breakpoints, bus errors, and reset requests. Interrupts are peripheral device requests for processor action. Breakpoints are used to support development equipment. Bus error and reset are used for access control and processor restart.

## 4.9.3 Exception Processing Sequence

For all exceptions other than a reset exception, exception processing occurs in the following sequence. Refer to **5.7 Reset** for details of reset processing.

As exception processing begins, the processor makes an internal copy of the status register. After the copy is made, the processor state bits in the status register are changed — the S bit is set, establishing supervisor access level, and bits T1 and T0 are cleared, disabling tracing. For reset and interrupt exceptions, the interrupt priority mask is also updated.

Next, the exception number is obtained. For interrupts, the number is fetched from CPU space \$F (the bus cycle is an interrupt acknowledge). For all other exceptions, internal logic provides a vector number.

Next, current processor status is saved. An exception stack frame is created and placed on the supervisor stack. All stack frames contain copies of the status register and the program counter for use by RTE. The type of exception and the context in which the exception occurs determine what other information is stored in the stack frame.

Finally, the processor prepares to resume normal execution of instructions. The exception vector offset is determined by multiplying the vector number by four, and the offset is added to the contents of the VBR to determine displacement into the exception vector table. The exception vector is loaded into the program counter. If no other exception is pending, the processor will resume normal execution at the new address in the PC.

## 4.10 Development Support

The following features have been implemented on the CPU32 to enhance the instrumentation and development environment:

- M68000 Family Development Support
- Background Debug Mode
- Deterministic Opcode Tracking
- Hardware Breakpoints

#### 4.10.1 M68000 Family Development Support

All M68000 Family members include features to facilitate applications development. These features include the following:

**Trace on Instruction Execution** — M68000 Family processors include an instruction-by-instruction tracing facility as an aid to program development. The MC68020, MC68030, MC68040, and CPU32 also allow tracing only of those instructions causing a change in program flow. In the trace mode, a trace exception is generated after an instruction is executed, allowing a debugger program to monitor the execution of a program under test.

**Breakpoint Instruction** — An emulator may insert software breakpoints into the target code to indicate when a breakpoint has occurred. On the MC68010, MC68020, MC68030, and CPU32, this function is provided via illegal instructions, \$4848–\$484F, to serve as breakpoint instructions.

**Unimplemented Instruction Emulation** — During instruction execution, when an attempt is made to execute an illegal instruction, an illegal instruction exception occurs. Unimplemented instructions (F-line, A-line, . . .) utilize separate exception vectors to permit efficient emulation of unimplemented instructions in software.

#### 4.10.2 Background Debug Mode

Microcomputer systems generally provide a debugger, implemented in software, for system analysis at the lowest level. The background debug mode (BDM) on the CPU32 is unique in that the debugger has been implemented in CPU microcode.

BDM incorporates a full set of debugging options: registers can be viewed or altered, memory can be read or written to, and test features can be invoked.

A resident debugger simplifies implementation of an in-circuit emulator. In a common setup (refer to **Figure 4-8**), emulator hardware replaces the target system processor. A complex, expensive pod-and-cable interface provides a communication path between the target system and the emulator.

By contrast, an integrated debugger supports use of a bus state analyzer (BSA) for incircuit emulation. The processor remains in the target system (refer to **Figure 4-9**) and the interface is simplified. The BSA monitors target processor operation and the on-chip debugger controls the operating environment. Emulation is much “closer” to target hardware, and many interfacing problems (for example, limitations on high-frequency operation, AC and DC parametric mismatches, and restrictions on cable length) are minimized.

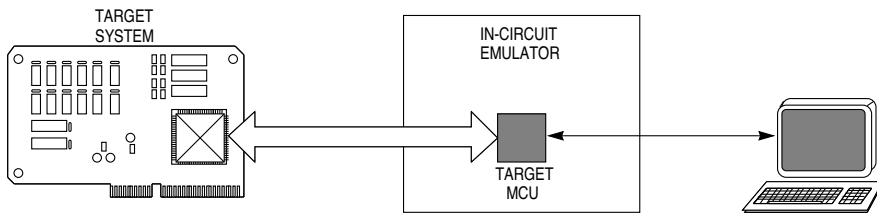

1128A

**Figure 4-8 Common In-Circuit Emulator Diagram**

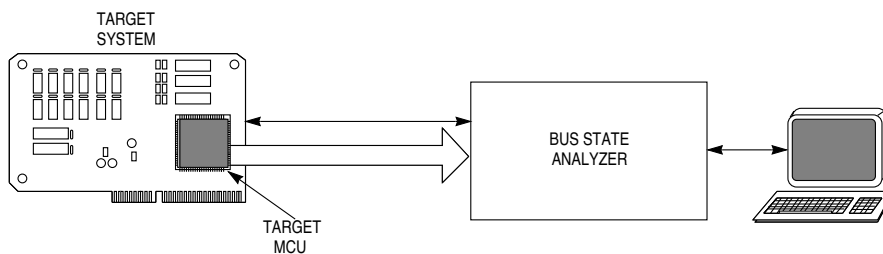

1129A

**Figure 4-9 Bus State Analyzer Configuration**

### 4.10.3 Enabling BDM

Accidentally entering BDM in a non-development environment can lock up the CPU32 when the serial command interface is not available. For this reason, BDM is enabled during reset via the breakpoint ( $\overline{\text{BKPT}}$ ) signal.

BDM operation is enabled when  $\overline{\text{BKPT}}$  is asserted (low), at the rising edge of  $\overline{\text{RESET}}$ . BDM remains enabled until the next system reset. A high  $\overline{\text{BKPT}}$  signal on the trailing edge of  $\overline{\text{RESET}}$  disables BDM.  $\overline{\text{BKPT}}$  is latched again on each rising transition of  $\overline{\text{RESET}}$ .  $\overline{\text{BKPT}}$  is synchronized internally, and must be held low for at least two clock cycles prior to negation of  $\overline{\text{RESET}}$ .

BDM enable logic must be designed with special care. If hold time on  $\overline{\text{BKPT}}$  (after the trailing edge of  $\overline{\text{RESET}}$ ) extends into the first bus cycle following reset, the bus cycle could inadvertently be tagged with a breakpoint. Refer to the *SIM Reference Manual* (SIMRM/AD) for timing information.

### 4.10.4 BDM Sources

When BDM is enabled, any of several sources can cause the transition from normal mode to BDM. These sources include external breakpoint hardware, the BGND instruction, a double bus fault, and internal peripheral breakpoints. If BDM is not enabled when an exception condition occurs, the exception is processed normally.

**Table 4-4** summarizes the processing of each source for both enabled and disabled cases. As shown in **Table 4-4**, the  $\overline{\text{BKPT}}$  instruction never causes a transition into BDM.

**Table 4-4 BDM Source Summary**

Source	BDM Enabled	BDM Disabled
$\overline{\text{BKPT}}$	Background	Breakpoint Exception
Double Bus Fault	Background	Halted
BGND Instruction	Background	Illegal Instruction
$\overline{\text{BKPT}}$ Instruction	Opcode Substitution/ Illegal Instruction	Opcode Substitution/ Illegal Instruction

#### 4.10.4.1 External $\overline{\text{BKPT}}$ Signal

Once enabled, BDM is initiated whenever assertion of  $\overline{\text{BKPT}}$  is acknowledged. If BDM is disabled, a breakpoint exception (vector \$0C) is acknowledged. The  $\overline{\text{BKPT}}$  input has the same timing relationship to the data strobe trailing edge as does read cycle data. There is no breakpoint acknowledge bus cycle when BDM is entered.

#### 4.10.4.2 BGND Instruction

An illegal instruction, \$4AFA, is reserved for use by development tools. The CPU32 defines \$4AFA (BGND) to be a BDM entry point when BDM is enabled. If BDM is disabled, an illegal instruction trap is acknowledged.

#### 4.10.4.3 Double Bus Fault

The CPU32 normally treats a double bus fault, or two bus faults in succession, as a catastrophic system error, and halts. When this condition occurs during initial system debug (a fault in the reset logic), further debugging is impossible until the problem is corrected. In BDM, the fault can be temporarily bypassed, so that the origin of the fault can be isolated and eliminated.

#### 4.10.4.4 Peripheral Breakpoints

CPU32 peripheral breakpoints are implemented in the same way as external breakpoints — peripherals request breakpoints by asserting the  $\overline{\text{BKPT}}$  signal. Consult the appropriate peripheral user's manual for additional details on the generation of peripheral breakpoints.

#### 4.10.5 Entering BDM

When the processor detects a breakpoint or a double bus fault, or decodes a BGND instruction, it suspends instruction execution and asserts the FREEZE output. This is the first indication that the processor has entered BDM. Once FREEZE has been asserted, the CPU enables the serial communication hardware and awaits a command.

The CPU writes a unique value indicating the source of BDM transition into temporary register A (ATEMP) as part of the process of entering BDM. A user can poll ATEMP and determine the source (refer to **Table 4-5**) by issuing a read system register command (RSREG). ATEMP is used in most debugger commands for temporary storage



— it is imperative that the RSREG command be the first command issued after transition into BDM.

**Table 4-5 Polling the BDM Entry Source**

Source	ATEMP[31:16]	ATEMP[15:0]
Double Bus Fault	SSW <sup>1</sup>	\$FFFF
BGND Instruction	\$0000	\$0001
Hardware Breakpoint	\$0000	\$0000

NOTES:

1. Special status word (SSW) is described in detail in the *CPU32 Reference Manual* (CPU32RM/AD).

A double bus fault during initial stack pointer/program counter (SP/PC) fetch sequence is distinguished by a value of \$FFFFFFFF in the current instruction PC. At no other time will the processor write an odd value into this register.

#### 4.10.6 BDM Commands

BDM commands consist of one 16-bit operation word and can include one or more 16-bit extension words. Each incoming word is read as it is assembled by the serial interface. The microcode routine corresponding to a command is executed as soon as the command is complete. Result operands are loaded into the output shift register to be shifted out as the next command is read. This process is repeated for each command until the CPU returns to normal operating mode. **Table 4-6** is a summary of background mode commands.

**Table 4-6 Background Mode Command Summary**

Command	Mnemonic	Description
Read D/A Register	RDREG/RAREG	Read the selected address or data register and return the results via the serial interface.
Write D/A Register	WDREG/WAREG	The data operand is written to the specified address or data register.
Read System Register	RSREG	The specified system control register is read. All registers that can be read in supervisor mode can be read in background mode.
Write System Register	WSREG	The operand data is written into the specified system control register.
Read Memory Location	READ	Read the sized data at the memory location specified by the long-word address. The source function code register (SFC) determines the address space accessed.
Write Memory Location	WRITE	Write the operand data to the memory location specified by the long-word address. The destination function code (DFC) register determines the address space accessed.
Dump Memory Block	DUMP	Used in conjunction with the READ command to dump large blocks of memory. An initial READ is executed to set up the starting address of the block and retrieve the first result. Subsequent operands are retrieved with the DUMP command.
Fill Memory Block	FILL	Used in conjunction with the WRITE command to fill large blocks of memory. An initial WRITE is executed to set up the starting address of the block and supply the first operand. Subsequent operands are written with the FILL command.
Resume Execution	GO	The pipe is flushed and re-filled before resuming instruction execution at the current PC.
Patch User Code	CALL	Current program counter is stacked at the location of the current stack pointer. Instruction execution begins at user patch code.
Reset Peripherals	RST	Asserts $\overline{\text{RESET}}$ for 512 clock cycles. The CPU is not reset by this command. Synonymous with the CPU RESET instruction.
No Operation	NOP	NOP performs no operation and may be used as a null command.

## 4.10.7 Background Mode Registers

BDM processing uses three special purpose registers to keep track of program context during development. A description of each follows.

### 4.10.7.1 Fault Address Register (FAR)

The FAR contains the address of the faulting bus cycle immediately following a bus or address error. This address remains available until overwritten by a subsequent bus cycle. Following a double bus fault, the FAR contains the address of the last bus cycle. The address of the first fault (if there was one) is not visible to the user.

### 4.10.7.2 Return Program Counter (RPC)

The RPC points to the location where fetching will commence after transition from background mode to normal mode. This register should be accessed to change the flow of a program under development. Changing the RPC to an odd value will cause an address error when normal mode prefetching begins.

#### 4.10.7.3 Current Instruction Program Counter (PCC)

The PCC holds a pointer to the first word of the last instruction executed prior to transition into background mode. Due to instruction pipelining, the instruction pointed to may not be the instruction which caused the transition. An example is a breakpoint on a released write. The bus cycle may overlap as many as two subsequent instructions before stalling the instruction sequencer. A breakpoint asserted during this cycle will not be acknowledged until the end of the instruction executing at completion of the bus cycle. PCC will contain \$00000001 if BDM is entered via a double bus fault immediately out of reset.

#### 4.10.8 Returning from BDM

BDM is terminated when a resume execution (GO) or call user code (CALL) command is received. Both GO and CALL flush the instruction pipeline and refetch instructions from the location pointed to by the RPC.

The return PC and the memory space referred to by the status register SUPV bit reflect any changes made during BDM. FREEZE is negated prior to initiating the first pre-fetch. Upon negation of FREEZE, the serial subsystem is disabled, and the signals revert to  $\overline{\text{IPIPE}}$ / $\overline{\text{IFETCH}}$  functionality.

#### 4.10.9 Serial Interface

Communication with the CPU32 during BDM occurs via a dedicated serial interface, which shares pins with other development features. **Figure 4-10** is a block diagram of the interface. The  $\overline{\text{BKPT}}$  signal becomes the serial clock (DSCLK); serial input data (DSI) is received on  $\overline{\text{IFETCH}}$ , and serial output data (DSO) is transmitted on  $\overline{\text{IPIPE}}$ .

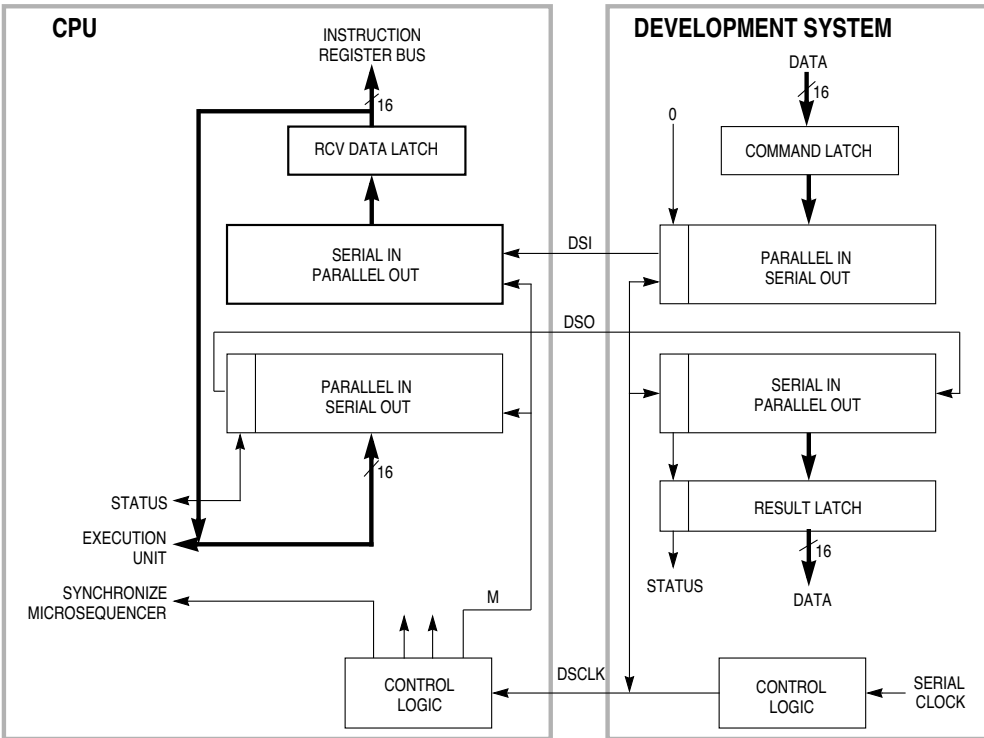

32 DEBUG I/O BLOCK

**Figure 4-10 Debug Serial I/O Block Diagram**

The serial interface uses a full-duplex synchronous protocol similar to the serial peripheral interface (SPI) protocol. The development system serves as the master of the serial link since it is responsible for the generation of DSCLK. If DSCLK is derived from the CPU32 system clock, development system serial logic is unhindered by the operating frequency of the target processor. Operable frequency range of the serial clock is from DC to one-half the processor system clock frequency.

The serial interface operates in full-duplex mode — data is transmitted and received simultaneously by both master and slave devices. In general, data transitions occur on the falling edge of DSCLK and are stable by the following rising edge of DSCLK. Data is transmitted MSB first, and is latched on the rising edge of DSCLK.

The serial data word is 17 bits wide, including 16 data bits and a status/control bit (refer to **Figure 4-11**). Bit 16 indicates the status of CPU-generated messages. **Table 4-7** shows the CPU-generated message types.

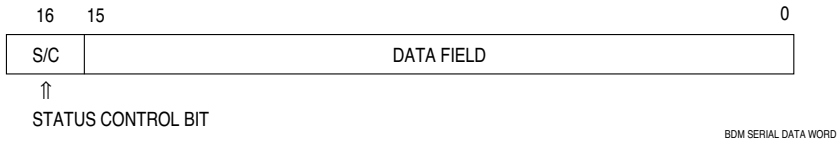

**Figure 4-11 BDM Serial Data Word**

**Table 4-7 CPU Generated Message Encoding**

Bit 16	Data	Message Type
0	XXXX	Valid Data Transfer
0	FFFF	Command Complete; Status OK
1	0000	Not Ready with Response; Come Again
1	0001	BERR Terminated Bus Cycle; Data Invalid
1	FFFF	Illegal Command

Command and data transfers initiated by the development system should clear bit 16. The current implementation ignores this bit; however, Motorola reserves the right to use this bit for future enhancements.

#### 4.10.10 Recommended BDM Connection

In order to provide for use of development tools when an MCU is installed in a system, Motorola recommends that appropriate signal lines be routed to a male Berg connector or double-row header installed on the circuit board with the MCU, as shown in the following figure.

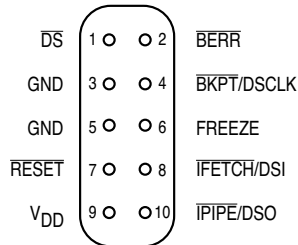

32 BERG

**Figure 4-12 BDM Connector Pinout**

#### **4.10.11 Deterministic Opcode Tracking**

CPU32 function code outputs are augmented by two supplementary signals to monitor the instruction pipeline. The instruction pipe ( $\overline{\text{IPIPE}}$ ) output indicates the start of each new instruction and each mid-instruction pipeline advance. The instruction fetch ( $\overline{\text{IFETCH}}$ ) output identifies the bus cycles in which the operand is loaded into the instruction pipeline. Pipeline flushes are also signaled with  $\overline{\text{IFETCH}}$ . Monitoring these two signals allows a bus state analyzer to synchronize itself to the instruction stream and monitor its activity.

#### **4.10.12 On-Chip Breakpoint Hardware**

An external breakpoint input and on-chip breakpoint hardware allow a breakpoint trap on any memory access. Off-chip address comparators preclude breakpoints unless show cycles are enabled. Breakpoints on instruction prefetches that are ultimately flushed from the instruction pipeline are not acknowledged; operand breakpoints are always acknowledged. Acknowledged breakpoints initiate exception processing at the address in exception vector number 12, or alternately enter background mode.

## SECTION 5 SYSTEM INTEGRATION MODULE

This section is an overview of the system integration module (SIM) function. Refer to the *SIM Reference Manual* (SIMRM/AD) for a comprehensive discussion of SIM capabilities. Refer to **D.2 System Integration Module** for information concerning the SIM address map and register structure.

### 5.1 General

The SIM consists of six functional blocks. **Figure 5-1** shows a block diagram of the SIM.

The system configuration block controls MCU configuration parameters.

The system clock generates clock signals used by the SIM, other IMB modules, and external devices.

The system protection block provides bus and software watchdog monitors. In addition, it also provides a periodic interrupt timer to support execution of time-critical control routines.

The external bus interface handles the transfer of information between IMB modules and external address space.

The chip-select block provides 12 chip-select signals. Each chip-select signal has an associated base address register and option register that contain the programmable characteristics of that chip-select.

The system test block incorporates hardware necessary for testing the MCU. It is used to perform factory tests, and its use in normal applications is not supported.

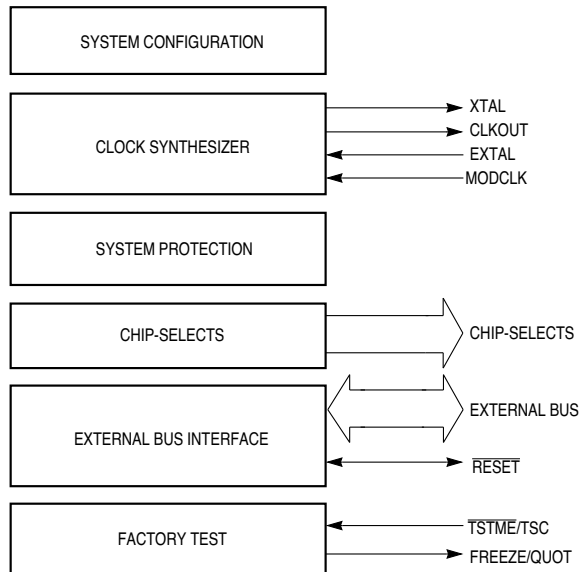

300 S(C)IM BLOCK

**Figure 5-1 System Integration Module Block Diagram**

## 5.2 System Configuration

The SIM configuration register (SIMCR) governs several aspects of system operation. The following paragraphs describe those configuration options controlled by SIMCR.

### 5.2.1 Module Mapping

Control registers for all the modules in the microcontroller are mapped into a 4-Kbyte block. The state of the module mapping bit (MM) in the SIM configuration register (SIMCR) determines where the control register block is located in the system memory map. When MM = 0, register addresses range from \$7FF000 to \$7FFFFFF; when MM = 1, register addresses range from \$FFF000 to \$FFFFFF.

### 5.2.2 Interrupt Arbitration

Each module that can request interrupts has an interrupt arbitration (IARB) field. Arbitration between interrupt requests of the same priority is performed by serial contention between IARB field bit values. Contention must take place whenever an interrupt request is acknowledged, even when there is only a single request pending. For an interrupt to be serviced, the appropriate IARB field must have a non-zero value. If an interrupt request from a module with an IARB field value of %0000 is recognized, the CPU32 processes a spurious interrupt exception.



Because the SIM routes external interrupt requests to the CPU32, the SIM IARB field value is used for arbitration between internal and external interrupts of the same priority. The reset value of IARB for the SIM is %1111, and the reset IARB value for all other modules is %0000, which prevents SIM interrupts from being discarded during initialization. Refer to **5.8 Interrupts** for a discussion of interrupt arbitration.

### 5.2.3 Show Internal Cycles

A show cycle allows internal bus transfers to be monitored externally. The SHEN field in SIMCR determines what the external bus interface does during internal transfer operations. **Table 5-1** shows whether data is driven externally, and whether external bus arbitration can occur. Refer to **5.6.6.1 Show Cycles** for more information.

**Table 5-1 Show Cycle Enable Bits**

SHEN[1:0]	Action
00	Show cycles disabled, external arbitration enabled
01	Show cycles enabled, external arbitration disabled
10	Show cycles enabled, external arbitration enabled
11	Show cycles enabled, external arbitration enabled; internal activity is halted by a bus grant

### 5.2.4 Register Access

The CPU32 can operate at one of two privilege levels. Supervisor level is more privileged than user level — all instructions and system resources are available at supervisor level, but access is restricted at user level. Effective use of privilege level can protect system resources from uncontrolled access. The state of the S bit in the CPU status register determines access level, and whether the user or supervisor stack pointer is used for stacking operations. The SUPV bit places SIM global registers in either supervisor or user data space. When SUPV = 0, registers with controlled access are accessible from either the user or supervisor privilege level; when SUPV = 1, registers with controlled access are restricted to supervisor access only.

### 5.2.5 Freeze Operation

The FREEZE signal halts MCU operations during debugging. FREEZE is asserted internally by the CPU32 if a breakpoint occurs while background mode is enabled. When FREEZE is asserted, only the bus monitor, software watchdog, and periodic interrupt timer are affected. The halt monitor and spurious interrupt monitor continue to operate normally. Setting the freeze bus monitor (FRZBM) bit in SIMCR disables the bus monitor when FREEZE is asserted. Setting the freeze software watchdog (FRZSW) bit disables the software watchdog and the periodic interrupt timer when FREEZE is asserted.

## 5.3 System Clock

The system clock in the SIM provides timing signals for the IMB modules and for an external peripheral bus. Because the MCU is a fully static design, register and memory contents are not affected when the clock rate changes. System hardware and software support changes in clock rate during operation.

The system clock signal can be generated from one of two sources. An internal phase-locked loop (PLL) can synthesize the clock from a fast reference, or the clock signal can be directly input from an external frequency source. The fast reference is typically a 4.194 MHz crystal, but may be generated by sources other than a crystal. Keep these sources in mind while reading the rest of this section. Refer to **Table A-4** in the **APPENDIX A ELECTRICAL CHARACTERISTICS** for clock specifications.

**Figure 5-2** is a block diagram of the clock submodule.

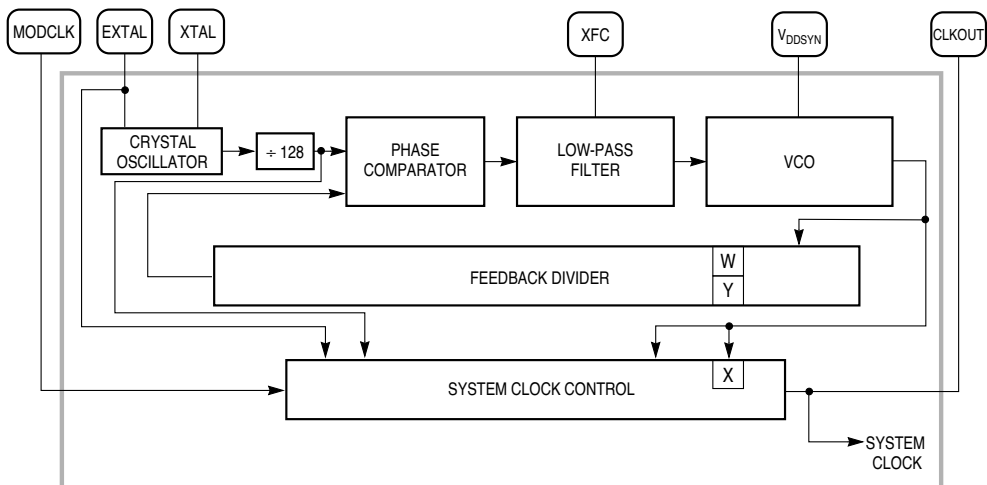

16/32 PLL BLOCK 4M

**Figure 5-2 System Clock Block Diagram**

### 5.3.1 Clock Sources

The state of the clock mode (MODCLK) pin during reset determines the system clock source. When MODCLK is held high during reset, the clock synthesizer generates a clock signal from an external reference frequency. The clock synthesizer control register (SYNCR) determines operating frequency and mode of operation. When MODCLK is held low during reset, the clock synthesizer is disabled and an external system clock signal must be driven onto the EXTERNAL pin.

The input clock is referred to as  $f_{ref}$ , and can be either a crystal or an external clock source. The output of the clock system is referred to as  $f_{sys}$ . Ensure that  $f_{ref}$  and  $f_{sys}$  are within normal operating limits.

To generate a reference frequency using the crystal oscillator, a reference crystal must be connected between the EXTAL and XTAL pins. Typically, a 4.194 MHz crystal is used, but the frequency may vary between 1 and 6 MHz. **Figure 5-3** shows a typical circuit.

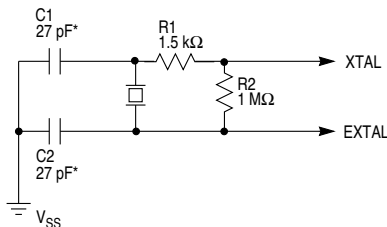

\* RESISTANCE AND CAPACITANCE BASED ON A TEST CIRCUIT CONSTRUCTED WITH A KDS041-18 4.194 MHz CRYSTAL. SPECIFIC COMPONENTS MUST BE BASED ON CRYSTAL TYPE. CONTACT CRYSTAL VENDOR FOR EXACT CIRCUIT.

32 OSCILLATOR 4M

**Figure 5-3 System Clock Oscillator Circuit**

If a fast reference frequency is provided to the PLL from a source other than a crystal, or an external system clock signal is applied through the EXTAL pin, the XTAL pin must be left floating.

When an external system clock signal is applied (MODCLK = 0 during reset), the PLL is disabled. The duty cycle of this signal is critical, especially at operating frequencies close to maximum. The relationship between clock signal duty cycle and clock signal period is expressed as follows:

$$\text{Minimum External Clock Period} = \frac{\text{Minimum External Clock High/Low Time}}{50\% - \text{Percentage Variation of External Clock Input Duty Cycle}}$$

### 5.3.2 Clock Synthesizer Operation

$V_{DDSYN}$  is used to power the clock circuits when the system clock is synthesized from either a crystal or an externally supplied reference frequency. A separate power source increases MCU noise immunity and can be used to run the clock when the MCU is powered down. A quiet power supply must be used as the  $V_{DDSYN}$  source. Adequate external bypass capacitors should be placed as close as possible to the  $V_{DDSYN}$  pin to assure a stable operating frequency. When an external system clock signal is applied and the PLL is disabled,  $V_{DDSYN}$  should be connected to the  $V_{DD}$  supply. Refer to the *SIM Reference Manual* (SIMRM/AD) for more information regarding system clock power supply conditioning.

A voltage controlled oscillator (VCO) in the PLL generates the system clock signal. To maintain a 50% clock duty cycle, the VCO frequency ( $f_{VCO}$ ) is either two or four times the system clock frequency, depending on the state of the X bit in SYNCR. The clock signal is fed back to a divider/counter. The divider controls the frequency of one input to a phase comparator. The other phase comparator input is a reference signal, either from the crystal oscillator or from an external source. The comparator generates a control signal proportional to the difference in phase between the two inputs. This signal is low-pass filtered and used to correct the VCO output frequency.

Filter circuit implementation can vary, depending upon the external environment and required clock stability. **Figure 5-4** shows two recommended system clock filter networks. XFC pin leakage must be kept as low as possible to maintain optimum stability and PLL performance.

An external filter network connected to the XFC pin is not required when an external system clock signal is applied and the PLL is disabled ( $MODCLK = 0$  at reset). The XFC pin must be left floating in this case.

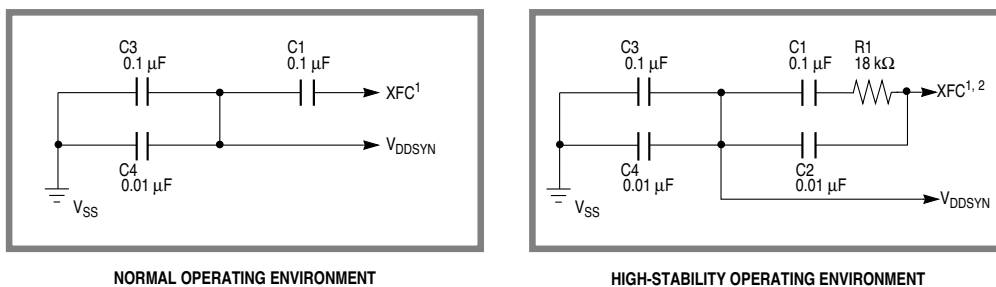

1. MAINTAIN LOW LEAKAGE ON THE XFC NODE. REFER TO **APPENDIX A ELECTRICAL CHARACTERISTICS** FOR MORE INFORMATION.
2. RECOMMENDED LOOP FILTER FOR REDUCED SENSITIVITY TO LOW FREQUENCY NOISE.

NORMAL/HIGH-STABILITY XFC CONN

**Figure 5-4 System Clock Filter Networks**

The synthesizer locks when the VCO frequency is equal to  $f_{ref}$ . Lock time is affected by the filter time constant and by the amount of difference between the two comparator inputs. Whenever a comparator input changes, the synthesizer must relock. Lock status is shown by the SLOCK bit in SYNCR. During power-up, the MCU does not come out of reset until the synthesizer locks. Crystal type, characteristic frequency, and layout of external oscillator circuitry affect lock time.

When the clock synthesizer is used, SYNCR determines the system clock frequency and certain operating parameters. The W and Y[5:0] bits are located in the PLL feedback path, enabling frequency multiplication by a factor of up to 256. When the W or Y values change, VCO frequency changes, and there is a VCO relock delay. The SYNCR X bit controls a divide-by circuit that is not in the synthesizer feedback loop. When X = 0 (reset state), a divide-by-four circuit is enabled, and the system clock frequency is one-fourth the VCO frequency ( $f_{VCO}$ ). When X = 1, a divide-by-two circuit is enabled and system clock frequency is one-half the VCO frequency ( $f_{VCO}$ ). There is no relock delay when clock speed is changed by the X bit.

Clock frequency is determined by SYNCR bit settings as follows:

$$f_{\text{sys}} = \frac{f_{\text{ref}}}{128} [4(Y + 1)(2^{(2W + X)})]$$

The reset state of SYNCR (\$3F00) results in a power-on  $f_{\text{sys}}$  of 8.388 MHz when  $f_{\text{ref}}$  is 4.194 MHz.

For the device to operate correctly, the clock frequency selected by the W, X, and Y bits must be within the limits specified for the MCU.

Internal VCO frequency is determined by the following equations:

$$f_{VCO} = 4f_{\text{sys}} \text{ if } X = 0$$

or

$$f_{VCO} = 2f_{\text{sys}} \text{ if } X = 1$$

**Table 5-2** shows clock control multipliers for all possible combinations of SYNCR bits. To obtain clock frequency, find counter modulus in the leftmost column, then multiply the reference frequency by the value in the appropriate prescaler cell. Shaded cells exceed the maximum system clock frequency at the time of manual publication; however, they may be usable in the future. Refer to **APPENDIX A ELECTRICAL CHARACTERISTICS** for maximum allowable clock rate.

**Table 5-3** shows clock frequencies available with a 4.194 MHz reference and a maximum specified clock frequency of 20.97 MHz. To obtain clock frequency, find counter modulus in the leftmost column, then refer to appropriate prescaler cell. Shaded cells exceed the maximum system clock frequency at the time of manual publication; however, they may be usable in the future. Refer to **APPENDIX A ELECTRICAL CHARACTERISTICS** for maximum system frequency ( $f_{\text{sys}}$ ).

**Table 5-2 Clock Control Multipliers**

Modulus Y	Prescalers			
	[W:X] = 00	[W:X] = 01	[W:X] = 10	[W:X] = 11
000000	.03125	.625	.125	.25
000001	.0625	.125	.25	.5
000010	.09375	.1875	.375	.75
000011	.125	.25	.5	1
000100	.15625	.3125	.625	1.25
000101	.1875	.375	.75	1.5
000110	.21875	.4375	.875	1.75
000111	.25	.5	1	2
001000	.21825	.5625	1.125	2.25
001001	.3125	.625	1.25	2.5
001010	.34375	.6875	1.375	2.75
001011	.375	.75	1.5	3
001100	.40625	.8125	1.625	3.25
001101	.4375	.875	1.75	3.5
001110	.46875	.9375	1.875	3.75
001111	.5	1	2	4
010000	.53125	1.0625	2.125	4.25
010001	.5625	1.125	2.25	4.5
010010	.59375	1.1875	2.375	4.75
010011	.625	1.25	2.5	5
010100	.65625	1.3125	2.625	5.25
010101	.6875	1.375	2.75	5.5
010110	.71875	1.4375	2.875	5.75
010111	.75	1.5	3	6
011000	.78125	1.5625	3.125	6.25
011001	.8125	1.625	3.25	6.5
011010	.84375	1.6875	3.375	6.75
011011	.875	1.75	3.5	7
011100	.90625	1.8125	3.625	7.25
011101	.9375	1.875	3.75	7.5
011110	.96875	1.9375	3.875	7.75
011111	1	2	4	8

**Table 5-2 Clock Control Multipliers (Continued)**

Modulus Y	Prescalers			
	[W:X] = 00	[W:X] = 01	[W:X] = 10	[W:X] = 11
100000	1.03125	2.0625	4.125	8.25
100001	1.0625	2.125	4.25	8.5
100010	1.09375	2.1875	4.375	8.75
100011	1.125	2.25	4.5	9
100100	1.15625	2.3125	4.675	9.25
100101	1.1875	2.375	4.75	9.5
100110	1.21875	2.4375	4.875	9.75
100111	1.25	2.5	5	10
101000	1.28125	2.5625	5.125	10.25
101001	1.3125	2.625	5.25	10.5
101010	1.34375	2.6875	5.375	10.75
101011	1.375	2.75	5.5	11
101100	1.40625	2.8125	5.625	11.25
101101	1.4375	2.875	5.75	11.5
101110	1.46875	2.9375	5.875	11.75
101111	1.5	3	6	12
110000	1.53125	3.0625	6.125	12.25
110001	1.5625	3.125	6.25	12.5
110010	1.59375	3.1875	6.375	12.75
110011	1.625	3.25	6.5	13
110100	1.65625	3.3125	6.625	13.25
110101	1.6875	3.375	6.75	13.5
110110	1.71875	3.4375	6.875	13.75
110111	1.75	3.5	7	14
111000	1.78125	3.5625	7.125	14.25
111001	1.8125	3.625	7.25	14.5
111010	1.84375	3.6875	7.375	14.75
111011	1.875	3.75	7.5	15
111100	1.90625	3.8125	7.625	15.25
111101	1.9375	3.875	7.75	15.5
111110	1.96875	3.9375	7.875	15.75
111111	2	4	8	16

**Table 5-3 System Frequencies from 4.194 MHz Reference**

Modulus Y	Prescaler			
	[W:X] = 00	[W:X] = 01	[W:X] = 10	[W:X] = 11
000000	131 kHz	262 kHz	524 kHz	1049 kHz
000001	262	524	1049	2097
000010	393	786	1573	3146
000011	524	1049	2097	4194
000100	655	1311	2621	5243
000101	786	1573	3146	6291
000110	918	1835	3670	7340
000111	1049	2097	4194	8389
001000	1180	2359	4719	9437
001001	1311	2621	5243	10486
001010	1442	2884	5767	11534
001011	1573	3146	6291	12583
001100	1704	3408	6816	13631
001101	1835	3670	7340	14680
001110	1966	3932	7864	15729
001111	2097	4194	8389	16777
010000	2228	4456	8913	17826
010001	2359	4719	9437	18874
010010	2490	4981	9961	19923
010011	2621	5243	10486	20972
010100	2753	5505	11010	22020
010101	2884	5767	11534	23069
010110	3015	6029	12059	24117
010111	3146	6291	12583	25166
011000	3277	6554	13107	26214
011001	3408	6816	13631	27263
011010	3539	7078	14156	28312
011011	3670	7340	14680	29360
011100	3801	7602	15204	30409
011101	3932	7864	15729	31457
011110	4063	8126	16253	32506
011111	4194	8389	16777	33554



**Table 5-3 System Frequencies from 4.194 MHz Reference (Continued)**

Modulus Y	Prescaler			
	[W:X] = 00	[W:X] = 01	[W:X] = 10	[W:X] = 11
100000	4325 kHz	8651 kHz	17302 kHz	34603 kHz
100001	4456	8913	17826	35652
100010	4588	9175	18350	36700
100011	4719	9437	18874	37749
100100	4850	9699	19399	38797
100101	4981	9961	19923	39846
100110	5112	10224	20447	40894
100111	5243	10486	20972	41943
101000	5374	10748	21496	42992
101001	5505	11010	22020	44040
101010	5636	11272	22544	45089
101011	5767	11534	23069	46137
101100	5898	11796	23593	47186
101101	6029	12059	24117	48234
101110	6160	12321	24642	49283
101111	6291	12583	25166	50332
110000	6423	12845	25690	51380
110001	6554	13107	26214	52428
110010	6685	13369	26739	53477
110011	6816	13631	27263	54526
110100	6947	13894	27787	55575
110101	7078	14156	28312	56623
110110	7209	14418	28836	57672
110111	7340	14680	29360	58720
111000	7471	14942	2988	59769
111001	7602	15204	30409	60817
111010	7733	15466	30933	61866
111011	7864	15729	31457	62915
111100	7995	15991	31982	63963
111101	8126	16253	32506	65011
111110	8258	16515	33030	66060
111111	8389	16777	33554	67109

### 5.3.3 External Bus Clock

The state of the E-clock division bit (EDIV) in SYNCR determines clock rate for the E-clock signal (ECLK) available on pin ADDR23. ECLK is a bus clock for M6800 devices and peripherals. ECLK frequency can be set to system clock frequency divided by eight or system clock frequency divided by sixteen. The clock is enabled by the  $\overline{CS10}$  field in chip-select pin assignment register 1 (CSPAR1). ECLK operation during low-power stop is described in the following paragraph. Refer to **5.9 Chip-Selects** for more information about the external bus clock.

### 5.3.4 Low-Power Operation

Low-power operation is initiated by the CPU32. To reduce power consumption selectively, the CPU can set the STOP bits in each module configuration register. To minimize overall microcontroller power consumption, the CPU can execute the LPSTOP instruction, which causes the SIM to turn off the system clock.

When individual module STOP bits are set, clock signals inside each module are turned off, but module registers are still accessible.

When the CPU executes LPSTOP, a special CPU space bus cycle writes a copy of the current interrupt mask into the clock control logic. The SIM brings the MCU out of low-power stop mode when one of the following exceptions occur:

- $\overline{RESET}$
- Trace
- SIM interrupt of higher priority than the stored interrupt mask

Refer to **5.6.4.2 LPSTOP Broadcast Cycle** and **4.8.2.1 Low-Power Stop (LPSTOP)** for more information.

During low-power stop mode, unless the system clock signal is supplied by an external source and that source is removed, the SIM clock control logic and the SIM clock signal (SIMCLK) continue to operate. The periodic interrupt timer and input logic for the  $\overline{RESET}$  and  $\overline{IRQ}$  pins are clocked by SIMCLK, and can be used to bring the processor out of LPSTOP. Optionally, the SIM can also continue to generate the CLKOUT signal while in low-power stop mode.

STSIM and STEXT bits in SYNCR determine clock operation during low-power stop mode.

The flowchart shown in **Figure 5-5** summarizes the effects of the STSIM and STEXT bits when the MCU enters normal low power stop mode. Any clock in the off state is held low. If the synthesizer VCO is turned off during low-power stop mode, there is a PLL relock delay after the VCO is turned back on.

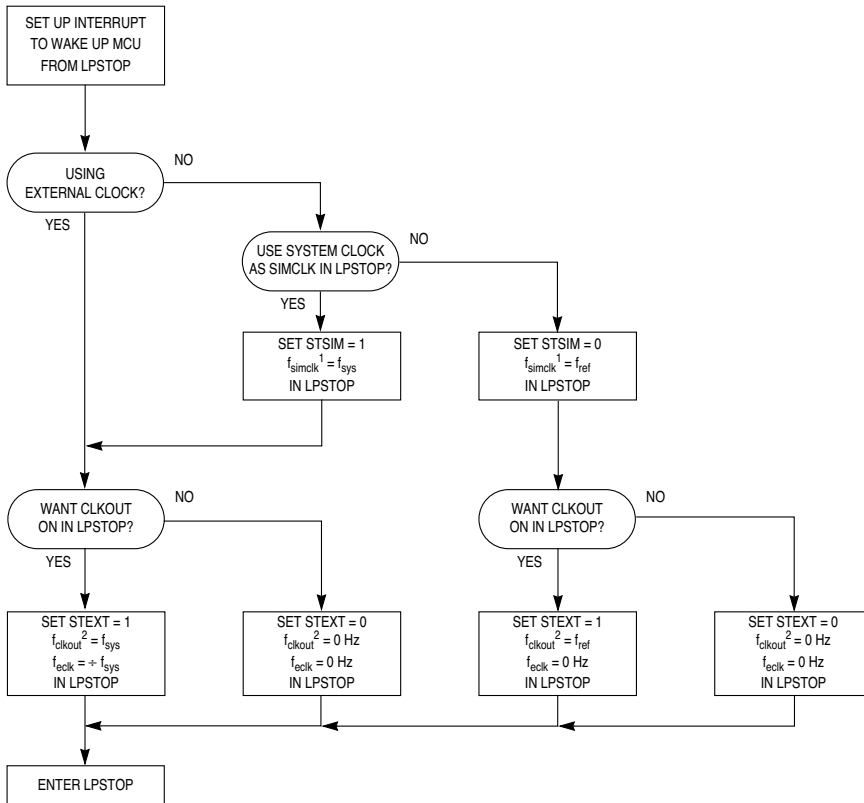

NOTES:

1. THE SIMCLK IS USED BY THE PIT, IRQ, AND INPUT BLOCKS OF THE SIM.

2. CLKOUT CONTROL DURING LPSTOP IS OVERRIDDEN BY THE EXOFF BIT IN SIMCR. IF EXOFF = 1, THE CLKOUT PIN IS ALWAYS IN A HIGH IMPEDANCE STATE AND STEXT HAS NO EFFECT IN LPSTOP. IF EXOFF = 0, CLKOUT IS CONTROLLED BY STEXT IN LPSTOP.

LPSTOPFLOW

Figure 5-5 LPSTOP Flowchart

## 5.4 System Protection

The system protection block preserves reset status, monitors internal activity, and provides periodic interrupt generation. **Figure 5-6** is a block diagram of the submodule.

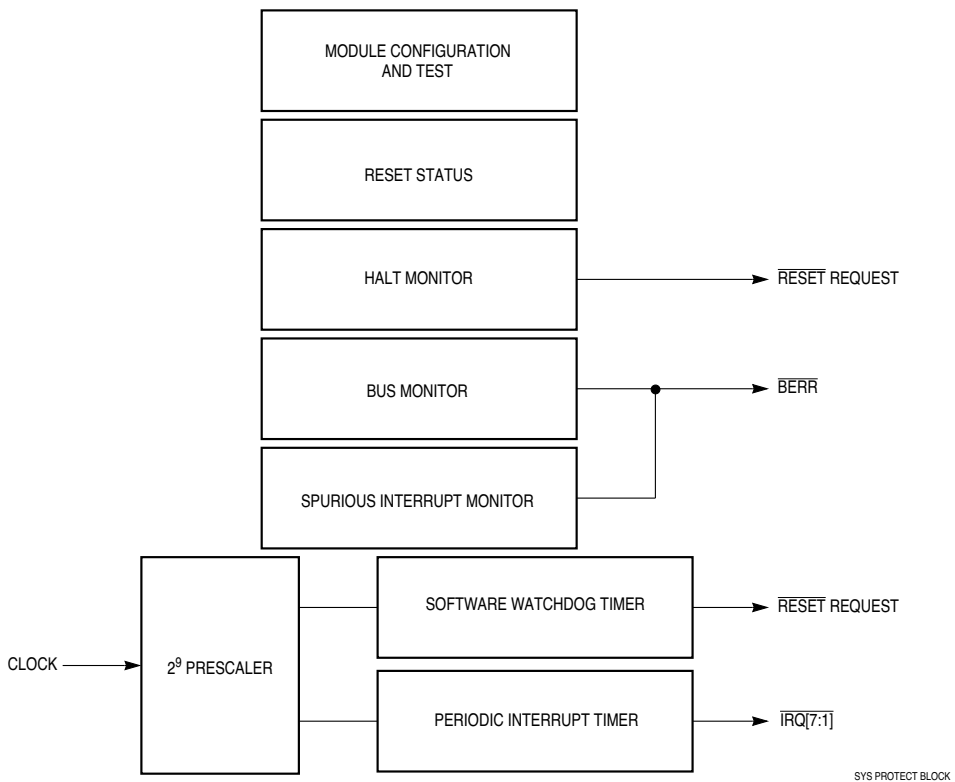

**Figure 5-6 System Protection Block**

### 5.4.1 Reset Status

The reset status register (RSR) latches internal MCU status during reset. Refer to **5.7.10 Reset Status Register** for more information.

### 5.4.2 Bus Monitor

The internal bus monitor checks data and size acknowledge ( $\overline{DSACK}$ ) or autovector ( $\overline{AVEC}$ ) signal response times during normal bus cycles. The monitor asserts the internal bus error ( $\overline{BERR}$ ) signal when the response time is excessively long.

$\overline{DSACK}$  and  $\overline{AVEC}$  response times are measured in clock cycles. Maximum allowable response time can be selected by setting the bus monitor timing (BMT[1:0]) field in the system protection control register (SYPCR). **Table 5-4** shows the periods allowed.

**Table 5-4 Bus Monitor Period**

<b>BMT[1:0]</b>	<b>Bus Monitor Time-Out Period</b>
00	64 system clocks
01	32 system clocks
10	16 system clocks
11	8 system clocks

The monitor does not check  $\overline{DSACK}$  response on the external bus unless the CPU32 initiates a bus cycle. The BME bit in SYPCR enables the internal bus monitor for internal to external bus cycles. If a system contains external bus masters, an external bus monitor must be implemented and the internal-to-external bus monitor option must be disabled.

When monitoring transfers to an 8-bit port, the bus monitor does not reset until both byte accesses of a word transfer are completed. Monitor time-out period must be at least twice the number of clocks that a single byte access requires.

### 5.4.3 Halt Monitor

The halt monitor responds to an assertion of the  $\overline{HALT}$  signal on the internal bus, caused by a double bus fault. A flag in the reset status register (RSR) indicates that the last reset was caused by the halt monitor. Halt monitor reset can be inhibited by the halt monitor (HME) enable bit in SYPCR. Refer to **5.6.5.2 Double Bus Faults** for more information.

### 5.4.4 Spurious Interrupt Monitor

During interrupt exception processing, the CPU32 normally acknowledges an interrupt request, recognizes the highest priority source, and then either acquires a vector or responds to a request for autovectoring. The spurious interrupt monitor asserts the internal bus error signal ( $\overline{BERR}$ ) if no interrupt arbitration occurs during interrupt exception processing. The assertion of  $\overline{BERR}$  causes the CPU32 to load the spurious interrupt exception vector into the program counter. The spurious interrupt monitor cannot be disabled. Refer to **5.8 Interrupts** for more information. For detailed information about interrupt exception processing, refer to **4.9 Exception Processing**.

### 5.4.5 Software Watchdog

The software watchdog is controlled by the software watchdog enable (SWE) bit in SYPCR. When enabled, the watchdog requires that a service sequence be written to the software service register (SWSR) on a periodic basis. If servicing does not take place, the watchdog times out and asserts the  $\overline{RESET}$  signal.

Each time the service sequence is written, the software watchdog timer restarts. The sequence to restart consists of the following steps:

1. Write \$55 to SWSR.
2. Write \$AA to SWSR.

Both writes must occur before time-out in the order listed. Any number of instructions can be executed between the two writes.

Watchdog clock rate is affected by the software watchdog prescale (SWP) bit and the software watchdog timing (SWT[1:0]) field in SYPCR.

SWP determines system clock prescaling for the watchdog timer and determines that one of two options, either no prescaling or prescaling by a factor of 512, can be selected. The value of SWP is affected by the state of the MODCLK pin during reset, as shown in **Table 5-5**. System software can change SWP value.

**Table 5-5 MODCLK Pin and SWP Bit During Reset**

MODCLK	SWP
0 (PLL disabled)	1 ( $\div 512$ )
1 (PLL enabled)	0 ( $\div 1$ )

SWT[1:0] selects the divide ratio used to establish the software watchdog time-out period. The following equation calculates the time-out period for a fast reference frequency.

$$\text{Time-out Period} = \frac{(128)(\text{Divide Ratio Specified by SWP and SWT}[1:0])}{f_{\text{ref}}}$$

The following equation calculates the time-out period for an externally input clock frequency.

$$\text{Time-out Period} = \frac{\text{Divide Ratio Specified by SWP and SWT}[1:0]}{f_{\text{ref}}}$$

**Table 5-6** shows the divide ratio for each combination of SWP and SWT[1:0] bits. When SWT[1:0] are modified, a watchdog service sequence must be performed before the new time-out period can take effect.

**Table 5-6 Software Watchdog Ratio**

SWP	SWT[1:0]	Watchdog Time-Out Period
0	00	$2^9 \div f_{\text{sys}}$
0	01	$2^{11} \div f_{\text{sys}}$
0	10	$2^{13} \div f_{\text{sys}}$
0	11	$2^{15} \div f_{\text{sys}}$
1	00	$2^{18} \div f_{\text{sys}}$
1	01	$2^{20} \div f_{\text{sys}}$
1	10	$2^{22} \div f_{\text{sys}}$
1	11	$2^{24} \div f_{\text{sys}}$

**Figure 5-7** is a block diagram of the watchdog timer and the clock control for the periodic interrupt timer.

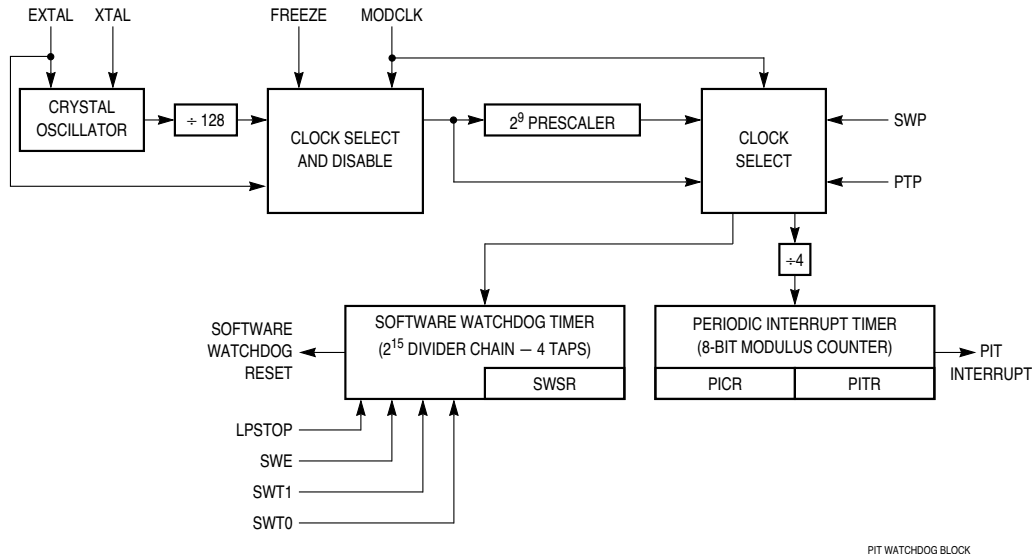

**Figure 5-7 Periodic Interrupt Timer and Software Watchdog Timer**

### 5.4.6 Periodic Interrupt Timer

The periodic interrupt timer (PIT) allows the generation of interrupts of specific priority at predetermined intervals. This capability is often used to schedule control system tasks that must be performed within time constraints. The timer consists of a prescaler, a modulus counter, and registers that determine interrupt timing, priority and vector assignment. Refer to **4.9 Exception Processing** for more information.

The periodic interrupt timer modulus counter is clocked by one of two signals. When the PLL is enabled ( $MODCLK = 1$  during reset),  $f_{ref} \div 128$  is used. When the PLL is disabled ( $MODCLK = 0$  during reset),  $f_{ref}$  is used. The value of the periodic timer prescaler (PTP) bit in the periodic interrupt timer register (PITR) determines system clock prescaling for the periodic interrupt timer. One of two options, either no prescaling, or prescaling by a factor of 512, can be selected. The value of PTP is affected by the state of the MODCLK pin during reset, as shown in **Table 5-7**. System software can change PTP value.

**Table 5-7 MODCLK Pin and PTP Bit at Reset**

MODCLK	PTP
0 (PLL disabled)	1 ( $\div 512$ )
1 (PLL enabled)	0 ( $\div 1$ )

Either clock signal selected by the PTP is divided by four before driving the modulus counter. The modulus counter is initialized by writing a value to the periodic interrupt timer modulus (PITM[7:0]) field in PITR. A zero value turns off the periodic timer. When the modulus counter value reaches zero, an interrupt is generated. The modulus counter is then reloaded with the value in PITM[7:0] and counting repeats. If a new value is written to PITR, it is loaded into the modulus counter when the current count is completed.

When a fast reference frequency is used, the PIT period can be calculated as follows:

$$\text{PIT Period} = \frac{(128)(\text{PITM}[7:0])(1 \text{ if PTP} = 0, 512 \text{ if PTP} = 1)(4)}{f_{\text{ref}}}$$

When an externally input clock frequency is used, the PIT period can be calculated as follows:

$$\text{PIT Period} = \frac{(\text{PITM}[7:0])(1 \text{ if PTP} = 0, 512 \text{ if PTP} = 1)(4)}{f_{\text{ref}}}$$

#### 5.4.7 Interrupt Priority and Vectoring

Interrupt priority and vectoring are determined by the values of the periodic interrupt request level (PIRQL[2:0]) and periodic interrupt vector (PIV) fields in the periodic interrupt control register (PICR).

The PIRQL field is compared to the CPU32 interrupt priority mask to determine whether the interrupt is recognized. **Table 5-8** shows PIRQL[2:0] priority values. Because of SIM hardware prioritization, a PIT interrupt is serviced before an external interrupt request of the same priority. The periodic timer continues to run when the interrupt is disabled.

**Table 5-8 Periodic Interrupt Priority**

PIRQL[2:0]	Priority Level
000	Periodic interrupt disabled
001	Interrupt priority level 1
010	Interrupt priority level 2
011	Interrupt priority level 3
100	Interrupt priority level 4
101	Interrupt priority level 5
110	Interrupt priority level 6
111	Interrupt priority level 7

The PIV field contains the periodic interrupt vector. The vector is placed on the IMB when an interrupt request is made. The vector number is used to calculate the address of the appropriate exception vector in the exception vector table. The reset value of the PIV field is \$0F, which corresponds to the uninitialized interrupt exception vector.



### 5.4.8 Low-Power STOP Mode Operation

When the CPU32 executes the LPSTOP instruction, the current interrupt priority mask is stored in the clock control logic, internal clocks are disabled according to the state of the STSIM bit in the SYNCR, and the MCU enters low-power stop mode. The bus monitor, halt monitor, and spurious interrupt monitor are all inactive during low-power stop mode.

During low-power stop mode, the clock input to the software watchdog timer is disabled and the timer stops. The software watchdog begins to run again on the first rising clock edge after low-power stop mode ends. The watchdog is not reset by low-power stop mode. A service sequence must be performed to reset the timer.

The periodic interrupt timer does not respond to the LPSTOP instruction, but continues to run during LPSTOP. To stop the periodic interrupt timer, PITR must be loaded with a zero value before the LPSTOP instruction is executed. A PIT interrupt, or an external interrupt request, can bring the MCU out of low-power stop mode if it has a higher priority than the interrupt mask value stored in the clock control logic when low-power stop mode is initiated. LPSTOP can be terminated by a reset.

## 5.5 External Bus Interface

The external bus interface (EBI) transfers information between the internal MCU bus and external devices. **Figure 5-8** shows a basic system with external memory and peripherals.

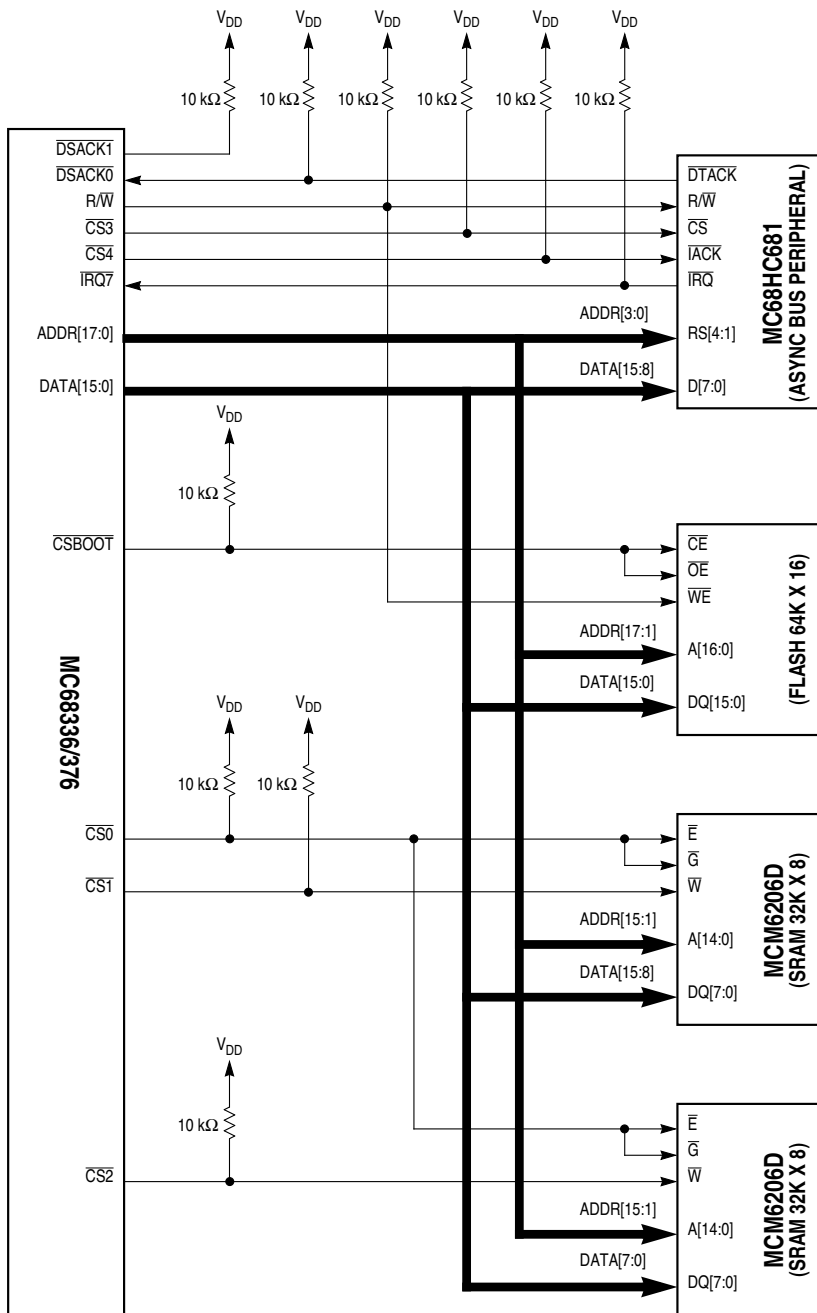

68300 SIMSCIM BUS

**Figure 5-8 MCU Basic System**

The external bus has 24 address lines and 16 data lines. The EBI provides dynamic sizing between 8-bit and 16-bit data accesses. It supports byte, word, and long-word transfers. Port width is the maximum number of bits accepted or provided during a bus transfer. Widths of eight and sixteen bits are accessed through the use of asynchronous cycles controlled by the size (SIZ1 and SIZ0) and data and size acknowledge ( $\overline{\text{DSACK1}}$  and  $\overline{\text{DSACK0}}$ ) pins. Multiple bus cycles may be required for dynamically sized transfers.

To add flexibility and minimize the necessity for external logic, MCU chip-select logic can be synchronized with EBI transfers. Refer to **5.9 Chip-Selects** for more information.

### 5.5.1 Bus Control Signals

The address bus provides addressing information to external devices. The data bus transfers 8-bit and 16-bit data between the MCU and external devices. Strobe signals, one for the address bus and another for the data bus, indicate the validity of an address and provide timing information for data.

Control signals indicate the beginning of each bus cycle, the address space it is to take place in, the size of the transfer, and the type of cycle. External devices decode these signals and respond to transfer data and terminate the bus cycle. The EBI operates in an asynchronous mode for any port width.

#### 5.5.1.1 Address Bus

Bus signals ADDR[23:0] define the address of the byte (or the most significant byte) to be transferred during a bus cycle. The MCU places the address on the bus at the beginning of a bus cycle. The address is valid while  $\overline{\text{AS}}$  is asserted.

#### 5.5.1.2 Address Strobe

Address strobe ( $\overline{\text{AS}}$ ) is a timing signal that indicates the validity of an address on the address bus and of many control signals. It is asserted one-half clock after the beginning of a bus cycle.

#### 5.5.1.3 Data Bus

Signals DATA[15:0] form a bidirectional, non-multiplexed parallel bus that transfers data to or from the MCU. A read or write operation can transfer eight or sixteen bits of data in one bus cycle. During a read cycle, the data is latched by the MCU on the last falling edge of the clock for that bus cycle. For a write cycle, all 16 bits of the data bus are driven, regardless of the port width or operand size. The MCU places the data on the data bus one-half clock cycle after  $\overline{\text{AS}}$  is asserted in a write cycle.

#### 5.5.1.4 Data Strobe

Data strobe ( $\overline{DS}$ ) is a timing signal. For a read cycle, the MCU asserts  $\overline{DS}$  to signal an external device to place data on the bus.  $\overline{DS}$  is asserted at the same time as  $\overline{AS}$  during a read cycle. For a write cycle,  $\overline{DS}$  signals an external device that data on the bus is valid. The MCU asserts  $\overline{DS}$  one full clock cycle after the assertion of  $\overline{AS}$  during a write cycle.

#### 5.5.1.5 Read/Write Signal

The read/write signal ( $R/\overline{W}$ ) determines the direction of the transfer during a bus cycle. This signal changes state, when required, at the beginning of a bus cycle, and is valid while  $\overline{AS}$  is asserted.  $R/\overline{W}$  only transitions when a write cycle is preceded by a read cycle or vice versa. The signal may remain low for two consecutive write cycles.

#### 5.5.1.6 Size Signals

Size signals ( $SIZ[1:0]$ ) indicate the number of bytes remaining to be transferred during an operand cycle. They are valid while the  $\overline{AS}$  is asserted. **Table 5-9** shows  $SIZ0$  and  $SIZ1$  encoding.

**Table 5-9 Size Signal Encoding**

$SIZ1$	$SIZ0$	Transfer Size
0	1	Byte
1	0	Word
1	1	Three bytes
0	0	Long word

#### 5.5.1.7 Function Codes

The CPU generates function code signals ( $FC[2:0]$ ) to indicate the type of activity occurring on the data or address bus. These signals can be considered address extensions that can be externally decoded to determine which of eight external address spaces is accessed during a bus cycle.

Address space 7 is designated CPU space. CPU space is used for control information not normally associated with read or write bus cycles. Function codes are valid while  $\overline{AS}$  is asserted.

**Table 5-10** shows address space encoding.

**Table 5-10 Address Space Encoding**

FC2	FC1	FC0	Address Space
0	0	0	Reserved
0	0	1	User data space
0	1	0	User program space
0	1	1	Reserved
1	0	0	Reserved
1	0	1	Supervisor data space
1	1	0	Supervisor program space
1	1	1	CPU space

The supervisor bit in the status register determines whether the CPU is operating in supervisor or user mode. Addressing mode and the instruction being executed determine whether a memory access is to program or data space.

#### 5.5.1.8 Data and Size Acknowledge Signals

During normal bus transfers, external devices assert the data and size acknowledge signals ( $\overline{\text{DSACK}}[1:0]$ ) to indicate port width to the MCU. During a read cycle, these signals tell the MCU to terminate the bus cycle and to latch data. During a write cycle, the signals indicate that an external device has successfully stored data and that the cycle can terminate.  $\overline{\text{DSACK}}[1:0]$  can also be supplied internally by chip-select logic. Refer to **5.9 Chip-Selects** for more information.

#### 5.5.1.9 Bus Error Signal

The bus error signal ( $\overline{\text{BERR}}$ ) is asserted when a bus cycle is not properly terminated by  $\overline{\text{DSACK}}$  or  $\overline{\text{AVEC}}$  assertion. It can also be asserted in conjunction with  $\overline{\text{DSACK}}$  to indicate a bus error condition, provided it meets the appropriate timing requirements. Refer to **5.6.5 Bus Exception Control Cycles** for more information.

The internal bus monitor can generate the  $\overline{\text{BERR}}$  signal for internal-to-internal and internal-to-external transfers. In systems with an external bus master, the SIM bus monitor must be disabled and external logic must be provided to drive the  $\overline{\text{BERR}}$  pin, because the internal  $\overline{\text{BERR}}$  monitor has no information about transfers initiated by an external bus master. Refer to **5.6.6 External Bus Arbitration** for more information.

#### 5.5.1.10 Halt Signal

The halt signal ( $\overline{\text{HALT}}$ ) can be asserted by an external device for debugging purposes to cause single bus cycle operation or (in combination with  $\overline{\text{BERR}}$ ) a retry of a bus cycle in error. The  $\overline{\text{HALT}}$  signal affects external bus cycles only. As a result, a program not requiring use of the external bus may continue executing, unaffected by the  $\overline{\text{HALT}}$  signal.

When the MCU completes a bus cycle with the  $\overline{\text{HALT}}$  signal asserted, DATA[15:0] is placed in a high-impedance state and bus control signals are driven inactive; the address, function code, size, and read/write signals remain in the same state. If  $\overline{\text{HALT}}$  is still asserted once bus mastership is returned to the MCU, the address, function code, size, and read/write signals are again driven to their previous states. The MCU does not service interrupt requests while it is halted. Refer to **5.6.5 Bus Exception Control Cycles** for more information.

#### 5.5.1.11 Autovector Signal

The autovector signal ( $\overline{\text{AVEC}}$ ) can be used to terminate external interrupt acknowledge cycles. Assertion of  $\overline{\text{AVEC}}$  causes the CPU32 to generate vector numbers to locate an interrupt handler routine. If  $\overline{\text{AVEC}}$  is continuously asserted, autovectors are generated for all external interrupt requests.  $\overline{\text{AVEC}}$  is ignored during all other bus cycles. Refer to **5.8 Interrupts** for more information.  $\overline{\text{AVEC}}$  for external interrupt requests can also be supplied internally by chip-select logic. Refer to **5.9 Chip-Selects** for more information. The autovector function is disabled when there is an external bus master. Refer to **5.6.6 External Bus Arbitration** for more information.

#### 5.5.2 Dynamic Bus Sizing

The MCU dynamically interprets the port size of an addressed device during each bus cycle, allowing operand transfers to or from 8-bit and 16-bit ports.

During an operand transfer cycle, an external device signals its port size and indicates completion of the bus cycle to the MCU through the use of the  $\overline{\text{DSACK}}$  inputs, as shown in **Table 5-11**. Chip-select logic can generate data and size acknowledge signals for an external device. Refer to **5.9 Chip-Selects** for more information.

**Table 5-11 Effect of  $\overline{\text{DSACK}}$  Signals**

$\overline{\text{DSACK1}}$	$\overline{\text{DSACK0}}$	Result
1	1	Insert Wait States in Current Bus Cycle
1	0	Complete Cycle — Data Bus Port Size is 8 Bits
0	1	Complete Cycle — Data Bus Port Size is 16 Bits
0	0	Reserved

If the CPU is executing an instruction that reads a long-word operand from a 16-bit port, the MCU latches the 16 bits of valid data and then runs another bus cycle to obtain the other 16 bits. The operation for an 8-bit port is similar, but requires four read cycles. The addressed device uses the  $\overline{\text{DSACK}}$  signals to indicate the port width. For instance, a 16-bit device always returns  $\overline{\text{DSACK}}$  for a 16-bit port (regardless of whether the bus cycle is a byte or word operation).

Dynamic bus sizing requires that the portion of the data bus used for a transfer to or from a particular port size be fixed. A 16-bit port must reside on data bus bits [15:0], and an 8-bit port must reside on data bus bits [15:8]. This minimizes the number of bus cycles needed to transfer data and ensures that the MCU transfers valid data.

The MCU always attempts to transfer the maximum amount of data on all bus cycles. For any bus access, it is assumed that the port is 16 bits wide when the bus cycle begins.

Operand bytes are designated as shown in **Figure 5-9**. OP[0:3] represent the order of access. For instance, OP0 is the most significant byte of a long-word operand, and is accessed first, while OP3, the least significant byte, is accessed last. The two bytes of a word-length operand are OP0 (most significant) and OP1. The single byte of a byte-length operand is OP0.

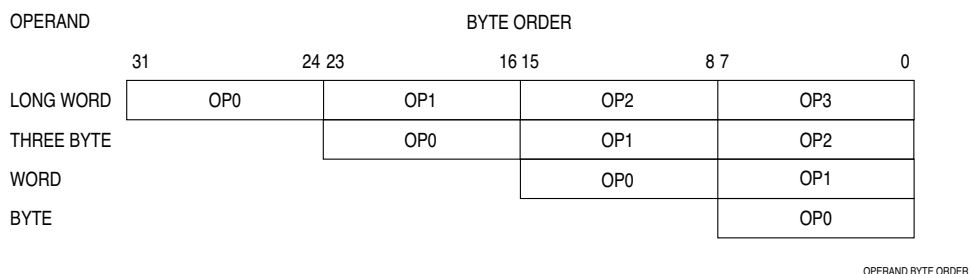

**Figure 5-9 Operand Byte Order**

### 5.5.3 Operand Alignment

The EBI data multiplexer establishes the necessary connections for different combinations of address and data sizes. The multiplexer takes the two bytes of the 16-bit bus and routes them to their required positions. Positioning of bytes is determined by the size and address outputs. SIZ1 and SIZ0 indicate the number of bytes remaining to be transferred during the current bus cycle. The number of bytes transferred is equal to or less than the size indicated by SIZ1 and SIZ0, depending on port width.

ADDR0 also affects the operation of the data multiplexer. During an operand transfer, ADDR[23:1] indicate the word base address of the portion of the operand to be accessed. ADDR0 indicates the byte offset from the base.

### 5.5.4 Misaligned Operands

The CPU32 uses a basic operand size of 16 bits. An operand is misaligned when it overlaps a word boundary. This is determined by the value of ADDR0. When ADDR0 = 0 (an even address), the address is on a word and byte boundary. When ADDR0 = 1 (an odd address), the address is on a byte boundary only. A byte operand is aligned at any address; a word or long-word operand is misaligned at an odd address. The CPU32 does not support misaligned transfers.

The largest amount of data that can be transferred by a single bus cycle is an aligned word. If the MCU transfers a long-word operand through a 16-bit port, the most significant operand word is transferred on the first bus cycle and the least significant operand word is transferred on a following bus cycle.

### 5.5.5 Operand Transfer Cases

**Table 5-12** is a summary of how operands are aligned for various types of transfers. OPn entries are portions of a requested operand that are read or written during a bus cycle and are defined by SIZ1, SIZ0, and ADDR0 for that bus cycle. The following paragraphs discuss all the allowable transfer cases in detail.

**Table 5-12 Operand Alignment**

Current Cycle	Transfer Case <sup>1</sup>	SIZ1	SIZ0	ADDR0	DSACK1	DSACK0	DATA [15:8]	DATA [7:0]	Next Cycle
1	Byte to 8-bit port (even)	0	1	0	1	0	OP0	(OP0) <sup>2</sup>	—
2	Byte to 8-bit port (odd)	0	1	1	1	0	OP0	(OP0)	—
3	Byte to 16-bit port (even)	0	1	0	0	1	OP0	(OP0)	—
4	Byte to 16-bit port (odd)	0	1	1	0	1	(OP0)	OP0	—
5	Word to 8-bit port	1	0	0	1	0	OP0	(OP1)	2
6	Word to 16-bit port	1	0	0	0	1	OP0	OP1	—
7	3-Byte to 8-bit port <sup>3</sup>	1	1	1	1	0	OP0	(OP0)	5
8	Long word to 8-bit port	0	0	0	1	0	OP0	(OP0)	7
9	Long word to 16-bit port	0	0	0	0	1	OP0	OP1	6

**NOTES:**

1. All transfers are aligned. The CPU32 does not support misaligned word or long-word transfers.
2. Operands in parentheses are ignored by the CPU32 during read cycles.
3. Three-Byte transfer cases occur only as a result of a long word to 8-bit port transfer.

### 5.6 Bus Operation

Internal microcontroller modules are typically accessed in two system clock cycles. Regular external bus cycles use handshaking between the MCU and external peripherals to manage transfer size and data. These accesses take three system clock cycles, with no wait states. During regular cycles, wait states can be inserted as needed by bus control logic. Refer to **5.6.2 Regular Bus Cycles** for more information.

Fast termination cycles, which are two-cycle external accesses with no wait states, use chip-select logic to generate handshaking signals internally. Chip-select logic can also be used to insert wait states before internal generation of handshaking signals. Refer to **5.6.3 Fast Termination Cycles** and **5.9 Chip-Selects** for more information. Bus control signal timing, as well as chip-select signal timing, are specified in **APPENDIX A ELECTRICAL CHARACTERISTICS**. Refer to the *SIM Reference Manual* (SIM-RM/AD) for more information about each type of bus cycle.

#### 5.6.1 Synchronization to CLKOUT

External devices connected to the MCU bus can operate at a clock frequency different from the frequencies of the MCU as long as the external devices satisfy the interface signal timing constraints. Although bus cycles are classified as asynchronous, they are interpreted relative to the MCU system clock output (CLKOUT).

Descriptions are made in terms of individual system clock states, labeled {S0, S1, S2,..., SN}. The designation “state” refers to the logic level of the clock signal and does not correspond to any implemented machine state. A clock cycle consists of two successive states. Refer to **Table A-4** for more information.



Bus cycles terminated by  $\overline{\text{DSACK}}$  assertion normally require a minimum of three CLKOUT cycles. To support systems that use CLKOUT to generate DSACK and other inputs, asynchronous input setup time and asynchronous input hold times are specified. When these specifications are met, the MCU is guaranteed to recognize the appropriate signal on a specific edge of the CLKOUT signal.

For a read cycle, when assertion of  $\overline{\text{DSACK}}$  is recognized on a particular falling edge of the clock, valid data is latched into the MCU on the next falling clock edge, provided that the data meets the data setup time. In this case, the parameter for asynchronous operation can be ignored.

When a system asserts  $\overline{\text{DSACK}}$  for the required window around the falling edge of S2 and obeys the bus protocol by maintaining  $\overline{\text{DSACK}}$  and  $\overline{\text{BERR}}$  or  $\overline{\text{HALT}}$  until and throughout the clock edge that negates  $\overline{\text{AS}}$  (with the appropriate asynchronous input hold time), no wait states are inserted. The bus cycle runs at the maximum speed of three clocks per cycle.

To ensure proper operation in a system synchronized to CLKOUT, when either  $\overline{\text{BERR}}$  or  $\overline{\text{BERR}}$  and  $\overline{\text{HALT}}$  is asserted after  $\overline{\text{DSACK}}$ ,  $\overline{\text{BERR}}$  (or  $\overline{\text{BERR}}$  and  $\overline{\text{HALT}}$ ) assertion must satisfy the appropriate data-in setup and hold times before the falling edge of the clock cycle after  $\overline{\text{DSACK}}$  is recognized.

## 5.6.2 Regular Bus Cycles

The following paragraphs contain a discussion of cycles that use external bus control logic. Refer to **5.6.3 Fast Termination Cycles** for information about fast termination cycles.

To initiate a transfer, the MCU asserts an address and the SIZ[1:0] signals. The SIZ signals and ADDR0 are externally decoded to select the active portion of the data bus. Refer to **5.5.2 Dynamic Bus Sizing**. When  $\overline{\text{AS}}$ ,  $\overline{\text{DS}}$ , and  $\text{R}/\overline{\text{W}}$  are valid, a peripheral device either places data on the bus (read cycle) or latches data from the bus (write cycle), then asserts a  $\overline{\text{DSACK}}[1:0]$  combination that indicates port size.

The  $\overline{\text{DSACK}}[1:0]$  signals can be asserted before the data from a peripheral device is valid on a read cycle. To ensure valid data is latched into the MCU, a maximum period between  $\overline{\text{DSACK}}$  assertion and  $\overline{\text{DS}}$  assertion is specified.

There is no specified maximum for the period between the assertion of  $\overline{\text{AS}}$  and  $\overline{\text{DSACK}}$ . Although the MCU can transfer data in a minimum of three clock cycles when the cycle is terminated with  $\overline{\text{DSACK}}$ , the MCU inserts wait cycles in clock period increments until either  $\overline{\text{DSACK}}$  signal goes low.

If bus termination signals remain unasserted, the MCU will continue to insert wait states, and the bus cycle will never end. If no peripheral responds to an access, or if an access is invalid, external logic should assert the  $\overline{\text{BERR}}$  or  $\overline{\text{HALT}}$  signals to abort the bus cycle (when  $\overline{\text{BERR}}$  and  $\overline{\text{HALT}}$  are asserted simultaneously, the CPU32 acts as though only  $\overline{\text{BERR}}$  is asserted). When enabled, the SIM bus monitor asserts  $\overline{\text{BERR}}$  when  $\overline{\text{DSACK}}$  response time exceeds a predetermined limit. The bus monitor timeout period is determined by the BMT[1:0] field in SYPCR. The maximum bus monitor timeout period is 64 system clock cycles.

### 5.6.2.1 Read Cycle

During a read cycle, the MCU transfers data from an external memory or peripheral device. If the instruction specifies a long-word or word operation, the MCU attempts to read two bytes at once. For a byte operation, the MCU reads one byte. The portion of the data bus from which each byte is read depends on operand size, peripheral address, and peripheral port size. **Figure 5-10** is a flowchart of a word read cycle. Refer to **5.5.2 Dynamic Bus Sizing**, **5.5.4 Misaligned Operands**, and the *SIM Reference Manual* (SIMRM/AD) for more information.

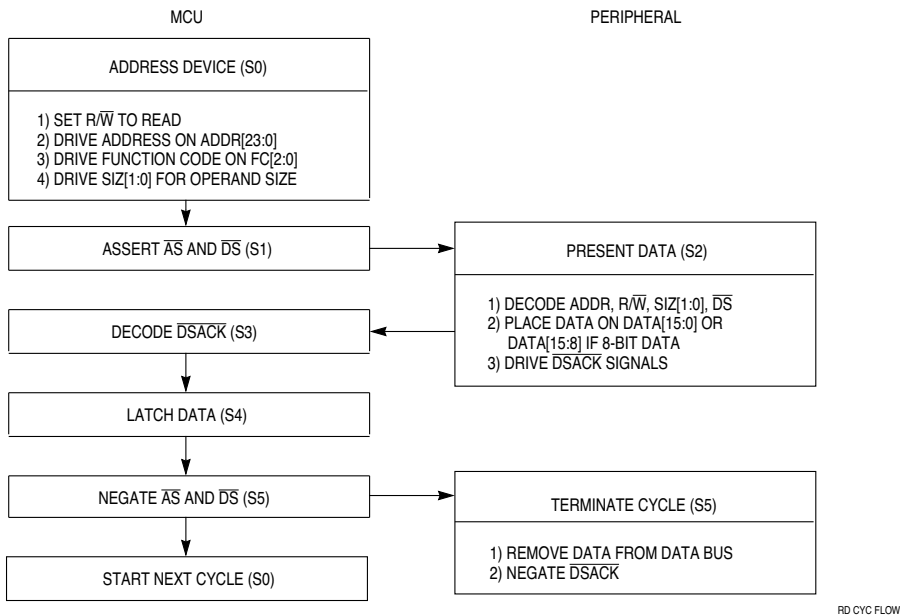
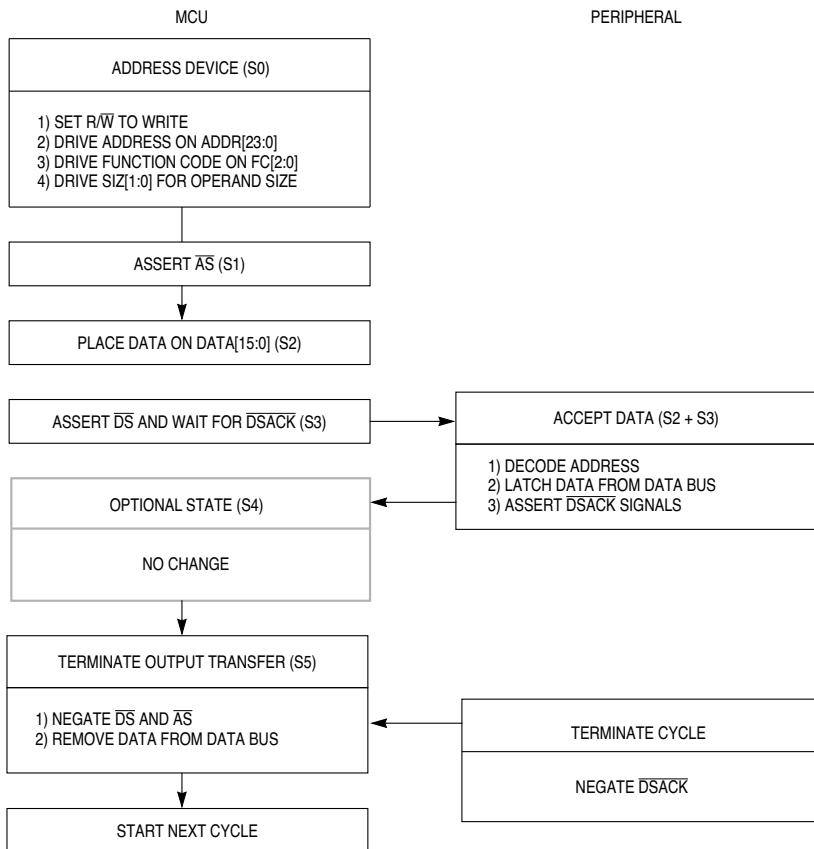

**Figure 5-10 Word Read Cycle Flowchart**

### 5.6.2.2 Write Cycle

During a write cycle, the MCU transfers data to an external memory or peripheral device. If the instruction specifies a long-word or word operation, the MCU attempts to write two bytes at once. For a byte operation, the MCU writes one byte. The portion of the data bus upon which each byte is written depends on operand size, peripheral address, and peripheral port size.

Refer to **5.5.2 Dynamic Bus Sizing** and **5.5.4 Misaligned Operands** for more information. **Figure 5-11** is a flowchart of a write-cycle operation for a word transfer. Refer to the *SIM Reference Manual (SIMRM/AD)* for more information.



WR CYC FLOW

**Figure 5-11 Write Cycle Flowchart**

### 5.6.3 Fast Termination Cycles

When an external device has a fast access time, the chip-select circuit fast termination option can provide a two-cycle external bus transfer. Because the chip-select circuits are driven from the system clock, the bus cycle termination is inherently synchronized with the system clock.

If multiple chip-selects are to be used to provide control signals to a single device and match conditions occur simultaneously, all  $\overline{\text{MODE}}$ ,  $\overline{\text{STRB}}$ , and associated  $\overline{\text{DSACK}}$  fields must be programmed to the same value. This prevents a conflict on the internal bus when the wait states are loaded into the  $\overline{\text{DSACK}}$  counter shared by all chip-selects.

Fast termination cycles use internal handshaking signals generated by the chip-select logic. To initiate a transfer, the MCU asserts an address and the  $\text{SIZ}[1:0]$  signals. When  $\overline{\text{AS}}$ ,  $\overline{\text{DS}}$ , and  $\text{R/W}$  are valid, a peripheral device either places data on the bus (read cycle) or latches data from the bus (write cycle). At the appropriate time, chip-select logic asserts data and size acknowledge signals.

The  $\overline{\text{DSACK}}$  option fields in the chip-select option registers determine whether internally generated  $\overline{\text{DSACK}}$  or externally generated  $\overline{\text{DSACK}}$  is used. The external  $\overline{\text{DSACK}}$  lines are always active, regardless of the setting of the  $\overline{\text{DSACK}}$  field in the chip-select option registers. Thus, an external  $\overline{\text{DSACK}}$  can always terminate a bus cycle. Holding a  $\overline{\text{DSACK}}$  line low will cause all external bus cycles to be three-cycle (zero wait states) accesses unless the chip-select option register specifies fast accesses.

For fast termination cycles, the fast termination encoding (%1110) must be used. Refer to **5.9.1 Chip-Select Registers** for information about fast termination setup.

To use fast termination, an external device must be fast enough to have data ready within the specified setup time (for example, by the falling edge of  $\text{S4}$ ). Refer to **Table A-6** and **Figures A-6** and **A-7** for information about fast termination timing.

When fast termination is in use,  $\overline{\text{DS}}$  is asserted during read cycles but not during write cycles. The  $\overline{\text{STRB}}$  field in the chip-select option register used must be programmed with the address strobe encoding to assert the chip-select signal for a fast termination write.

### 5.6.4 CPU Space Cycles

Function code signals  $\text{FC}[2:0]$  designate which of eight external address spaces is accessed during a bus cycle. Address space 7 is designated CPU space. CPU space is used for control information not normally associated with read or write bus cycles. Function codes are valid only while  $\overline{\text{AS}}$  is asserted. Refer to **5.5.1.7 Function Codes** for more information on codes and encoding.

During a CPU space access,  $\text{ADDR}[19:16]$  are encoded to reflect the type of access being made. **Figure 5-12** shows the three encodings used by 68300 family microcontrollers. These encodings represent breakpoint acknowledge (Type \$0) cycles, low power stop broadcast (Type \$3) cycles, and interrupt acknowledge (Type \$F) cycles. Refer to **5.8 Interrupts** for information about interrupt acknowledge bus cycles.



External breakpoint circuitry decodes the function code and address lines, places an instruction word on the data bus, and asserts  $\overline{\text{BERR}}$ . The CPU32 then performs hardware breakpoint exception processing: it acquires the number of the hardware breakpoint exception vector, computes the vector address from this number, loads the content of the vector address into the PC, and jumps to the exception handler routine at that address. If the external device asserts  $\overline{\text{DSACK}}$  rather than  $\overline{\text{BERR}}$ , the CPU32 ignores the breakpoint and continues processing.

When  $\overline{\text{BKPT}}$  assertion is synchronized with an instruction prefetch, processing of the breakpoint exception occurs at the end of that instruction. The prefetched instruction is “tagged” with the breakpoint when it enters the instruction pipeline. The breakpoint exception occurs after the instruction executes. If the pipeline is flushed before the tagged instruction is executed, no breakpoint occurs. When  $\overline{\text{BKPT}}$  assertion is synchronized with an operand fetch, exception processing occurs at the end of the instruction during which  $\overline{\text{BKPT}}$  is latched.

Refer to the *CPU32 Reference Manual* (CPU32RM/AD) and the *SIM Reference Manual* (SIMRM/AD) for additional information. Breakpoint operation flow for the CPU32 is shown in **Figure 5-13**.

BREAKPOINT OPERATION FLOW

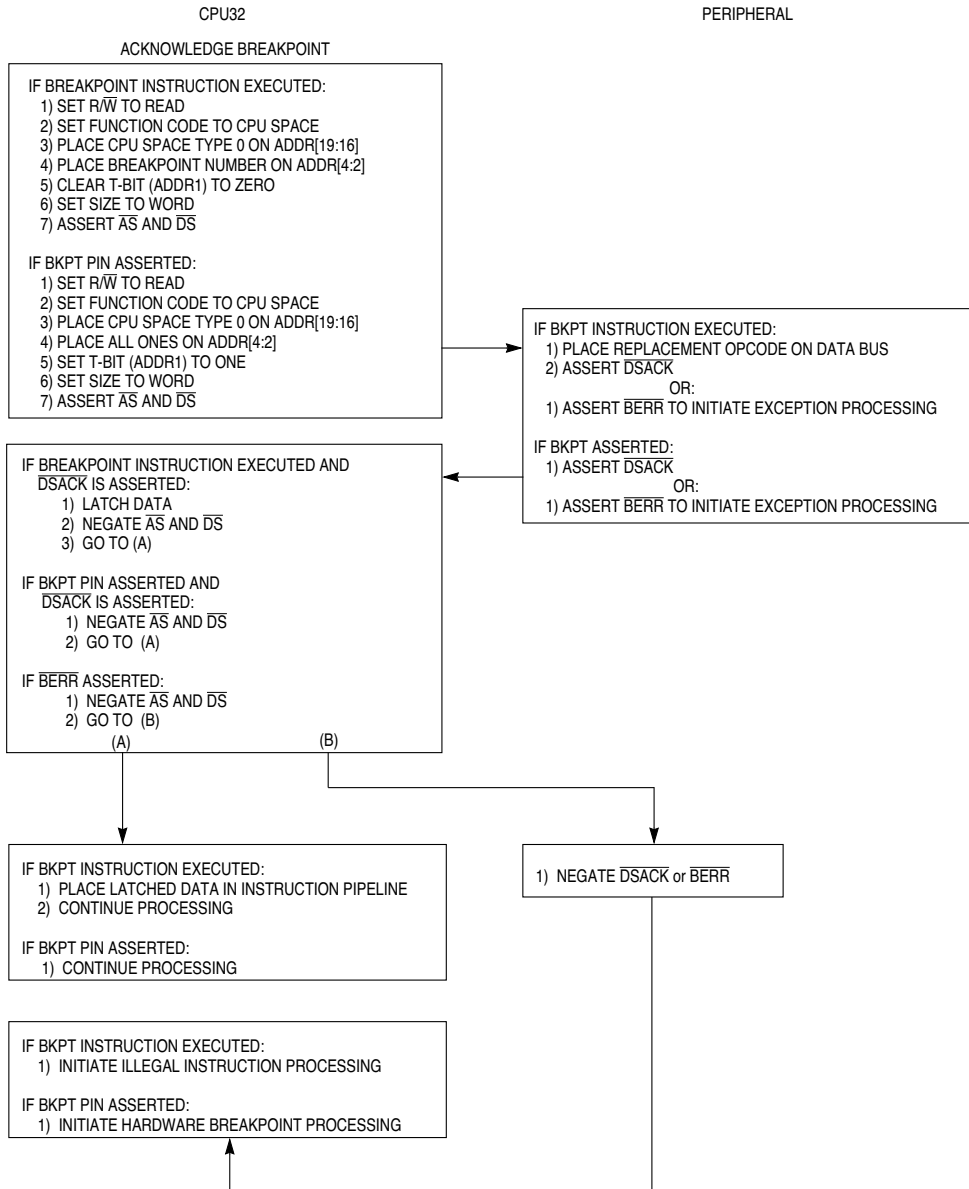

BREAKPOINT OPERATION FLOW

Figure 5-13 Breakpoint Operation Flowchart

### 5.6.4.2 LPSTOP Broadcast Cycle

Low-power stop mode is initiated by the CPU32. Individual modules can be stopped by setting the STOP bits in each module configuration register, or the SIM can turn off system clocks after execution of the LPSTOP instruction. When the CPU32 executes LPSTOP, an LPSTOP broadcast cycle is generated. The SIM brings the MCU out of low-power stop mode when either an interrupt of higher priority than the stored mask or a reset occurs. Refer to **5.3.4 Low-Power Operation** and **4.8.2.1 Low-Power Stop (LPSTOP)** for more information.

During an LPSTOP broadcast cycle, the CPU32 performs a CPU space write to address \$3FFFE. This write puts a copy of the interrupt mask value in the clock control logic. The mask is encoded on the data bus as shown in **Figure 5-14**. The LPSTOP CPU space cycle is shown externally (if the bus is available) as an indication to external devices that the MCU is going into low-power stop mode. The SIM provides an internally generated  $\overline{DSACK}$  response to this cycle. The timing of this bus cycle is the same as for a fast termination write cycle. If the bus is not available (arbitrated away), the LPSTOP broadcast cycle is not shown externally.

#### NOTE

$\overline{BERR}$  during the LPSTOP broadcast cycle is ignored.

15	14	13	12	11	10	9	8	7	6	5	4	3	2	1	0
0	0	0	0	0	0	0	0	0	0	0	0	0	0	0	IP MASK

LPSTOP MASK LEVEL

**Figure 5-14 LPSTOP Interrupt Mask Level**

### 5.6.5 Bus Exception Control Cycles

An external device or a chip-select circuit must assert at least one of the  $\overline{DSACK}[1:0]$  signals or the  $\overline{AVEC}$  signal to terminate a bus cycle normally. Bus error processing occurs when bus cycles are not terminated in the expected manner. The SIM bus monitor can be used to generate  $\overline{BERR}$  internally, causing a bus error exception to be taken. Bus cycles can also be terminated by assertion of the external  $\overline{BERR}$  or  $\overline{HALT}$  pins signal, or by assertion of the two signals simultaneously.

Acceptable bus cycle termination sequences are summarized as follows. The case numbers refer to **Table 5-13**, which indicates the results of each type of bus cycle termination.

- Normal Termination
  - $\overline{DSACK}$  is asserted;  $\overline{BERR}$  and  $\overline{HALT}$  remain negated (case 1).
- Halt Termination
  - $\overline{HALT}$  is asserted at the same time or before  $\overline{DSACK}$ , and  $\overline{BERR}$  remains negated (case 2).



- Bus Error Termination
  - $\overline{\text{BERR}}$  is asserted in lieu of, at the same time as, or before  $\overline{\text{DSACK}}$  (case 3), or after  $\overline{\text{DSACK}}$  (case 4), and  $\overline{\text{HALT}}$  remains negated;  $\overline{\text{BERR}}$  is negated at the same time or after  $\overline{\text{DSACK}}$ .
- Retry Termination
  - $\overline{\text{HALT}}$  and  $\overline{\text{BERR}}$  are asserted in lieu of, at the same time as, or before  $\overline{\text{DSACK}}$  (case 5) or after  $\overline{\text{DSACK}}$  (case 6);  $\overline{\text{BERR}}$  is negated at the same time or after  $\overline{\text{DSACK}}$ ;  $\overline{\text{HALT}}$  may be negated at the same time or after  $\overline{\text{BERR}}$ .

**Table 5-13** shows various combinations of control signal sequences and the resulting bus cycle terminations.

**Table 5-13  $\overline{\text{DSACK}}$ ,  $\overline{\text{BERR}}$ , and  $\overline{\text{HALT}}$  Assertion Results**

Case Number	Control Signal	Asserted on Rising Edge of State		Result
		N <sup>1</sup>	N + 2	
1	$\overline{\text{DSACK}}$ $\overline{\text{BERR}}$ $\overline{\text{HALT}}$	A <sup>2</sup> NA <sup>3</sup> NA	S <sup>4</sup> NA X <sup>5</sup>	Normal termination.
2	$\overline{\text{DSACK}}$ $\overline{\text{BERR}}$ $\overline{\text{HALT}}$	A NA A/S	S NA S	Halt termination: normal cycle terminate and halt. Continue when $\overline{\text{HALT}}$ is negated.
3	$\overline{\text{DSACK}}$ $\overline{\text{BERR}}$ $\overline{\text{HALT}}$	NA/A A NA	X S X	Bus error termination: terminate and take bus error exception, possibly deferred.
4	$\overline{\text{DSACK}}$ $\overline{\text{BERR}}$ $\overline{\text{HALT}}$	A A NA	X S NA	Bus error termination: terminate and take bus error exception, possibly deferred.
5	$\overline{\text{DSACK}}$ $\overline{\text{BERR}}$ $\overline{\text{HALT}}$	NA/A A A/S	X S S	Retry termination: terminate and retry when $\overline{\text{HALT}}$ is negated.
6	$\overline{\text{DSACK}}$ $\overline{\text{BERR}}$ $\overline{\text{HALT}}$	A NA NA	X A A	Retry termination: terminate and retry when $\overline{\text{HALT}}$ is negated.

NOTES:

1. N = The number of current even bus state (S2, S4, etc.).
2. A = Signal is asserted in this bus state.
3. NA = Signal is not asserted in this state.
4. X = Don't care.
5. S = Signal was asserted in previous state and remains asserted in this state.

To control termination of a bus cycle for a retry or a bus error condition properly,  $\overline{\text{DSACK}}$ ,  $\overline{\text{BERR}}$ , and  $\overline{\text{HALT}}$  must be asserted and negated with the rising edge of the MCU clock. This ensures that when two signals are asserted simultaneously, the required setup time and hold time for both of them are met for the same falling edge of the MCU clock. Refer to **APPENDIX A ELECTRICAL CHARACTERISTICS** for timing requirements. External circuitry that provides these signals must be designed with these constraints in mind, or else the internal bus monitor must be used.

$\overline{\text{DSACK}}$ ,  $\overline{\text{BERR}}$ , and  $\overline{\text{HALT}}$  may be negated after  $\overline{\text{AS}}$  is negated.

## WARNING

If  $\overline{\text{DSACK}}$  or  $\overline{\text{BERR}}$  remain asserted into S2 of the next bus cycle, that cycle may be terminated prematurely.

### 5.6.5.1 Bus Errors

The CPU32 treats bus errors as a type of exception. Bus error exception processing begins when the CPU32 detects assertion of the IMB  $\overline{\text{BERR}}$  signal (by the internal bus monitor or an external source) while the  $\overline{\text{HALT}}$  signal remains negated.

$\overline{\text{BERR}}$  assertions do not force immediate exception processing. The signal is synchronized with normal bus cycles and is latched into the CPU32 at the end of the bus cycle in which it was asserted. Because bus cycles can overlap instruction boundaries, bus error exception processing may not occur at the end of the instruction in which the bus cycle begins. Timing of  $\overline{\text{BERR}}$  detection/acknowledge is dependent upon several factors:

- Which bus cycle of an instruction is terminated by assertion of  $\overline{\text{BERR}}$ .
- The number of bus cycles in the instruction during which  $\overline{\text{BERR}}$  is asserted.
- The number of bus cycles in the instruction following the instruction in which  $\overline{\text{BERR}}$  is asserted.
- Whether  $\overline{\text{BERR}}$  is asserted during a program space access or a data space access.

Because of these factors, it is impossible to predict precisely how long after occurrence of a bus error the bus error exception is processed.

## CAUTION

The external bus interface does not latch data when an external bus cycle is terminated by a bus error. When this occurs during an instruction prefetch, the IMB precharge state (bus pulled high, or \$FF) is latched into the CPU32 instruction register, with indeterminate results.

### 5.6.5.2 Double Bus Faults

Exception processing for bus error exceptions follows the standard exception processing sequence. Refer to **4.9 Exception Processing** for more information. However, a special case of bus error, called double bus fault, can abort exception processing.

$\overline{\text{BERR}}$  assertion is not detected until an instruction is complete. The  $\overline{\text{BERR}}$  latch is cleared by the first instruction of the  $\overline{\text{BERR}}$  exception handler. Double bus fault occurs in three ways:

1. When bus error exception processing begins and a second  $\overline{\text{BERR}}$  is detected before the first instruction of the exception handler is executed.
2. When one or more bus errors occur before the first instruction after a reset exception is executed.
3. A bus error occurs while the CPU32 is loading information from a bus error stack frame during a return from exception (RTE) instruction.

Multiple bus errors within a single instruction that can generate multiple bus cycles cause a single bus error exception after the instruction has been executed.

Immediately after assertion of a second  $\overline{\text{BERR}}$ , the MCU halts and drives the  $\overline{\text{HALT}}$  line low. Only a reset can restart a halted MCU. However, bus arbitration can still occur. Refer to **5.6.6 External Bus Arbitration** for more information. A bus error or address error that occurs after exception processing has been completed (during the execution of the exception handler routine, or later) does not cause a double bus fault. The MCU continues to retry the same bus cycle as long as the external hardware requests it.

### 5.6.5.3 Retry Operation

When an external device asserts  $\overline{\text{BERR}}$  and  $\overline{\text{HALT}}$  during a bus cycle, the MCU enters the retry sequence. A delayed retry can also occur. The MCU terminates the bus cycle, places the  $\overline{\text{AS}}$  and  $\overline{\text{DS}}$  signals in their inactive state, and does not begin another bus cycle until the  $\overline{\text{BERR}}$  and  $\overline{\text{HALT}}$  signals are negated by external logic. After a synchronization delay, the MCU retries the previous cycle using the same address, function codes, data (for a write), and control signals. The  $\overline{\text{BERR}}$  signal should be negated before S2 of the read cycle to ensure correct operation of the retried cycle.

If  $\overline{\text{BR}}$ ,  $\overline{\text{BERR}}$ , and  $\overline{\text{HALT}}$  are all asserted on the same cycle, the EBI will enter the rerun sequence but first relinquishes the bus to an external master. Once the external master returns the bus and negates  $\overline{\text{BERR}}$  and  $\overline{\text{HALT}}$ , the EBI runs the previous bus cycle. This feature allows an external device to correct the problem that caused the bus error and then try the bus cycle again.

The MCU retries any read or write cycle of an indivisible read-modify-write operation separately.  $\overline{\text{RMC}}$  remains asserted during the entire retry sequence. The MCU will not relinquish the bus while  $\overline{\text{RMC}}$  is asserted. Any device that requires the MCU to give up the bus and retry a bus cycle during a read-modify-write cycle must assert  $\overline{\text{BERR}}$  and  $\overline{\text{BR}}$  only ( $\overline{\text{HALT}}$  must remain negated). The bus error handler software should examine the read-modify-write bit in the special status word and take the appropriate action to resolve this type of fault when it occurs. Refer to the *SIM Reference Manual* (SIMRM/AD) for additional information on read-modify-write and retry operations.

### 5.6.5.4 Halt Operation

When  $\overline{\text{HALT}}$  is asserted while  $\overline{\text{BERR}}$  is not asserted, the MCU halts external bus activity after negation of  $\overline{\text{DSACK}}$ . The MCU may complete the current word transfer in progress. For a long-word to byte transfer, this could be after S2 or S4. For a word to byte transfer, activity ceases after S2.

Negating and reasserting  $\overline{\text{HALT}}$  according to timing requirements provides single-step (bus cycle to bus cycle) operation. The  $\overline{\text{HALT}}$  signal affects external bus cycles only, so that a program that does not use the external bus can continue executing.

During dynamically-sized 8-bit transfers, external bus activity may not stop at the next cycle boundary. Occurrence of a bus error while  $\overline{\text{HALT}}$  is asserted causes the CPU32 to initiate a retry sequence.

When the MCU completes a bus cycle while the  $\overline{\text{HALT}}$  signal is asserted, the data bus goes into a high-impedance state and the  $\overline{\text{AS}}$  and  $\overline{\text{DS}}$  signals are driven to their inactive states. Address, function code, size, and read/write signals remain in the same state.

The halt operation has no effect on bus arbitration. However, when external bus arbitration occurs while the MCU is halted, address and control signals go into a high-impedance state. If  $\overline{\text{HALT}}$  is still asserted when the MCU regains control of the bus, address, function code, size, and read/write signals revert to the previous driven states. The MCU cannot service interrupt requests while halted.

### 5.6.6 External Bus Arbitration

The MCU bus design provides for a single bus master at any one time. Either the MCU or an external device can be master. Bus arbitration protocols determine when an external device can become bus master. Bus arbitration requests are recognized during normal processing,  $\overline{\text{HALT}}$  assertion, and when the CPU32 has halted due to a double bus fault.

The bus controller in the MCU manages bus arbitration signals so that the MCU has the lowest priority. External devices that need to obtain the bus must assert bus arbitration signals in the sequences described in the following paragraphs.

Systems that include several devices that can become bus master require external circuitry to assign priorities to the devices, so that when two or more external devices attempt to become bus master at the same time, the one having the highest priority becomes bus master first. The protocol sequence is:

1. An external device asserts the bus request signal ( $\overline{\text{BR}}$ );
2. The MCU asserts the bus grant signal ( $\overline{\text{BG}}$ ) to indicate that the bus is available;
3. An external device asserts the bus grant acknowledge ( $\overline{\text{BGACK}}$ ) signal to indicate that it has assumed bus mastership.

$\overline{\text{BR}}$  can be asserted during a bus cycle or between cycles.  $\overline{\text{BG}}$  is asserted in response to  $\overline{\text{BR}}$ . To guarantee operand coherency,  $\overline{\text{BG}}$  is only asserted at the end of operand transfer. Additionally,  $\overline{\text{BG}}$  is not asserted until the end of an indivisible read-modify-write operation (when  $\overline{\text{RMC}}$  is negated).

If more than one external device can be bus master, required external arbitration must begin when a requesting device receives  $\overline{\text{BG}}$ . An external device must assert  $\overline{\text{BGACK}}$  when it assumes mastership, and must maintain  $\overline{\text{BGACK}}$  assertion as long as it is bus master.

Two conditions must be met for an external device to assume bus mastership. The device must receive  $\overline{\text{BG}}$  through the arbitration process, and  $\overline{\text{BGACK}}$  must be inactive, indicating that no other bus master is active. This technique allows the processing of bus requests during data transfer cycles.

$\overline{\text{BG}}$  is negated a few clock cycles after  $\overline{\text{BGACK}}$  transition. However, if bus requests are still pending after  $\overline{\text{BG}}$  is negated, the MCU asserts  $\overline{\text{BG}}$  again within a few clock cycles.

This additional  $\overline{BG}$  assertion allows external arbitration circuitry to select the next bus master before the current master has released the bus.

Refer to **Figure 5-15**, which shows bus arbitration for a single device. The flowchart shows  $\overline{BR}$  negated at the same time  $\overline{BGACK}$  is asserted.

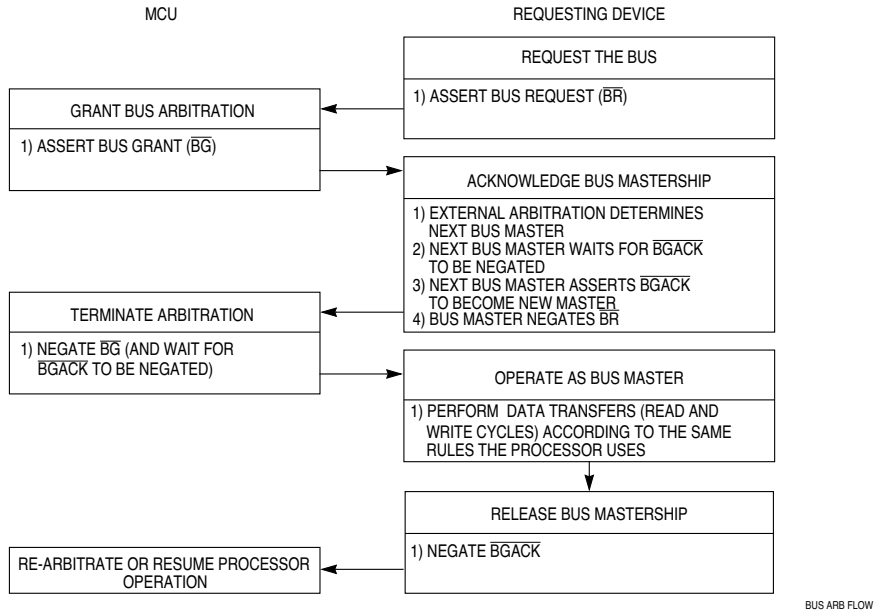

**Figure 5-15 Bus Arbitration Flowchart for Single Request**

### 5.6.6.1 Show Cycles

The MCU normally performs internal data transfers without affecting the external bus, but it is possible to show these transfers during debugging.  $\overline{AS}$  is not asserted externally during show cycles.

Show cycles are controlled by SHEN[1:0] in SIMCR. This field is set to %00 by reset. When show cycles are disabled, the address bus, function codes, size, and read/write signals reflect internal bus activity, but  $\overline{AS}$  and  $\overline{DS}$  are not asserted externally and external data bus pins are in high-impedance state during internal accesses. Refer to **5.2.3 Show Internal Cycles** and the *SIM Reference Manual (SIMRM/AD)* for more information.

When show cycles are enabled,  $\overline{DS}$  is asserted externally during internal cycles, and internal data is driven out on the external data bus. Because internal cycles normally continue to run when the external bus is granted, one SHEN encoding halts internal bus activity while there is an external master.

SIZ[1:0] signals reflect bus allocation during show cycles. Only the appropriate portion of the data bus is valid during the cycle. During a byte write to an internal address, the portion of the bus that represents the byte that is not written reflects internal bus conditions, and is indeterminate. During a byte write to an external address, the data multiplexer in the SIM causes the value of the byte that is written to be driven out on both bytes of the data bus.

## 5.7 Reset

Reset occurs when an active low logic level on the  $\overline{\text{RESET}}$  pin is clocked into the SIM. The  $\overline{\text{RESET}}$  input is synchronized to the system clock. If there is no clock when  $\overline{\text{RESET}}$  is asserted, reset does not occur until the clock starts. Resets are clocked to allow completion of write cycles in progress at the time  $\overline{\text{RESET}}$  is asserted.

Reset procedures handle system initialization and recovery from catastrophic failure. The MCU performs resets with a combination of hardware and software. The SIM determines whether a reset is valid, asserts control signals, performs basic system configuration and boot ROM selection based on hardware mode-select inputs, then passes control to the CPU32.

### 5.7.1 Reset Exception Processing

The CPU32 processes resets as a type of asynchronous exception. An exception is an event that preempts normal processing, and can be caused by internal or external events. Exception processing makes the transition from normal instruction execution to execution of a routine that deals with an exception. Each exception has an assigned vector that points to an associated handler routine. These vectors are stored in the exception vector table. The exception vector table consists of 256 four-byte vectors and occupies 1024 bytes of address space. The exception vector table can be relocated in memory by changing its base address in the vector base register (VBR). The CPU32 uses vector numbers to calculate displacement into the table. Refer to **4.9 Exception Processing** for more information.

Reset is the highest-priority CPU32 exception. Unlike all other exceptions, a reset occurs at the end of a bus cycle, and not at an instruction boundary. Handling resets in this way prevents write cycles in progress at the time the reset signal is asserted from being corrupted. However, any processing in progress is aborted by the reset exception and cannot be restarted. Only essential reset tasks are performed during exception processing. Other initialization tasks must be accomplished by the exception handler routine. Refer to **5.7.9 Reset Processing Summary** for details on exception processing.

### 5.7.2 Reset Control Logic

SIM reset control logic determines the cause of a reset, synchronizes reset assertion if necessary to the completion of the current bus cycle, and asserts the appropriate reset lines. Reset control logic can drive four different internal signals:

1. XTRST (external reset) drives the external reset pin.
2. CLKRST (clock reset) resets the clock module.
3. MSTRST (master reset) goes to all other internal circuits.
4. SYSRST (system reset) indicates to internal circuits that the CPU32 has executed a RESET instruction.

All resets are gated by CLKOUT. Resets are classified as synchronous or asynchronous. An asynchronous reset can occur on any CLKOUT edge. Reset sources that cause an asynchronous reset usually indicate a catastrophic failure. As a result, the reset control logic responds by asserting reset to the system immediately. (A system reset, however, caused by the CPU32 RESET instruction, is asynchronous but does not indicate any type of catastrophic failure).

Synchronous resets are timed to occur at the end of bus cycles. The SIM bus monitor is automatically enabled for synchronous resets. When a bus cycle does not terminate normally, the bus monitor terminates it.

Refer to **Table 5-14** for a summary of reset sources.

**Table 5-14 Reset Source Summary**

Type	Source	Timing	Cause	Reset Lines Asserted by Controller		
External	External	Synch	RESET pin	MSTRST	CLKRST	EXTRST
Power up	EBI	Asynch	V <sub>DD</sub>	MSTRST	CLKRST	EXTRST
Software watchdog	Monitor	Asynch	Time out	MSTRST	CLKRST	EXTRST
HALT	Monitor	Asynch	Internal HALT assertion (e.g. double bus fault)	MSTRST	CLKRST	EXTRST
Loss of clock	Clock	Synch	Loss of reference	MSTRST	CLKRST	EXTRST
Test	Test	Synch	Test mode	MSTRST	—	EXTRST
System	CPU32	Asynch	RESET instruction	—	—	EXTRST

Internal single byte or aligned word writes are guaranteed valid for synchronous resets. External writes are also guaranteed to complete, provided the external configuration logic on the data bus is conditioned as shown in **Figure 5-16**.

### 5.7.3 Reset Mode Selection

The logic states of certain data bus pins during reset determine SIM operating configuration. In addition, the state of the MODCLK pin determines system clock source and the state of the BKPT pin determines what happens during subsequent breakpoint assertions. **Table 5-15** is a summary of reset mode selection options.

**Table 5-15 Reset Mode Selection**

Mode Select Pin	Default Function (Pin Left High)	Alternate Function (Pin Pulled Low)
DATA0	CSBOOT 16-bit	CSBOOT 8-bit
DATA1	CS0 CS1 CS2	BR BG BGACK
DATA2	CS3 CS4 CS5	FC0 FC1 FC2
DATA3 DATA4 DATA5 DATA6 DATA7	CS6 CS[7:6] CS[8:6] CS[9:6] CS[10:6]	ADDR19 ADDR[20:19] ADDR[21:19] ADDR[22:19] ADDR[23:19]
DATA8	DSACK[1:0], AVEC, DS, AS, SIZ[1:0]	PORTE
DATA9	IRQ[7:1] MODCLK	PORTF
DATA11	Normal operation <sup>1</sup>	Reserved
MODCLK	VCO = System clock	EXTAL = System clock
BKPT	Background mode disabled	Background mode enabled

NOTES:

1. The DATA11 bus must remain high during reset to ensure normal operation.

### 5.7.3.1 Data Bus Mode Selection

All data lines have weak internal pull-up drivers. When pins are held high by the internal drivers, the MCU uses a default operating configuration. However, specific lines can be held low externally during reset to achieve an alternate configuration.

#### NOTE

External bus loading can overcome the weak internal pull-up drivers on data bus lines and hold pins low during reset.

Use an active device to hold data bus lines low. Data bus configuration logic must release the bus before the first bus cycle after reset to prevent conflict with external memory devices. The first bus cycle occurs ten CLKOUT cycles after  $\overline{\text{RESET}}$  is released. If external mode selection logic causes a conflict of this type, an isolation resistor on the driven lines may be required. **Figure 5-16** shows a recommended method for conditioning the mode select signals.

The mode configuration drivers are conditioned with  $R/\overline{W}$  and  $\overline{\text{DS}}$  to prevent conflicts between external devices and the MCU when reset is asserted. If external  $\overline{\text{RESET}}$  is asserted during an external write cycle,  $R/\overline{W}$  conditioning (as shown in **Figure 5-16**) prevents corruption of the data during the write. Similarly,  $\overline{\text{DS}}$  conditions the mode configuration drivers so that external reads are not corrupted when  $\overline{\text{RESET}}$  is asserted during an external read cycle.



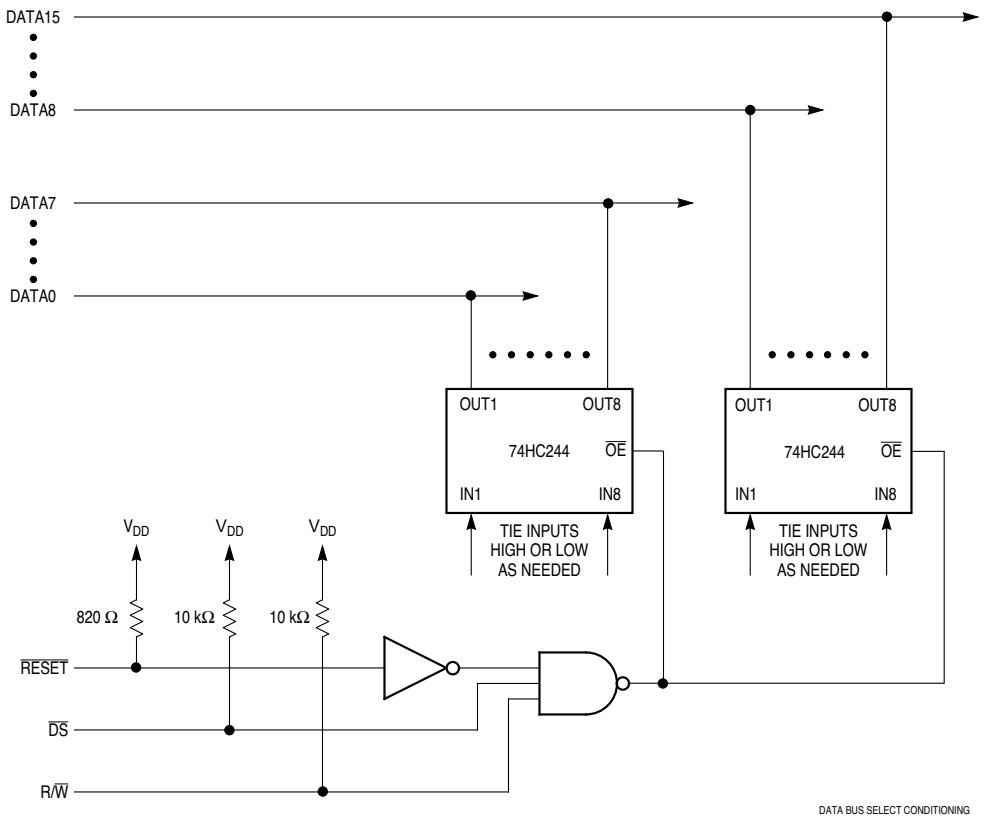

**Figure 5-16 Preferred Circuit for Data Bus Mode Select Conditioning**

Alternate methods can be used for driving data bus pins low during reset. **Figure 5-17** shows two of these options. The simplest is to connect a resistor in series with a diode from the data bus pin to the  $\overline{\text{RESET}}$  line. A bipolar transistor can be used for the same purpose, but an additional current limiting resistor must be connected between the base of the transistor and the  $\overline{\text{RESET}}$  pin. If a MOSFET is substituted for the bipolar transistor, only the 1 k $\Omega$  isolation resistor is required. These simpler circuits do not offer the protection from potential memory corruption during  $\overline{\text{RESET}}$  assertion as does the circuit shown in **Figure 5-16**.

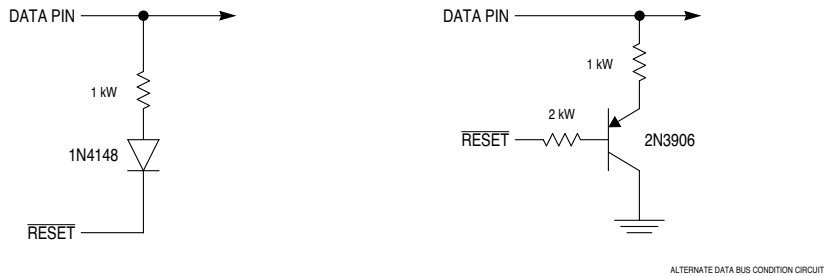

**Figure 5-17 Alternate Circuit for Data Bus Mode Select Conditioning**

Data bus mode select current is specified in **Table A-5**. Do not confuse pin function with pin electrical state. Refer to **5.7.5 Pin States During Reset** for more information.

Unlike other chip-select signals, the boot ROM chip-select ( $\overline{CSBOOT}$ ) is active at the release of  $\overline{RESET}$ . During reset exception processing, the MCU fetches initialization vectors beginning at address \$000000 in supervisor program space. An external memory device containing vectors located at these addresses can be enabled by  $\overline{CSBOOT}$  after a reset.

The logic level of DATA0 during reset selects boot ROM port size for dynamic bus allocation. When DATA0 is held low, port size is eight bits; when DATA0 is held high, either by the weak internal pull-up driver or by an external pull-up, port size is 16 bits. Refer to **5.9.4 Chip-Select Reset Operation** for more information.

DATA1 and DATA2 determine the functions of  $\overline{CS}[2:0]$  and  $\overline{CS}[5:3]$ , respectively. DATA[7:3] determine the functions of an associated chip-select and all lower-numbered chip-selects down through  $\overline{CS}6$ . For example, if DATA5 is pulled low during reset,  $\overline{CS}[8:6]$  are assigned alternate function as ADDR[21:19], and  $\overline{CS}[10:9]$  remain chip-selects. Refer to **5.9.4 Chip-Select Reset Operation** for more information.

DATA8 determines the function of the  $\overline{DSACK}[1:0]$ ,  $\overline{AVEC}$ ,  $\overline{DS}$ ,  $\overline{AS}$ , and SIZE pins. If DATA8 is held low during reset, these pins are assigned to I/O port E.

DATA9 determines the function of interrupt request pins  $\overline{IRQ}[7:1]$  and the clock mode select pin (MODCLK). When DATA9 is held low during reset, these pins are assigned to I/O port F.

### 5.7.3.2 Clock Mode Selection

The state of the clock mode (MODCLK) pin during reset determines what clock source the MCU uses. When MODCLK is held high during reset, the clock signal is generated from a reference frequency using the clock synthesizer. When MODCLK is held low during reset, the clock synthesizer is disabled, and an external system clock signal must be applied. Refer to **5.3 System Clock** for more information.

## NOTE

The MODCLK pin can also be used as parallel I/O pin PF0. To prevent inadvertent clock mode selection by logic connected to port F, use an active device to drive MODCLK during reset.

### 5.7.3.3 Breakpoint Mode Selection

Background debug mode (BDM) is enabled when the breakpoint ( $\overline{\text{BKPT}}$ ) pin is sampled at a logic level zero at the release of  $\overline{\text{RESET}}$ . Subsequent assertion of the  $\overline{\text{BKPT}}$  pin or the internal breakpoint signal (for instance, the execution of the CPU32 BKPT instruction) will place the CPU32 in BDM.

If  $\overline{\text{BKPT}}$  is sampled at a logic level one at the rising edge of  $\overline{\text{RESET}}$ , BDM is disabled. Assertion of the  $\overline{\text{BKPT}}$  pin or execution of the execution of the BKPT instruction will result in normal breakpoint exception processing.

BDM remains enabled until the next system reset.  $\overline{\text{BKPT}}$  is relatched on each rising transition of  $\overline{\text{RESET}}$ .  $\overline{\text{BKPT}}$  is internally synchronized and must be held low for at least two clock cycles prior to  $\overline{\text{RESET}}$  negation for BDM to be enabled.  $\overline{\text{BKPT}}$  assertion logic must be designed with special care. If  $\overline{\text{BKPT}}$  assertion extends into the first bus cycle following the release of  $\overline{\text{RESET}}$ , the bus cycle could inadvertently be tagged with a breakpoint.

Refer to **4.10.2 Background Debug Mode** and the *CPU32 Reference Manual* (CPU32RM/AD) for more information on background debug mode. Refer to the *SIM Reference Manual* (SIMRM/AD) and **APPENDIX A ELECTRICAL CHARACTERISTICS** for more information concerning BKPT signal timing.

### 5.7.4 MCU Module Pin Function During Reset

Usually, module pins default to port functions and input/output ports are set to the input state. This is accomplished by disabling pin functions in the appropriate control registers, and by clearing the appropriate port data direction registers. Refer to individual module sections in this manual for more information. **Table 5-16** is a summary of module pin function out of reset.

**Table 5-16 Module Pin Functions During Reset**

Module	Pin Mnemonic	Function
CPU32	DSI/IFETCH	DSI/IFETCH
	DSO/IPIPE	DSO/IPIPE
	BKPT/DSCLK	BKPT/DSCLK
CTM4	CPWM[8:5]	Discrete output
	CTD[10:9]/[4:3]	Discrete input
	CTM4C	Discrete input
QADC	PQA[7:5]/AN[59:57]	Discrete input
	PQA[4:3]/AN[56:55]/ETRIG[2:1]	Discrete input
	PQA[2:0]/AN[54:52]/MA[2:0]	Discrete input
	PQB[7:4]/AN[51:48]	Discrete input
	PQB[3:0]/AN[z, y, x, w]/AN[3:0]	Discrete input
QSM	PQS0/MISO	Discrete input
	PQS1/MOSI	Discrete input
	PQS2/SCK	Discrete input
	PQS3/PCS0/SS	Discrete input
	PQS[6:4]/PCS[3:1]	RXD
	PQS7/TXD	Discrete input
	RXD	Discrete input
TouCAN (MC68376 only)	CANRX0	TouCAN receive
	CANTX0	TouCAN transmit
TPU	TPUCH[15:0]	TPU input
	T2CLK	TCR2 clock

### 5.7.5 Pin States During Reset

It is important to keep the distinction between pin function and pin electrical state clear. Although control register values and mode select inputs determine pin function, a pin driver can be active, inactive or in high-impedance state while reset occurs. During power-on reset, pin state is subject to the constraints discussed in **5.7.7 Power-On Reset**.

#### NOTE

Pins that are not used should either be configured as outputs, or (if configured as inputs) pulled to the appropriate inactive state. This decreases additional  $I_{DD}$  caused by digital inputs floating near mid-supply level.

#### 5.7.5.1 Reset States of SIM Pins

Generally, while  $\overline{RESET}$  is asserted, SIM pins either go to an inactive high-impedance state or are driven to their inactive states. After  $\overline{RESET}$  is released, mode selection occurs and reset exception processing begins. Pins configured as inputs must be driven to the desired active state. Pull-up or pull-down circuitry may be necessary. Pins configured as outputs begin to function after  $\overline{RESET}$  is released. **Table 5-17** is a summary of SIM pin states during reset.

**Table 5-17 SIM Pin Reset States**

Pin(s)	Pin State While $\overline{\text{RESET}}$ Asserted	Pin State After $\overline{\text{RESET}}$ Released			
		Default Function		Alternate Function	
		Pin Function	Pin State	Pin Function	Pin State
CS10/ADDR23/ECLK	$V_{DD}$	$\overline{\text{CS}}10$	$V_{DD}$	ADDR23	Unknown
CS[9:6]/ADDR[22:19]/PC[6:3]	$V_{DD}$	CS[9:6]	$V_{DD}$	ADDR[22:19]	Unknown
ADDR[18:0]	High-Z	ADDR[18:0]	Unknown	ADDR[18:0]	Unknown
$\overline{\text{AS}}/\text{PE}5$	High-Z	$\overline{\text{AS}}$	Output	PE5	Input
$\overline{\text{AVEC}}/\text{PE}2$	High-Z	$\overline{\text{AVEC}}$	Input	PE2	Input
$\overline{\text{BERR}}$	High-Z	$\overline{\text{BERR}}$	Input	$\overline{\text{BERR}}$	Input
CS1/BG	$V_{DD}$	CS1	$V_{DD}$	BG	$V_{DD}$
CS2/BGACK	$V_{DD}$	CS2	$V_{DD}$	BGACK	Input
CS0/BR	$V_{DD}$	CS0	$V_{DD}$	BR	Input
CLKOUT	Output	CLKOUT	Output	CLKOUT	Output
CSBOOT	$V_{DD}$	$\overline{\text{CSBOOT}}$	$V_{SS}$	$\overline{\text{CSBOOT}}$	$V_{SS}$
DATA[15:0]	Mode select	DATA[15:0]	Input	DATA[15:0]	Input
DS/PE4	High-Z	DS	Output	PE4	Input
$\overline{\text{DSACK}}0/\text{PE}0$	High-Z	$\overline{\text{DSACK}}0$	Input	PE0	Input
$\overline{\text{DSACK}}1/\text{PE}1$	High-Z	$\overline{\text{DSACK}}1$	Input	PE1	Input
CS[5:3]/FC[2:0]/PC[2:0]	$V_{DD}$	CS[5:3]	$V_{DD}$	FC[2:0]	Unknown
$\overline{\text{HALT}}$	High-Z	$\overline{\text{HALT}}$	Input	$\overline{\text{HALT}}$	Input
$\overline{\text{IRQ}}[7:1]/\text{PF}[7:1]$	High-Z	$\overline{\text{IRQ}}[7:1]$	Input	$\overline{\text{PF}}[7:1]$	Input
MODCLK/PF0	Mode Select	MODCLK	Input	PF0	Input
R/W	High-Z	$\overline{\text{R/W}}$	Output	$\overline{\text{R/W}}$	Output
$\overline{\text{RESET}}$	Asserted	$\overline{\text{RESET}}$	Input	$\overline{\text{RESET}}$	Input
RMC/PE3	High-Z	RMC	Output	PE3	Input
SIZ[1:0]/PE[7:6]	High-Z	SIZ[1:0]	Unknown	PE[7:6]	Input
$\overline{\text{TSTME}}/\text{TSC}$	Mode select	TSC	Input	TSC	Input

### 5.7.5.2 Reset States of Pins Assigned to Other MCU Modules

As a rule, module pins that are assigned to general-purpose I/O ports go into a high-impedance state following reset. Other pin states are determined by individual module control register settings. Refer to sections concerning modules for details. However, during power-on reset, module port pins may be in an indeterminate state for a short period. Refer to **5.7.7 Power-On Reset** for more information.

### 5.7.6 Reset Timing

The  $\overline{\text{RESET}}$  input must be asserted for a specified minimum period for reset to occur. External  $\overline{\text{RESET}}$  assertion can be delayed internally for a period equal to the longest bus cycle time (or the bus monitor time-out period) in order to protect write cycles from being aborted by reset. While  $\overline{\text{RESET}}$  is asserted, SIM pins are either in an inactive, high-impedance state or are driven to their inactive states.

When an external device asserts  $\overline{\text{RESET}}$  for the proper period, reset control logic clocks the signal into an internal latch. The control logic drives the  $\overline{\text{RESET}}$  pin low for an additional 512 CLKOUT cycles after it detects that the  $\overline{\text{RESET}}$  signal is no longer being externally driven to guarantee this length of reset to the entire system.

If an internal source asserts a reset signal, the reset control logic asserts the  $\overline{\text{RESET}}$  pin for a minimum of 512 cycles. If the reset signal is still asserted at the end of 512 cycles, the control logic continues to assert the  $\overline{\text{RESET}}$  pin until the internal reset signal is negated.

After 512 cycles have elapsed, the  $\overline{\text{RESET}}$  pin goes to an inactive, high-impedance state for ten cycles. At the end of this 10-cycle period, the  $\overline{\text{RESET}}$  input is tested. When the input is at logic level one, reset exception processing begins. If, however, the  $\overline{\text{RESET}}$  input is at logic level zero, reset control logic drives the pin low for another 512 cycles. At the end of this period, the pin again goes to high-impedance state for ten cycles, then it is tested again. The process repeats until  $\overline{\text{RESET}}$  is released.

### 5.7.7 Power-On Reset

When the SIM clock synthesizer is used to generate system clocks, power-on reset involves special circumstances related to application of system and clock synthesizer power. Regardless of clock source, voltage must be applied to the clock synthesizer power input pin  $V_{\text{DDSYN}}$  for the MCU to operate. The following discussion assumes that  $V_{\text{DDSYN}}$  is applied before and during reset, which minimizes crystal start-up time. When  $V_{\text{DDSYN}}$  is applied at power-on, start-up time is affected by specific crystal parameters and by oscillator circuit design.  $V_{\text{DD}}$  ramp-up time also affects pin state during reset. Refer to **APPENDIX A ELECTRICAL CHARACTERISTICS** for voltage and timing specifications.

During power-on reset, an internal circuit in the SIM drives the IMB internal (MSTRST) and external (EXTRST) reset lines. The power-on reset circuit releases the internal reset line as  $V_{\text{DD}}$  ramps up to the minimum operating voltage, and SIM pins are initialized to the values shown in **Table 5-17**. When  $V_{\text{DD}}$  reaches the minimum operating voltage, the clock synthesizer VCO begins operation. Clock frequency ramps up to specified limp mode frequency ( $f_{\text{limp}}$ ). The external  $\overline{\text{RESET}}$  line remains asserted until the clock synthesizer PLL locks and 512 CLKOUT cycles elapse.

The SIM clock synthesizer provides clock signals to the other MCU modules. After the clock is running and MSTRST is asserted for at least four clock cycles, these modules reset.  $V_{\text{DD}}$  ramp time and VCO frequency ramp time determine how long the four cycles take. Worst case is approximately 15 milliseconds. During this period, module port pins may be in an indeterminate state. While input-only pins can be put in a known state by external pull-up resistors, external logic on input/output or output-only pins during this time must condition the lines. Active drivers require high-impedance buffers or isolation resistors to prevent conflict.

**Figure 5-18** is a timing diagram for power-on reset. It shows the relationships between  $\overline{\text{RESET}}$ ,  $V_{\text{DD}}$ , and bus signals.

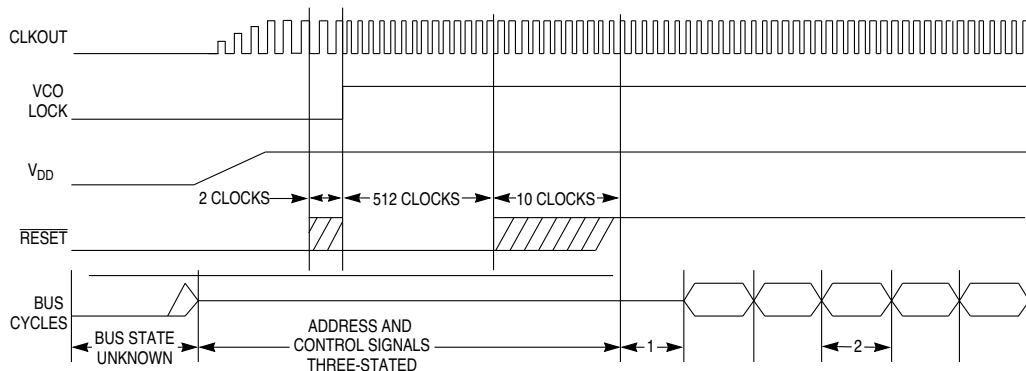

- NOTES:  
 1. INTERNAL START-UP TIME  
 2. FIRST INSTRUCTION FETCHED

32 POR TIM

**Figure 5-18 Power-On Reset**

### 5.7.8 Use of the Three-State Control Pin

Asserting the three-state control (TSC) input causes the MCU to put all output drivers in a disabled, high-impedance state. The signal must remain asserted for approximately ten clock cycles in order for drivers to change state.

When the internal clock synthesizer is used (MODCLK held high during reset), synthesizer ramp-up time affects how long the ten cycles take. Worst case is approximately 20 milliseconds from TSC assertion.

When an external clock signal is applied (MODCLK held low during reset), pins go to high-impedance state as soon after TSC assertion as approximately ten clock pulses have been applied to the EXTAL pin.

#### NOTE

When TSC assertion takes effect, internal signals are forced to values that can cause inadvertent mode selection. Once the output drivers change state, the MCU must be powered down and restarted before normal operation can resume.

### 5.7.9 Reset Processing Summary

To prevent write cycles in progress from being corrupted, a reset is recognized at the end of a bus cycle instead of at an instruction boundary. Any processing in progress at the time a reset occurs is aborted. After SIM reset control logic has synchronized an internal or external reset request, the MSTRST signal is asserted.

The following events take place when MSTRST is asserted:

- A. Instruction execution is aborted.
- B. The status register is initialized.
  - 1. The T0 and T1 bits are cleared to disable tracing.
  - 2. The S bit is set to establish supervisor privilege level.
  - 3. The interrupt priority mask is set to \$7, disabling all interrupts below priority 7.
- C. The vector base register is initialized to \$000000.

The following events take place when MSTRST is negated after assertion.

- A. The CPU32 samples the  $\overline{\text{BKPT}}$  input.
- B. The CPU32 fetches the reset vector:
  - 1. The first long word of the vector is loaded into the interrupt stack pointer.
  - 2. The second long word of the vector is loaded into the program counter.
  - 3. Vectors can be fetched from external ROM enabled by the  $\overline{\text{CSBOOT}}$  signal.
- C. The CPU32 fetches and begins decoding the first instruction to be executed.

### 5.7.10 Reset Status Register

The reset status register (RSR) contains a bit for each reset source in the MCU. When a reset occurs, a bit corresponding to the reset type is set. When multiple causes of reset occur at the same time, only one bit in RSR may be set. The reset status register is updated by the reset control logic when the  $\overline{\text{RESET}}$  signal is released. Refer to **D.2.4 Reset Status Register** for more information.

## 5.8 Interrupts

Interrupt recognition and servicing involve complex interaction between the SIM, the CPU32, and a device or module requesting interrupt service.

The following paragraphs provide an overview of the entire interrupt process. Chip-select logic can also be used to terminate the IACK cycle with either  $\overline{\text{AVEC}}$  or  $\overline{\text{DSACK}}$ . Refer to **5.9 Chip-Selects** for more information.

### 5.8.1 Interrupt Exception Processing

The CPU32 processes interrupts as a type of asynchronous exception. An exception is an event that preempts normal processing. Each exception has an assigned vector in an exception vector table that points to an associated handler routine. The CPU32 uses vector numbers to calculate displacement into the table. During exception processing, the CPU fetches the appropriate vector and executes the exception handler routine to which the vector points.



At the release of reset, the exception vector table is located beginning at address \$000000. This value can be changed by programming the vector base register (VBR) with a new value. Multiple vector tables can be used. Refer to **4.9 Exception Processing** for more information.

### 5.8.2 Interrupt Priority and Recognition

The CPU32 provides seven levels of interrupt priority (1-7), seven automatic interrupt vectors, and 200 assignable interrupt vectors. All interrupts with priorities less than seven can be masked by the interrupt priority (IP) field in status register.

#### NOTE

Exceptions such as “address error” are not interrupts and have no “level” associated. Exceptions cannot ever be masked.

There are seven interrupt request signals ( $\overline{\text{IRQ}}[7:1]$ ). These signals are used internally on the IMB, and have corresponding pins for external interrupt service requests. The CPU32 treats all interrupt requests as though they come from internal modules; external interrupt requests are treated as interrupt service requests from the SIM. Each of the interrupt request signals corresponds to an interrupt priority.  $\overline{\text{IRQ}}1$  has the lowest priority and  $\overline{\text{IRQ}}7$  the highest.

Interrupt recognition is determined by interrupt priority level and interrupt priority (IP) mask value. The interrupt priority mask consists of three bits in the CPU32 status register. Binary values %000 to %111 provide eight priority masks. Masks prevent an interrupt request of a priority less than or equal to the mask value from being recognized and processed.  $\overline{\text{IRQ}}7$ , however, is always recognized, even if the mask value is %111.

$\overline{\text{IRQ}}[7:1]$  are active-low level-sensitive inputs. The low on the pin must remain asserted until an interrupt acknowledge cycle corresponding to that level is detected.

$\overline{\text{IRQ}}7$  is transition-sensitive as well as level-sensitive: a level-7 interrupt is not detected unless a falling edge transition is detected on the  $\overline{\text{IRQ}}7$  line. This prevents redundant servicing and stack overflow. A non-maskable interrupt is generated each time  $\overline{\text{IRQ}}7$  is asserted as well as each time the priority mask is written while  $\overline{\text{IRQ}}7$  is asserted. If  $\overline{\text{IRQ}}7$  is asserted and the IP mask is written to any new value (including %111),  $\overline{\text{IRQ}}7$  will be recognized as a new  $\overline{\text{IRQ}}7$ .

Interrupt requests are sampled on consecutive falling edges of the system clock. Interrupt request input circuitry has hysteresis. To be valid, a request signal must be asserted for at least two consecutive clock periods. Valid requests do not cause immediate exception processing, but are left pending. Pending requests are processed at instruction boundaries or when exception processing of higher-priority interrupts is complete.

The CPU32 does not latch the priority of a pending interrupt request. If an interrupt source of higher priority makes a service request while a lower priority request is pending, the higher priority request is serviced. If an interrupt request with a priority equal to or lower than the current IP mask value is made, the CPU32 does not recognize the occurrence of the request. If simultaneous interrupt requests of different priorities are made, and both have a priority greater than the mask value, the CPU32 recognizes the higher-level request.

### 5.8.3 Interrupt Acknowledge and Arbitration

When the CPU32 detects one or more interrupt requests of a priority higher than the interrupt priority mask value, it places the interrupt request level on the address bus and initiates a CPU space read cycle. The request level serves two purposes: it is decoded by modules or external devices that have requested interrupt service, to determine whether the current interrupt acknowledge cycle pertains to them, and it is latched into the interrupt priority mask field in the CPU32 status register to preclude further interrupts of lower priority during interrupt service.

Modules or external devices that have requested interrupt service must decode the IP mask value placed on the address bus during the interrupt acknowledge cycle and respond if the priority of the service request corresponds to the mask value. However, before modules or external devices respond, interrupt arbitration takes place.

Arbitration is performed by means of serial contention between values stored in individual module interrupt arbitration (IARB) fields. Each module that can make an interrupt service request, including the SIM, has an IARB field in its configuration register. IARB fields can be assigned values from %0000 to %1111. In order to implement an arbitration scheme, each module that can request interrupt service must be assigned a unique, non-zero IARB field value during system initialization. Arbitration priorities range from %0001 (lowest) to %1111 (highest) — if the CPU recognizes an interrupt service request from a source that has an IARB field value of %0000, a spurious interrupt exception is processed.

#### **WARNING**

Do not assign the same arbitration priority to more than one module. When two or more IARB fields have the same nonzero value, the CPU32 interprets multiple vector numbers at the same time, with unpredictable consequences.

Because the EBI manages external interrupt requests, the SIM IARB value is used for arbitration between internal and external interrupt requests. The reset value of IARB for the SIM is %1111, and the reset IARB value for all other modules is %0000.

Although arbitration is intended to deal with simultaneous requests of the same interrupt level, it always takes place, even when a single source is requesting service. This is important for two reasons: the EBI does not transfer the interrupt acknowledge read cycle to the external bus unless the SIM wins contention, and failure to contend causes the interrupt acknowledge bus cycle to be terminated early by a bus error.

When arbitration is complete, the module with both the highest asserted interrupt level and the highest arbitration priority must terminate the bus cycle. Internal modules place an interrupt vector number on the data bus and generate appropriate internal cycle termination signals. In the case of an external interrupt request, after the interrupt acknowledge cycle is transferred to the external bus, the appropriate external device must respond with a vector number, then generate data and size acknowledge ( $\overline{DSACK}$ ) termination signals, or it must assert the autovector ( $\overline{AVEC}$ ) request signal. If the device does not respond in time, the SIM bus monitor, if enabled, asserts the bus error signal ( $\overline{BERR}$ ), and a spurious interrupt exception is taken.

Chip-select logic can also be used to generate internal  $\overline{AVEC}$  or  $\overline{DSACK}$  signals in response to interrupt requests from external devices. Refer to **5.9.3 Using Chip-Select Signals for Interrupt Acknowledge** for more information. Chip-select address match logic functions only after the EBI transfers an interrupt acknowledge cycle to the external bus following IARB contention. If an internal module makes an interrupt request of a certain priority, and the appropriate chip-select registers are programmed to generate  $\overline{AVEC}$  or  $\overline{DSACK}$  signals in response to an interrupt acknowledge cycle for that priority level, chip-select logic does not respond to the interrupt acknowledge cycle, and the internal module supplies a vector number and generates internal cycle termination signals.

For periodic timer interrupts, the PIRQ[2:0] field in the periodic interrupt control register (PICR) determines PIT priority level. A PIRQ[2:0] value of %000 means that PIT interrupts are inactive. By hardware convention, when the CPU32 receives simultaneous interrupt requests of the same level from more than one SIM source (including external devices), the periodic interrupt timer is given the highest priority, followed by the  $\overline{IRQ}$  pins.

#### 5.8.4 Interrupt Processing Summary

A summary of the entire interrupt processing sequence follows. When the sequence begins, a valid interrupt service request has been detected and is pending.

- A. The CPU32 finishes higher priority exception processing or reaches an instruction boundary.
- B. The processor state is stacked. The S bit in the status register is set, establishing supervisor access level, and bits T1 and T0 are cleared, disabling tracing.
- C. The interrupt acknowledge cycle begins:
  1. FC[2:0] are driven to %111 (CPU space) encoding.
  2. The address bus is driven as follows: ADDR[23:20] = %1111; ADDR[19:16] = %1111, which indicates that the cycle is an interrupt acknowledge CPU space cycle; ADDR[15:4] = %111111111111; ADDR[3:1] = the priority of the interrupt request being acknowledged; and ADDR0 = %1.
  3. The request level is latched from the address bus into the IP mask field in the status register.
- D. Modules that have requested interrupt service decode the priority value on ADDR[3:1]. If request priority is the same as acknowledged priority, arbitration by IARB contention takes place.

- E. After arbitration, the interrupt acknowledge cycle is completed in one of the following ways:
  - 1. When there is no contention ( $IARB = \%0000$ ), the spurious interrupt monitor asserts  $\overline{BERR}$ , and the CPU32 generates the spurious interrupt vector number.
  - 2. The dominant interrupt source (external or internal) supplies a vector number and  $\overline{DSACK}$  signals appropriate to the access. The CPU32 acquires the vector number.
  - 3. The  $\overline{AVEC}$  signal is asserted (the signal can be asserted by the dominant external interrupt source or the pin can be tied low), and the CPU32 generates an autovector number corresponding to interrupt priority.
  - 4. The bus monitor asserts  $\overline{BERR}$  and the CPU32 generates the spurious interrupt vector number.
- F. The vector number is converted to a vector address.
- G. The content of the vector address is loaded into the PC and the processor transfers control to the exception handler routine.

### 5.8.5 Interrupt Acknowledge Bus Cycles

Interrupt acknowledge bus cycles are CPU32 space cycles that are generated during exception processing. For further information about the types of interrupt acknowledge bus cycles determined by  $\overline{AVEC}$  or  $\overline{DSACK}$ , refer to **APPENDIX A ELECTRICAL CHARACTERISTICS** and the *SIM Reference Manual* (SIMRM/AD).

### 5.9 Chip-Selects

Typical microcontrollers require additional hardware to provide external chip-select and address decode signals. The MCU includes 12 programmable chip-select circuits that can provide 2 to 16 clock-cycle access to external memory and peripherals. Address block sizes of two Kbytes to one Mbyte can be selected. **Figure 5-19** is a diagram of a basic system that uses chip-selects.

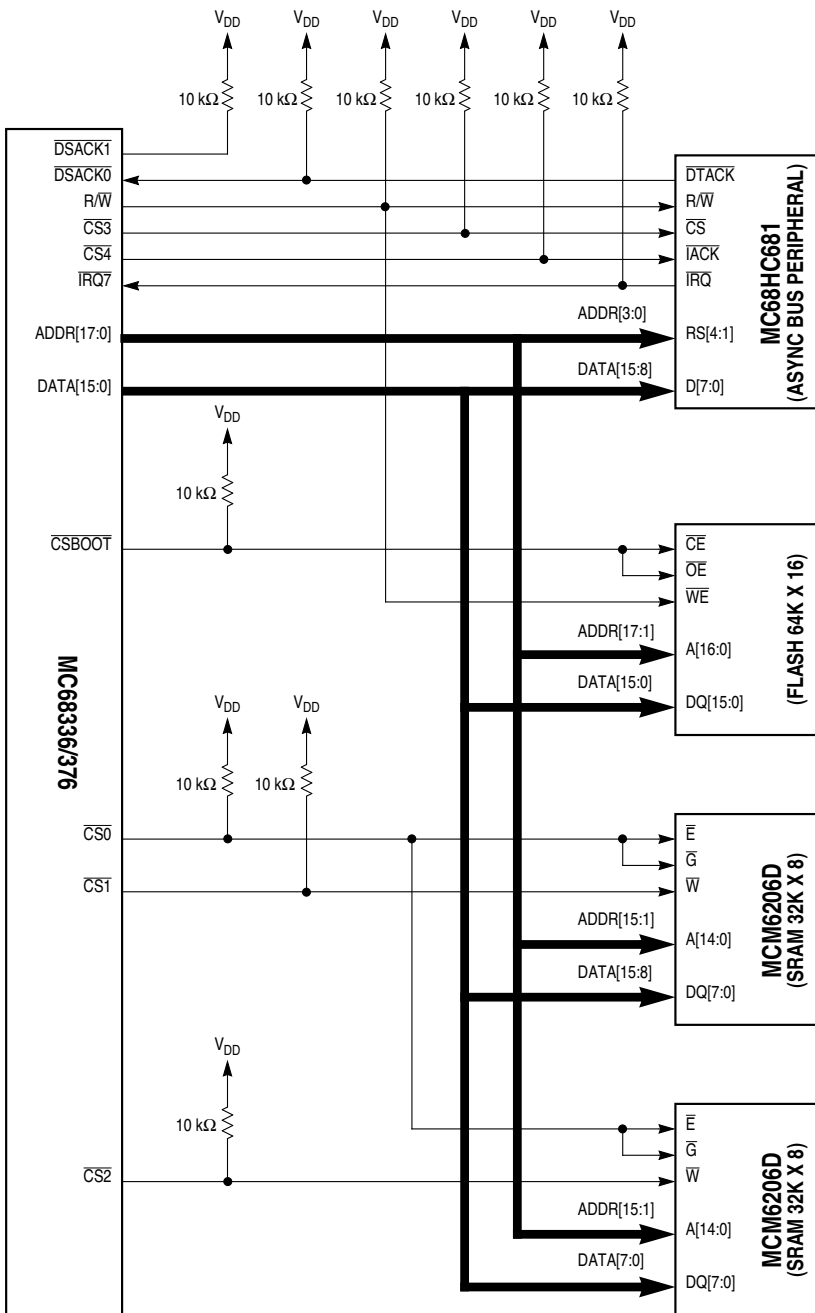

68300 SIMSCIM BUS

Figure 5-19 Basic MCU System

Chip-select assertion can be synchronized with bus control signals to provide output enable, read/write strobe, or interrupt acknowledge signals. Chip-select logic can also generate  $\overline{DSACK}$  and  $\overline{AVEC}$  signals internally. A single  $\overline{DSACK}$  generator is shared by all chip-selects. Each signal can also be synchronized with the ECLK signal available on ADDR23.

When a memory access occurs, chip-select logic compares address space type, address, type of access, transfer size, and interrupt priority (in the case of interrupt acknowledge) to parameters stored in chip-select registers. If all parameters match, the appropriate chip-select signal is asserted. Select signals are active low.

If a chip-select function is given the same address as a microcontroller module or an internal memory array, an access to that address goes to the module or array, and the chip-select signal is not asserted. The external address and data buses do not reflect the internal access.

All chip-select circuits are configured for operation out of reset. However, all chip-select signals except  $\overline{CSBOOT}$  are disabled, and cannot be asserted until the BYTE[1:0] field in the corresponding option register is programmed to a non-zero value to select a transfer size. The chip-select option register must not be written until a base address has been written to a proper base address register. Alternate functions for chip-select pins are enabled if appropriate data bus pins are held low at the release of  $\overline{RESET}$ . Refer to **5.7.3.1 Data Bus Mode Selection** for more information. **Figure 5-20** is a functional diagram of a single chip-select circuit.

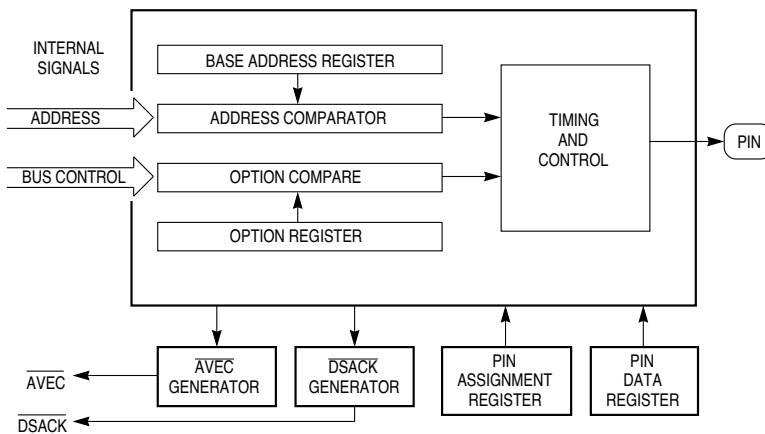

CHIP SEL BLOCK

**Figure 5-20 Chip-Select Circuit Block Diagram**

## 5.9.1 Chip-Select Registers

Each chip-select pin can have one or more functions. Chip-select pin assignment registers CSPAR[0:1] determine functions of the pins. Pin assignment registers also determine port size (8- or 16-bit) for dynamic bus allocation. A pin data register (PORTC) latches data for chip-select pins that are used for discrete output.

Blocks of addresses are assigned to each chip-select function. Block sizes of two Kbytes to one Mbyte can be selected by writing values to the appropriate base address register (CSBAR[0:10] and CSBARBT). Multiple chip-selects assigned to the same block of addresses must have the same number of wait states. The base address register for a chip-select line should be written to a value that is an exact integer multiple of both the block size and the size of the memory device being selected.

Chip-select option registers (CSORBT and CSOR[0:10]) determine timing of and conditions for assertion of chip-select signals. Eight parameters, including operating mode, access size, synchronization, and wait state insertion can be specified.

Initialization software usually resides in a peripheral memory device controlled by the chip-select circuits. A set of special chip-select functions and registers (CSORBT and CSBARBT) is provided to support bootstrap operation.

Comprehensive address maps and register diagrams are provided in **APPENDIX D REGISTER SUMMARY**.

### 5.9.1.1 Chip-Select Pin Assignment Registers

The pin assignment registers contain twelve 2-bit fields that determine the functions of the chip-select pins. Each pin has two or three possible functions, as shown in **Table 5-18**.

**Table 5-18 Chip-Select Pin Functions**

Chip-Select	Alternate Function	Discrete Output
$\overline{\text{CSBOOT}}$	$\overline{\text{CSBOOT}}$	—
$\overline{\text{CS0}}$	BR	—
$\overline{\text{CS1}}$	BG	—
$\overline{\text{CS2}}$	BGACK	—
$\overline{\text{CS3}}$	FC0	PC0
$\overline{\text{CS4}}$	FC1	PC1
$\overline{\text{CS5}}$	FC2	PC2
$\overline{\text{CS6}}$	ADDR19	PC3
$\overline{\text{CS7}}$	ADDR20	PC4
$\overline{\text{CS8}}$	ADDR21	PC5
$\overline{\text{CS9}}$	ADDR22	PC6
$\overline{\text{CS10}}$	ADDR23	ECLK

**Table 5-19** shows pin assignment field encoding. Pins that have no discrete output function must not use the %00 encoding as this will cause the alternate function to be selected. For instance, %00 for  $\overline{\text{CS0}}$ /BR will cause the pin to perform the BR function.

**Table 5-19 Pin Assignment Field Encoding**

CSxPA[1:0]	Description
00	Discrete output
01	Alternate function
10	Chip-select (8-bit port)
11	Chip-select (16-bit port)

Port size determines the way in which bus transfers to an external address are allocated. Port size of eight bits or sixteen bits can be selected when a pin is assigned as a chip-select. Port size and transfer size affect how the chip-select signal is asserted. Refer to **5.9.1.3 Chip-Select Option Registers** for more information.

Out of reset, chip-select pin function is determined by the logic level on a corresponding data bus pin. The data bus pins have weak internal pull-up drivers, but can be held low by external devices. Refer to **5.7.3.1 Data Bus Mode Selection** for more information. Either 16-bit chip-select function (%11) or alternate function (%01) can be selected during reset. All pins except the boot ROM select pin (CSBOOT) are disabled out of reset. There are twelve chip-select functions and only eight associated data bus pins. There is not a one-to-one correspondence. Refer to **5.9.4 Chip-Select Reset Operation** for more detailed information.

The  $\overline{\text{CSBOOT}}$  signal is enabled out of reset. The state of the DATA0 line during reset determines what port width CSBOOT uses. If DATA0 is held high (either by the weak internal pull-up driver or by an external pull-up device), 16-bit port size is selected. If DATA0 is held low, 8-bit port size is selected.

A pin programmed as a discrete output drives an external signal to the value specified in the port C register. No discrete output function is available on pins CSBOOT, BR, BG, or BGACK. ADDR23 provides the ECLK output rather than a discrete output signal.

When a pin is programmed for discrete output or alternate function, internal chip-select logic still functions and can be used to generate DSACK or AVEC internally on an address and control signal match.

### 5.9.1.2 Chip-Select Base Address Registers

Each chip-select has an associated base address register. A base address is the lowest address in the block of addresses enabled by a chip-select. Block size is the extent of the address block above the base address. Block size is determined by the value contained in BLKSZ[2:0]. Multiple chip-selects assigned to the same block of addresses must have the same number of wait states.

BLKSZ[2:0] determines which bits in the base address field are compared to corresponding bits on the address bus during an access. Provided other constraints determined by option register fields are also satisfied, when a match occurs, the associated chip-select signal is asserted. **Table 5-20** shows BLKSZ[2:0] encoding.



**Table 5-20 Block Size Encoding**

BLKSZ[2:0]	Block Size	Address Lines Compared
000	2 Kbytes	ADDR[23:11]
001	8 Kbytes	ADDR[23:13]
010	16 Kbytes	ADDR[23:14]
011	64 Kbytes	ADDR[23:16]
100	128 Kbytes	ADDR[23:17]
101	256 Kbytes	ADDR[23:18]
110	512 Kbytes	ADDR[23:19]
111	1 Mbyte	ADDR[23:20]

The chip-select address compare logic uses only the most significant bits to match an address within a block. The value of the base address must be an integer multiple of the block size.

After reset, the MCU fetches the initialization routine from the address contained in the reset vector, located beginning at address \$000000 of program space. To support bootstrap operation from reset, the base address field in the boot chip-select base address register (CSBARBT) has a reset value of \$000, which corresponds to a base address of \$000000 and a block size of one Mbyte. A memory device containing the reset vector and initialization routine can be automatically enabled by  $\overline{\text{CSBOOT}}$  after a reset. Refer to **5.9.4 Chip-Select Reset Operation** for more information.

### 5.9.1.3 Chip-Select Option Registers

Option register fields determine timing of and conditions for assertion of chip-select signals. To assert a chip-select signal, and to provide  $\overline{\text{DSACK}}$  or autovector support, other constraints set by fields in the option register and in the base address register must also be satisfied. The following paragraphs summarize option register functions. Refer to **D.2.21 Chip-Select Option Registers** for register and bit field information.

The MODE bit determines whether chip-select assertion simulates an asynchronous bus cycle, or is synchronized to the M6800-type bus clock signal ECLK available on ADDR23. Refer to **5.3 System Clock** for more information on ECLK.

BYTE[1:0] controls bus allocation for chip-select transfers. Port size, set when a chip-select is enabled by a pin assignment register, affects signal assertion. When an 8-bit port is assigned, any BYTE field value other than %00 enables the chip-select signal. When a 16-bit port is assigned, however, BYTE field value determines when the chip-select is enabled. The BYTE fields for  $\overline{\text{CS}}[10:0]$  are cleared during reset. However, both bits in the boot ROM chip-select option register (CSORBT) BYTE field are set (%11) when the  $\overline{\text{RESET}}$  signal is released.

$\overline{\text{RW}}[1:0]$  causes a chip-select signal to be asserted only for a read, only for a write, or for both read and write. Use this field in conjunction with the STRB bit to generate asynchronous control signals for external devices.

The STRB bit controls the timing of a chip-select assertion in asynchronous mode. Selecting address strobe causes a chip-select signal to be asserted synchronized with the address strobe. Selecting data strobe causes a chip-select signal to be asserted synchronized with the data strobe. This bit has no effect in synchronous mode.

$\overline{DSACK}[3:0]$  specifies the source of  $\overline{DSACK}$  in asynchronous mode. It also allows the user to optimize bus speed in a particular application by controlling the number of wait states that are inserted.

#### NOTE

The external  $\overline{DSACK}$  pins are always active.

SPACE[1:0] determines the address space in which a chip-select is asserted. An access must have the space type represented by the SPACE[1:0] encoding in order for a chip-select signal to be asserted.

IPL[2:0] contains an interrupt priority mask that is used when chip-select logic is set to trigger on external interrupt acknowledge cycles. When SPACE[1:0] is set to %00 (CPU space), interrupt priority (ADDR[3:1]) is compared to the IPL field. If the values are the same, and other option register constraints are satisfied, a chip-select signal is asserted. This field only affects the response of chip-selects and does not affect interrupt recognition by the CPU. Encoding %000 in the IPL field causes a chip-select signal to be asserted regardless of interrupt acknowledge cycle priority, provided all other constraints are met.

The  $\overline{AVEC}$  bit is used to make a chip-select respond to an interrupt acknowledge cycle. If the  $\overline{AVEC}$  bit is set, an autovector will be selected for the particular external interrupt being serviced. If  $\overline{AVEC}$  is zero, the interrupt acknowledge cycle will be terminated with  $\overline{DSACK}$ , and an external vector number must be supplied by an external device.

#### 5.9.1.4 Port C Data Register

The port C data register latches data for PORTC pins programmed as discrete outputs. When a pin is assigned as a discrete output, the value in this register appears at the output. PC[6:0] correspond to  $\overline{CS}[9:3]$ . Bit 7 is not used. Writing to this bit has no effect, and it always reads zero.

#### 5.9.2 Chip-Select Operation

When the MCU makes an access, enabled chip-select circuits compare the following items:

- Function codes to SPACE fields, and to the IPL field if the SPACE field encoding is not for CPU space.
- Appropriate address bus bits to base address fields.
- Read/write status to R/ $\overline{W}$  fields.
- ADDR0 and/or SIZ[1:0] bits to BYTE fields (16-bit ports only).
- Priority of the interrupt being acknowledged (ADDR[3:1]) to IPL fields (when the access is an interrupt acknowledge cycle).

When a match occurs, the chip-select signal is asserted. Assertion occurs at the same time as  $\overline{AS}$  or  $\overline{DS}$  assertion in asynchronous mode. Assertion is synchronized with ECLK in synchronous mode. In asynchronous mode, the value of the  $\overline{DSACK}$  field determines whether  $\overline{DSACK}$  is generated internally.  $\overline{DSACK}[3:0]$  also determines the number of wait states inserted before internal  $\overline{DSACK}$  assertion.

The speed of an external device determines whether internal wait states are needed. Normally, wait states are inserted into the bus cycle during S3 until a peripheral asserts  $\overline{DSACK}$ . If a peripheral does not generate  $\overline{DSACK}$ , internal  $\overline{DSACK}$  generation must be selected and a predetermined number of wait states can be programmed into the chip-select option register. Refer to the *SIM Reference Manual* (SIMRM/AD) for further information.

### 5.9.3 Using Chip-Select Signals for Interrupt Acknowledge

Ordinary bus cycles use supervisor or user space access, but interrupt acknowledge bus cycles use CPU space access. Refer to **5.6.4 CPU Space Cycles** and **5.8 Interrupts** for more information. There are no differences in flow for chip-selects in each type of space, but base and option registers must be properly programmed for each type of external bus cycle.

During a CPU space cycle, bits [15:3] of the appropriate base register must be configured to match ADDR[23:11], as the address is compared to an address generated by the CPU.

**Figure 5-21** shows CPU space encoding for an interrupt acknowledge cycle. FC[2:0] are set to %111, designating CPU space access. ADDR[3:1] indicate interrupt priority, and the space type field (ADDR[19:16]) is set to %1111, the interrupt acknowledge code. The rest of the address lines are set to one.

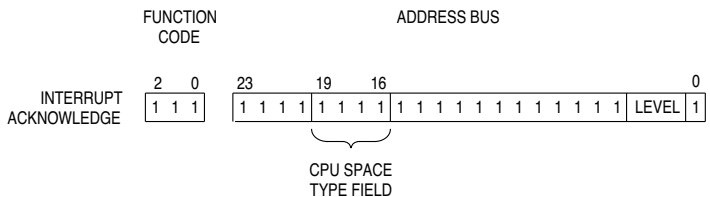

CPU SPACE IACK TIM

**Figure 5-21 CPU Space Encoding for Interrupt Acknowledge**

Because address match logic functions only after the EBI transfers an interrupt acknowledge cycle to the external address bus following IARB contention, chip-select logic generates  $\overline{AVEC}$  or  $\overline{DSACK}$  signals only in response to interrupt requests from external  $\overline{IRQ}$  pins. If an internal module makes an interrupt request of a certain priority, and the chip-select base address and option registers are programmed to generate  $\overline{AVEC}$  or  $\overline{DSACK}$  signals in response to an interrupt acknowledge cycle for that priority level, chip-select logic does not respond to the interrupt acknowledge cycle, and the internal module supplies a vector number and generates an internal  $\overline{DSACK}$  signal to terminate the cycle.

Perform the following operations before using a chip-select to generate an interrupt acknowledge signal:

1. Program the base address field to all ones.
2. Program block size to no more than 64 Kbytes, so that the address comparator checks ADDR[19:16] against the corresponding bits in the base address register. (The CPU32 places the CPU space bus cycle type on ADDR[19:16].)
3. Set the R/ $\overline{W}$  field to read only. An interrupt acknowledge cycle is performed as a read cycle.
4. Set the BYTE field to lower byte when using a 16-bit port, as the external vector for a 16-bit port is fetched from the lower byte. Set the BYTE field to upper byte when using an 8-bit port.

If an interrupting device does not provide a vector number, an autovector acknowledge must be generated, either by asserting the  $\overline{AVEC}$  pin or by generating  $\overline{AVEC}$  internally using the chip-select option register. This terminates the bus cycle.

#### 5.9.4 Chip-Select Reset Operation

The least significant bit of each of the 2-bit chip-select pin assignment fields in CSPAR0 and CSPAR1 each have a reset value of one. The reset values of the most significant bits of each field are determined by the states of DATA[7:1] during reset. There are weak internal pull-up drivers for each of the data lines so that chip-select operation is selected by default out of reset. However, the internal pull-up drivers can be overcome by bus loading effects.

To ensure a particular configuration out of reset, use an active device to put the data lines in a known state during reset. The base address fields in chip-select base address registers CSBAR[0:10] and chip-select option registers CSOR[0:10] have the reset values shown in **Table 5-21**. The BYTE fields of CSOR[0:10] have a reset value of “disable”, so that a chip-select signal cannot be asserted until the base and option registers are initialized.

**Table 5-21 Chip-Select Base and Option Register Reset Values**

Fields	Reset Values
Base address	\$000000
Block size	2 Kbyte
Async/sync mode	Asynchronous mode
Upper/lower byte	Disabled
Read/write	Disabled
AS/DS	AS
DSACK	No wait states
Address space	CPU space
IPL	Any level
Autovector	External interrupt vector

Following reset, the MCU fetches the initial stack pointer and program counter values from the exception vector table, beginning at \$000000 in supervisor program space. The CSBOOT chip-select signal is used to select an external boot device mapped to a base address of \$000000.

The MSB of the CSBTPA field in CSPAR0 has a reset value of one, so that chip-select function is selected by default out of reset. The BYTE field in chip-select option register CSORBT has a reset value of “both bytes” so that the select signal is enabled out of reset. The LSB of the CSBOOT field, determined by the logic level of DATA0 during reset, selects the boot ROM port size. When DATA0 is held low during reset, port size is eight bits. When DATA0 is held high during reset, port size is 16 bits. DATA0 has a weak internal pull-up driver, so that a 16-bit port is selected by default out of reset. However, the internal pull-up driver can be overcome by bus loading effects. To ensure a particular configuration out of reset, use an active device to put DATA0 in a known state during reset.

The base address field in the boot chip-select base address register CSBARBT has a reset value of all zeros, so that when the initial access to address \$000000 is made, an address match occurs, and the CSBOOT signal is asserted. The block size field in CSBARBT has a reset value of one Mbyte. **Table 5-22** shows CSBOOT reset values.

**Table 5-22 CSBOOT Base and Option Register Reset Values**

Fields	Reset Values
Base address	\$000000
Block size	1 Mbyte
Async/sync mode	Asynchronous mode
Upper/lower byte	Both bytes
Read/write	Read/write
AS/DS	AS
DSACK	13 wait states
Address space	Supervisor/user space
IPL <sup>1</sup>	Any level
Autovector	Interrupt vector externally

## NOTES:

1. These fields are not used unless “Address space” is set to CPU space.

## 5.10 Parallel Input/Output Ports

Sixteen SIM pins can be configured for general-purpose discrete input and output. Although these pins are organized into two ports, port E and port F, function assignment is by individual pin. Pin assignment registers, data direction registers, and data registers are used to implement discrete I/O.

### 5.10.1 Pin Assignment Registers

Bits in the port E and port F pin assignment registers (PEPAR and PFPAR) control the functions of the pins on each port. Any bit set to one defines the corresponding pin as a bus control signal. Any bit cleared to zero defines the corresponding pin as an I/O pin.

### 5.10.2 Data Direction Registers

Bits in the port E and port F data direction registers (DDRE and DDRF) control the direction of the pin drivers when the pins are configured as I/O. Any bit in a register set to one configures the corresponding pin as an output. Any bit in a register cleared to zero configures the corresponding pin as an input. These registers can be read or written at any time.

### 5.10.3 Data Registers

A write to the port E and port F data registers (PORTE[0:1] and PORTF[0:1]) is stored in an internal data latch, and if any pin in the corresponding port is configured as an output, the value stored for that bit is driven out on the pin. A read of a data register returns the value at the pin only if the pin is configured as a discrete input. Otherwise, the value read is the value stored in the port data register. Both data registers can be accessed in two locations and can be read or written at any time.

## 5.11 Factory Test

The test submodule supports scan-based testing of the various MCU modules. It is integrated into the SIM to support production test. Test submodule registers are intended for Motorola use only. Register names and addresses are provided in **D.2.2 System Integration Test Register** and **D.2.5 System Integration Test Register (ECLK)** to show the user that these addresses are occupied. The QUOT pin is also used for factory test.

## SECTION 6 STANDBY RAM MODULE

The standby RAM (SRAM) module consists of a control register block and a 4-Kbyte array of fast (two bus cycle) static RAM. The SRAM is especially useful for system stacks and variable storage. The SRAM can be mapped to any address that is a multiple of the array size so long as SRAM boundaries do not overlap the module control registers (overlap makes the registers inaccessible). Data can be read/written in bytes, words or long words. SRAM is powered by  $V_{DD}$  in normal operation. During power-down, SRAM contents can be maintained by power from the  $V_{STBY}$  input. Power switching between sources is automatic.

### 6.1 SRAM Register Block

There are four SRAM control registers: the RAM module configuration register (RAM-MCR), the RAM test register (RAMTST), and the RAM array base address registers (RAMBAH/RAMBAL). To protect these registers from accidental modification, they are always mapped to supervisor data space.

The module mapping bit (MM) in the SIM configuration register defines the most significant bit (ADDR23) of the IMB address for each MC68336/376 module. Refer to **5.2.1 Module Mapping** for information on how the state of MM affects the system.

The SRAM control register consists of eight bytes, but not all locations are implemented. Unimplemented register addresses are read as zeros, and writes have no effect. Refer to **D.3 Standby RAM Module** for register block address map and register bit/field definitions.

### 6.2 SRAM Array Address Mapping

Base address registers RAMBAH and RAMBAL are used to specify the SRAM array base address in the memory map. RAMBAH and RAMBAL can only be written while the SRAM is in low-power stop mode (RAMMCR STOP = 1) and the base address lock (RAMMCR RLCK = 0) is disabled. RLCK can be written once only to a value of one. This prevents accidental remapping of the array.

### 6.3 SRAM Array Address Space Type

RASP[1:0] in RAMMCR determine the SRAM array address space type. The SRAM module can respond to both program and data space accesses or to program space accesses only. This allows code to be executed from RAM, and permits use of program counter relative addressing mode for operand fetches from the array.

In addition, RASP[1:0] specify whether access to the SRAM module can be made in supervisor mode only, or in either user or supervisor mode. If supervisor-only access is specified, accesses in user mode are ignored by the SRAM control logic and can be decoded externally.

Table 6-1 shows RASP[1:0] field encodings.

**Table 6-1 SRAM Array Address Space Type**

RASP[1:0]	Space
00	Unrestricted program and data
01	Unrestricted program
10	Supervisor program and data
11	Supervisor program

Refer to **4.5 Addressing Modes** for more information on addressing modes. Refer to **5.5.1.7 Function Codes** for more information concerning address space types and program/data space access.

## 6.4 Normal Access

The array can be accessed by byte, word, or long word. A byte or aligned word access takes one bus cycle or two system clocks. A long word access requires two bus cycles. Misaligned accesses are not permitted by the CPU32 and will result in an address error exception. Refer to **5.6 Bus Operation** for more information concerning access times.

## 6.5 Standby and Low-Power Stop Operation

Standby and low-power modes should not be confused. Standby mode maintains the RAM array when the main MCU power supply is turned off. Low-power stop mode allows the central processor unit to control MCU power consumption.

Relative voltage levels of the MCU  $V_{DD}$  and  $V_{STBY}$  pins determine whether the SRAM is in standby mode. SRAM circuitry switches to the standby power source when  $V_{DD}$  drops below specified limits. If specified standby supply voltage levels are maintained during the transition, there is no loss of memory when switching occurs. The RAM array cannot be accessed while the SRAM module is powered from  $V_{STBY}$ . If standby operation is not desired, connect the  $V_{STBY}$  pin to  $V_{SS}$ .

$I_{SB}$  (SRAM standby current) values may vary while  $V_{DD}$  transitions occur. Refer to **APPENDIX A ELECTRICAL CHARACTERISTICS** for standby switching and power consumption specifications.

Setting the STOP bit in RAMMCR switches the SRAM module to low-power stop mode. In low-power stop mode, the array retains its contents, but cannot be read or written by the CPU32. STOP can be written only when the CPU32 is operating in supervisor mode.

The SRAM module will switch to standby mode while it is in low-power stop mode, provided the operating constraints discussed above are met.



## 6.6 Reset

Reset places the SRAM in low-power stop mode, enables program space access, and clears the base address registers and the register lock bit. These actions make it possible to write a new base address into the registers.

When a synchronous reset occurs while a byte or word SRAM access is in progress, the access is completed. If reset occurs during the first word access of a long-word operation, only the first word access is completed. If reset occurs during the second word access of a long-word operation, the entire access is completed. Data being read from or written to the RAM may be corrupted by asynchronous reset. Refer to **5.7 Reset** for more information about resets.



## SECTION 7 MASKED ROM MODULE

The masked ROM module (MRM) consists of a fixed-location control register block and an 8-Kbyte mask-programmed read-only memory array that can be mapped to any 8-Kbyte boundary in the system memory map. The MRM can be programmed to insert wait states to accommodate migration from slow external development memory. Access time depends upon the number of wait states specified, but can be as fast as two bus cycles. The MRM can be used for program accesses only, or for program and data accesses. Data can be read in bytes, words or long words. The MRM can be configured to support system bootstrap during reset.

### 7.1 MRM Register Block

There are three MRM control registers: the masked ROM module configuration register (MRMCR), and the ROM array base address registers (ROMBAH and ROMBAL). In addition, the MRM register block contains signature registers (SIGHI and SIGLO), and ROM bootstrap words (ROMBS[0:3]).

The module mapping bit (MM) in the SIM configuration register defines the most significant bit (ADDR23) of the IMB address for each MC68336/376 module. **5.2.1 Module Mapping** contains information about how the state of MM affects the system.

The MRM control register block consists of 32 bytes, but not all locations are implemented. Unimplemented register addresses are read as zeros, and writes have no effect. Refer to **D.4 Masked ROM Module** for register block address map and register bit/field definitions.

### 7.2 MRM Array Address Mapping

Base address registers ROMBAH and ROMBAL are used to specify the ROM array base address in the memory map. Although the base address contained in ROMBAH and ROMBAL is mask-programmed, these registers can be written after reset to change the default array address if the base address lock bit (LOCK in MRMCR) is not masked to a value of one.

The MRM array can be mapped to any 8-Kbyte boundary in the memory map, but must not overlap other module control registers (overlap makes the registers inaccessible). If the array overlaps the MRM register block, addresses in the block are accessed instead of the corresponding array addresses.

ROMBAH and ROMBAL can only be written while the ROM is in low-power stop mode (MRMCR STOP = 1) and the base address lock (MRMCR LOCK = 0) is disabled. LOCK can be written once only to a value of one. This prevents accidental remapping of the array.

### 7.3 MRM Array Address Space Type

ASPC[1:0] in MRMCR determines ROM array address space type. The module can respond to both program and data space accesses or to program space accesses only. This allows code to be executed from ROM, and permits use of program counter relative addressing mode for operand fetches from the array. The default value of ASPC[1:0] is established during mask programming, but field value can be changed after reset if the LOCK bit in the MRMCR has not been masked to a value of one.

**Table 7-1** shows ASPC[1:0] field encodings.

**Table 7-1 ROM Array Space Type**

ASPC[1:0]	State Specified
00	Unrestricted program and data
01	Unrestricted program
10	Supervisor program and data
11	Supervisor program

Refer to **4.5 Addressing Modes** for more information on addressing modes. Refer to **5.5.1.7 Function Codes** for more information concerning address space types and program/data space access.

### 7.4 Normal Access

The array can be accessed by byte, word, or long word. A byte or aligned word access takes a minimum of one bus cycle (two system clocks). A long word access requires two bus cycles. Misaligned accesses are not permitted by the CPU32 and will result in an address error exception.

Access time can be optimized for a particular application by inserting wait states into each access. The number of wait states inserted is determined by the value of WAIT[1:0] in the MRMCR. Two, three, four, or five bus-cycle accesses can be specified. The default value WAIT[1:0] is established during mask programming, but field value can be changed after reset if the LOCK bit in the MRMCR has not been masked to a value of one.

**Table 7-2** shows WAIT[1:0] field encodings.

**Table 7-2 Wait States Field**

WAIT[1:0]	Cycles per Transfer
00	3
01	4
10	5
11	2

Refer to **5.6 Bus Operation** for more information concerning access times.

## 7.5 Low-Power Stop Mode Operation

Low-power stop mode minimizes MCU power consumption. Setting the STOP bit in MRMCR places the MRM in low-power stop mode. In low-power stop mode, the array cannot be accessed. The reset state of STOP is the complement of the logic state of DATA14 during reset. Low-power stop mode is exited by clearing STOP.

## 7.6 ROM Signature

Signature registers RSIGHI and RSIGLO contain a user-specified mask-programmed signature pattern. A special signature algorithm allows the user to verify ROM array content.

## 7.7 Reset

The state of the MRM following reset is determined by the default values programmed into the MRMCR  $\overline{\text{BOOT}}$ , LOCK, ASPC[1:0], and WAIT[1:0] bits. The default array base address is determined by the values programmed into ROMBAL and ROMBAH.

When the mask programmed value of the MRMCR  $\overline{\text{BOOT}}$  bit is zero, the contents of MRM bootstrap words ROMBS[0:3] are used as reset vectors. When the mask programmed value of the MRMCR  $\overline{\text{BOOT}}$  bit is one, reset vectors are fetched from external memory, and system integration module chip-select logic is used to assert the boot ROM select signal  $\overline{\text{CSBOOT}}$ . Refer to **5.9.4 Chip-Select Reset Operation** for more information concerning external boot ROM selection.



## SECTION 9 QUEUED SERIAL MODULE

This section is an overview of the queued serial module (QSM). Refer to the *QSM Reference Manual* (QSMRM/AD) for complete information about the QSM.

### 9.1 General

The QSM contains two serial interfaces, the queued serial peripheral interface (QSPI) and the serial communication interface (SCI). **Figure 9-1** is a block diagram of the QSM.

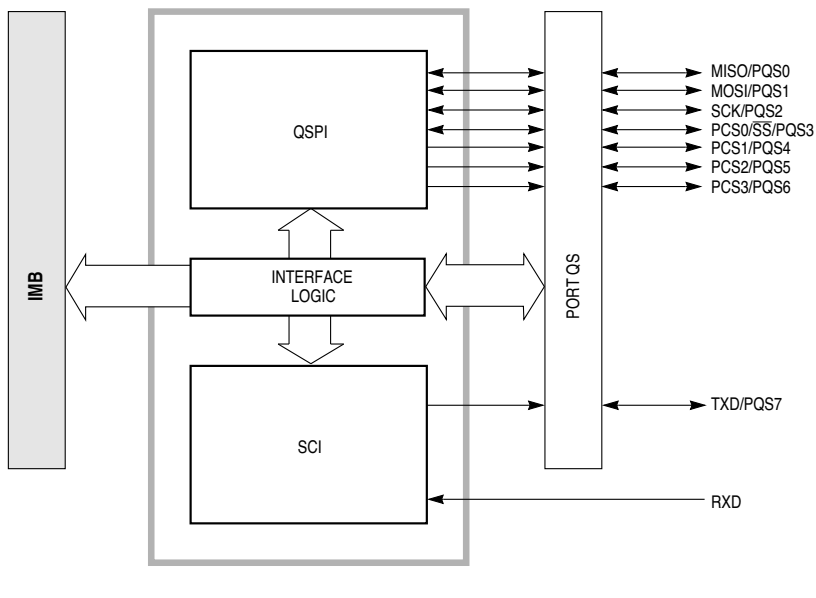

**Figure 9-1 QSM Block Diagram**

The QSPI provides peripheral expansion or interprocessor communication through a full-duplex, synchronous, three-line bus. Four programmable peripheral chip-selects can select up to sixteen peripheral devices by using an external one of sixteen line selector. A self-contained RAM queue allows up to sixteen serial transfers of eight to sixteen bits each or continuous transmission of up to a 256-bit data stream without CPU32 intervention. A special wrap-around mode supports continuous transmission/reception modes.

The SCI provides a standard non-return to zero (NRZ) mark/space format. It operates in either full- or half-duplex mode. There are separate transmitter and receiver enable bits and dual data buffers. A modulus-type baud rate generator provides rates from 110 baud to 655 kbaud with a 20.97 MHz system clock. Word length of either eight or nine bits is software selectable. Optional parity generation and detection provide either even or odd parity check capability. Advanced error detection circuitry catches glitches of up to 1/16 of a bit time in duration. Wake-up functions allow the CPU32 to run uninterrupted until meaningful data is available.

## 9.2 QSM Registers and Address Map

There are four types of QSM registers: QSM global registers, QSM pin control registers, QSPI registers, and SCI registers. Refer to **9.2.1 QSM Global Registers** and **9.2.2 QSM Pin Control Registers** for a discussion of global and pin control registers. Refer to **9.3.1 QSPI Registers** and **9.4.1 SCI Registers** for further information about QSPI and SCI registers. Writes to unimplemented register bits have no effect, and reads of unimplemented bits always return zero.

The QSM address map includes the QSM registers and the QSPI RAM. The MM bit in the system integration module configuration register (SIMCR) defines the most significant bit (ADDR23) of the IMB address for each module.

Refer to **D.6 Queued Serial Module** for a QSM address map and register bit and field definitions. **5.2.1 Module Mapping** contains more information about how the state of MM affects the system.

### 9.2.1 QSM Global Registers

The QSM configuration register (QSMCR) contains parameters for interfacing to the CPU32 and the intermodule bus. The QSM test register (QTEST) is used during factory test of the QSM. The QSM interrupt level register (QILR) determines the priority of interrupts requested by the QSM and the vector used when an interrupt is acknowledged. The QSM interrupt vector register (QIVR) contains the interrupt vector for both QSM submodules. QILR and QIVR are 8-bit registers located at the same word address.

#### 9.2.1.1 Low-Power Stop Operation

When the STOP bit in QSMCR is set, the system clock input to the QSM is disabled and the module enters a low-power operating state. QSMCR is the only register guaranteed to be readable while STOP is asserted. The QSPI RAM is not readable during LPSTOP. However, writes to RAM or any register are guaranteed valid while STOP is asserted. STOP can be set by the CPU32 and by reset.

System software must bring the QSPI and SCI to an orderly stop before asserting STOP to avoid data corruption. The IRQ mask level in the CPU32 status register should be set to a higher value than the IRQ level generated by the QSM module. The SCI receiver and transmitter should be disabled after transfers in progress are complete. The QSPI can be halted by setting the HALT bit in SPCR3 and then setting STOP after the HALTA flag is set. The IRQ mask in the CPU status register should be restored to its former level. Refer to **5.3.4 Low-Power Operation** for more information about low-power stop mode.



### 9.2.1.2 Freeze Operation

The FRZ[1:0] bits in QSMCR are used to determine what action is taken by the QSM when the IMB FREEZE signal is asserted. FREEZE is asserted when the CPU32 enters background debug mode. At the present time, FRZ0 has no effect; setting FRZ1 causes the QSPI to halt on the first transfer boundary following FREEZE assertion. Refer to **4.10.2 Background Debug Mode** for more information about background debugging mode.

### 9.2.1.3 QSM Interrupts

Both the QSPI and SCI can generate interrupt requests. Each has a separate interrupt request priority register. A single vector register is used to generate exception vector numbers.

The values of the ILQSPI and ILSCI fields in QILR determine the priority of QSPI and SCI interrupt requests. The values in these fields correspond to internal interrupt request signals  $\overline{\text{IRQ}}[7:1]$ . A value of %111 causes  $\overline{\text{IRQ}}7$  to be asserted when a QSM interrupt request is made. Lower field values cause correspondingly lower-numbered interrupt request signals to be asserted. Setting the ILQSPI or ILSCI field values to %000 disables interrupts for the respective section. If ILQSPI and ILSCI have the same non-zero value, and the QSPI and SCI make simultaneous interrupt requests, the QSPI has priority.

When the CPU32 acknowledges an interrupt request, it places the value in the status register interrupt priority (IP) mask on the address bus. The QSM compares the IP mask value to the priority of the request to determine whether it should contend for arbitration priority. Arbitration priority is determined by the value of the IARB field in QSMCR. Each module that generates interrupts must have a non-zero IARB value. Arbitration is performed by means of serial contention between values stored in individual module IARB fields.

When the QSM wins interrupt arbitration, it responds to the CPU32 interrupt acknowledge cycle by placing an interrupt vector number on the data bus. The vector number is used to calculate displacement into the CPU32 exception vector table. SCI and QSPI vector numbers are generated from the value in the QIVR INTV field. The values of bits INTV[7:1] are the same for QSPI and SCI. The value of INTV0 is supplied by the QSM when an interrupt request is made. INTV0 = 0 for SCI interrupt requests; INTV0 = 1 for QSPI interrupt requests.

At reset, INTV[7:0] is initialized to \$0F, the uninitialized interrupt vector number. To enable interrupt-driven serial communication, a user-defined vector number must be written to QIVR, and interrupt handler routines must be located at the addresses pointed to by the corresponding vector. Writes to INTV0 have no effect. Reads of INTV0 return a value of one.

Refer to **SECTION 4 CENTRAL PROCESSOR UNIT** and **SECTION 5 SYSTEM INTEGRATION MODULE** for more information about exceptions and interrupts.

## 9.2.2 QSM Pin Control Registers

The QSM uses nine pins. Eight of the pins can be used for serial communication or for parallel I/O. Clearing a bit in the port QS pin assignment register (PQSPAR) assigns the corresponding pin to general-purpose I/O; setting a bit assigns the pin to the QSPI. PQSPAR does not select I/O. In master mode, PQSPAR causes a bit to be assigned to the QSPI when SPE is set. In slave mode, the MISO pin, if assigned to the QSPI, remains under the control of the QSPI, regardless of the SPE bit. PQSPAR does not affect operation of the SCI.

The port QS data direction register (DDRQS) determines whether pins are inputs or outputs. Clearing a bit makes the corresponding pin an input; setting a bit makes the pin an output. DDRQS affects both QSPI function and I/O function. DDQS7 determines the direction of the TXD pin only when the SCI transmitter is disabled. When the SCI transmitter is enabled, the TXD pin is an output. PQSPAR and DDRQS are 8-bit registers located at the same word address. **Table 9-1** is a summary of QSM pin functions.

The port QS data register (PORTQS) latches I/O data. PORTQS writes drive pins defined as outputs. PORTQS reads return data present on the pins. To avoid driving undefined data, first write PORTQS, then configure DDRQS.

**Table 9-1 Effect of DDRQS on QSM Pin Function**

QSM Pin	Mode	DDRQS Bit	Bit State	Pin Function
MISO	Master	DDQS0	0	Serial data input to QSPI
			1	Disables data input
	Slave		0	Disables data output
			1	Serial data output from QSPI
MOSI	Master	DDQS1	0	Disables data output
			1	Serial data output from QSPI
	Slave		0	Serial data input to QSPI
			1	Disables data input
SCK <sup>1</sup>	Master	DDQS2	—	Clock output from QSPI
	Slave		—	Clock input to QSPI
PCS0/SS	Master	DDQS3	0	Assertion causes mode fault
			1	Chip-select output
	Slave		0	QSPI slave select input
			1	Disables slave select input
PCS[1:3]	Master	DDQS[4:6]	0	Disables chip-select output
			1	Chip-select output
	Slave		0	Inactive
			1	Inactive
TXD <sup>2</sup>	—	DDQS7	X	Serial data output from SCI
RXD	—	None	NA	Serial data input to SCI

**NOTES:**

1. PQS2 is a digital I/O pin unless the SPI is enabled (SPE set in SPCR1), in which case it becomes the QSPI serial clock SCK.
2. PQS7 is a digital I/O pin unless the SCI transmitter is enabled (TE set in SCCR1), in which case it becomes the SCI serial data output TXD.

### 9.3 Queued Serial Peripheral Interface

The queued serial peripheral interface (QSPI) is used to communicate with external devices through a synchronous serial bus. The QSPI is fully compatible with SPI systems found on other Motorola products, but has enhanced capabilities. The QSPI can perform full duplex three-wire or half duplex two-wire transfers. A variety of transfer rates, clocking, and interrupt-driven communication options is available. **Figure 9-2** displays a block diagram of the QSPI.

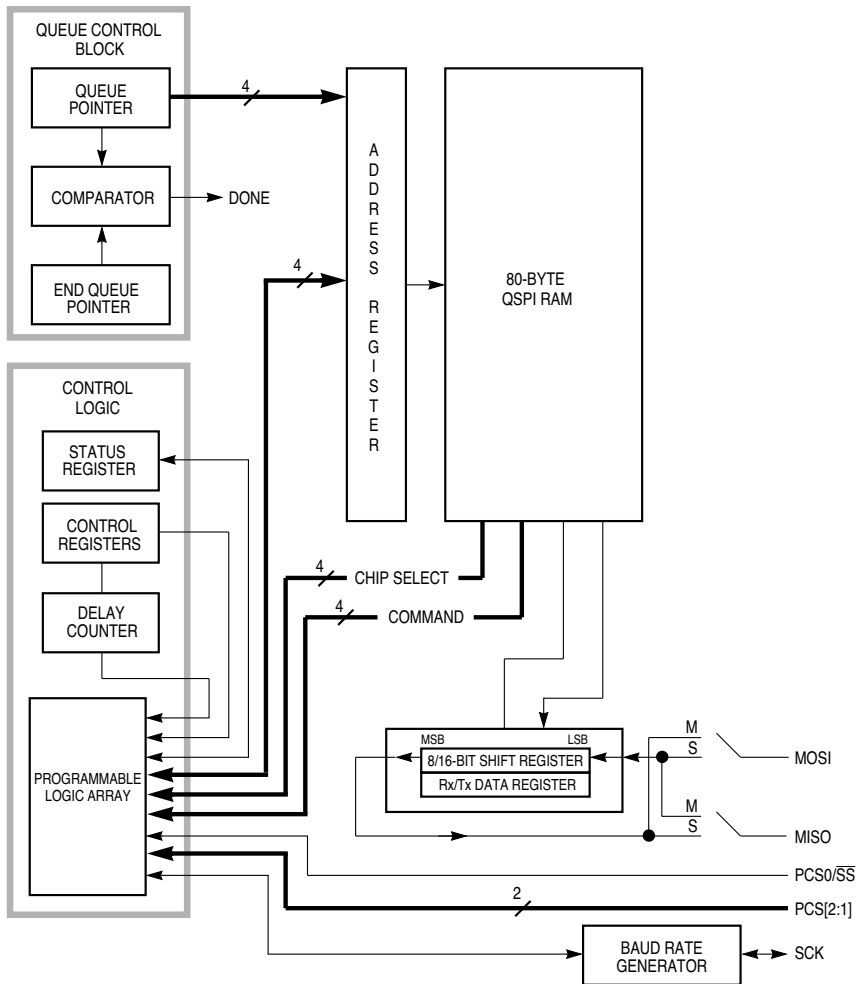

QSPI BLOCK

Figure 9-2 QSPI Block Diagram

Serial transfers of eight to sixteen can be specified. Programmable transfer length simplifies interfacing to devices that require different data lengths.

An inter-transfer delay of 17 to 8192 system clocks can be specified (default is 17 system clocks). Programmable delay simplifies the interface to devices that require different delays between transfers.

A dedicated 80-byte RAM is used to store received data, data to be transmitted, and a queue of commands. The CPU32 can access these locations directly. This allows serial peripherals to be treated like memory-mapped parallel devices.

The command queue allows the QSPI to perform up to 16 serial transfers without CPU32 intervention. Each queue entry contains all the information needed by the QSPI to independently complete one serial transfer.

A pointer identifies the queue location containing the data and command for the next serial transfer. Normally, the pointer address is incremented after each serial transfer, but the CPU32 can change the pointer value at any time. Support of multiple-tasks can be provided by segmenting the queue.

The QSPI has four peripheral chip-select pins. The chip-select signals simplify interfacing by reducing CPU32 intervention. If the chip-select signals are externally decoded, 16 independent select signals can be generated.

Wrap-around mode allows continuous execution of queued commands. In wrap-around mode, newly received data replaces previously received data in the receive RAM. Wrap-around mode can simplify the interface with A/D converters by continuously updating conversion values stored in the RAM.

Continuous transfer mode allows transfer of an uninterrupted bit stream. Any number of bits in a range from 8 to 256 can be transferred without CPU32 intervention. Longer transfers are possible, but minimal intervention is required to prevent loss of data. A standard delay of 17 system clocks is inserted between the transfer of each queue entry.

### 9.3.1 QSPI Registers

The programmer's model for the QSPI consists of the QSM global and pin control registers, four QSPI control registers (SPCR[0:3]), the status register (SPSR), and the 80-byte QSPI RAM. Registers and RAM can be read and written by the CPU32. Refer to **D.6 Queued Serial Module** for register bit and field definitions.

#### 9.3.1.1 Control Registers

Control registers contain parameters for configuring the QSPI and enabling various modes of operation. The CPU32 has read and write access to all control registers. The QSM has read access only to all bits except the SPE bit in SPCR1. Control registers must be initialized before the QSPI is enabled to insure defined operation. SPCR1 must be written last because it contains the QSPI enable bit (SPE).

Writing a new value to any control register except SPCR2 while the QSPI is enabled disrupts operation. SPCR2 is buffered. New SPCR2 values become effective after completion of the current serial transfer. Rewriting NEWQP in SPCR2 causes execu-

tion to restart at the designated location. Reads of SPCR2 return the current value of the register, not of the buffer. Writing the same value into any control register except SPCR2 while the QSPI is enabled has no effect on QSPI operation.

### 9.3.1.2 Status Register

SPSR contains information concerning the current serial transmission. Only the QSPI can set the bits in this register. The CPU32 reads SPSR to obtain QSPI status information and writes SPSR to clear status flags.

### 9.3.2 QSPI RAM

The QSPI contains an 80-byte block of dual-port access static RAM that can be accessed by both the QSPI and the CPU32. The RAM is divided into three segments: receive data RAM, transmit data RAM, and command data RAM. Receive data is information received from a serial device external to the MCU. Transmit data is information stored for transmission to an external device. Command control data defines transfer parameters. Refer to **Figure 9-3**, which shows RAM organization.

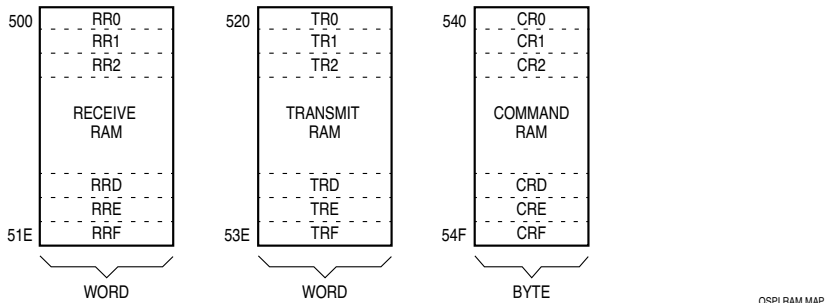

**Figure 9-3 QSPI RAM**

#### 9.3.2.1 Receive RAM

Data received by the QSPI is stored in this segment. The CPU32 reads this segment to retrieve data from the QSPI. Data stored in the receive RAM is right-justified. Unused bits in a receive queue entry are set to zero by the QSPI upon completion of the individual queue entry. The CPU32 can access the data using byte, word, or long-word addressing.

The CPTQP value in SPSR shows which queue entries have been executed. The CPU32 uses this information to determine which locations in receive RAM contain valid data before reading them.

#### 9.3.2.2 Transmit RAM

Data that is to be transmitted by the QSPI is stored in this segment and must be written to transmit RAM in a right-justified format. The QSPI cannot modify information in the transmit RAM. The QSPI copies the information to its data serializer for transmission. Information remains in transmit RAM until overwritten.

### 9.3.2.3 Command RAM

Command RAM is used by the QSPI in master mode. The CPU32 writes one byte of control information to this segment for each QSPI command to be executed. The QSPI cannot modify information in command RAM.

Command RAM consists of 16 bytes. Each byte is divided into two fields. The peripheral chip-select field enables peripherals for transfer. The command control field provides transfer options.

A maximum of 16 commands can be in the queue. Queue execution by the QSPI proceeds from the address in NEWQP through the address in ENDQP (both of these fields are in SPCR2).

### 9.3.3 QSPI Pins

The QSPI uses seven pins. These pins can be configured for general-purpose I/O when not needed for QSPI application.

Table 9-2 shows QSPI input and output pins and their functions.

**Table 9-2 QSPI Pins**

Pin Names	Mnemonics	Mode	Function
Master In Slave Out	MISO	Master Slave	Serial data input to QSPI Serial data output from QSPI
Master Out Slave In	MOSI	Master Slave	Serial data output from QSPI Serial data input to QSPI
Serial Clock	SCK	Master Slave	Clock output from QSPI Clock input to QSPI
Peripheral Chip Selects	PCS[3:1]	Master	Select peripherals
Slave Select	PCS0/ $\overline{SS}$	Master Master Slave	Selects peripherals Causes mode fault Initiates serial transfer

### 9.3.4 QSPI Operation

The QSPI uses a dedicated 80-byte block of static RAM accessible by both the QSPI and the CPU32 to perform queued operations. The RAM is divided into three segments. There are 16 command bytes, 16 transmit data words, and 16 receive data words. QSPI RAM is organized so that one byte of command data, one word of transmit data, and one word of receive data correspond to one queue entry, \$0-\$F.

The CPU32 initiates QSPI operation by setting up a queue of QSPI commands in command RAM, writing transmit data into transmit RAM, then enabling the QSPI. The QSPI executes the queued commands, sets a completion flag (SPIF), and then either interrupts the CPU32 or waits for intervention.

There are four queue pointers. The CPU32 can access three of them through fields in QSPI registers. The new queue pointer (NEWQP), contained in SPCR2, points to the first command in the queue. An internal queue pointer points to the command currently being executed. The completed queue pointer (CPTQP), contained in SPSR, points to the last command executed. The end queue pointer (ENDQP), contained in SPCR2, points to the final command in the queue.

The internal pointer is initialized to the same value as NEWQP. During normal operation, the command pointed to by the internal pointer is executed, the value in the internal pointer is copied into CPTQP, the internal pointer is incremented, and then the sequence repeats. Execution continues at the internal pointer address unless the NEWQP value is changed. After each command is executed, ENDQP and CPTQP are compared. When a match occurs, the SPIF flag is set and the QSPI stops and clears SPE, unless wrap-around mode is enabled.

At reset, NEWQP is initialized to \$0. When the QSPI is enabled, execution begins at queue address \$0 unless another value has been written into NEWQP. ENDQP is initialized to \$0 at reset, but should be changed to show the last queue entry before the QSPI is enabled. NEWQP and ENDQP can be written at any time. When NEWQP changes, the internal pointer value also changes. However, if NEWQP is written while a transfer is in progress, the transfer is completed normally. Leaving NEWQP and ENDQP set to \$0 transfers only the data in transmit RAM location \$0.

### 9.3.5 QSPI Operating Modes

The QSPI operates in either master or slave mode. Master mode is used when the MCU initiates data transfers. Slave mode is used when an external device initiates transfers. Switching between these modes is controlled by MSTR in SPCR0. Before entering either mode, appropriate QSM and QSPI registers must be initialized properly.

In master mode, the QSPI executes a queue of commands defined by control bits in each command RAM queue entry. Chip-select pins are activated, data is transmitted from the transmit RAM and received by the receive RAM.

In slave mode, operation proceeds in response to  $\overline{SS}$  pin activation by an external SPI bus master. Operation is similar to master mode, but no peripheral chip selects are generated, and the number of bits transferred is controlled in a different manner. When the QSPI is selected, it automatically executes the next queue transfer to exchange data with the external device correctly.

Although the QSPI inherently supports multi-master operation, no special arbitration mechanism is provided. A mode fault flag (MODF) indicates a request for SPI master arbitration. System software must provide arbitration. Note that unlike previous SPI systems, MSTR is not cleared by a mode fault being set nor are the QSPI pin output drivers disabled. The QSPI and associated output drivers must be disabled by clearing SPE in SPCR1.

**Figure 9-4** shows QSPI initialization. **Figures 9-5** through **9-9** show QSPI master and slave operation. The CPU32 must initialize the QSM global and pin registers and the QSPI control registers before enabling the QSPI for either mode of operation (refer to **9.5 QSM Initialization**). The command queue must be written before the QSPI is enabled for master mode operation. Any data to be transmitted should be written into transmit RAM before the QSPI is enabled. During wrap-around operation, data for subsequent transmissions can be written at any time.

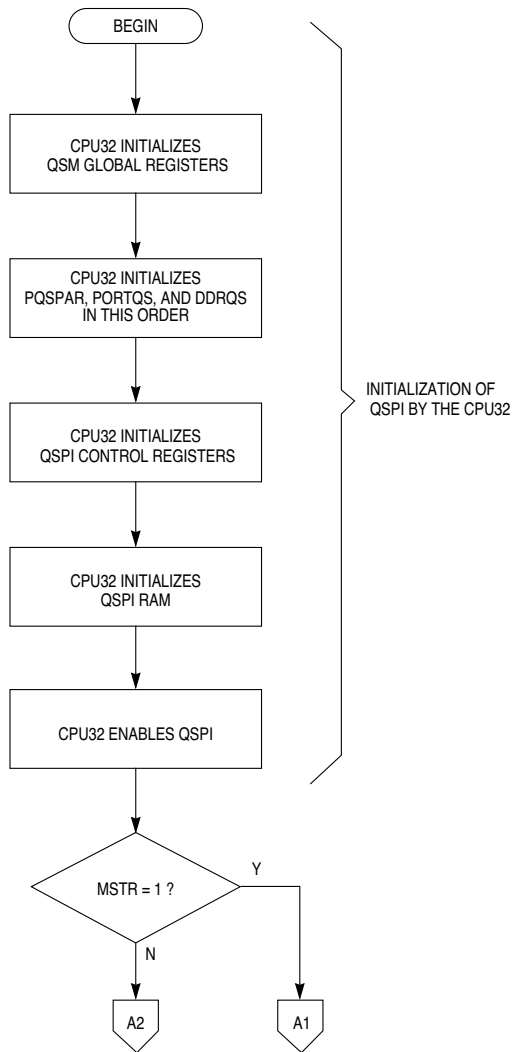

**Figure 9-4 Flowchart of QSPI Initialization Operation**



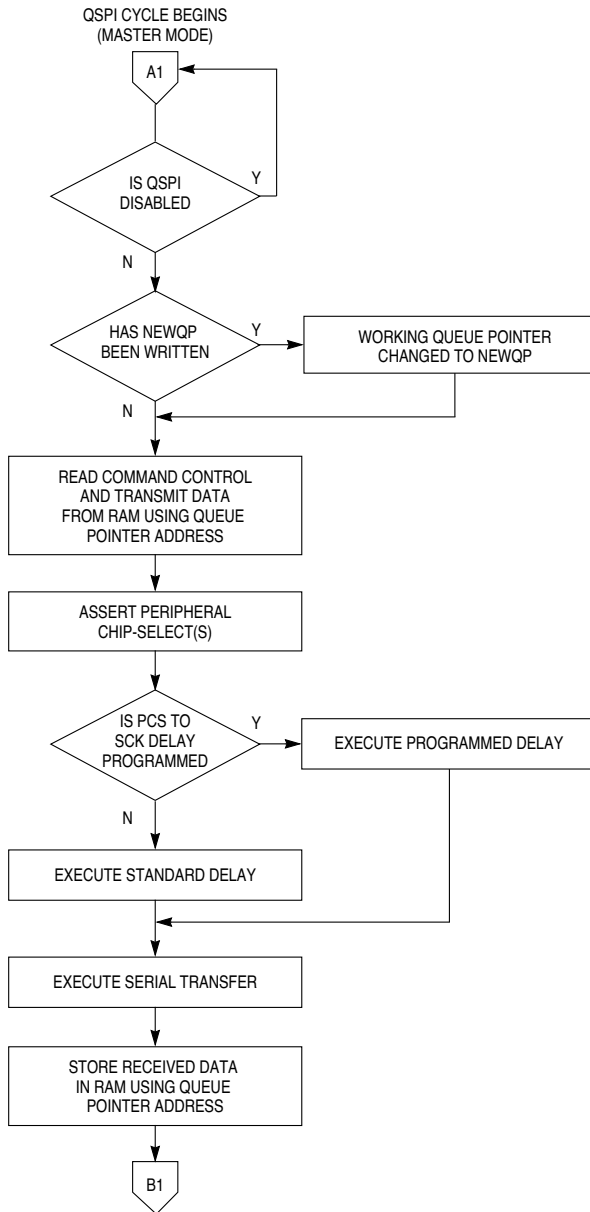

QSPI FLOW 2

**Figure 9-5 Flowchart of QSPI Master Operation (Part 1)**

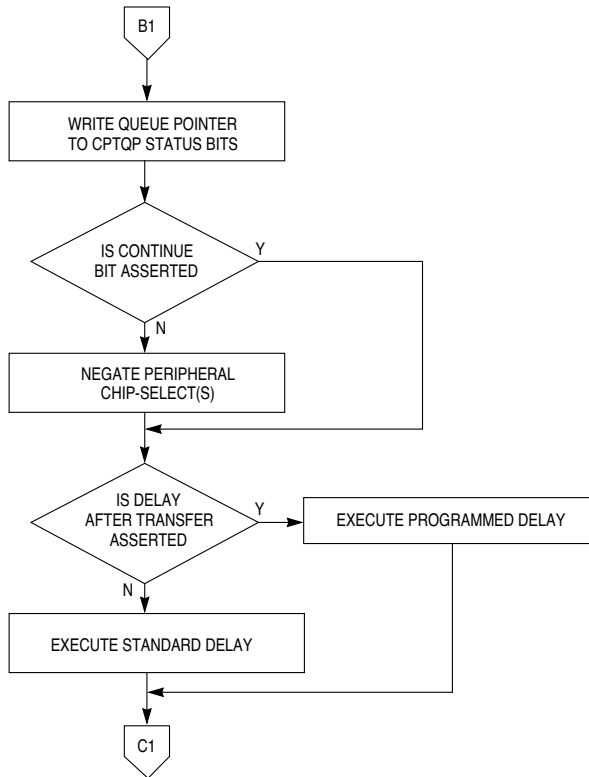

QSPI MSTR2 FLOW 3

**Figure 9-6 Flowchart of QSPI Master Operation (Part 2)**

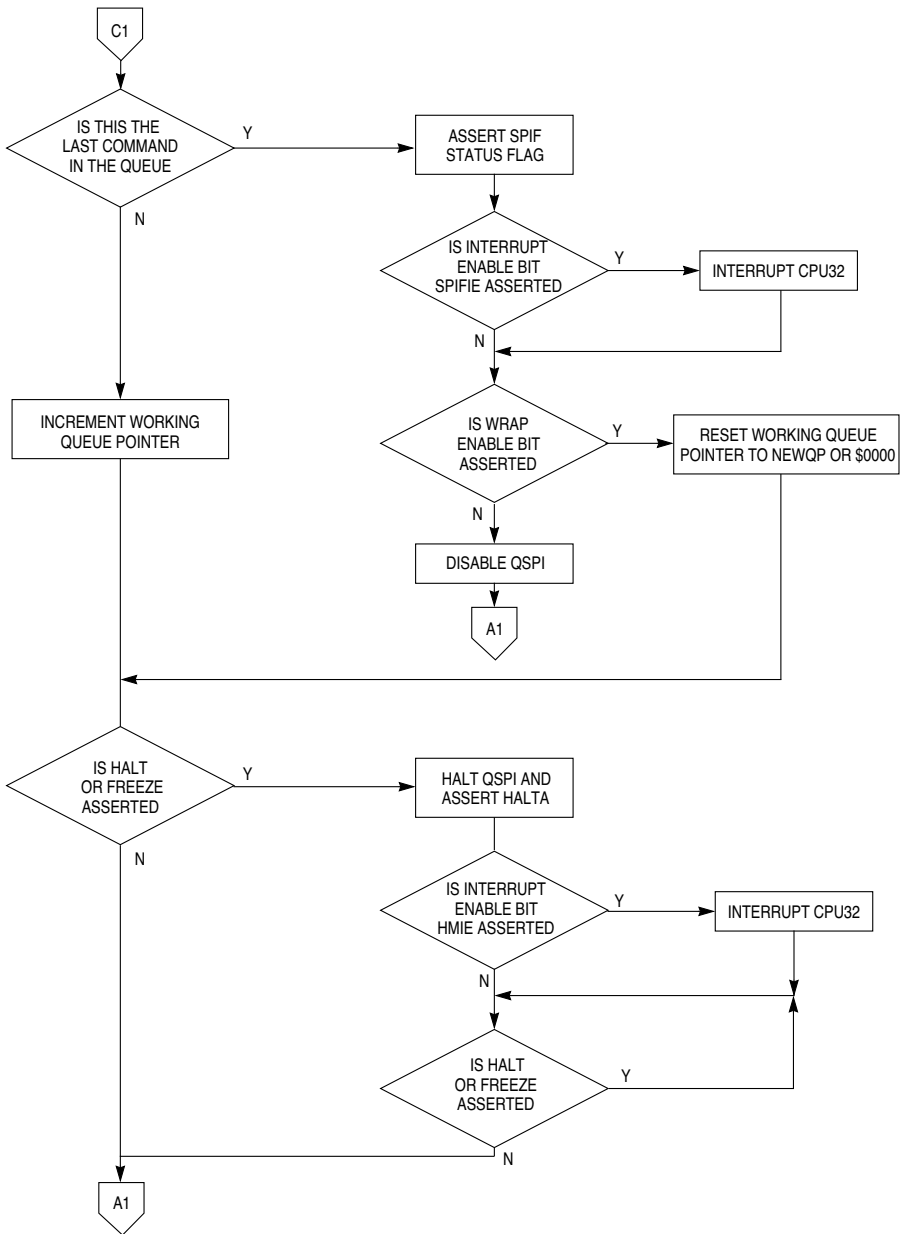

QSPI MSTR3 FLOW4

**Figure 9-7 Flowchart of QSPI Master Operation (Part 3)**

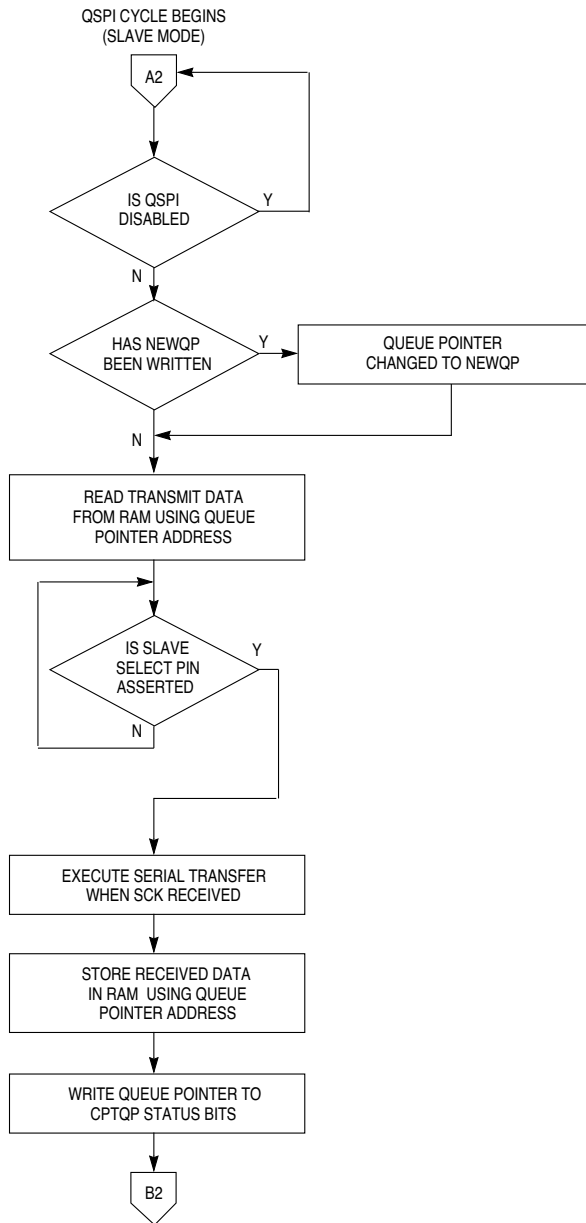

QSPI SLV1 FLOW 5

**Figure 9-8 Flowchart of QSPI Slave Operation (Part 1)**

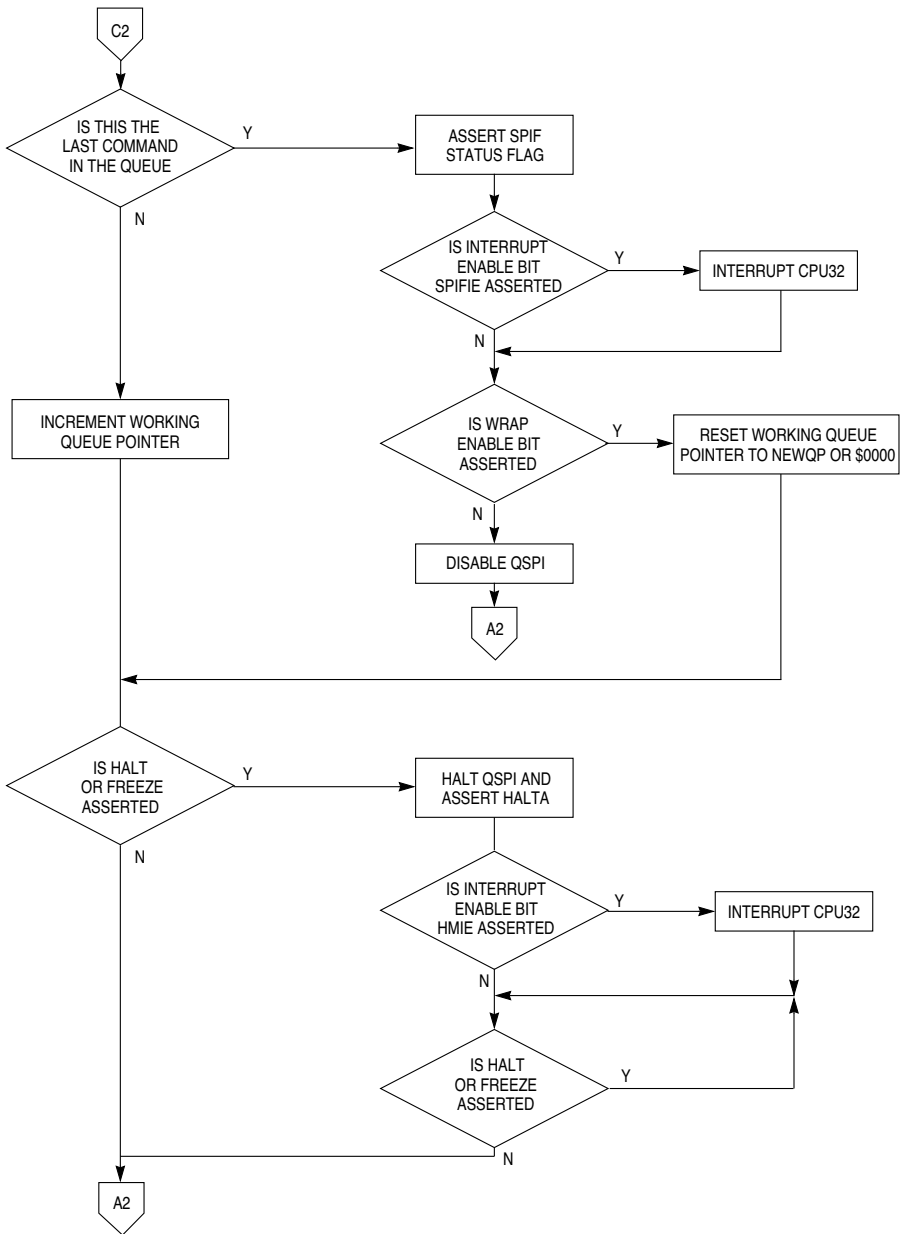

QSPI SLV2 FLOW6

Figure 9-9 Flowchart of QSPI Slave Operation (Part 2)

Normally, the SPI bus performs synchronous bidirectional transfers. The serial clock on the SPI bus master supplies the clock signal SCK to time the transfer of data. Four possible combinations of clock phase and polarity can be specified by the CPHA and CPOL bits in SPCR0.

Data is transferred with the most significant bit first. The number of bits transferred per command defaults to eight, but can be set to any value from eight to sixteen bits by writing a value into the BITSE field in command RAM.

Typically, SPI bus outputs are not open-drain unless multiple SPI masters are in the system. If needed, the WOMQ bit in SPCR0 can be set to provide wired-OR, open-drain outputs. An external pull-up resistor should be used on each output line. WOMQ affects all QSPI pins regardless of whether they are assigned to the QSPI or used as general-purpose I/O.

### 9.3.5.1 Master Mode

Setting the MSTR bit in SPCR0 selects master mode operation. In master mode, the QSPI can initiate serial transfers, but cannot respond to externally initiated transfers. When the slave select input of a device configured for master mode is asserted, a mode fault occurs.

Before QSPI operation begins, QSM register PQSPAR must be written to assign the necessary pins to the QSPI. The pins necessary for master mode operation are MISO and MOSI, SCK, and one or more of the chip-select pins. MISO is used for serial data input in master mode, and MOSI is used for serial data output. Either or both may be necessary, depending on the particular application. SCK is the serial clock output in master mode.

The PORTQS data register must next be written with values that make the PQS2/SCK and PQS[6:3]/PCS[3:0] outputs inactive when the QSPI completes a series of transfers. Pins allocated to the QSPI by PQSPAR are controlled by PORTQS when the QSPI is inactive. PORTQS I/O pins driven to states opposite those of the inactive QSPI signals can generate glitches that momentarily enable or partially clock a slave device. Thus, if a slave device operates with an inactive SCK state of logic one (CPOL = 1) and uses active low peripheral chip-select PCS0, the PQS[3:2] bits in PORTQS must be set to %11. If PQS[3:2] = %00, falling edges will appear on PQS2/SCK and PQS3/PCS0 as the QSPI relinquishes control of these pins and PORTQS drives them to logic zero from the inactive SCK and PCS0 states of logic one.

Before master mode operation is initiated, QSM register DDRQS is written last to direct the data flow on the QSPI pins used. Configure the SCK, MOSI and appropriate chip-select pins PCS[3:0] as outputs. The MISO pin must be configured as an input.

After pins are assigned and configured, write appropriate data to the command queue. If data is to be transmitted, write the data to transmit RAM. Initialize the queue pointers as appropriate.

Data transfer is synchronized with the internally-generated serial clock SCK. Control bits, CPHA and CPOL, in SPCR0, control clock phase and polarity. Combinations of CPHA and CPOL determine upon which SCK edge to drive outgoing data from the MOSI pin and to latch incoming data from the MISO pin.

Baud rate is selected by writing a value from 2 to 255 into SPBR[7:0] in SPCR0. The QSPI uses a modulus counter to derive SCK baud rate from the MCU system clock.

The following expressions apply to SCK baud rate:

$$\text{SCK Baud Rate} = \frac{\text{System Clock}}{2 \times \text{SPBR}[7:0]}$$

or

$$\text{SPBR}[7:0] = \frac{\text{System Clock}}{2 \times \text{SCK Baud Rate Desired}}$$

Giving SPBR[7:0] a value of zero or one disables the baud rate generator. SCK is disabled and assumes its inactive state value.

The DSCK bit in each command RAM byte inserts either a standard or user-specified delay from chip-select assertion until the leading edge of the serial clock. The DSCKL field in SPCR1 determines the length of the user-defined delay before the assertion of SCK. The following expression determines the actual delay before SCK:

$$\text{PCS to SCK Delay} = \frac{\text{DSCKL}[6:0]}{\text{System Clock}}$$

where DSCKL[6:0] equals {1,2,3,..., 127}.

When DSCK equals zero, DSCKL[6:0] is not used. Instead, the PCS valid-to-SCK transition is one-half the SCK period.

There are two transfer length options. The user can choose a default value of eight bits, or a programmed value of eight to sixteen bits, inclusive. The programmed value must be written into BITS[3:0] in SPCR0. The BITSE bit in each command RAM byte determines whether the default value (BITSE = 0) or the BITS value (BITSE = 1) is used. **Table 9-3** shows BITS[3:0] encoding.

**Table 9-3 Bits Per Transfer**

BITS[3:0]	Bits per Transfer
0000	16
0001	Reserved
0010	Reserved
0011	Reserved
0100	Reserved
0101	Reserved
0110	Reserved
0111	Reserved
1000	8
1001	9
1010	10
1011	11
1100	12
1101	13
1110	14
1111	15

Delay after transfer can be used to provide a peripheral deselect interval. A delay can also be inserted between consecutive transfers to allow serial A/D converters to complete conversion. Writing a value to DTL[7:0] in SPCR1 specifies a delay period. The DT bit in each command RAM byte determines whether the standard delay period (DT = 0) or the specified delay period (DT = 1) is used. The following expression is used to calculate the delay:

$$\text{Delay after Transfer} = \frac{32 \times \text{DTL}[7:0]}{\text{System Clock}}$$

where DTL equals {1, 2, 3, ..., 255}.

A zero value for DTL[7:0] causes a delay-after-transfer value of 8192/System Clock.

$$\text{Standard Delay after Transfer} = \frac{17}{\text{System Clock}}$$

Adequate delay between transfers must be specified for long data streams because the QSPI requires time to load a transmit RAM entry for transfer. Receiving devices need at least the standard delay between successive transfers. If the system clock is operating at a slower rate, the delay between transfers must be increased proportionately.

Operation is initiated by setting the SPE bit in SPCR1. Shortly after SPE is set, the QSPI executes the command at the command RAM address pointed to by NEWQP. Data at the pointer address in transmit RAM is loaded into the data serializer and transmitted. Data that is simultaneously received is stored at the pointer address in receive RAM.

When the proper number of bits have been transferred, the QSPI stores the working queue pointer value in CPTQP, increments the working queue pointer, and loads the next data for transfer from transmit RAM. The command pointed to by the incremented working queue pointer is executed next, unless a new value has been written to NEWQP. If a new queue pointer value is written while a transfer is in progress, that transfer is completed normally.

When the CONT bit in a command RAM byte is set, PCS pins are continuously driven in specified states during and between transfers. If the chip-select pattern changes during or between transfers, the original pattern is driven until execution of the following transfer begins. When CONT is cleared, the data in register PORTQS is driven between transfers. The data in PORTQS must match the inactive states of SCK and any peripheral chip-selects used.

When the QSPI reaches the end of the queue, it sets the SPIF flag. If the SPIFIE bit in SPCR2 is set, an interrupt request is generated when SPIF is asserted. At this point, the QSPI clears SPE and stops unless wrap-around mode is enabled.



### 9.3.5.2 Master Wrap-Around Mode

Wrap-around mode is enabled by setting the WREN bit in SPCR2. The queue can wrap to pointer address \$0 or to the address pointed to by NEWQP, depending on the state of the WRTO bit in SPCR2.

In wrap-around mode, the QSPI cycles through the queue continuously, even while the QSPI is requesting interrupt service. SPE is not cleared when the last command in the queue is executed. New receive data overwrites previously received data in receive RAM. Each time the end of the queue is reached, the SPIF flag is set. SPIF is not automatically reset. If interrupt-driven QSPI service is used, the service routine must clear the SPIF bit to end the current interrupt request. Additional interrupt requests during servicing can be prevented by clearing SPIFIE, but SPIFIE is buffered. Clearing it does not end the current request.

Wrap-around mode is exited by clearing the WREN bit or by setting the HALT bit in SPCR3. Exiting wrap-around mode by clearing SPE is not recommended, as clearing SPE may abort a serial transfer in progress. The QSPI sets SPIF, clears SPE, and stops the first time it reaches the end of the queue after WREN is cleared. After HALT is set, the QSPI finishes the current transfer, then stops executing commands. After the QSPI stops, SPE can be cleared.

### 9.3.5.3 Slave Mode

Clearing the MSTR bit in SPCR0 selects slave mode operation. In slave mode, the QSPI is unable to initiate serial transfers. Transfers are initiated by an external SPI bus master. Slave mode is typically used on a multi-master SPI bus. Only one device can be bus master (operate in master mode) at any given time.

Before QSPI operation is initiated, QSM register PQSPAR must be written to assign necessary pins to the QSPI. The pins necessary for slave mode operation are MISO and MOSI, SCK, and PCS0/ $\overline{SS}$ . MISO is used for serial data output in slave mode, and MOSI is used for serial data input. Either or both may be necessary, depending on the particular application. SCK is the serial clock input in slave mode. Assertion of the active-low slave select signal  $\overline{SS}$  initiates slave mode operation.

Before slave mode operation is initiated, DDRQS must be written to direct data flow on the QSPI pins used. Configure the MOSI, SCK and PCS0/ $\overline{SS}$  pins as inputs. The MISO pin must be configured as an output.

After pins are assigned and configured, write data to be transmitted into transmit RAM. Command RAM is not used in slave mode, and does not need to be initialized. Set the queue pointers, as appropriate.

When SPE is set and MSTR is clear, a low state on the slave select PCS0/ $\overline{SS}$  pin begins slave mode operation at the address indicated by NEWQP. Data that is received is stored at the pointer address in receive RAM. Data is simultaneously loaded into the data serializer from the pointer address in transmit RAM and transmitted. Transfer is synchronized with the externally generated SCK. The CPHA and CPOL bits determine upon which SCK edge to latch incoming data from the MISO pin and to drive outgoing data from the MOSI pin.

Because the command RAM is not used in slave mode, the CONT, BITSE, DT, DSCK, and peripheral chip-select bits have no effect. The PCS0/SS pin is used only as an input.

The SPBR, DT and DSCKL fields in SPCR0 and SPCR1 bits are not used in slave mode. The QSPI drives neither the clock nor the chip-select pins and thus cannot control clock rate or transfer delay.

Because the BITSE option is not available in slave mode, the BITS field in SPCR0 specifies the number of bits to be transferred for all transfers in the queue. When the number of bits designated by BITS[3:0] has been transferred, the QSPI stores the working queue pointer value in CPTQP, increments the working queue pointer, and loads new transmit data from transmit RAM into the data serializer. The working queue pointer address is used the next time PCS0/SS is asserted, unless the CPU32 writes to NEWQP first.

The QSPI shifts one bit for each pulse of SCK until the slave select input goes high. If SS goes high before the number of bits specified by the BITS field is transferred, the QSPI resumes operation at the same pointer address the next time SS is asserted. The maximum value that the BITS field can have is 16. If more than 16 bits are transmitted before SS is negated, pointers are incremented and operation continues.

The QSPI transmits as many bits as it receives at each queue address, until the BITS value is reached or SS is negated. SS does not need to go high between transfers as the QSPI transfers data until reaching the end of the queue, whether SS remains low or is toggled between transfers.

When the QSPI reaches the end of the queue, it sets the SPIF flag. If the SPIFIE bit in SPCR2 is set, an interrupt request is generated when SPIF is asserted. At this point, the QSPI clears SPE and stops unless wrap-around mode is enabled.

#### 9.3.5.4 Slave Wrap-Around Mode

Slave wrap-around mode is enabled by setting the WREN bit in SPCR2. The queue can wrap to pointer address \$0 or to the address pointed to by NEWQP, depending on the state of the WRTO bit in SPCR2. Slave wrap-around operation is identical to master wrap-around operation.

#### 9.3.6 Peripheral Chip Selects

Peripheral chip-select signals are used to select an external device for serial data transfer. Chip-select signals are asserted when a command in the queue is executed. Signals are asserted at a logic level corresponding to the value of the PCS[3:0] bits in each command byte. More than one chip-select signal can be asserted at a time, and more than one external device can be connected to each PCS pin, provided proper fanout is observed. PCS0 shares a pin with the slave select SS signal, which initiates slave mode serial transfer. If SS is taken low when the QSPI is in master mode, a mode fault occurs.

To configure a peripheral chip-select, set the appropriate bit in PQSPAR, then configure the chip-select pin as an output by setting the appropriate bit in DDRQS. The value of the bit in PORTQS that corresponds to the chip-select pin determines the base state of the chip-select signal. If base state is zero, chip-select assertion must be active high (PCS bit in command RAM must be set); if base state is one, assertion must be active low (PCS bit in command RAM must be cleared). PORTQS bits are cleared during reset. If no new data is written to PORTQS before pin assignment and configuration as an output, base state of chip-select signals is zero and chip-select pins are configured for active-high operation.

## 9.4 Serial Communication Interface

The serial communication interface (SCI) communicates with external devices through an asynchronous serial bus. The SCI uses a standard non-return to zero (NRZ) transmission format. The SCI is fully compatible with other Motorola SCI systems, such as those on M68HC11 and M68HC05 devices. **Figure 9-10** is a block diagram of the SCI transmitter. **Figure 9-11** is a block diagram of the SCI receiver.

### 9.4.1 SCI Registers

The SCI programming model includes the QSM global and pin control registers, and four SCI registers. There are two SCI control registers (SCCR0 and SCCR1), one status register (SCSR), and one data register (SCDR). Refer to **D.6 Queued Serial Module** for register bit and field definitions.

#### 9.4.1.1 Control Registers

SCCR0 contains the baud rate selection field. Baud rate must be set before the SCI is enabled. This register can be read or written.

SCCR1 contains a number of SCI configuration parameters, including transmitter and receiver enable bits, interrupt enable bits, and operating mode enable bits. This register can be read or written at any time. The SCI can modify the RWU bit under certain circumstances.

Changing the value of SCI control bits during a transfer may disrupt operation. Before changing register values, allow the SCI to complete the current transfer, then disable the receiver and transmitter.





### 9.4.1.2 Status Register

SCSR contains flags that show SCI operating conditions. These flags are cleared either by SCI hardware or by reading SCSR, then reading or writing SCDR. A long-word read can consecutively access both SCSR and SCDR. This action clears receiver status flag bits that were set at the time of the read, but does not clear TDRE or TC flags.

If an internal SCI signal for setting a status bit comes after reading the asserted status bits, but before reading or writing SCDR, the newly set status bit is not cleared. SCSR must be read again with the bit set, and SCDR must be read or written before the status bit is cleared.

Reading either byte of SCSR causes all 16 bits to be accessed, and any status bit already set in either byte is cleared on a subsequent read or write of SCDR.

### 9.4.1.3 Data Register

SCDR contains two data registers at the same address. The receive data register (RDR) is a read-only register that contains data received by the SCI serial interface. Data enters the receive serial shifter and is transferred to RDR. The transmit data register (TDR) is a write-only register that contains data to be transmitted. Data is first written to TDR, then transferred to the transmit serial shifter, where additional format bits are added before transmission. R[7:0]/T[7:0] contain either the first eight data bits received when SCDR is read, or the first eight data bits to be transmitted when SCDR is written. R8/T8 are used when the SCI is configured for 9-bit operation. When it is configured for 8-bit operation, they have no meaning or effect.

### 9.4.2 SCI Pins

Two unidirectional pins, TXD (transmit data) and RXD (receive data), are associated with the SCI. TXD can be used by the SCI or for general-purpose I/O. Function is assigned by the port QS pin assignment register (PQSPAR). The receive data (RXD) pin is dedicated to the SCI. **Table 9-4** shows SCI pin function.

**Table 9-4 SCI Pins**

Pin Names	Mnemonics	Mode	Function
Receive Data	RXD	Receiver disabled Receiver enabled	Not used Serial data input to SCI
Transmit Data	TXD	Transmitter disabled Transmitter enabled	General-purpose I/O Serial data output from SCI

### 9.4.3 SCI Operation

SCI operation can be polled by means of status flags in SCSR, or interrupt-driven operation can be employed by the interrupt enable bits in SCCR1.

### 9.4.3.1 Definition of Terms

- Bit-Time — The time required to transmit or receive one bit of data, which is equal to one cycle of the baud frequency.
- Start Bit — One bit-time of logic zero that indicates the beginning of a data frame. A start bit must begin with a one-to-zero transition and be preceded by at least three receive time samples of logic one.
- Stop Bit— One bit-time of logic one that indicates the end of a data frame.
- Frame — A complete unit of serial information. The SCI can use 10-bit or 11-bit frames.
- Data Frame — A start bit, a specified number of data or information bits, and at least one stop bit.
- Idle Frame — A frame that consists of consecutive ones. An idle frame has no start bit.
- Break Frame — A frame that consists of consecutive zeros. A break frame has no stop bits.

### 9.4.3.2 Serial Formats

All data frames must have a start bit and at least one stop bit. Receiving and transmitting devices must use the same data frame format. The SCI provides hardware support for both 10-bit and 11-bit frames. The M bit in SCCR1 specifies the number of bits per frame.

The most common data frame format for NRZ serial interfaces is one start bit, eight data bits (LSB first), and one stop bit; a total of ten bits. The most common 11-bit data frame contains one start bit, eight data bits, a parity or control bit, and one stop bit. Ten-bit and eleven-bit frames are shown in **Table 9-5**.

**Table 9-5 Serial Frame Formats**

10-Bit Frames			
Start	Data	Parity/Control	Stop
1	7	—	2
1	7	1	1
1	8	—	1
11-Bit Frames			
Start	Data	Parity/Control	Stop
1	7	1	2
1	8	1	1

### 9.4.3.3 Baud Clock

The SCI baud rate is programmed by writing a 13-bit value to the SCBR field in SCI control register zero (SCCR0). The baud rate is derived from the MCU system clock by a modulus counter. Writing a value of zero to SCBR[12:0] disables the baud rate generator. Baud rate is calculated as follows:

$$\text{SCI Baud Rate} = \frac{\text{System Clock}}{32 \times \text{SCBR}[12:0]}$$

or

$$\text{SCBR}[12:0] = \frac{\text{System Clock}}{32 \times \text{SCI Baud Rate Desired}}$$

where SCBR[12:0] is in the range {1, 2, 3, ..., 8191}.

The SCI receiver operates asynchronously. An internal clock is necessary to synchronize with an incoming data stream. The SCI baud rate generator produces a receive time sampling clock with a frequency 16 times that of the SCI baud rate. The SCI determines the position of bit boundaries from transitions within the received waveform, and adjusts sampling points to the proper positions within the bit period.

#### 9.4.3.4 Parity Checking

The PT bit in SCCR1 selects either even (PT = 0) or odd (PT = 1) parity. PT affects received and transmitted data. The PE bit in SCCR1 determines whether parity checking is enabled (PE = 1) or disabled (PE = 0). When PE is set, the MSB of data in a frame is used for the parity function. For transmitted data, a parity bit is generated for received data; the parity bit is checked. When parity checking is enabled, the PF bit in the SCI status register (SCSR) is set if a parity error is detected.

Enabling parity affects the number of data bits in a frame, which can in turn affect frame size. **Table 9-6** shows possible data and parity formats.

**Table 9-6 Effect of Parity Checking on Data Size**

M	PE	Result
0	0	8 data bits
0	1	7 data bits, 1 parity bit
1	0	9 data bits
1	1	8 data bits, 1 parity bit

#### 9.4.3.5 Transmitter Operation

The transmitter consists of a serial shifter and a parallel data register (TDR) located in the SCI data register (SCDR). The serial shifter cannot be directly accessed by the CPU32. The transmitter is double-buffered, which means that data can be loaded into the TDR while other data is shifted out. The TE bit in SCCR1 enables (TE = 1) and disables (TE = 0) the transmitter.

Shifter output is connected to the TXD pin while the transmitter is operating (TE = 1, or TE = 0 and transmission in progress). Wired-OR operation should be specified when more than one transmitter is used on the same SCI bus. The WOMS bit in SCCR1 determines whether TXD is an open-drain (wired-OR) output or a normal CMOS output. An external pull-up resistor on TXD is necessary for wired-OR operation. WOMS controls TXD function whether the pin is used by the SCI or as a general-purpose I/O pin.



Data to be transmitted is written to SCDR, then transferred to the serial shifter. The transmit data register empty (TDRE) flag in SCSR shows the status of TDR. When TDRE = 0, the TDR contains data that has not been transferred to the shifter. Writing to SCDR again overwrites the data. TDRE is set when the data in the TDR is transferred to the shifter. Before new data can be written to the SCDR, however, the processor must clear TDRE by writing to SCSR. If new data is written to the SCDR without first clearing TDRE, the data will not be transmitted.

The transmission complete (TC) flag in SCSR shows transmitter shifter state. When TC = 0, the shifter is busy. TC is set when all shifting operations are completed. TC is not automatically cleared. The processor must clear it by first reading SCSR while TC is set, then writing new data to SCDR.

The state of the serial shifter is checked when the TE bit is set. If TC = 1, an idle frame is transmitted as a preamble to the following data frame. If TC = 0, the current operation continues until the final bit in the frame is sent, then the preamble is transmitted. The TC bit is set at the end of preamble transmission.

The SBK bit in SCCR1 is used to insert break frames in a transmission. A non-zero integer number of break frames is transmitted while SBK is set. Break transmission begins when SBK is set, and ends with the transmission in progress at the time either SBK or TE is cleared. If SBK is set while a transmission is in progress, that transmission finishes normally before the break begins. To assure the minimum break time, toggle SBK quickly to one and back to zero. The TC bit is set at the end of break transmission. After break transmission, at least one bit-time of logic level one (mark idle) is transmitted to ensure that a subsequent start bit can be detected.

If TE remains set, after all pending idle, data and break frames are shifted out, TDRE and TC are set and TXD is held at logic level one (mark).

When TE is cleared, the transmitter is disabled after all pending idle; data and break frames are transmitted. The TC flag is set, and control of the TXD pin reverts to PQSPAR and DDRQS. Buffered data is not transmitted after TE is cleared. To avoid losing data in the buffer, do not clear TE until TDRE is set.

Some serial communication systems require a mark on the TXD pin even when the transmitter is disabled. Configure the TXD pin as an output, then write a one to PQS7. When the transmitter releases control of the TXD pin, it reverts to driving a logic one output.

To insert a delimiter between two messages, to place non-listening receivers in wake-up mode between transmissions, or to signal a retransmission by forcing an idle line, clear and then set TE before data in the serial shifter has shifted out. The transmitter finishes the transmission, then sends a preamble. After the preamble is transmitted, if TDRE is set, the transmitter will mark idle. Otherwise, normal transmission of the next sequence will begin.

Both TDRE and TC have associated interrupts. The interrupts are enabled by the transmit interrupt enable (TIE) and transmission complete interrupt enable (TCIE) bits in SCCR1. Service routines can load the last byte of data in a sequence into SCDR, then terminate the transmission when a TDRE interrupt occurs.

### 9.4.3.6 Receiver Operation

The RE bit in SCCR1 enables (RE = 1) and disables (RE = 0) the receiver. The receiver contains a receive serial shifter and a parallel receive data register (RDR) located in the SCI data register (SCDR). The serial shifter cannot be directly accessed by the CPU32. The receiver is double-buffered, allowing data to be held in the RDR while other data is shifted in.

Receiver bit processor logic drives a state machine that determines the logic level for each bit-time. This state machine controls when the bit processor logic is to sample the RXD pin and also controls when data is to be passed to the receive serial shifter. A receive time clock is used to control sampling and synchronization. Data is shifted into the receive serial shifter according to the most recent synchronization of the receive time clock with the incoming data stream. From this point on, data movement is synchronized with the MCU system clock. Operation of the receiver state machine is detailed in the *QSM Reference Manual* (QSMRM/AD).

The number of bits shifted in by the receiver depends on the serial format. However, all frames must end with at least one stop bit. When the stop bit is received, the frame is considered to be complete, and the received data in the serial shifter is transferred to the RDR. The receiver data register flag (RDRF) is set when the data is transferred.

Noise errors, parity errors, and framing errors can be detected while a data stream is being received. Although error conditions are detected as bits are received, the noise flag (NF), the parity flag (PF), and the framing error (FE) flag in SCSR are not set until data is transferred from the serial shifter to the RDR.

RDRF must be cleared before the next transfer from the shifter can take place. If RDRF is set when the shifter is full, transfers are inhibited and the overrun error (OR) flag in SCSR is set. OR indicates that the RDR needs to be serviced faster. When OR is set, the data in the RDR is preserved, but the data in the serial shifter is lost. Because framing, noise, and parity errors are detected while data is in the serial shifter, FE, NF, and PF cannot occur at the same time as OR.

When the CPU32 reads SCSR and SCDR in sequence, it acquires status and data, and also clears the status flags. Reading SCSR acquires status and arms the clearing mechanism. Reading SCDR acquires data and clears SCSR.

When RIE in SCCR1 is set, an interrupt request is generated whenever RDRF is set. Because receiver status flags are set at the same time as RDRF, they do not have separate interrupt enables.

### 9.4.3.7 Idle-Line Detection

During a typical serial transmission, frames are transmitted isochronally and no idle time occurs between frames. Even when all the data bits in a frame are logic ones, the start bit provides one logic zero bit-time during the frame. An idle line is a sequence of contiguous ones equal to the current frame size. Frame size is determined by the state of the M bit in SCCR1.

The SCI receiver has both short and long idle-line detection capability. Idle-line detection is always enabled. The idle line type (ILT) bit in SCCR1 determines which type of detection is used. When an idle line condition is detected, the IDLE flag in SCSR is set.

For short idle-line detection, the receiver bit processor counts contiguous logic one bit-times whenever they occur. Short detection provides the earliest possible recognition of an idle line condition, because the stop bit and contiguous logic ones before and after it are counted. For long idle-line detection, the receiver counts logic ones after the stop bit is received. Only a complete idle frame causes the IDLE flag to be set.

In some applications, software overhead can cause a bit-time of logic level one to occur between frames. This bit-time does not affect content, but if it occurs after a frame of ones when short detection is enabled, the receiver flags an idle line.

When the ILIE bit in SCCR1 is set, an interrupt request is generated when the IDLE flag is set. The flag is cleared by reading SCSR and SCDR in sequence. IDLE is not set again until after at least one frame has been received (RDRF = 1). This prevents an extended idle interval from causing more than one interrupt.

#### **9.4.3.8 Receiver Wake-Up**

The receiver wake-up function allows a transmitting device to direct a transmission to a single receiver or to a group of receivers by sending an address frame at the start of a message. Hardware activates each receiver in a system under certain conditions. Resident software must process address information and enable or disable receiver operation.

A receiver is placed in wake-up mode by setting the RWU bit in SCCR1. While RWU is set, receiver status flags and interrupts are disabled. Although the CPU32 can clear RWU, it is normally cleared by hardware during wake-up.

The WAKE bit in SCCR1 determines which type of wake-up is used. When WAKE = 0, idle-line wake-up is selected. When WAKE = 1, address-mark wake-up is selected. Both types require a software-based device addressing and recognition scheme.

Idle-line wake-up allows a receiver to sleep until an idle line is detected. When an idle-line is detected, the receiver clears RWU and wakes up. The receiver waits for the first frame of the next transmission. The byte is received normally, transferred to the RDR, and the RDRF flag is set. If software does not recognize the address, it can set RWU and put the receiver back to sleep. For idle-line wake-up to work, there must be a minimum of one frame of idle line between transmissions. There must be no idle time between frames within a transmission.

Address-mark wake-up uses a special frame format to wake up the receiver. When the MSB of an address-mark frame is set, that frame contains address information. The first frame of each transmission must be an address frame. When the MSB of a frame is set, the receiver clears RWU and wakes up. The byte is received normally, transferred to the RDR, and the RDRF flag is set. If software does not recognize the address, it can set RWU and put the receiver back to sleep. Address-mark wake-up allows idle time between frames and eliminates idle time between transmissions. However, there is a loss of efficiency because of an additional bit-time per frame.

### 9.4.3.9 Internal Loop

The LOOPS bit in SCCR1 controls a feedback path in the data serial shifter. When LOOPS is set, the SCI transmitter output is fed back into the receive serial shifter. TXD is asserted (idle line). Both transmitter and receiver must be enabled before entering loop mode.

## 9.5 QSM Initialization

After reset, the QSM remains in an idle state until initialized. A general guide for initialization follows.

- A. Global
  1. Configuration QSMCR
    - a. Write an interrupt arbitration priority value into the IARB field.
    - b. Clear the FREEZE and/or STOP bits for normal operation.
  2. Configure QIVR and QILR
    - a. Write QSPI/SCI interrupt vector number into QIVR.
    - b. Write QSPI (ILSPI) and SCI (ILSCI) interrupt priorities into QILR.
  3. Configure PORTQS and DDRQS
    - a. Write a data word to PORTQS.
    - b. Set the direction of QSM pins used for I/O by writing to DDRQS.
  4. Assign pin functions by writing to the pin assignment register PQSPAR
- B. Queued Serial Peripheral Interface
  1. Write appropriate values to QSPI command RAM and transmit RAM.
  2. Set up the SPCR0
    - a. Set the bit in with the BR field.
    - b. Determine clock phase (CPHA), and clock polarity (CPOL).
    - c. Determine number of bits to be transferred in a serial operation (BITS[3:0]).
    - d. Select master or slave operating mode (MSTR).
    - e. Enable or disable wired-OR operation (WOMQ).
  3. Set up SPCR1
    - a. Establish a delay following serial transfer by writing to the DTL field.
    - b. Establish a delay before serial transfer by writing to the DSCKL field.
  4. Set up SPCR2
    - a. Write an initial queue pointer value into the NEWQP field.
    - b. Write a final queue pointer value into the ENDQP field.
    - c. Enable or disable queue wrap-around (WREN).
    - d. Set wrap-around address if enabled (WRTO).
    - e. Enable or disable QSPI interrupt (SPIFIE).
  5. Set up SPCR3
    - a. Enable or disable halt at end of queue (HALT).
    - b. Enable or disable halt and mode fault interrupts (HMIE).
    - c. Enable or disable loopback (LOOPQ).
  6. To enable the QSPI, set the SPE bit in SPCR1.
- C. Serial Communication Interface
  1. Set up SCCR0
    - a. Set the baud with the SCBR field.

2. Set up SCCR1
  - a. Select serial mode (M)
  - b. Enable use (PE) and type (PT) of parity check.
  - c. Select use (RWU) and type (WAKE) of receiver wake-up.
  - d. Enable idle-line detection (ILT) and interrupt (ILIE).
  - e. Enable or disable wired-OR operation (WOMS).
  - f. Enable or disable break transmission (SBK).
3. To receive:
  - a. Set the receiver (RE) and receiver interrupt (RIE) bits in SCCR1.
4. To transmit:
  - a. Set transmitter (TE) and transmitter interrupt (TIE) bits in SCCR1.
  - b. Clear the TDRE and TC flags by reading SCSR and writing data to SCDR.



## SECTION 8 QUEUED ANALOG-TO-DIGITAL CONVERTER MODULE

This section is an overview of the queued analog-to-digital converter (QADC) module. Refer to the *QADC Reference Manual (QADCRM/AD)* for a comprehensive discussion of QADC capabilities.

### 8.1 General

The QADC consists of an analog front-end and a digital control subsystem, which includes an intermodule bus (IMB) interface block. Refer to **Figure 8-1**.

The analog section includes input pins, an analog multiplexer, and two sample and hold analog circuits. The analog conversion is performed by the digital-to-analog converter (DAC) resistor-capacitor array and a high-gain comparator.

The digital control section contains the conversion sequencing logic, channel selection logic, and a successive approximation register (SAR). Also included are the periodic/interval timer, control and status registers, the conversion command word (CCW) table RAM, and the result word table RAM.

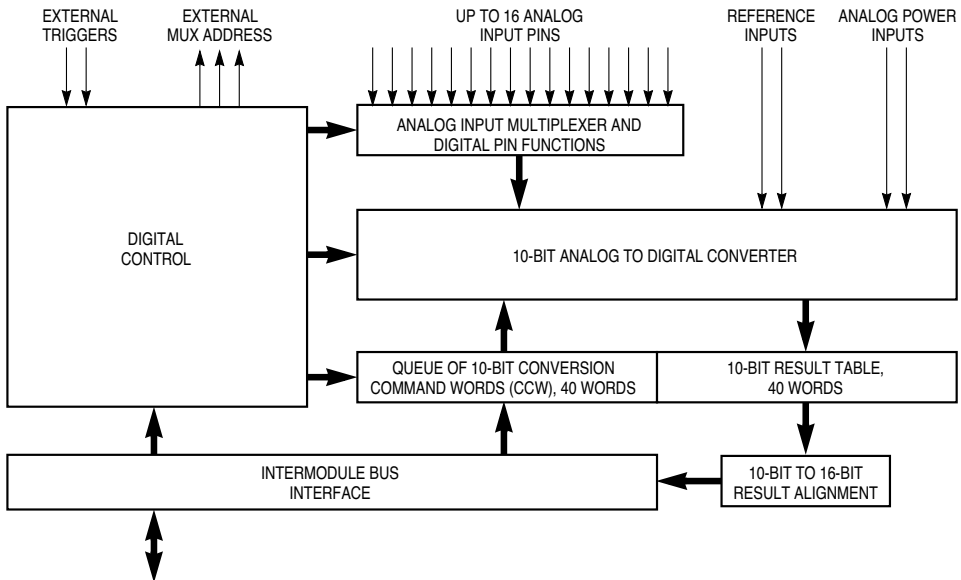

QADC BLOCK

**Figure 8-1 QADC Block Diagram**

## 8.2 QADC Address Map

The QADC occupies 512 bytes of address space. Nine words are control, port, and status registers, 40 words are the CCW table, and 120 words are the result word table because 40 result registers can be read in three data alignment formats. The remaining words are reserved for expansion. Refer to **D.5 QADC Module** for information concerning the QADC address map.

## 8.3 QADC Registers

The QADC has three global registers for configuring module operation: the module configuration register (QADCMCR), the interrupt register (QADCINT), and a test register (QADCTEST). The global registers are always defined to be in supervisor data space. The CPU32 allows software to establish the global registers in supervisor data space and the remaining registers and tables in user space.

All QADC analog channel/port pins that are not used for analog input channels can be used as digital port pins. Port values are read/written by accessing the port A and B data registers (PORTQA and PORTQB). Port A pins are specified as inputs or outputs by programming the port data direction register (DDRQA). Port B is an input only port.

The four remaining control registers configure the operation of the queuing mechanism, and provide a means of monitoring the operation of the QADC. Control register 0 (QACR0) contains hardware configuration information. Control register 1 (QACR1) is associated with queue 1, and control register 2 (QACR2) is associated with queue 2. The status register (QASR) provides visibility on the status of each queue and the particular conversion that is in progress.

Following the register block in the address map is the CCW table. There are 40 words to hold the desired analog conversion sequences. Each CCW is a 16-bit word, with ten implemented bits in four fields. Refer to **D.5.8 Conversion Command Word Table** for more information.

The final block of address space belongs to the result word table, which appears in three places in the memory map. Each result word table location holds one 10-bit conversion value. The software selects one of three data formats, which map the 10-bit result onto the 16-bit data bus by reading the address which produces the desired alignment. The first address block presents the result data in right justified format, the second block is presented in left justified signed format, and the third is presented in left justified unsigned format. Refer to **D.5.9 Result Word Table** for more information.

## 8.4 QADC Pin Functions

The QADC uses a maximum of 21 external pins. There are 16 channel/port pins that can support up to 41 channels when external multiplexing is used (including internal channels). All of the channel pins can also be used as general-purpose digital port pins.

In addition, there are also two analog reference pins, two analog submodule power pins, and one  $V_{SS}$  pin for the open drain output drivers on port A.



The QADC allows external trigger inputs and the multiplexer outputs to be combined onto some of the channel pins. All of the channel pins are used for at least two functions, depending on the modes in use.

The following paragraphs describe QADC pin functions. **Figure 8-2** shows the QADC module pins.

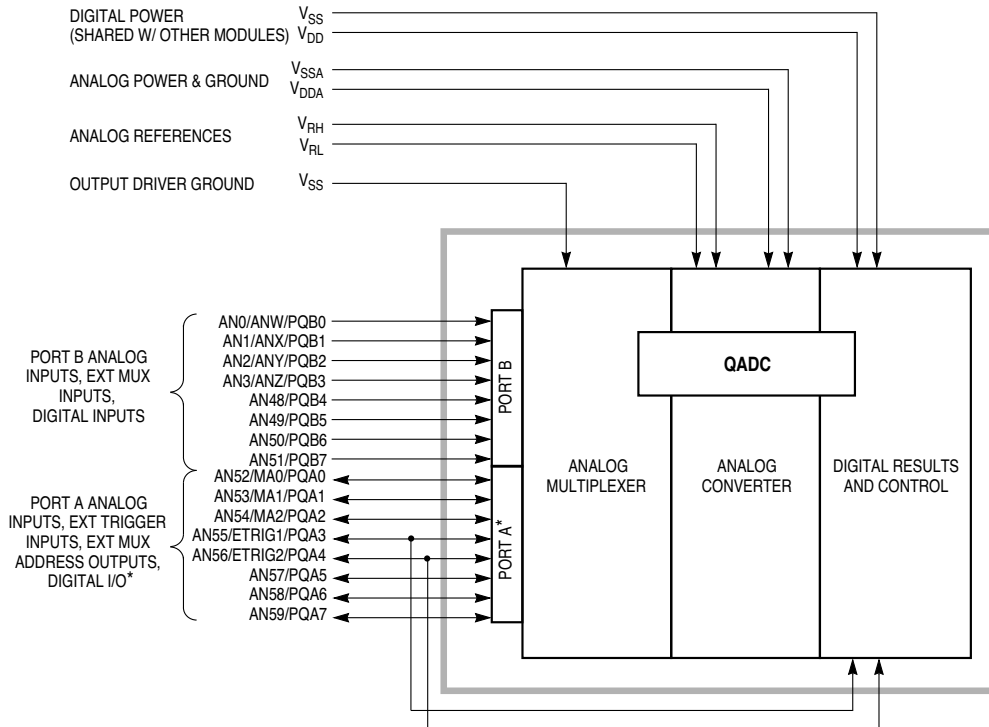

\* PORT A PINS INCORPORATE OPEN DRAIN PULL DOWN DRIVERS.

QADC PINOUT

**Figure 8-2 QADC Input and Output Signals**

### 8.4.1 Port A Pin Functions

The eight port A pins can be used as analog inputs, or as a bidirectional 8-bit digital input/output port. Refer to the following paragraphs for more information.

### 8.4.1.1 Port A Analog Input Pins

When used as analog inputs, the eight port A pins are referred to as AN[59:52]. Due to the digital output drivers associated with port A, the analog characteristics of port A are different from those of port B. All of the analog signal input pins may be used for at least one other purpose.

### 8.4.1.2 Port A Digital Input/Output Pins

Port A pins are referred to as PQA[7:0] when used as a bidirectional 8-bit digital input/output port. These eight pins may be used for general-purpose digital input signals or digital open drain pull-down output signals.

Port A pins are connected to a digital input synchronizer during reads and may be used as general purpose digital inputs.

Each port A pin is configured as an input or output by programming the port data direction register (DDRQA). Digital input signal states are read from the PORTQA data register when DDRQA specifies that the pins are inputs. Digital data in PORTQA is driven onto the port A pins when the corresponding bits in DDRQA specify outputs. Refer to **D.5.5 Port Data Direction Register** for more information. Since the outputs are open drain drivers (so as to minimize the effects to the analog function of the pins), external pull-up resistors must be used when port A pins are used to drive another device.

## 8.4.2 Port B Pin Functions

The eight port B pins can be used as analog inputs, or as an 8-bit digital input only port. Refer to the following paragraphs for more information.

### 8.4.2.1 Port B Analog Input Pins

When used as analog inputs, the eight port B pins are referred to as AN[51:48]/AN[3:0]. Since port B functions as analog and digital input only, the analog characteristics are different from those of port A. Refer to **APPENDIX A ELECTRICAL CHARACTERISTICS** for more information on analog signal characteristics. All of the analog signal input pins may be used for at least one other purpose.

### 8.4.2.2 Port B Digital Input Pins

Port B pins are referred to as PQB[7:0] when used as an 8-bit digital input only port. In addition to functioning as analog input pins, the port B pins are also connected to the input of a synchronizer during reads and may be used as general-purpose digital inputs.

Since port B pins are input only, there is no associated data direction register. Digital input signal states are read from the PORTQB data register. Refer to **D.5.5 Port Data Direction Register** for more information.

### 8.4.3 External Trigger Input Pins

The QADC has two external trigger pins (ETRIG[2:1]). The external trigger pins share two multifunction port A pins (PQA[4:3]), which are normally used as analog channel input pins. Each of the two external trigger pins is associated with one of the scan queues. When a queue is in external trigger mode, the corresponding external trigger pin is configured as a digital input and the software programmed input/output direction for that pin is ignored. Refer to **D.5.5 Port Data Direction Register** for more information.

### 8.4.4 Multiplexed Address Output Pins

In non-multiplexed mode, the 16 channel pins are connected to an internal multiplexer which routes the analog signals into the A/D converter.

In externally multiplexed mode, the QADC allows automatic channel selection through up to four external 1-of-8 multiplexer chips. The QADC provides a 3-bit multiplexed address output to the external mux chips to allow selection of one of eight inputs. The multiplexed address output signals MA[2:0] can be used as multiplex address output bits or as general-purpose I/O.

MA[2:0] are used as the address inputs for up to four 1-of-8 multiplexer chips (for example, the MC14051 and the MC74HC4051). Since MA[2:0] are digital outputs in multiplexed mode, the software programmed input/output direction for these pins in DDRQA is ignored.

### 8.4.5 Multiplexed Analog Input Pins

In externally multiplexed mode, four of the port B pins are redefined to each represent a group of eight input channels. Refer to **Table 8-1**.

The analog output of each external multiplexer chip is connected to one of the AN[w, x, y, z] inputs in order to convert a channel selected by the MA[2:0] multiplexed address outputs.

**Table 8-1 Multiplexed Analog Input Channels**

Multiplexed Analog Input	Channels
ANw	Even numbered channels from 0 to 14
ANx	Odd numbered channels from 1 to 15
ANy	Even channels from 16 to 30
ANz	Odd channels from 17 to 31

### 8.4.6 Voltage Reference Pins

$V_{RH}$  and  $V_{RL}$  are the dedicated input pins for the high and low reference voltages. Separating the reference inputs from the power supply pins allows for additional external filtering, which increases reference voltage precision and stability, and subsequently contributes to a higher degree of conversion accuracy. Refer to **Tables A-11** and **A-12** for more information.

### 8.4.7 Dedicated Analog Supply Pins

$V_{DDA}$  and  $V_{SSA}$  pins supply power to the analog subsystems of the QADC module. Dedicated power is required to isolate the sensitive analog circuitry from the normal levels of noise present on the digital power supply. Refer to **Tables A-11** and **A-12** for more information.

### 8.4.8 External Digital Supply Pin

Each port A pin includes a digital open drain output driver, an analog input signal path, and a digital input synchronizer. The  $V_{SS}$  pin provides the ground level for the drivers on the port A pins. Since the QADC output pins have open drain type drivers, a dedicated  $V_{DD}$  pin is not needed.

### 8.4.9 Digital Supply Pins

$V_{DD}$  and  $V_{SS}$  provide the power for the digital portions of the QADC, and for all other digital MCU modules.

## 8.5 QADC Bus Interface

The QADC can respond to byte, word, and long word accesses, however, coherency is not provided for accesses that require more than one bus cycle.

For example, if a long word read of two consecutive result registers is initiated, the QADC could change one of the result registers between the bus cycles required for each register read. All read and write accesses that require more than one 16-bit access to complete occur as two or more independent bus cycles.

Normal reads from and writes to the QADC require two clock cycles. However, if the CPU32 tries to access locations that are also accessible to the QADC while the QADC is accessing them, the bus cycle will require additional clock cycles. The QADC may insert from one to four wait states in the process of a CPU32 read from or write to such a location.

## 8.6 Module Configuration

The QADC module configuration register (QADCMCR) defines freeze and stop mode operation, supervisor space access, and interrupt arbitration priority. Unimplemented bits read zero and writes have no effect. QADCMCR is typically written once when software initializes the QADC, and not changed thereafter. Refer to **D.5.1 QADC Module Configuration Register** for register and bit descriptions.

### 8.6.1 Low-Power Stop Mode

When the STOP bit in QADCMCR is set, the clock signal to the A/D converter is disabled, effectively turning off the analog circuitry. This results in a static, low power consumption, idle condition. Low-power stop mode aborts any conversion sequence in progress. Because the bias currents to the analog circuits are turned off in low-power stop mode, the QADC requires some recovery time ( $t_{SR}$  in **APPENDIX A ELECTRICAL CHARACTERISTICS**) to stabilize the analog circuits after the STOP bit is cleared.

In the low-power stop mode, QADCMCR, the interrupt register (QADCINT), and the test register (QADCTEST) are not reset and fully accessible. The data direction register (DDRQA) and port data registers (PORTQA and PORTQB) are not reset and are read-only accessible. Control register 0 (QACR0), control register 1 (QACR1), control register 2 (QACR2), and status register (QASR) are reset and are read-only accessible. The CCW table and result table are not reset and not accessible. In addition, the QADC clock (QCLK) and the periodic/interval timer are held in reset during low-power stop mode.

If the STOP bit is clear, low-power stop mode is disabled. Refer to **D.5.1 QADC Module Configuration Register** for more information.

### 8.6.2 Freeze Mode

The QADC enters freeze mode when background debug mode is enabled and a breakpoint is processed. This is indicated by assertion of the FREEZE line on the IMB. The FRZ bit in QADCMCR determines whether or not the QADC responds to an IMB FREEZE assertion. Freeze mode is useful when debugging an application.

When the IMB FREEZE line is asserted and the FRZ bit is set, the QADC finishes any conversion in progress and then freezes. Depending on when the FREEZE is asserted, there are three possible queue freeze scenarios:

- When a queue is not executing, the QADC freezes immediately.
- When a queue is executing, the QADC completes the current conversion and then freezes.
- If during the execution of the current conversion, the queue operating mode for the active queue is changed, or a queue 2 abort occurs, the QADC freezes immediately.

When the QADC enters the freeze mode while a queue is active, the current CCW location of the queue pointer is saved.

In freeze mode, the analog logic is held in reset and is not clocked. Although QCLK is unaffected, the periodic/interval timer is held in reset. External trigger events that occur during freeze mode are not recorded. The CPU32 may continue to access all QADC registers, the CCW table, and the result table. Although the QADC saves a pointer to the next CCW in the current queue, software can force the QADC to execute a different CCW by writing new queue operating modes before normal operation resumes. The QADC looks at the queue operating modes, the current queue pointer, and any pending trigger events to decide which CCW to execute.

If the FRZ bit is clear, assertion of the IMB FREEZE line is ignored. Refer to **D.5.1 QADC Module Configuration Register** for more information.

### 8.6.3 Supervisor/Unrestricted Address Space

The QADC memory map is divided into two segments: supervisor-only data space and assignable data space. Access to supervisor-only data space is permitted only when the CPU32 is operating in supervisor mode. Assignable data space can have either restricted to supervisor-only data space access or unrestricted supervisor and user

data space accesses. The SUPV bit in QADCMCR designates the assignable space as supervisor or unrestricted.

Attempts to read supervisor-only data space when the CPU32 is not in supervisor mode causes a value of \$0000 to be returned. Attempts to read assignable data space when the CPU32 is not in supervisor mode and when the space is programmed as supervisor space, causes a value of \$FFFF to be returned. Attempts to write supervisor-only or supervisor-assigned data space when the CPU32 is in user mode has no effect.

The supervisor-only data space segment contains the QADC global registers, which include QADCMCR, QADCTEST, and QADCINT. The supervisor/unrestricted space designation for the CCW table, the result word table, and the remaining QADC registers is programmable. Refer to **D.5.1 QADC Module Configuration Register** for more information.

#### 8.6.4 Interrupt Arbitration Priority

Each module that can request interrupts, including the QADC, has an interrupt arbitration number (IARB) field in its module configuration register. Each IARB field must have a different non-zero value. During an interrupt acknowledge cycle, IARB permits arbitration among simultaneous interrupts of the same priority level.

The reset value of IARB in the QADCMCR is \$0. Initialization software must set the IARB field to a non-zero value in order for QADC interrupts to be arbitrated. Refer to **D.5.1 QADC Module Configuration Register** for more information.

#### 8.7 Test Register

The QADC test register (QADCTEST) is used only during factory testing of the MCU.

#### 8.8 General-Purpose I/O Port Operation

QADC port pins, when used as general-purpose input, are conditioned by a synchronizer with an enable feature. The synchronizer is not enabled until the QADC decodes an IMB bus cycle which addresses the port data register to minimize the high-current effect of mid-level signals on the inputs used for analog signals. Digital input signals must meet the input low voltage ( $V_{IL}$ ) or input high voltage ( $V_{IH}$ ) specifications in **APPENDIX A ELECTRICAL CHARACTERISTICS**. If an analog input pin does not meet the digital input pin specifications when a digital port read operation occurs, an indeterminate state is read.

During a port data register read, the actual value of the pin is reported when its corresponding bit in the data direction register defines the pin to be an input (port A only). When the data direction bit specifies the pin to be an output, the content of the port data register is read. By reading the latch which drives the output pin, software instructions that read data, modify it, and write the result, like bit manipulation instructions, work correctly.

There are two special cases to consider for digital I/O port operation. When the MUX (externally multiplexed) bit is set in QACR0, the data direction register settings are ignored for the bits corresponding to PQA[2:0], the three multiplexed address MA[2:0] output pins. The MA[2:0] pins are forced to be digital outputs, regardless of the data direction setting, and the multiplexed address outputs are driven. The data returned during a port data register read is the value of the multiplexed address latches which drive MA[2:0], regardless of the data direction setting.

Similarly, when an external trigger queue operating mode is selected, the data direction register setting for the corresponding pins, PQA3 and/or PQA4, is ignored. The port pins are forced to be digital inputs for ETRIG1 and/or ETRIG2. The data read during a port data register read is the actual value of the pin, regardless of the data direction register setting.

### 8.8.1 Port Data Register

QADC ports A and B are accessed through two 8-bit port data registers (PORTQA and PORTQB). Port A pins are referred to as PQA[7:0] when used as an 8-bit input/output port. Port A can also be used for analog inputs AN[59:52], external trigger inputs ETRIG[2:1], and external multiplexer address outputs MA[2:0].

Port B pins are referred to as PQB[7:0] when used as an 8-bit input-only digital port. Port B can also be used for non-multiplexed AN[51:48]/AN[3:0] and multiplexed ANz, ANy, ANx, ANw analog inputs.

PORTQA and PORTQB are unaffected by reset. Refer to **D.5.4 Port A/B Data Register** for register and bit descriptions.

### 8.8.2 Port Data Direction Register

The port data direction register (DDRQA) is associated with the port A digital I/O pins. These bidirectional pins have somewhat higher leakage and capacitance specifications. Refer to **APPENDIX A ELECTRICAL CHARACTERISTICS** for more information.

Any bit in this register set to one configures the corresponding pin as an output. Any bit in this register cleared to zero configures the corresponding pin as an input. Software is responsible for ensuring that DDRQA bits are not set to one on pins used for analog inputs. When a DDRQA bit is set to one and the pin is selected for analog conversion, the voltage sampled is that of the output digital driver as influenced by the load.

#### NOTE

Caution should be exercised when mixing digital and analog inputs. This should be minimized as much as possible. Input pin rise and fall times should be as large as possible to minimize AC coupling effects.

Since port B is input-only, a data direction register is not needed. Read operations on the reserved bits in DDRQA return zeros, and writes have no effect. Refer to **D.5.5 Port Data Direction Register** for register and bit descriptions.

## 8.9 External Multiplexing Operation

External multiplexers concentrate a number of analog signals onto a few inputs to the analog converter. This is helpful in applications that need to convert more analog signals than the A/D converter can normally provide. External multiplexing also puts the multiplexer closer to the signal source. This minimizes the number of analog signals that need to be shielded due to the close proximity of noisy, high speed digital signals near the MCU.

The QADC can use from one to four external multiplexers to expand the number of analog signals that may be converted. Up to 32 analog channels can be converted through external multiplexer selection. The externally multiplexed channels are automatically selected from the channel field of the conversion command word (CCW) table, the same as internally multiplexed channels.

All of the automatic queue features are available for externally and internally multiplexed channels. The software selects externally multiplexed mode by setting the MUX bit in QACR0.

**Figure 8-3** shows the maximum configuration of four external multiplexers connected to the QADC. The external multiplexers select one of eight analog inputs and connect it to one analog output, which becomes an input to the QADC. The QADC provides three multiplexed address signals (MA[2:0]), to select one of eight inputs. These outputs are connected to all four multiplexers. The analog output of each multiplexer is each connected to one of four separate QADC inputs — ANw, ANx, ANy, and ANz.



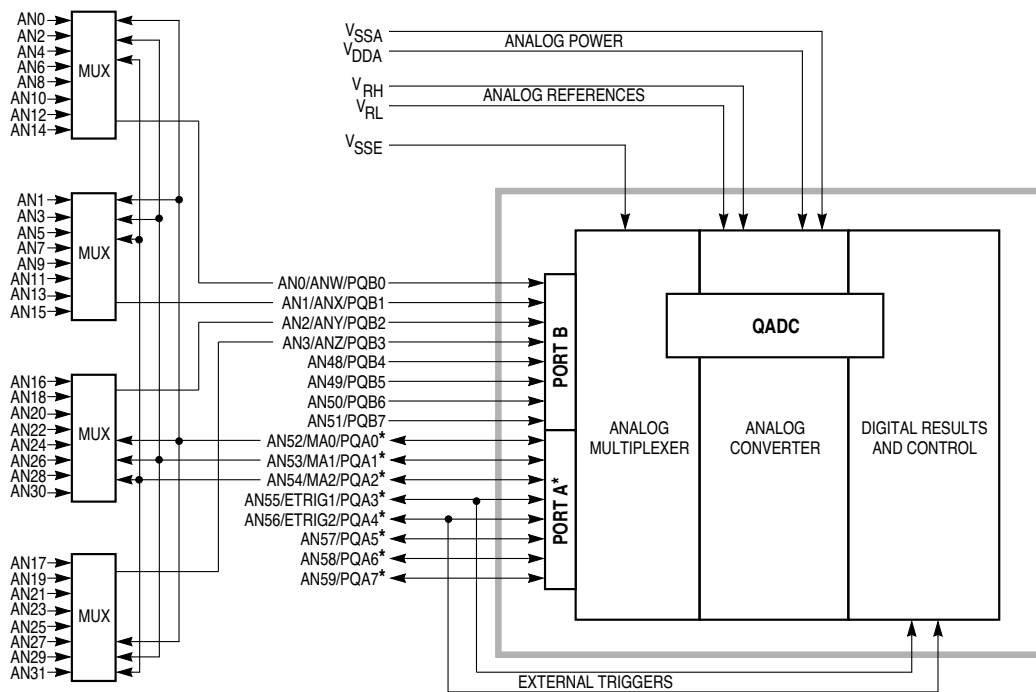

\* PORT A PINS INCORPORATE OPEN DRAIN PULL DOWN DRIVERS.

QADC EXT MUX CONN

**Figure 8-3 Example of External Multiplexing**

When the external multiplexed mode is selected, the QADC automatically creates the MA[2:0] open drain output signals from the channel number in each CCW. The QADC also converts the proper input channel (ANw, ANx, ANy, and ANz) by interpreting the CCW channel number. As a result, up to 32 externally multiplexed channels appear to the conversion queues as directly connected signals. Software simply puts the channel number of an externally multiplexed channel into a CCW.

**Figure 8-3** shows that MA[2:0] may also be analog or digital input pins. When external multiplexing is selected, none of the MA[2:0] pins can be used for analog or digital inputs. They become multiplexed address outputs.

## 8.10 Analog Input Channels

The number of available analog channels varies, depending on whether or not external multiplexing is used. A maximum of 16 analog channels are supported by the internal multiplexing circuitry of the converter. **Table 8-2** shows the total number of analog input channels supported with zero to four external multiplexers.

**Table 8-2 Analog Input Channels**

Number of Analog Input Channels Available Directly Connected + External Multiplexed = Total Channels <sup>1, 2</sup>				
No External Mux Chips	One External Mux Chip	Two External Mux Chips	Three External Mux Chips	Four External Mux Chips
16	12 + 8 = 20	11 + 16 = 27	10 + 24 = 34	9 + 32 = 41

NOTES:

1. The above assumes that the external trigger inputs are shared with two analog input pins.
2. When external multiplexing is used, three input channels become multiplexed address outputs, and for each external multiplexer chip, one input channel becomes a multiplexed analog input.

## 8.11 Analog Subsystem

The QADC analog subsystem includes a front-end analog multiplexer, a digital to analog converter (DAC) array, a comparator, and a successive approximation register (SAR).

The analog subsystem path runs from the input pins through the input multiplexing circuitry, into the DAC array, and through the analog comparator. The output of the comparator feeds into the SAR and is considered the boundary between the analog and digital subsystems of the QADC.

**Figure 8-4** shows a block diagram of the QADC analog submodule.

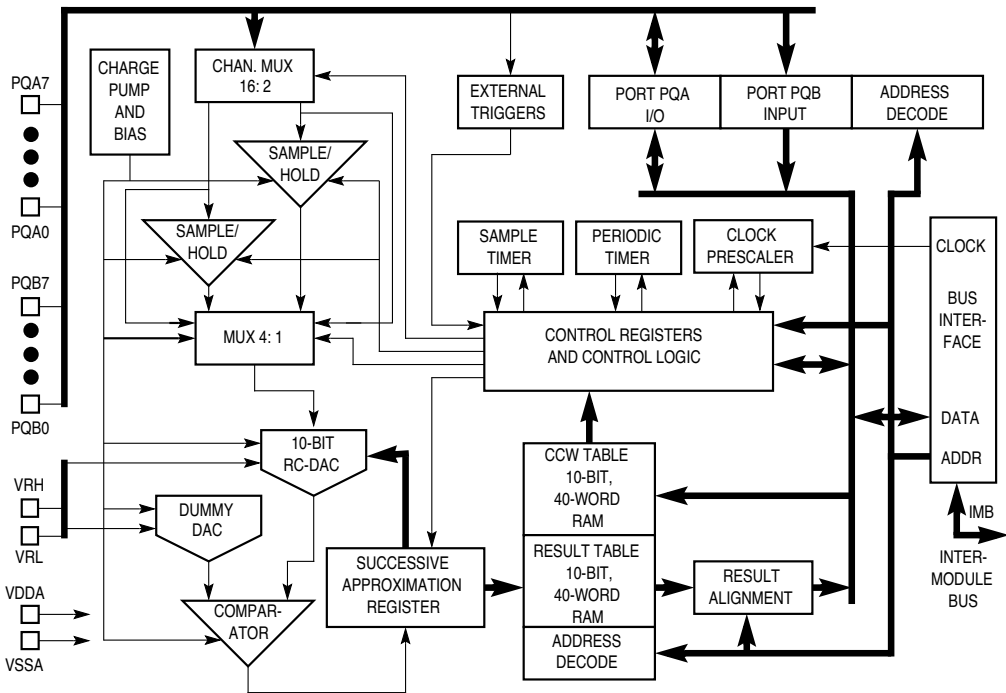

QADC DETAIL BLOCK

**Figure 8-4 QADC Module Block Diagram**

### 8.11.1 Conversion Cycle Times

Total conversion time is made up of initial sample time, transfer time, final sample time, and resolution time. Initial sample time refers to the time during which the selected input channel is connected to the sample capacitor at the input of the sample buffer amplifier. During the transfer period, the sample capacitor is disconnected from the multiplexer, and the stored voltage is buffered and transferred to the RC DAC array. During the final sampling period, the sample capacitor and amplifier are bypassed, and the multiplexer input charges the RC DAC array directly. During the resolution period, the voltage in the RC DAC array is converted to a digital value and stored in the SAR.

Initial sample time is fixed at two QCLKs and the transfer time at four QCLKs. Final sample time can be 2, 4, 8, or 16 ADC clock cycles, depending on the value of the IST field in the CCW. Resolution time is ten cycles.

Transfer and resolution require a minimum of 18 QCLK clocks (8.6  $\mu$ s with a 2.1 MHz QCLK). If the maximum final sample time period of 16 QCLKs is selected, the total conversion time is 15.2  $\mu$ s with a 2.1 MHz QCLK.

**Figure 8-5** illustrates the timing for conversions. This diagram assumes a final sampling period of two QCLKs.

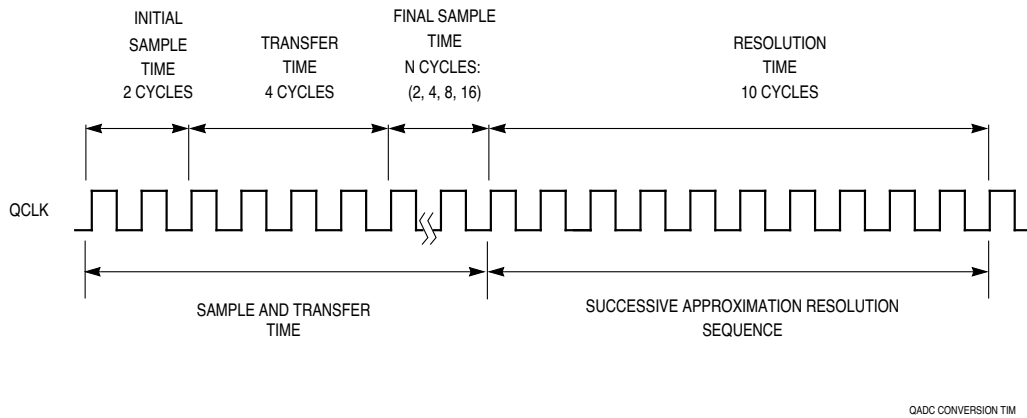

**Figure 8-5 Conversion Timing**

### 8.11.1.1 Amplifier Bypass Mode Conversion Timing

If the amplifier bypass mode is enabled for a conversion by setting the amplifier bypass (BYP) bit in the CCW, the timing changes to that shown in **Figure 8-6**. The initial sample time and the transfer time are eliminated, reducing the potential conversion time by six QCLKs. However, due to internal RC effects, a minimum final sample time of four QCLKs must be allowed. This results in a savings of four QCLKs. When using the bypass mode, the external circuit should be of low source impedance, typically less than 10 k $\Omega$ . Also, the loading effects of the external circuitry by the QADC need to be considered, since the benefits of the sample amplifier are not present.

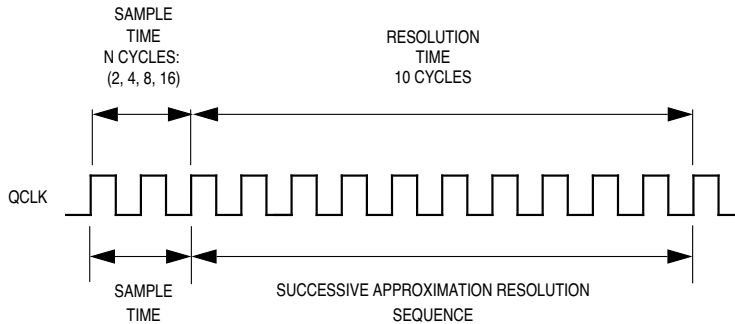

QADC BYP CONVERSION TIM

**Figure 8-6 Bypass Mode Conversion Timing**

### 8.11.2 Front-End Analog Multiplexer

The internal multiplexer selects one of the 16 analog input pins or one of three special internal reference channels for conversion. The following are the three special channels:

- $V_{RH}$  — Reference Voltage High
- $V_{RL}$  — Reference Voltage Low
- $V_{DDA}/2$  — Mid-Analog Supply Voltage

The selected input is connected to one side of the DAC capacitor array. The other side of the DAC array is connected to the comparator input. The multiplexer also includes positive and negative stress protection circuitry, which prevents other channels from affecting the current conversion when voltage levels are applied to the other channels. Refer to **APPENDIX A ELECTRICAL CHARACTERISTICS** for specific voltage level limits.

### 8.11.3 Digital to Analog Converter Array

The digital to analog converter (DAC) array consists of binary-weighted capacitors and a resistor-divider chain. The array serves two purposes:

- The array holds the sampled input voltage during conversion.
- The resistor-capacitor array provides the mechanism for the successive approximation A/D conversion.

Resolution begins with the MSB and works down to the LSB. The switching sequence is controlled by the digital logic.

#### 8.11.4 Comparator

The comparator is used during the approximation process to sense whether the digitally selected arrangement of the DAC array produces a voltage level higher or lower than the sampled input. The comparator output feeds into the SAR which accumulates the A/D conversion result sequentially, starting with the MSB.

#### 8.11.5 Successive Approximation Register

The input of the successive approximation register (SAR) is connected to the comparator output. The SAR sequentially receives the conversion value one bit at a time, starting with the MSB. After accumulating the ten bits of the conversion result, the SAR data is transferred to the appropriate result location, where it may be read by user software.

### 8.12 Digital Control Subsystem

The digital control subsystem includes conversion sequencing logic, channel selection logic, the clock and periodic/interval timer, control and status registers, the conversion command word table RAM, and the result word table RAM.

The central element for control of the QADC conversions is the 40-entry conversion command word (CCW) table. Each CCW specifies the conversion of one input channel. Depending on the application, one or two queues can be established in the CCW table. A queue is a scan sequence of one or more input channels. By using a pause mechanism, subqueues can be created in the two queues. Each queue can be operated using several different scan modes. The scan modes for queue 1 and queue 2 are programmed in QACR1 and QACR2. Once a queue has been started by a trigger event (any of the ways to cause the QADC to begin executing the CCWs in a queue or subqueue), the QADC performs a sequence of conversions and places the results in the result word table.

#### 8.12.1 Queue Priority

Queue 1 has execution priority over queue 2 execution. **Table 8-3** shows the conditions under which queue 1 asserts its priority:

**Table 8-3 Queue 1 Priority Assertion**

Queue State	Result
Inactive	A trigger event for queue 1 or queue 2 causes the corresponding queue execution to begin.
Queue 1 active/trigger event occurs for queue 2	Queue 2 cannot begin execution until queue 1 reaches completion or the paused state. The status register records the trigger event by reporting the queue 2 status as trigger pending. Additional trigger events for queue 2, which occur before execution can begin, are recorded as trigger overruns.
Queue 2 active/trigger event occurs for queue 1	The current queue 2 conversion is aborted. The status register reports the queue 2 status as suspended. Any trigger events occurring for queue 2 while queue 2 is suspended are recorded as trigger overruns. Once queue 1 reaches the completion or the paused state, queue 2 begins executing again. The programming of the resume bit in QACR2 determines which CCW is executed in queue 2.
Simultaneous trigger events occur for queue 1 and queue 2	Queue 1 begins execution and the queue 2 status is changed to trigger pending.
Subqueues paused	The pause feature can be used to divide queue 1 and/or queue 2 into multiple subqueues. A subqueue is defined by setting the pause bit in the last CCW of the subqueue.

**Figure 8-7** shows the CCW format and an example of using pause to create subqueues. Queue 1 is shown with four CCWs in each subqueue and queue 2 has two CCWs in each subqueue.

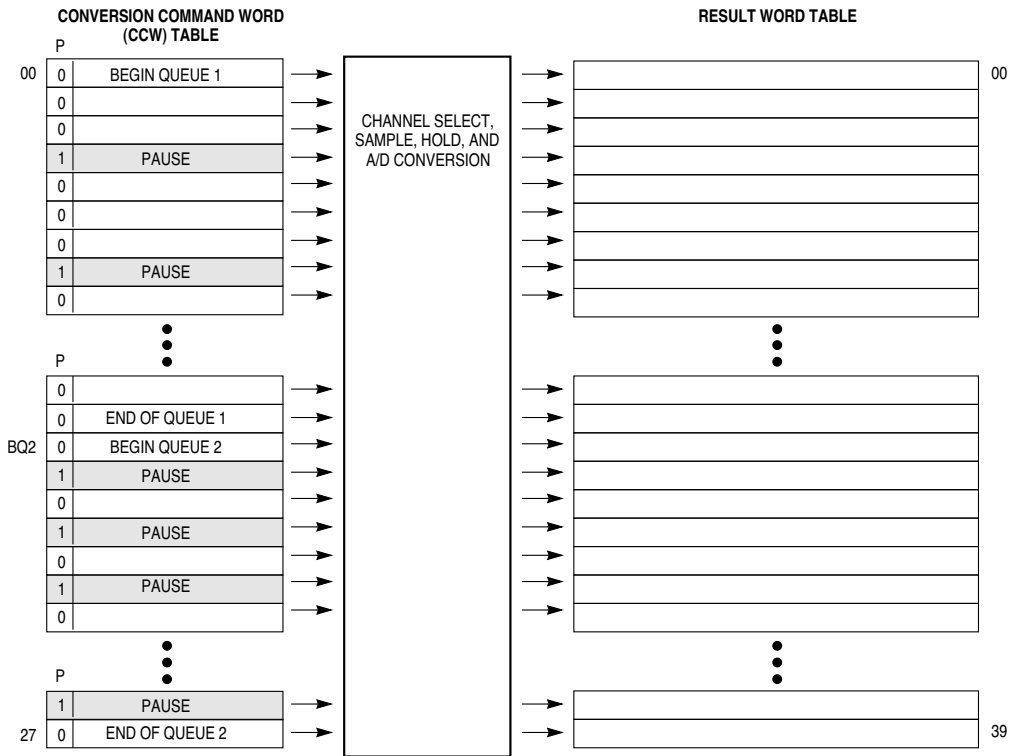

QADC COP

**Figure 8-7 QADC Queue Operation with Pause**

The queue operating mode selected for queue 1 determines what type of trigger event causes the execution of each of the subqueues within queue 1. Similarly, the queue operating mode for queue 2 determines the type of trigger event required to execute each of the subqueues within queue 2.

The choice of single-scan or continuous-scan applies to the full queue, and is not applied to each subqueue. Once a subqueue is initiated, each CCW is executed sequentially until the last CCW in the subqueue is executed and the pause state is entered. Execution can only continue with the next CCW, which is the beginning of the next subqueue. A subqueue cannot be executed a second time before the overall queue execution has been completed.

Trigger events which occur during the execution of a subqueue are ignored, except that the trigger overrun flag is set. When continuous-scan mode is selected, a trigger event occurring after the completion of the last subqueue (after the queue completion flag is set), causes execution to continue with the first subqueue, starting with the first CCW in the queue.



When the QADC encounters a CCW with the pause bit set, the queue enters the paused state after completing the conversion specified in the CCW with the pause bit. The pause flag is set and a pause software interrupt may optionally be issued. The status of the queue is shown to be paused, indicating completion of a subqueue. The QADC then waits for another trigger event to again begin execution of the next subqueue.

### 8.12.2 Queue Boundary Conditions

A queue boundary condition occurs when one or more of the queue operating parameters is configured in a way that will inhibit queue execution. One such boundary condition is when the first CCW in a queue specified channel 63, the end-of-queue (EOQ) code. In this case, the queue becomes active and the first CCW is read. The EOQ code is recognized, the completion flag is set, and the queue becomes idle. A conversion is not performed.

A similar situation occurs when BQ2 (beginning of queue 2 pointer) is set beyond the end of the CCW table (between \$28 and \$3F) and a trigger event occurs for queue 2. The EOQ condition is recognized immediately, the completion flag is set, and the queue becomes idle. A conversion is not performed.

The QADC behaves the same way when BQ2 is set to CCW0 and a trigger event occurs for queue 1. After reading CCW0, the EOQ condition is recognized, the completion flag is set, and the queue becomes idle. A conversion is not performed.

Multiple EOQ conditions may be recognized simultaneously, but the QADC will not behave differently. One example is when BQ2 is set to CCW0, CCW0 contains the EOQ code, and a trigger event occurs for queue 1. The QADC will read CCW0 and recognize the queue 1 trigger event, detecting both as EOQ conditions. The completion flag will be set and queue 1 will become idle.

Boundary conditions also exist for combinations of pause and end-of-queue. One case is when a pause bit is in one CCW and an end-of-queue condition is in the next CCW. The conversion specified by the CCW with the pause bit set completes normally. The pause flag is set. However, since the end-of-queue condition is recognized, the completion flag is also set and the queue status becomes idle, not paused. Examples of this situation include:

- The pause bit is set in CCW5 and the channel 63 (EOQ) code is in CCW6.
- The pause bit is set in CCW27.
- During queue 1 operation, the pause bit is set in CCW14 and BQ2 points to CCW15.

Another pause and end-of-queue boundary condition occurs when the pause and an end-of-queue condition occur in the same CCW. Both the pause and end-of-queue conditions are recognized simultaneously. The end-of-queue condition has precedence so a conversion is not performed for the CCW and the pause flag is not set. The QADC sets the completion flag and the queue status becomes idle. Examples of this situation are:

- The pause bit is set in CCW0A and EOQ is programmed into CCW0A.
- During queue 1 operation, the pause bit is set in CCW20, which is also BQ2.

### 8.12.3 Scan Modes

The QADC queuing mechanism provides several methods for automatically scanning input channels. In single-scan mode, a single pass through a sequence of conversions defined by a queue is performed. In continuous-scan mode, multiple passes through a sequence of conversions defined by a queue are executed. The following paragraphs describe the disabled/reserved, single-scan, and continuous-scan operations.

#### 8.12.3.1 Disabled Mode and Reserved Mode

When the disabled mode or a reserved mode is selected, the queue is not active.

#### NOTE

Do not use a reserved mode. Unspecified operations may result.

Trigger events cannot initiate queue execution. When both queue 1 and queue 2 are disabled, no wait states will be inserted by the QADC for accesses to the CCW and result word tables. When both queues are disabled, it is safe to change the QADC clock prescaler values.

#### 8.12.3.2 Single-Scan Modes

When application software requires execution of a single pass through a sequence of conversions defined by a queue, a single-scan queue operating mode is selected.

In all single-scan queue operating modes, software must enable a queue for execution by writing the single-scan enable bit to one in the queue's control register. The single-scan enable bits, SSE1 and SSE2, are provided for queue 1 and queue 2, respectively.

Until the single-scan enable bit is set, any trigger events for that queue are ignored. The single-scan enable bit may be set to one during the write cycle that selects the single-scan queue operating mode. The single-scan enable bit can be written as a one or a zero but is always read as a zero.

After the single-scan enable bit is set, a trigger event causes the QADC to begin execution with the first CCW in the queue. The single-scan enable bit remains set until the queue scan is complete; the QADC then clears the single-scan enable bit to zero. If the single-scan enable bit is written to one or zero before the queue scan is complete, the queue is not affected. However, if software changes the queue operating mode, the new queue operating mode and the value of the single-scan enable bit are recognized immediately. The current conversion is aborted and the new queue operating mode takes effect.

By properly programming the MQ1 field in QACR1 or the MQ2 field in QACR2, the following modes can be selected for queue 1 and/or 2:

- Software initiated single-scan mode
  - Software can initiate the execution of a scan sequence for queue 1 or 2 by selecting this mode, and setting the single-scan enable bit in QACR1 or QACR2. A trigger event is generated internally and the QADC immediately begins execution of the first CCW in the queue. If a pause is encountered, queue execution ceases momentarily while another trigger event is generated internally, and then execution continues. While the time to internally generate and act on a trigger event is very short, software can momentarily read the status conditions, indicating that the queue is paused.
  - The QADC automatically performs the conversions in the queue until an end-of-queue condition is encountered. The queue remains idle until software again sets the single-scan enable bit. The trigger overrun flag is never set while in this mode.
- External trigger rising or falling edge single-scan mode
  - This mode is a variation of the external trigger continuous-scan mode. It is available for both queue 1 and queue 2. Software programs the external trigger to be either a rising or a falling edge. Software must also set the single-scan enable bit for the queue in order for the scan to take place. The first external trigger edge causes the queue to be executed one time. Each CCW is read and the indicated conversions are performed until an end-of-queue condition is encountered. After the queue scan is complete, the QADC clears the single-scan enable bit. Software may set the single-scan enable bit again to allow another scan of the queue to be initiated by the next external trigger edge.
- Interval timer single-scan mode
  - In addition to the above modes, queue 2 can also be programmed for the interval timer single-scan mode. The queue operating mode for queue 2 is selected by the MQ2 field in QACR2.
  - When this mode is selected and software sets the single-scan enable bit in QACR2, the periodic/interval timer begins counting. The timer interval can range from  $2^7$  to  $2^{17}$  QCLK cycles in binary multiples. When the time interval expires, a trigger event is generated internally to start the queue. The timer is reloaded and begins counting again. Meanwhile, the QADC begins execution with the first CCW in queue 2.
  - The QADC automatically performs the conversions in the queue until a pause or an end-of-queue condition is encountered. When a pause is encountered, queue execution stops until the timer interval expires again; queue execution then continues. When an end of queue condition is encountered, the timer is held in reset and the single-scan enable bit is cleared.
  - Software may set the single-scan enable bit again, allowing another scan of the queue to be initiated by the interval timer. The interval timer generates a trigger event whenever the time interval elapses. The trigger event may cause queue execution to continue following a pause, or may be considered a trigger overrun if the queue is currently executing.

### 8.12.3.3 Continuous-Scan Modes

When application software requires execution of multiple passes through a sequence of conversions defined by a queue, a continuous-scan queue operating mode is selected.

When a queue is programmed for a continuous-scan mode, the single-scan enable bit in the queue control register does not have any meaning or effect. As soon as the queue operating mode is programmed, the selected trigger event can initiate queue execution.

In the case of the software initiated continuous-scan mode, the trigger event is generated internally and queue execution begins immediately. In the other continuous-scan queue operating modes, the selected trigger event must occur before the queue can start. A trigger overrun is recorded if a trigger event occurs during queue execution in the external trigger continuous-scan mode and the periodic timer continuous-scan mode. When a pause is encountered during a scan, another trigger event is required for queue execution to continue. Software involvement is not required for queue execution to continue from the paused state.

After queue execution is complete, the queue status is shown as idle. Since the continuous-scan queue operating modes allow an entire queue to be scanned multiple times, software involvement is not required for queue execution to continue from the idle state. The next trigger event causes queue execution to begin again, starting with the first CCW in the queue.

#### NOTE

It may not be possible to guarantee coherent samples when using the continuous-scan queue operating modes since the relationship between any two conversions may be variable due to programmable trigger events and queue priorities.

By programming the MQ1 field in QACR1 or the MQ2 field in QACR2, the following modes can be selected for queue 1 and/or 2:

- Software initiated continuous-scan mode
  - When this mode is programmed, the trigger event is generated automatically by the QADC, and queue execution begins immediately. If a pause is encountered, queue execution ceases for two QCLKs, while another trigger event is generated internally; execution then continues. When the end-of-queue is reached, another internal trigger event is generated, and queue execution begins again from the beginning of the queue.
  - While the time to internally generate and act on a trigger event is very short, software can momentarily read the status conditions, indicating that the queue is paused or idle. The trigger overrun flag is never set while in the software initiated continuous-scan mode.

- This mode keeps the result registers updated more frequently than any of the other queue operating modes. Software can always read the result table to get the latest converted value for each channel. The channels scanned are kept up to date by the QADC without software involvement.
- This mode may be chosen for either queue, but is normally used only with queue 2. When the software initiated continuous-scan mode is chosen for queue 1, that queue operates continuously and queue 2, being lower in priority, never gets executed. The short interval of time between a queue 1 pause and the internally generated trigger event, or between a queue 1 completion and the subsequent trigger event is not sufficient to allow queue 2 execution to begin.
- External trigger rising or falling edge continuous-scan mode
  - The QADC provides external trigger pins for both queues. When this mode is selected, a transition on the associated external trigger pin initiates queue execution. The external trigger is programmable, so that queue execution can begin on either a rising or a falling edge. Each CCW is read and the indicated conversions are performed until an end-of-queue condition is encountered. When the next external trigger edge is detected, queue execution begins again automatically. Software initialization is not needed between trigger events.
- Periodic timer continuous-scan mode
  - In addition to the previous modes, queue 2 can also be programmed for the periodic timer continuous-scan mode, where a scan is initiated at a selectable time interval using the on-chip periodic/interval timer. The queue operating mode for queue 2 is selected by the MQ2 field in QACR2.
  - The QADC includes a dedicated periodic/interval timer for initiating a scan sequence for queue 2 only. A programmable timer interval can be selected ranging from  $2^7$  to  $2^{17}$  times the QCLK period in binary multiples.
  - When this mode is selected, the timer begins counting. After the programmed interval elapses, the timer generated trigger event starts the queue. The timer is then reloaded and begins counting again. Meanwhile, the QADC automatically performs the conversions in the queue until an end-of-queue condition or a pause is encountered. When a pause is encountered, the QADC waits for the periodic interval to expire again, then continues with the queue. When an end-of-queue is encountered, the next trigger event causes queue execution to begin again with the first CCW in queue 2.
  - The periodic timer generates a trigger event whenever the time interval elapses. The trigger event may cause queue execution to continue following a pause or queue completion, or may be considered a trigger overrun. As with all continuous-scan queue operating modes, software action is not needed between trigger events.
  - If the queue completion interrupt is enabled when using this mode, software can read the analog results that have just been collected. Software can use this interrupt to obtain non-analog inputs as well, as part of a periodic look at all inputs.

### 8.12.4 QADC Clock (QCLK) Generation

**Figure 8-8** is a block diagram of the clock subsystem. QCLK provides the timing for the A/D converter state machine which controls the timing of conversions. QCLK is also the input to a 17-stage binary divider which implements the periodic/interval timer. To obtain the specified analog conversion accuracy, the QCLK frequency ( $f_{QCLK}$ ) must be within the tolerance specified in **Table A-13**.

Before using the QADC, software must initialize the prescaler with values that put QCLK within a specified range. Though most applications initialize the prescaler once and do not change it, write operations to the prescaler fields are permitted.

#### CAUTION

A change in the prescaler value while a conversion is in progress is likely to corrupt the conversion result. Therefore, any prescaler write operation should be done only when both queues are disabled.

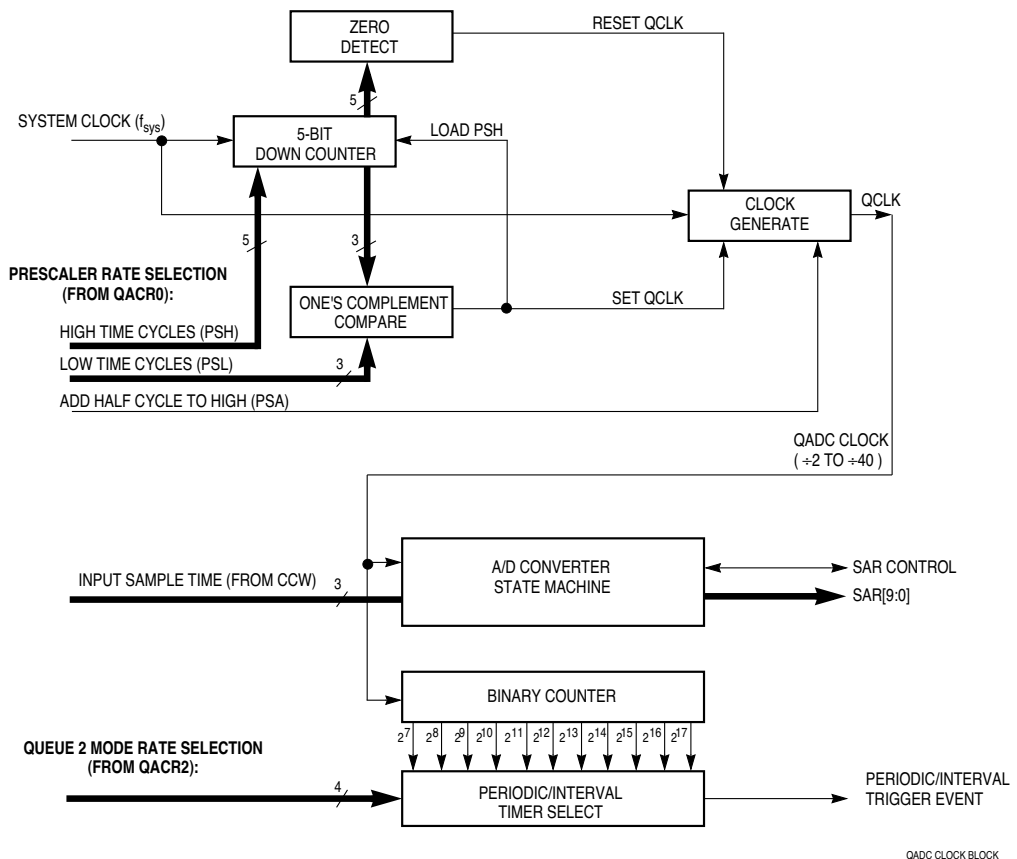

**Figure 8-8 QADC Clock Subsystem Functions**

To accommodate wide variations of the main MCU clock frequency  $f_{sys}$ , QCLK is generated by a programmable prescaler which divides the MCU system clock to a frequency within the specified QCLK tolerance range. The prescaler also allows the duty cycle of the QCLK waveform to be programmable.

The basic high phase of the QCLK waveform is selected with the PSH (prescaler clock high time) field in QACR0, and the basic low phase of QCLK with the PSL (prescaler clock low time) field. The duty cycle of QCLK can be further modified with the PSA (prescaler add a clock tick) bit in QACR0. The combination of the PSH and PSL parameters establishes the frequency of QCLK.

**Figure 8-8** shows that the prescaler is essentially a variable pulse width signal generator. A 5-bit down counter, clocked at the system clock rate, is used to create both the high phase and the low phase of the QCLK signal. At the beginning of the high phase, the 5-bit counter is loaded with the 5-bit PSH value. When the zero detector finds that the high phase is finished, QCLK is reset. A 3-bit comparator looks for a one's complement match with the 3-bit PSL value, which is the end of the low phase of QCLK. The PSA bit allows the QCLK high-to-low transition to be delayed by a half cycle of the input clock.

The following sequence summarizes the process of determining what values are to be put into the prescaler fields in QACR0:

1. Choose the system clock frequency  $f_{sys}$ .
2. Choose first-try values for PSH, PSL, and PSA, then skip to step 4.
3. Choose different values for PSH, PSL, and PSA.
4. If the QCLK high time is less than  $t_{PSH}$  (QADC clock duty cycle – Minimum high phase time), return to step 3. Refer to **Table A-13** for more information on  $t_{PSH}$ . QCLK high time is determined by the following equation:

$$\text{QCLK high time (in ns)} = \frac{1000 (1 + \text{PSH} + 0.5 \text{ PSA})}{f_{sys}(\text{in MHz})}$$

where PSH = 0 to 31 and PSA = 0 or 1.

5. If QCLK low time is less than  $t_{PSL}$  (QADC clock duty cycle – Minimum low phase time), return to step 3. Refer to **Table A-13** for more information on  $t_{PSL}$ . QCLK low time is determined by the following equation:

$$\text{QCLK low time (in ns)} = \frac{1000 (1 + \text{PSL} - 0.5 \text{ PSA})}{f_{sys}(\text{in MHz})}$$

where PSL = 0 to 7 and PSA = 0 or 1.

- Calculate the QCLK frequency ( $f_{\text{QCLK}}$ ).

$$f_{\text{QCLK}} \text{ (in MHz)} = \frac{1000}{\text{QCLK high time (in ns)} + \text{QCLK low time (in ns)}}$$

- Choose the number of input sample cycles (2, 4, 8, or 16) for a typical input channel.
- If the calculated conversion times are not sufficient, return to step 3. Conversion time is determined by the following equation:

$$\text{Conversion time (in } \mu\text{s)} = \frac{16 + \text{Number of input sample cycles}}{f_{\text{QCLK}} \text{ (in MHz)}}$$

- Code the selected PSH, PSL, and PSA values into the prescaler fields of QACR0.

**Figure 8-9** and **Table 8-4** show examples of QCLK programmability. The examples include conversion times based on the following assumptions:

- $f_{\text{sys}} = 20.97 \text{ MHz}$ .
- Input sample time is as fast as possible ( $\text{IST}[1:0] = \%00$ , 2 QCLK cycles).

**Figure 8-9** and **Table 8-4** also show the conversion time calculated for a single conversion in a queue. For other MCU system clock frequencies and other input sample times, the same calculations can be made.

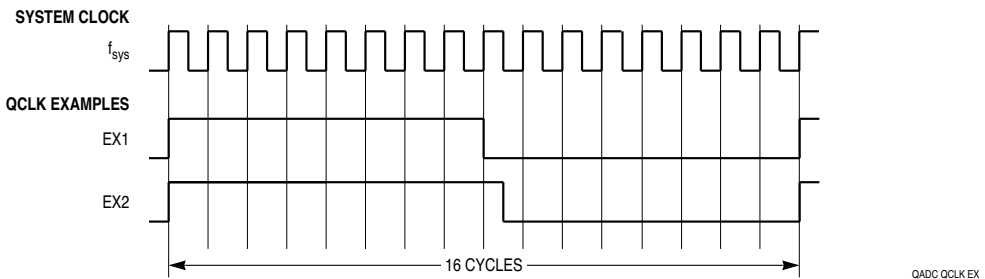

**Figure 8-9 QADC Clock Programmability Examples**



**Table 8-4 QADC Clock Programmability**

Control Register 0 Information				$f_{\text{SYS}} = 20.97$ Input Sample Time (IST) = %00	
Example Number	PSH[4:0]	PSA	PSL[2:0]	QCLK (MHz)	Conversion Time ( $\mu\text{s}$ )
1	7	0	7	1.0	18.0
2	7	1	7	1.0	18.0

The MCU system clock frequency is the basis of QADC timing. The QADC requires that the system clock frequency be at least twice the QCLK frequency. Refer to **Table A-13** for information on the minimum and maximum allowable QCLK frequencies.

Example 1 in **Figure 8-9** shows that when PSH = 3, the QCLK remains high for four system clock cycles. It also shows that when PSL = 3, the QCLK remains low for four system clock cycles.

In order to tune QCLK for the fastest possible conversion time for any given system clock frequency, the QADC permits one more programmable control of the QCLK high and low time. The PSA bit in QACR0 allows the QCLK high phase to be stretched for a half cycle of the system clock, and correspondingly, the QCLK low phase is shortened by a half cycle of the system clock.

Example 2 in **Figure 8-9** is the same as Example 1, except that the PSA bit is set. The QCLK high phase has 4.5 system clock cycles; the QCLK low phase has 3.5 system clock cycles.

### 8.12.5 Periodic/Interval Timer

The QADC periodic/interval timer can be used to generate trigger events at programmable intervals to initiate scans of queue 2. The periodic/interval timer is held in reset under the following conditions:

- Queue 2 is programmed to any queue operating mode which does not use the periodic/interval timer
- Interval timer single-scan mode is selected, but the single-scan enable bit is cleared to zero
- IMB system reset or the master reset is asserted
- The QADC is placed in low-power stop mode with the STOP bit
- The IMB FREEZE line is asserted and the QADC FRZ bit is set to one

Two other conditions which cause a pulsed reset of the timer are:

- Rollover of the timer counter
- A queue operating mode change from one periodic/interval timer mode to another periodic/interval timer mode

During the low-power stop mode, the periodic/interval timer is held in reset. Since low-power stop mode initializes QACR2 to zero, a valid periodic or interval timer mode must be written to QACR2 when exiting low-power stop mode to release the timer from reset.

If the QADC FRZ bit is set to one and the IMB FREEZE line is asserted while a periodic or interval timer mode is selected, the timer is reset after the current conversion completes. When a periodic or interval timer mode has been enabled (the timer is counting), but a trigger event has not been issued, freeze mode takes effect immediately, and the timer is held in reset. When the IMB FREEZE line is negated, the timer starts counting from zero.

### **8.12.6 Control and Status Registers**

The following paragraphs describe the control and status registers. The QADC has three control registers and one status register. All of the implemented control register fields can be read or written. Reserved locations read zero and writes have no effect. The control registers are typically written once when software initializes the QADC and are not changed afterwards. Refer to **D.5.6 QADC Control Registers** for register and bit descriptions.

#### **8.12.6.1 Control Register 0 (QACR0)**

Control register QACR0 establishes the QCLK with prescaler parameter fields and defines whether external multiplexing is enabled.

#### **8.12.6.2 Control Register 1 (QACR1)**

Control register QACR1 is the mode control register for queue 1. Applications software defines the operating mode for the queue, and may enable a completion and/or pause interrupt. The SSE1 bit may be written to one or zero but always reads zero.

#### **8.12.6.3 Control Register 2 (QACR2)**

Control register QACR2 is the mode control register for queue 2. Applications software defines the operating mode for the queue, and may enable a completion and/or pause interrupt. The SSE2 bit may be written to one or zero but always reads zero.

#### **8.12.6.4 Status Register (QASR)**

The status register QASR contains information about the state of each queue and the current A/D conversion. Except for the four flag bits (CF1, PF1, CF2, and PF2) and the two trigger overrun bits (TOR1 and TOR2), all of the status register fields contain read-only data. The four flag bits and the two trigger overrun bits are cleared by writing a zero to the bit after the bit was previously read as a one.

### **8.12.7 Conversion Command Word Table**

The CCW table is a 40-word long, 10-bit wide RAM, which can be programmed to request conversions of one or more analog input channels. The entries in the CCW table are 10-bit conversion command words. The CCW table is written by software and is not modified by the QADC. Each CCW requests the conversion of an analog channel to a digital result. The CCW specifies the analog channel number, the input sample time, and whether the queue is to pause after the current CCW. Refer to **D.5.8 Conversion Command Word Table** for register and bit descriptions.

The ten implemented bits of the CCW word can be read and written. Unimplemented bits are read as zeros, and write operations have no effect. Each location in the CCW table corresponds to a location in the result word table. When a conversion is completed for a CCW entry, the 10-bit result is written in the corresponding result word entry.

The beginning of queue 1 is the first location in the CCW table. The first location of queue 2 is specified by the beginning of queue 2 pointer BQ2 in QACR2. To dedicate the entire CCW table to queue 1, queue 2 is disabled, and BQ2 is programmed to any value greater than 39. To dedicate the entire CCW table to queue 2, queue 1 is disabled, and BQ2 is specified as the first location in the CCW table.

**Figure 8-10** illustrates the operation of the queue structure.

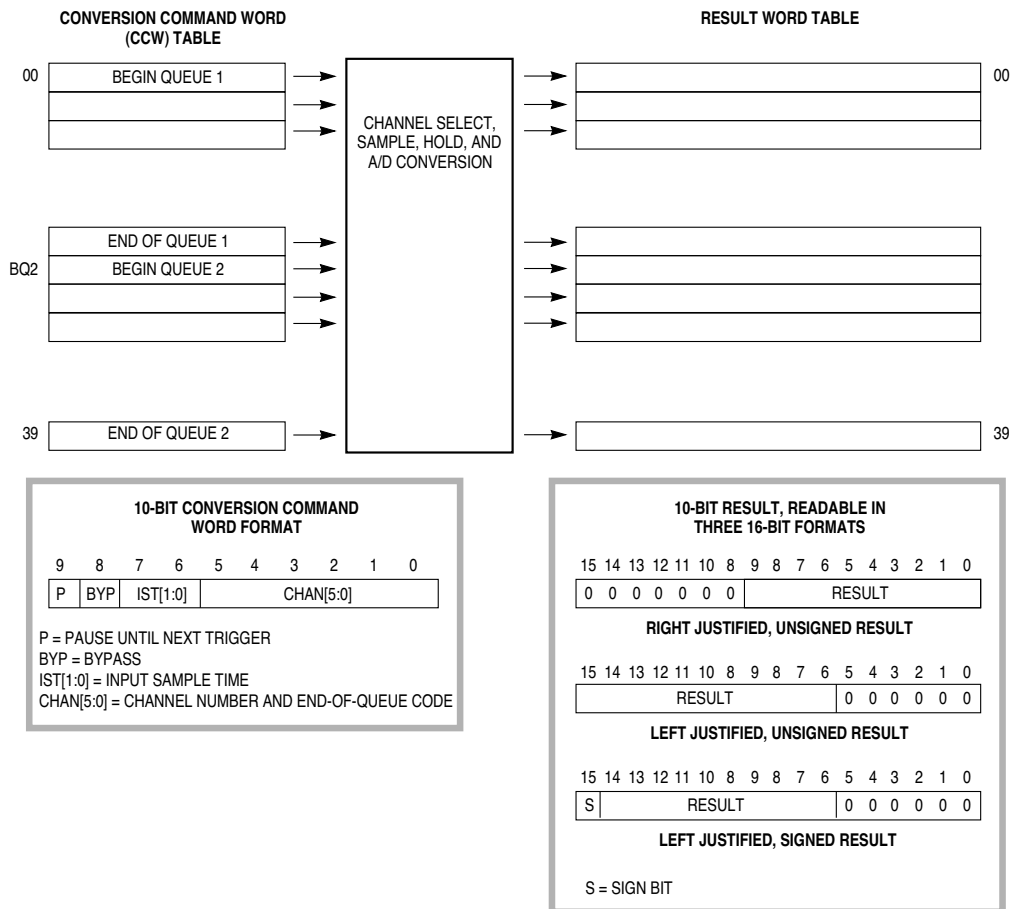

QADC 00

**Figure 8-10** QADC Conversion Queue Operation

To prepare the QADC for a scan sequence, the desired channel conversions are written to the CCW table. Software establishes the criteria for initiating the queue execution by programming queue operating mode. The queue operating mode determines what type of trigger event initiates queue execution.

A scan sequence may be initiated by the following trigger events:

- A software command
- Expiration of the periodic/interval timer
- An external trigger signal

Software also specifies whether the QADC is to perform a single pass through the queue or is to scan continuously. When a single-scan mode is selected, queue execution begins when software sets the single-scan enable bit. When a continuous-scan mode is selected, the queue remains active in the selected queue operating mode after the QADC completes each queue scan sequence.

During queue execution, the QADC reads each CCW from the active queue and executes conversions in four stages:

1. Initial sample
2. Transfer
3. Final sample
4. Resolution

During initial sample, the selected input channel is connected to the sample capacitor at the input of the sample buffer amplifier.

During the transfer period, the sample capacitor is disconnected from the multiplexer, and the stored voltage is buffered and transferred to the RC DAC array.

During the final sample period, the sample capacitor and amplifier are bypassed, and the multiplexer input charges the RC DAC array directly. Each CCW specifies a final input sample time of 2, 4, 8, or 16 QCLK cycles. When an analog-to-digital conversion is complete, the result is written to the corresponding location in the result word table. The QADC continues to sequentially execute each CCW in the queue until the end of the queue is detected or a pause bit is found in a CCW.

When the pause bit is set in the current CCW, the QADC stops execution of the queue until a new trigger event occurs. The pause status flag bit is set, which may generate an interrupt request to notify software that the queue has reached the pause state. When the next trigger event occurs, the paused state ends, and the QADC continues to execute each CCW in the queue until another pause is encountered or the end of the queue is detected.

An end-of-queue condition is indicated as follows:

- The CCW channel field is programmed with 63 (\$3F) to specify the end of the queue.
- The end of queue 1 is implied by the beginning of queue 2, which is specified in the BQ2 field in QACR2.
- The physical end of the queue RAM space defines the end of either queue.

When any of the end-of-queue conditions is recognized, a queue completion flag is set, and if enabled, an interrupt request is generated. The following situations prematurely terminate queue execution:

- Since queue 1 is higher in priority than queue 2, when a trigger event occurs on queue 1 during queue 2 execution, the execution of queue 2 is suspended by aborting execution of the CCW in progress, and queue 1 execution begins. When queue 1 execution is complete, queue 2 conversions restart with the first CCW entry in queue 2 or the first CCW of the queue 2 subqueue being executed when queue 2 was suspended. Alternately, conversions can restart with the aborted queue 2 CCW entry. The resume RES bit in QACR2 allows software to select where queue 2 begins after suspension. By choosing to re-execute all of the suspended queue 2 and subqueue CCWs, all of the samples are guaranteed to have been taken during the same scan pass. However, a high trigger event rate for queue 1 can prohibit the completion of queue 2. If this occurs, execution of queue 2 may begin with the aborted CCW entry.
- When a queue is disabled, any conversion taking place for that queue is aborted. Putting a queue into disabled mode does not power down the converter.
- When the operating mode of a queue is changed to another valid mode, any conversion taking place for that queue is aborted. The queue operating restarts at the beginning of the queue, once an appropriate trigger event occurs.
- When placed in low-power stop mode, the QADC aborts any conversion in progress.
- When the FRZ bit in the QADCMCR is set and the IMB FREEZE line is asserted, the QADC freezes at the end of the current conversion. When FREEZE is negated, the QADC resumes queue execution beginning with the next CCW entry.

### 8.12.8 Result Word Table

The result word table is a 40-word long, 10-bit wide RAM. The QADC writes a result word after completing an analog conversion specified by the corresponding CCW. The result word table can be read or written, but in normal operation, software reads the result word table to obtain analog conversions from the QADC. Unimplemented bits are read as zeros, and write operations have no effect. Refer to **D.5.9 Result Word Table** for register descriptions.

While there is only one result word table, the data can be accessed in three different alignment formats:

1. Right justified, with zeros in the higher order unused bits.
2. Left justified, with the most significant bit inverted to form a sign bit, and zeros in the unused lower order bits.
3. Left justified, with zeros in the unused lower order bits.

The left justified, signed format corresponds to a half-scale, offset binary, two's complement data format. The data is routed onto the IMB according to the selected format. The address used to access the table determines the data alignment format. All write operations to the result word table are right justified.

## 8.13 Interrupts

The QADC supports both polled and interrupt driven operation. Status bits in QASR reflect the operating condition of each queue and can optionally generate interrupts when enabled by the appropriate bits in QACR1 and/or QACR2.

### 8.13.1 Interrupt Sources

The QADC has four interrupt service sources, each of which is separately enabled. Each time the result is written for the last CCW in a queue, the completion flag for the corresponding queue is set, and when enabled, an interrupt request is generated. In the same way, each time the result is written for a CCW with the pause bit set, the queue pause flag is set, and when enabled, an interrupt request is generated.

**Table 8-5** displays the status flag and interrupt enable bits which correspond to queue 1 and queue 2 activity.

**Table 8-5 QADC Status Flags and Interrupt Sources**

Queue	Queue Activity	Status Flag	Interrupt Enable Bit
Queue 1	Result written for the last CCW in queue 1	CF1	CIE1
	Result written for a CCW with pause bit set in queue 1	PF1	PIE1
Queue 2	Result written for the last CCW in queue 2	CF2	CIE2
	Result written for a CCW with pause bit set in queue 2	PF2	PIE2

Both polled and interrupt-driven QADC operations require that status flags must be cleared after an event occurs. Flags are cleared by first reading QASR with the appropriate flag bits set to one, then writing zeros to the flags that are to be cleared. A flag can be cleared only if the flag was a logic one at the time the register was read by the CPU. If a new event occurs between the time that the register is read and the time that it is written, the associated flag is not cleared.

### 8.13.2 Interrupt Register

The QADC interrupt register QADCINT specifies the priority level of QADC interrupt requests and the upper six bits of the vector number provided during an interrupt acknowledge cycle.

The values contained in the IRLQ1 and IRLQ2 fields in QADCINT determine the priority of QADC interrupt service requests. A value of %000 in either field disables the interrupts associated with that field. The interrupt levels for queue 1 and queue 2 may be different.

The IVB[7:2] bits specify the upper six bits of each QADC interrupt vector number. IVB[1:0] have fixed assignments for each of the four QADC interrupt sources. Refer to **8.13.3 Interrupt Vectors** for more information.

### 8.13.3 Interrupt Vectors

When the QADC is the only module with an interrupt request pending at the level being acknowledged, or when the QADC IARB value is higher than that of other modules with requests pending at the acknowledged IRQ level, the QADC responds to the interrupt acknowledge cycle with an 8-bit interrupt vector number. The CPU32 uses the vector number to calculate a displacement into the exception vector table, then uses the vector at that location to jump to an interrupt service routine.

The interrupt vector base field IVB[7:2] specifies the six high-order bits of the 8-bit interrupt vector number, and the QADC provides two low-order bits which correspond to one of the four QADC interrupt sources.

**Figure 8-11** shows the format of the interrupt vector, and lists the binary coding of the two low-order bits for the four QADC interrupt sources.

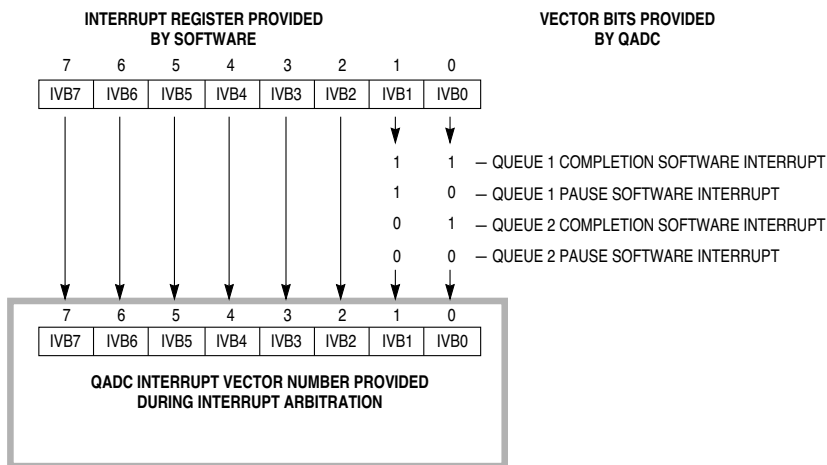

**Figure 8-11 QADC Interrupt Vector Format**

The IVB field has a reset value of \$0F, which corresponds to the uninitialized interrupt exception vector.

### 8.13.4 Initializing the QADC for Interrupt Driven Operation

The following steps are required to ensure proper operation of QADC interrupts:

1. Assign the QADC a unique non-zero IARB value. The IARB field is located in QADCMCR. The lowest priority IARB value is %0001, and the highest priority IARB value is %1111.
2. Set the interrupt request levels for queue 1 and queue 2 in the IRLQ1 and IRLQ2 fields in QADCINT. Level %001 is the lowest priority interrupt request, and level %111 is the highest priority request.
3. Set the six high-order bits of the eight-bit IVB field in QADCINT. The QADC provides the two low-order vector bits to identify one of four QADC interrupt requests. The vector number for each QADC interrupt source corresponds to a specific vector in the exception vector table. Each vector in the exception vector table points to the beginning address of an exception handler routine.



## SECTION 10 CONFIGURABLE TIMER MODULE 4

This section is an overview of CTM4 function. Refer to the *CTM Reference Manual* (CTMRM/AD) for a comprehensive discussion of CTM capabilities.

### 10.1 General

The configurable timer module 4 (CTM4) consists of several submodules which are located on either side of the CTM4 internal submodule bus (SMB). All data and control signals within the CTM4 are passed over this bus. The SMB is connected to the outside world via the bus interface unit submodule (BIUSM), which is connected to the intermodule bus (IMB), and subsequently the CPU32. This configuration allows the CPU32 to access the data and control registers in each CTM4 submodule on the SMB. Three time base buses (TBB1, TBB2 and TBB4), each 16-bits wide, are used to transfer timing information from counters to action submodules. **Figure 10-1** shows a block diagram of the CTM4.

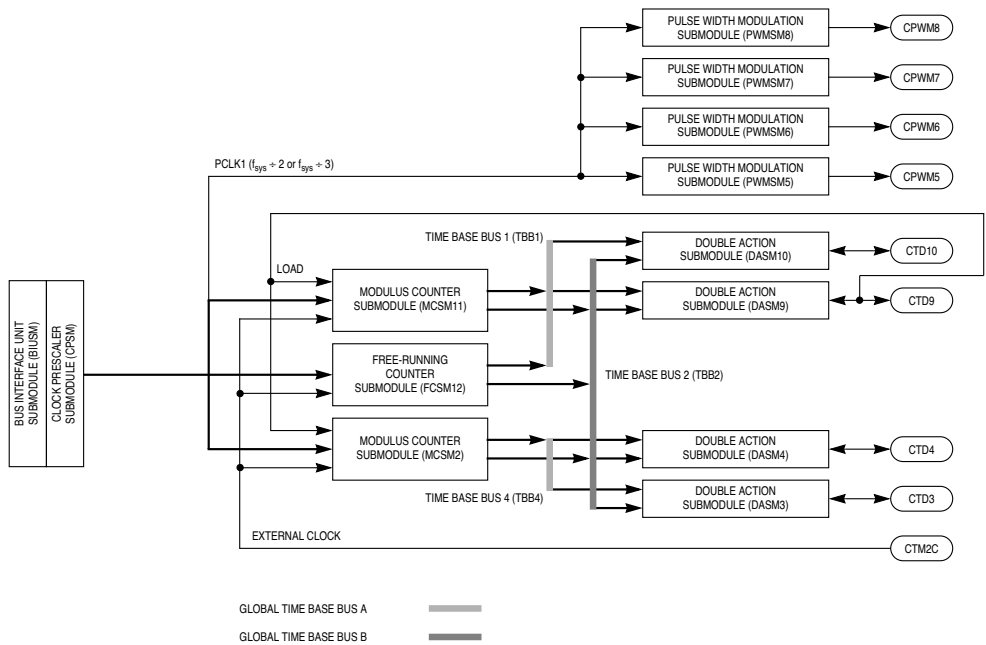

**Figure 10-1 CTM4 Block Diagram**

The time base buses originate in a counter submodule and are used by the action submodules. Two time base buses are accessible to each submodule.

The bus interface unit submodule (BIUSM) allows all the CTM4 submodules to pass data to and from the IMB via the submodule bus (SMB).

The counter prescaler submodule (CPSM) generates six different clock frequencies which can be used by any counter submodule. This submodule is contained within the BIUSM.

The free-running counter submodule (FCSM) has a 16-bit up counter with an associated clock source selector, selectable time-base bus drivers, writable control registers, readable status bits, and interrupt logic. The CTM4 has one FCSM.

The modulus counter submodule (MCSM) is an enhanced FCSM. A modulus register gives the additional flexibility of recycling the counter at a count other than 64K clock cycles. The CTM4 has two MCSMs.

The double-action submodule (DASM) provides two 16-bit input capture or two 16-bit output compare functions that can occur automatically without software intervention. The CTM4 has four DASMs.

The pulse width modulation submodule (PWMSM) can generate pulse width modulated signals over a wide range of frequencies, independently of other CTM output signals. PWMSMs are not affected by time base bus activity. The CTM4 has four PWMSMs.

## 10.2 Address Map

The CTM4 address map occupies 256 bytes from address \$YFF400 to \$YFF4FF. All CTM4 registers are accessible only when the CPU32 is in supervisor mode. All reserved addresses return zero when read, and writes have no effect. Refer to **D.7 Configurable Timer Module 4** for information concerning CTM4 address map and register bit/field descriptions.

## 10.3 Time Base Bus System

The CTM4 time base bus system is composed of three 16-bit buses: TBB1, TBB2, and TBB4. These buses are used to transfer timing information from the counter submodules to the action submodules. Two time base buses are available to each submodule. A counter submodule can drive one of the two time base buses to which it is connected. Each action submodule can choose one of the two time base buses to which it is connected as its time base. Control bits within each CTM4 submodule select connection to the appropriate time base bus.

The time base buses are precharge/discharge type buses with wired-OR capability. Therefore, no hardware damage occurs when more than one counter drives the same bus at the same time.

In the CTM4, TBB2 is global and accessible to every submodule. TBB1 and TBB4 are split to form two local time base buses. **Table 10-1** shows which time base buses are available to each CTM4 submodule.

**Table 10-1 CTM4 Time Base Bus Allocation**

Submodule	Global/Local Time Base Bus Allocation		Submodule	Global/Local Time Base Bus Allocation	
	Global Bus A	Global Bus B		Global Bus A	Global Bus B
DASM9	TBB1	TBB2	MCSM 2	TBB4	TBB2
DASM10	TBB1	TBB2	DASM 3	TBB4	TBB2
MCSM 11	TBB1	TBB2	DASM 4	TBB4	TBB2
FCSM 12	TBB1	TBB2			

Each PWMSM has an independent 16-bit counter and 8-bit prescaler clocked by the PCLK1 signal, which is generated by the CPSM. The PWMSMs are not connected to any of the time base buses. Refer to **10.9 Pulse-Width Modulation Submodule (PWMSM)** for more information.

#### 10.4 Bus Interface Unit Submodule (BIUSM)

The BIUSM connects the SMB to the IMB and allows the CTM4 submodules to communicate with the CPU32. The BIUSM also communicates CTM4 submodule interrupt requests to the IMB, and transfers the interrupt level, arbitration number and vector number to the CPU32 during the interrupt acknowledge cycle.

##### 10.4.1 STOP Effect On the BIUSM

When the CPU32 STOP instruction is executed, only the CPU32 is stopped; the CTM4 continues to operate as normal.

##### 10.4.2 Freeze Effect On the BIUSM

CTM4 response to assertion of the IMB FREEZE signal is controlled by the FRZ bit in the BIUSM configuration register (BIUMCR). Since the BIUSM propagates FREEZE to the CTM4 submodules via the SMB, the setting of FRZ affects all CTM4 submodules.

If the IMB FREEZE signal is asserted and FRZ = 1, all CTM4 submodules freeze. The following conditions apply when the CTM4 is frozen:

- All submodule registers can still be accessed.
- The CPSM, FCSM, MCSM, and PWMSM counters stop counting.
- The IN status bit still reflects the state of the FCSM external clock input pin.
- The IN2 status bit still reflects the state of the MCSM external clock input pin, and the IN1 status bit still reflects the state of the MCSM modulus load input pin.
- DASM capture and compare functions are disabled.
- The DASM IN status bit still reflects the state of its associated pin in the DIS, IPWM, IPM, and IC modes. In the OCB, OCAB, and OPWM modes, IN reflects the state of the DASM output flip flop.
- When configured for OCB, OCAB, or OPWM modes, the state of the DASM

output flip-flop will remain unchanged.

- The state of the PWMSM output flip-flop will remain unchanged.

If the IMB FREEZE signal is asserted and FRZ = 0, the freeze condition is ignored, and all CTM4 submodules will continue to operate normally.

### 10.4.3 LPSTOP Effect on the BIUSM

When the CPU32 LPSTOP instruction is executed, the system clock is stopped. All dependent modules, including the CTM4, are shut down until low-power STOP mode is exited.

### 10.4.4 BIUSM Registers

The BIUSM contains a module configuration register, a time base register, and a test register. The BIUSM register block occupies the first four register locations in the CTM4 register space. All unused bits and reserved address locations return zero when read. Writes to unused bits and reserved address locations have no effect. Refer to **D.7.1 BIU Module Configuration Register**, **D.7.2 BIUSM Test Configuration Register**, and **D.7.3 BIUSM Time Base Register** for information concerning BIUSM register and bit descriptions.

### 10.5 Counter Prescaler Submodule (CPSM)

The counter prescaler submodule (CPSM) is a programmable divider system that provides the CTM4 counters with a choice of six clock signals (PCLK[1:6]) derived from the main MCU system clock. Five of these frequencies are derived from a fixed divider chain. The divide ratio of the last clock frequency is software selectable from a choice of four divide ratios.

The CPSM is part of the BIUSM. **Figure 10-2** shows a block diagram of the CPSM.

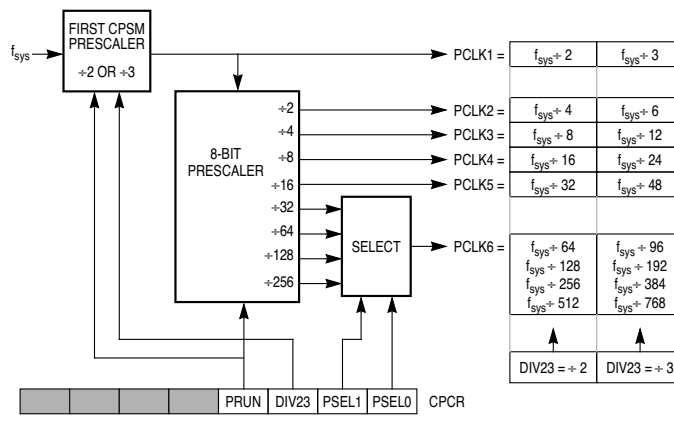

**Figure 10-2 CPSM Block Diagram**

## 10.5.1 CPSM Registers

The CPSM contains a control register (CPCR) and a test register (CPTR). All unused bits and reserved address locations return zero when read. Writes to unused bits and reserved address locations have no effect. Refer to **D.7.4 CPSM Control Register** and **D.7.5 CPSM Test Register** for information concerning CPSM register and bit descriptions.

## 10.6 Free-Running Counter Submodule (FCSM)

The free-running counter submodule (FCSM) has a 16-bit up counter with an associated clock source selector, selectable time-base bus drivers, control registers, status bits, and interrupt logic. When the 16-bit up counter overflows from \$FFFF to \$0000, an optional overflow interrupt request can be generated. The current state of the 16-bit counter is the primary output of the counter submodules. The user can select which, if any, time base bus is to be driven by the 16-bit counter. A software control register selects whether the clock input to the counter is one of the taps from the prescaler or an input pin. The polarity of the external input pin is also programmable.

In order to count, the FCSM requires the CPSM clock signals to be present. After reset, the FCSM does not count until the prescaler in the CPSM starts running (when the software sets the PRUN bit). This allows all counters in the CTM4 submodules to be synchronized.

The CTM4 has one FCSM. **Figure 10-3** shows a block diagram of the FCSM.

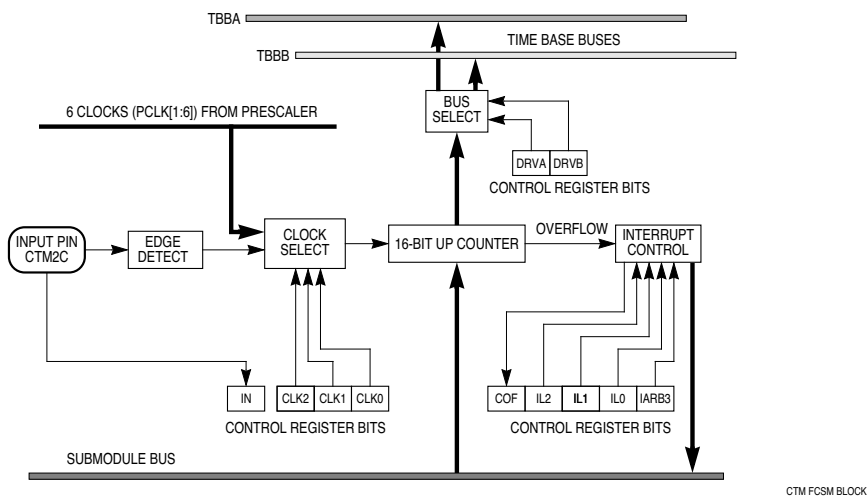

**Figure 10-3 FCSM Block Diagram**

### 10.6.1 FCSM Counter

The FCSM counter consists of a 16-bit register and a 16-bit up-counter. Reading the register transfers the contents of the counter to the data bus, while a write to the register loads the counter with a new value. Overflow of the counter is defined to be the transition from \$FFFF to \$0000. An overflow condition sets the counter overflow flag (COF) in the FCSM status/interrupt/control register (FCSMSIC).

#### NOTE

Reset presets the counter register to \$0000. Writing \$0000 to the counter register while the counter's value is \$FFFF does not set the COF flag and does not generate an interrupt request.

### 10.6.2 FCSM Clock Sources

The FCSM has eight software selectable counter clock sources, including:

- Six CPSM prescaler outputs (PCLK[1:6])
- Rising edge on CTM2C input
- Falling edge on the CTM2C input

The clock source is selected by the CLK[2:0] bits in FCSMSIC. When the CLK[2:0] bits are being changed, internal circuitry guarantees that spurious edges occurring on the CTM2C pin do not affect the FCSM. The read-only IN bit in FCSMSIC reflects the state of CTM2C. This pin is Schmitt-triggered and is synchronized with the system clock. The maximum allowable frequency for a clock input on CTM2C is  $f_{sys}/4$ .

### 10.6.3 FCSM External Event Counting

When an external clock source is selected, the FCSM can act as an event counter simply by counting the number of events occurring on the CTM2C input pin. Alternatively, the FCSM can be programmed to generate an interrupt request when a pre-defined number of events have been counted. This is done by presetting the counter with the two's complement value of the desired number of events.

### 10.6.4 FCSM Time Base Bus Driver

The DRVA and DRVB bits in FCSMSIC select the time base bus to be driven. Which of the time base buses is driven depends on where the FCSM is physically placed in any particular CTM implementation. Refer to **Figure 10-1** and **Table 10-1** for more information.

#### WARNING

Two time base buses should not be driven at the same time.

### 10.6.5 FCSM Interrupts

The FCSM can optionally request an interrupt when its counter overflows and the COF bit in FCSMSIC is set. To enable interrupts, set the IL[2:0] field in the FCSMSIC to a non-zero value. The CTM4 compares the CPU32 IP mask value to the priority of the requested interrupt designated by IL[2:0] to determine whether it should contend for

arbitration priority. During arbitration, the BIUSM provides the arbitration value specified by IARB[2:0] in BIUMCR and IARB3 in FCSMSIC. If the CTM4 wins arbitration, it responds with a vector number generated by concatenating VECT[7:6] in BIUMCR and the six low-order bits specified by the number of the submodule requesting service. Thus, for FCSM12 in CTM4, six low-order bits would be 12 in decimal, or %001100 in binary.

### 10.6.6 FCSM Registers

The FCSM contains a status/interrupt/control register and a counter register. All unused bits and reserved address locations return zero when read. Writes to unused bits and reserved address locations have no effect. Refer to **D.7.6 FCSM Status/Interrupt/Control Register** and **D.7.7 FCSM Counter Register** for information concerning FCSM register and bit descriptions.

### 10.7 Modulus Counter Submodule (MCSM)

The modulus counter submodule (MCSM) is an enhanced FCSM. The MCSM contains a 16-bit modulus latch, a 16-bit loadable up-counter, counter loading logic, a clock selector, selectable time base bus drivers, and an interrupt interface. A modulus register provides the added flexibility of recycling the counter at a count other than 64K clock cycles. The content of the modulus latch is transferred to the counter when an overflow occurs, or when a user-specified edge transition occurs on a designated modulus load input pin. In addition, a write to the modulus counter simultaneously loads both the counter and the modulus latch with the specified value. The counter then begins incrementing from this new value.

In order to count, the MCSM requires the CPSM clock signals to be present. After reset, the MCSM does not count until the prescaler in the CPSM starts running (when the software sets the PRUN bit). This allows all counters in the CTM4 submodules to be synchronized.

The CTM4 contains two MCSMs. **Figure 10-4** shows a block diagram of the MCSM.

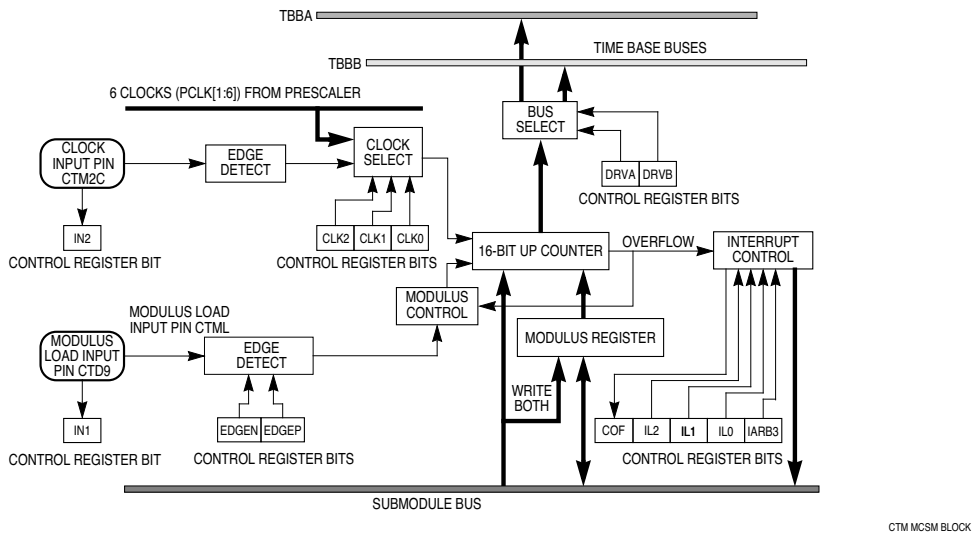

**Figure 10-4 MCSM Block Diagram**

### 10.7.1 MCSM Modulus Latch

The 16-bit modulus latch is a read/write register that is used to reload the counter automatically with a predetermined value. The contents of the modulus latch register can be read at any time. Writing to the register loads the modulus latch with the new value. This value is then transferred to the counter register when the next load condition occurs. However, writing to the corresponding counter register loads the modulus latch and the counter register immediately with the new value. The modulus latch register is cleared to \$0000 by reset.

### 10.7.2 MCSM Counter

The counter is composed of a 16-bit read/write register associated with a 16-bit incrementer. Reading the counter transfers the contents of the counter register to the data bus. Writing to the counter loads the modulus latch and the counter register immediately with the new value.

#### 10.7.2.1 Loading the MCSM Counter Register

The MCSM counter is loaded either by writing to the counter register or by loading it from the modulus latch when a counter overflow occurs. Counter overflow will set the COF bit in the MCSM status/interrupt/control register (MCSMSIC).

#### NOTE

When the modulus latch is loaded with \$FFFF, the overflow flag is set on every counter clock pulse.



### 10.7.2.2 Using the MCSM as a Free-Running Counter

Although the MCSM is a modulus counter, it can operate like a free-running counter by loading the modulus register with \$0000.

### 10.7.3 MCSM Clock Sources

The MCSM has eight software selectable counter clock sources, including:

- Six CPSM prescaler outputs (PCLK[1:6])
- Rising edge on the CTM2C input
- Falling edge on the CTM2C input

The clock source is selected by the CLK[2:0] bits in MCSMSIC. When the CLK[2:0] bits are being changed, internal circuitry guarantees that spurious edges occurring on the CTM2C pin do not affect the MCSM. The read only IN2 bit in MCSMSIC reflects the state of CTM2C. This pin is Schmitt-triggered, and is synchronized with the system clock. The maximum allowable frequency for a clock signal input on CTM2C is  $f_{\text{sys}}/4$ .

### 10.7.4 MCSM External Event Counting

When an external clock source is selected, the MCSM can act as an event counter simply by counting the number of events occurring on the CTM2C input pin. Alternatively, the MCSM can be programmed to generate an interrupt when a predefined number of events have been counted. This is done by presetting the counter with the two's complement value of the desired number of events.

### 10.7.5 MCSM Time Base Bus Driver

The DRVA and DRVB bits in MCSMSIC select the time base bus to be driven. Which of the time base buses is driven depends on where the MCSM is physically placed in any particular CTM implementation. Refer to **Figure 10-1** and **Table 10-1** for more information.

#### WARNING

Two time base buses should not be driven at the same time.

### 10.7.6 MCSM Interrupts

The MCSM can optionally request an interrupt when its counter overflows and the COF bit in MCSMSIC is set. To enable interrupts, set the IL[2:0] field in the MCSMSIC to a non-zero value. The CTM4 compares the CPU32 IP mask value to the priority of the requested interrupt designated by IL[2:0] to determine whether it should contend for arbitration priority. During arbitration, the BIUSM provides the arbitration value specified by IARB[2:0] in BIUMCR and IARB3 in MCSMSIC. If the CTM4 wins arbitration, it responds with a vector number generated by concatenating VECT[7:6] in BIUMCR and the six low-order bits specified by the number of the submodule requesting service. Thus, for MCSM12 in CTM4, six low-order bits would be 12 in decimal, or %001100 in binary.

## 10.7.7 MCSM Registers

The MCSM contains a status/interrupt/control register, a counter, and a modulus latch. All unused bits and reserved address locations return zero when read. Writes to unused bits and reserved address locations have no effect. The CTM4 contains three MCSMs, each with its own set of registers. Refer to **D.7.8 MCSM Status/Interrupt/Control Registers**, **D.7.9 MCSM Counter Registers**, and **D.7.10 MCSM Modulus Latch Registers** for information concerning MCSM register and bit descriptions.

## 10.8 Double-Action Submodule (DASM)

The double-action submodule (DASM) allows two 16-bit input capture or two 16-bit output compare functions to occur automatically without software intervention. The input edge detector can be programmed to trigger the capture function on user-specified edges. The output flip flop can be set by one of the output compare functions, and reset by the other one. Interrupt requests can optionally be generated by the input capture and the output compare functions. The user can select one of two incoming time bases for the input capture and output compare functions.

Six operating modes allow the DASM input capture and output compare functions to perform pulse width measurement, period measurement, single pulse generation, and continuous pulse width modulation, as well as standard input capture and output compare. The DASM can also function as a single I/O pin.

DASM operating mode is determined by the mode select field (MODE[3:0]) in the DASM status/interrupt/control register (DASMSIC). **Table 10-2** shows the different DASM operating modes.

**Table 10-2 DASM Modes of Operation**

MODE[3:0]	Mode	Description of Mode
0000	DIS	Disabled — Input pin is high impedance; IN gives state of input pin
0001	IPWM	Input pulse width measurement — Capture on leading edge and the trailing edge of an input pulse
0010	IPM	Input period measurement — Capture two consecutive rising/falling edges
0011	IC	Input capture — Capture when the designated edge is detected
0100	OCB	Output compare, flag set on B compare — Generate leading and trailing edges of an output pulse and set the flag
0101	OCAB	Output compare, flag set on A and B compare — Generate leading and trailing edges of an output pulse and set the flag
0110	—	Reserved
0111	—	Reserved
1xxx	OPWM	Output pulse width modulation — Generate continuous PWM output with 7, 9, 11, 12, 13, 14, 15, or 16 bits of resolution

The DASM is composed of two timing channels (A and B), an output flip-flop, an input edge detector, some control logic and an interrupt interface. All control and status bits are contained in DASMSIC.

Channel A consists of one 16-bit data register and one 16-bit comparator. To the user, channel B also appears to consist of one 16-bit data register and one 16-bit compar-

ator, though internally, channel B has two data registers (B1 and B2). DASM operating mode determines which register is software accessible. Refer to **Table 10-3**.

**Table 10-3 Channel B Data Register Access**

Mode	Data Register
Input Capture (IPWM, IPM, IC)	Registers A and B2 are used to hold the captured values. In these modes, the B1 register is used as a temporary latch for channel B.
Output Compare (OCA, OCAB)	Registers A and B2 are used to define the output pulse. Register B1 is not used in these modes.
Output Pulse Width Modulation Mode (OPWM)	Registers A and B1 are used as primary registers and hidden register B2 is used as a double buffer for channel B.

Register contents are always transferred automatically at the correct time so that the minimum pulse (measured or generated) is just one time base bus count. The A and B data registers are always read/write registers, accessible via the CTM4 submodule bus.

The CTM4 has four DASMs. **Figure 10-5** shows a block diagram of the DASM.

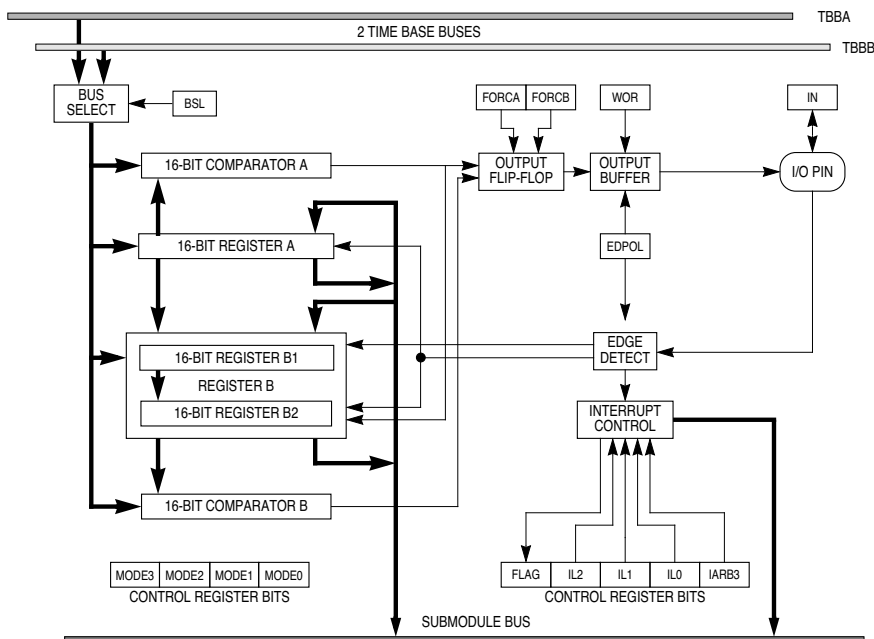

CTM DASM BLOCK

**Figure 10-5 DASM Block Diagram**

### 10.8.1 DASM Interrupts

The DASM can optionally request an interrupt when the FLAG bit in DASMSIC is set. To enable interrupts, set the IL[2:0] field in DASMSIC to a non-zero value. The CTM4 compares the CPU32 IP mask value to the priority of the requested interrupt designated by IL[2:0] to determine whether it should contend for arbitration priority. During arbitration, the BIUSM provides the arbitration value specified by IARB[2:0] in BIUMCR and IARB3 in DASMSIC. If the CTM4 wins arbitration, it responds with a vector number generated by concatenating VECT[7:6] in BIUMCR and the six low-order bits specified by the number of the submodule requesting service. Thus, for DASM9 in the CTM4, the six low-order bits would be nine in decimal, or %001001 in binary.

### 10.8.2 DASM Registers

The DASM contains one status/interrupt/control register and two data registers (A and B). All unused bits and reserved address locations return zero when read. Writes to unused bits and reserved address locations have no effect. The CTM4 contains four DASMs, each with its own set of registers. Refer to **D.7.11 DASM Status/Interrupt/Control Registers**, **D.7.12 DASM Data Register A**, and **D.7.13 DASM Data Register B** for information concerning DASM register and bit descriptions.

## 10.9 Pulse-Width Modulation Submodule (PWMSM)

The PWMSM allows pulse width modulated signals to be generated over a wide range of frequencies, independently of other CTM4 output signals. The output pulse width duty cycle can vary from 0% to 100%, with 16 bits of resolution. The minimum pulse width is twice the MCU system clock period. For example, the minimum pulse width is 95.4 ns when using a 20.97 MHz clock.

The PWMSM is composed of:

- An output flip-flop with output polarity control
- Clock prescaler and selection logic
- A 16-bit up-counter
- Two registers to hold the current and next pulse width values
- Two registers to hold the current and next pulse period values
- A pulse width comparator
- A system state sequencer
- Logic to create 0% and 100% pulses
- Interrupt logic
- A status, interrupt and control register
- A submodule bus interface

The PWMSM includes its own time base counter and does not use the CTM4 time base buses; however, it does use the prescaled clock signal PCLK1 generated by the CPSM. Refer to **10.5 Counter Prescaler Submodule (CPSM)** and **Figure 10-1** for more information. **Figure 10-6** shows a block diagram of the PWMSM.

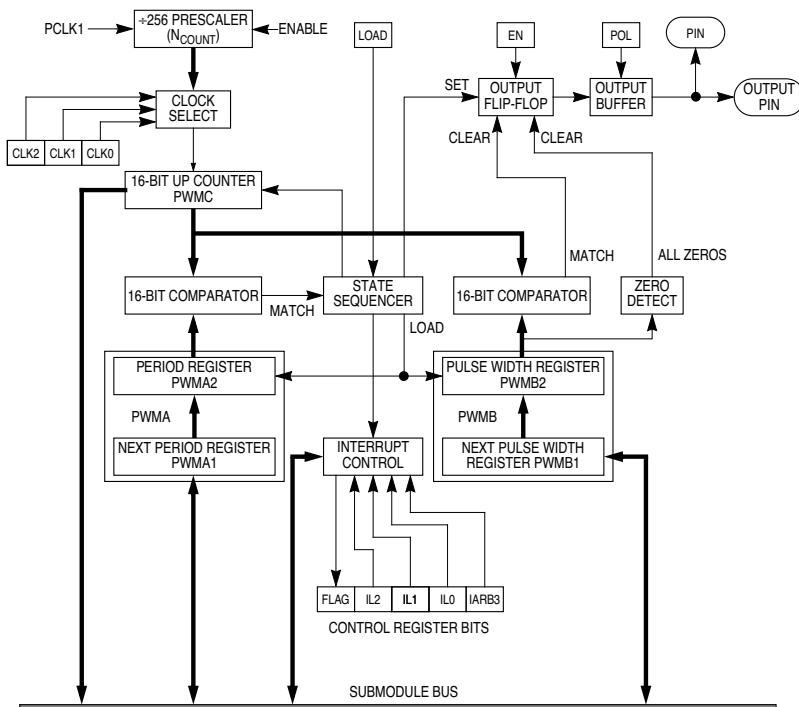

CTM PWM BLOCK

**Figure 10-6 Pulse-Width Modulation Submodule Block Diagram**

### 10.9.1 Output Flip-Flop and Pin

The output flip-flop is the basic output mechanism of the PWMSM. Except when the required duty cycle is 0% or 100%, the output flip-flop is set at the beginning of each period and is cleared at the end of the designated pulse width. The polarity of the output pulse is user programmable. The output flip-flop is connected to a buffer that drives the PWMSM's associated output pin. The PWMSM is disabled by clearing the EN bit in the PWMSM status/interrupt/control register (PWMSIC). When the PWMSM is not in use, the output pin can be used as a digital output controlled by the POL bit in PWMSIC.

### 10.9.2 Clock Selection

The PWMSM contains an 8-bit prescaler that is clocked by the PCLK1 signal ( $f_{\text{sys}} \div 2$  or  $f_{\text{sys}} \div 3$ ) from the CPSM. The CLK[2:0] field in PWMSIC selects which of the eight prescaler outputs drives the PWMSM counter. Refer to **Table 10-4** for the prescaler output.

**Table 10-4 PWMSM Divide By Options**

CLK2	CLK1	CLK0	PCLK1 = $f_{sys} \div 2$ (CPCR DIV23 = 0)	PCLK1 = $f_{sys} \div 3$ (CPCR DIV23 = 0)
0	0	0	$f_{sys} \div 2$	$f_{sys} \div 3$
0	0	1	$f_{sys} \div 4$	$f_{sys} \div 6$
0	1	0	$f_{sys} \div 8$	$f_{sys} \div 12$
0	1	1	$f_{sys} \div 16$	$f_{sys} \div 24$
1	0	0	$f_{sys} \div 32$	$f_{sys} \div 48$
1	0	1	$f_{sys} \div 64$	$f_{sys} \div 96$
1	1	0	$f_{sys} \div 128$	$f_{sys} \div 192$
1	1	1	$f_{sys} \div 512$	$f_{sys} \div 768$

### 10.9.3 PWMSM Counter

The 16-bit up counter in the PWMSM provides the time base for the PWM output signal. The counter is held in the \$0001 state after reset or when the PWMSM is disabled. When the PWMSM is enabled, the counter begins counting at the rate selected by CLK[2:0] in PWMSIC. Each time the counter matches the contents of the period register, the counter is preset to \$0001 and starts to count from that value. The counter can be read at any time from the PWMC register without affecting its value. Writing to the counter has no effect.

### 10.9.4 PWMSM Period Registers and Comparator

The period section of the PWMSM consists of two 16-bit period registers (PWMA1 and PWMA2) and one 16-bit comparator. PWMA2 holds the current PWM period value, and PWMA1 holds the next PWM period value. The next period of the output PWM signal is established by writing a value into PWMA1. PWMA2 acts as a double buffer for PWMA1, allowing the contents of PWMA1 to be changed at any time without affecting the period of the current output signal. PWMA2 is not user accessible. PWMA1 can be read or written at any time. The new value in PWMA1 is transferred to PWMA2 on the next full cycle of the PWM output or when a one is written to the LOAD bit in PWMSIC.

The comparator continuously compares the contents of PWMA2 with the value in the PWMSM counter. When a match occurs, the state sequencer sets the output flip-flop and resets the counter to \$0001.

Period values \$0000 and \$0001 are special cases. When PWMA2 contains \$0000, an output period of 65536 PWM clock periods is generated.

When PWMA2 contains \$0001, a period match occurs on every PWM clock period. The counter never increments beyond \$0001, and the output level never changes.

#### NOTE

Values of \$0002 in the period register (PWMA2) and \$0001 in the pulse width register (PWMB2) result in the maximum possible output frequency for a given PWM counter clock frequency.

### 10.9.5 PWMSM Pulse-Width Registers and Comparator

The pulse width section of the PWMSM consists of two 16-bit pulse width registers (PWMB1 and PWMB2) and one 16-bit comparator. PWMB2 holds the current PWM pulse width value, and PWMB1 holds the next PWM pulse width value. The next pulse width of the output PWM signal is established by writing a value into PWMB1. PWMB2 acts as a double buffer for PWMB1, allowing the contents of PWMB1 to be changed at any time without affecting the pulse width of the current output signal. PWMB2 is not user accessible. PWMB1 can be read or written at any time. The new value in PWMB1 is transferred to PWMB2 on the next full cycle of the output or when a one is written to the LOAD bit in PWMSIC.

The comparator continuously compares the contents of PWMB2 with the counter. When a match occurs, the output flip-flop is cleared. This pulse width match completes the pulse width, however, it does not affect the counter.

The PWM output pulse may be as short as one PWM counter clock period (PWMB2 = \$0001). It may be as long as one PWM clock period less than the PWM period. For example, a pulse width equal to 65535 PWM clock periods can be obtained by setting PWMB2 to \$FFFF and PWMA2 to \$0000.

### 10.9.6 PWMSM Coherency

Access to PWMSM registers can be accomplished with 16-bit transfers in most cases. The PWMSM treats a 32-bit access as two 16-bit accesses, except when the access is a write to the period and pulse width registers. A single long word write can set both PWMA1 and PWMB1 because they occupy subsequent memory addresses. If the write can be completed within the current PWM period, there is no visible effect on the output signal. New values loaded into PWMA1 and PWMB1 will be transferred into PWMA2 and PWMB2 at the start of the next period. If the write coincides with the end of the current PWM period, the transfer of values from PWMA1 and PWMB1 into PWMA2 and PWMB2 will be suppressed until the end of the next period. This prevents undesired glitches on the output signal. During the period that is output before the suppressed transfer completes, the current values in PWMA2 and PWMB2 are used.

### 10.9.7 PWMSM Interrupts

The FLAG bit in PWMSIC is set when a new PWM period begins and indicates that the period and pulse width registers (PWMA1 and PWMB1) may be updated with new values for the next output period. The PWMSM can optionally request an interrupt when FLAG is set. To enable interrupts, set the IL[2:0] field in PWMSIC to a non-zero value. The CTM4 compares the CPU32 IP mask value to the priority of the requested interrupt designated by IL[2:0] to determine whether it should contend for arbitration priority.

During arbitration, the BIUSM provides the arbitration value specified by IARB[2:0] in BIUMCR and IARB3 in PWMSIC. If the CTM4 wins arbitration, it responds with a vector number generated by concatenating VECT[7:6] in BIUMCR and the six low-order bits specified by the number of the submodule requesting service. Thus, for PWMSM8 in the CTM4, the six low-order bits would be eight in decimal, or %00100 in binary.

## 10.9.8 PWM Frequency

The relationship between the PWM output frequency ( $f_{PWM}$ ) and the MCU system clock frequency ( $f_{sys}$ ) is given by the following equation:

$$f_{PWM} = \frac{f_{sys}}{N_{CLOCK} \cdot N_{PERIOD}}$$

where  $N_{CLOCK}$  is the divide ratio specified by the CLK[2:0] field in PWMSIC and  $N_{PERIOD}$  is the period specified by PWMA1.

The minimum PWM output frequency achievable with a specified number of bits of resolution for a given system clock frequency is:

$$\text{Minimum } f_{PWM} = \frac{f_{sys}}{256N_{CPSM} \cdot 2^{\text{Bits of Resolution}}}$$

where  $N_{CPSM}$  is the CPSM divide ratio of two or three.

Similarly, the maximum PWM output frequency achievable with a specified number of bits of resolution for a given system clock frequency is:

$$\text{Maximum } f_{PWM} = \frac{f_{sys}}{N_{CPSM} \cdot 2^{\text{Bits of Resolution}}}$$

**Tables 10-5 and 10-6** summarize the minimum pulse widths and frequency ranges available from the PWMSM based on the CPSM system clock divide ratio and a system clock frequency of 20.97 MHz.

**Table 10-5 PWM Pulse and Frequency Ranges (in Hz) Using ÷ 2 Option (20.97 MHz)**

$f_{sys}$ Divide Ratio	Minimum Pulse Width	Bits of Resolution															
		16	15	14	13	12	11	10	9	8	7	6	5	4	3	2	1
+ 2	0.095 $\mu$ s	160	320	640	1280	2560	5120	10239	20479	40957	81914	164K	328K	655K	1311K	2621K	5243K
+ 4	0.191 $\mu$ s	80	160	320	640	1280	2560	5120	10239	20479	40957	81914	164K	328K	655K	1311K	2621K
+ 8	0.381 $\mu$ s	40	80	160	320	640	1280	2560	5120	10239	20479	40957	81914	164K	328K	655K	1311K
+ 16	0.763 $\mu$ s	20	40	80	160	320	640	1280	2560	5120	10239	20479	40957	81914	164K	328K	655K
+ 32	1.53 $\mu$ s	10	20	40	80	160	320	640	1280	2560	5120	10239	20479	40957	81914	164K	328K
+ 64	3.05 $\mu$ s	5	10	20	40	80	160	320	640	1280	2560	5120	10239	20479	40957	81914	164K
+ 128	6.10 $\mu$ s	2.5	5	10	20	40	80	160	320	640	1280	2560	5120	10239	20479	40957	81914
+ 512	24.42 $\mu$ s	0.6	1.3	2.5	5	10	20	40	80	160	320	640	1280	2560	5120	10239	20479

**Table 10-6 PWM Pulse and Frequency Ranges (in Hz) Using ÷ 3 Option (20.97 MHz)**

$f_{sys}$ Divide Ratio	Minimum Pulse Width	Bits of Resolution															
		16	15	14	13	12	11	10	9	8	7	6	5	4	3	2	1
+ 3	0.179 $\mu$ s	107	224	427	853	1707	3413	6826	13652	27305	54609	109K	218K	437K	874K	1748K	3495K
+ 6	0.358 $\mu$ s	53	107	224	427	853	1707	3413	6826	13652	27305	54609	109K	218K	437K	874K	1748K
+ 12	0.715 $\mu$ s	27	53	107	224	427	853	1707	3413	6826	13652	27305	54609	109K	218K	437K	874K
+ 24	1.431 $\mu$ s	13	27	53	107	224	427	853	1707	3413	6826	13652	27305	54609	109K	218K	437K
+ 48	2.861 $\mu$ s	7	13	27	53	107	224	427	853	1707	3413	6826	13652	27305	54609	109K	218K
+ 96	5.722 $\mu$ s	3	7	13	27	53	107	224	427	853	1707	3413	6826	13652	27305	54609	109K
+ 192	11.44 $\mu$ s	2	3	7	13	27	53	107	224	427	853	1707	3413	6826	13652	27305	54609
+ 768	45.78 $\mu$ s	0.4	0.8	2	3	7	13	27	53	107	224	427	853	1707	3413	6826	13652



### 10.9.9 PWM Pulse Width

The shortest output pulse width ( $t_{PWMIN}$ ) that can be obtained is given by the following equation:

$$t_{PWMIN} = \frac{N_{CLOCK}}{f_{sys}}$$

The maximum output pulse width ( $t_{PWMAX}$ ) that can be obtained is given by the following equation:

$$t_{PWMAX} = \frac{N_{CLOCK} \cdot (N_{PERIOD} - 1)}{f_{sys}}$$

#### 10.9.10 PWM Period and Pulse Width Register Values

The value loaded into PWMA1 to obtain a given period is:

$$PWMA1 = \frac{f_{sys}}{N_{CLOCK} \cdot f_{PWM}}$$

The value loaded into PWMB1 to obtain a given duty cycle is:

$$PWMB1 = \frac{1}{t_{PWMIN} \cdot f_{PWM}} = \frac{\text{Duty Cycle \%}}{100} \cdot PWMA1$$

##### 10.9.10.1 PWM Duty Cycle Boundary Cases

PWM duty cycles 0% and 100% are special boundary cases (zero pulse width and infinite pulse width) that are defined by the “always clear” and “always set” states of the output flip-flop.

A zero width pulse is generated by setting PWMB2 to \$0000. The output is a true steady state signal. An infinite width pulse is generated by setting PWMB2 equal to or greater than the period value in PWMA2. In both cases, the state of the output pin will remain unchanged at the polarity defined by the POL bit in PWMSIC.

#### NOTE

A duty cycle of 100% is not possible when the output period is set to 65536 PWM clock periods (which occurs when PWMB2 is set to \$0000). In this case, the maximum duty cycle is 99.998% ( $100 \times 65535/65536$ ).

Even when the duty cycle is 0% or 100%, the PWMSM counter continues to count.

##### 10.9.11 PWMSM Registers

The PWMSM contains a status/interrupt/control register, a period register, a pulse width register, and a counter register. All unused bits and reserved address locations return zero when read. Writes to unused bits and reserved address locations have no effect. The CTM4 contains four PWMSMs, each with its own set of registers. Refer to

**D.7.14 PWM Status/Interrupt/Control Register, D.7.15 PWM Period Register, D.7.16 PWM Pulse Width Register, and D.7.17 PWM Counter Register** for information concerning PWMSM register and bit descriptions.

## 10.10 CTM4 Interrupts

The CTM4 is able to generate as many as eleven requests for interrupt service. Each submodule capable of requesting an interrupt can do so on any of seven levels. Submodules that can request interrupt service have a 3-bit level number and a 1-bit arbitration number that is user-initialized.

The 3-bit level number selects which of seven interrupt signals on the IMB are driven by that submodule to generate an interrupt request. Of the four priority bits provided by the IMB to the CTM4 for interrupt arbitration, one of them comes from the chosen submodule, and the BIUSM provides the other three. Thus, the CTM4 can respond with two of the 15 possible arbitration numbers.

During the IMB arbitration process, the BIUSM manages the separate arbitration among the CTM4 submodules to determine which submodule should respond. The CTM4 has a fixed hardware prioritization scheme for all submodules. When two or more submodules have an interrupt request pending at the level being arbitrated on the IMB, the submodule with the lowest number (also the lowest status/interrupt/control register address) is given the highest priority to respond.

If the CTM4 wins arbitration, it responds with a vector number generated by concatenating VECT[7:6] in BIUMCR and the six low-order bits specified by the number of the submodule requesting service. **Table 10-7** shows the allocation of CTM4 submodule numbers and interrupt vector numbers.

**Table 10-7 CTM4 Interrupt Priority and Vector/Pin Allocation**

Submodule Name	Submodule Number	Submodule Base Address	Submodule Binary Vector Number
BIUSM	0	\$YFF400 <sup>1</sup>	None
CPSM	1	\$YFF408	None
MCSM2	2	\$YFF410	xx000010 <sup>2</sup>
DASM3	3	\$YFF418	xx000011
DASM4	4	\$YFF420	xx000100
PWSM5	5	\$YFF428	xx000101
PWSM6	6	\$YFF430	xx000110
PWSM7	7	\$YFF438	xx000111
PWSM8	8	\$YFF440	xx001000
DASM9	9	\$YFF448	xx001001
DASM10	10	\$YFF450	xx001010
MCSM11	11	\$YFF458	xx001011
FCSM12	12	\$YFF460	xx001100

NOTES:

1. Y = M111, where M is the state of the MM bit in SIMCR (Y = \$7 or \$F).
2. "xx" represents VECT[7:6] in the BIUSM module configuration register.

## SECTION 11 TIME PROCESSOR UNIT

The time processor unit (TPU) is an intelligent, semi-autonomous microcontroller designed for timing control. Operating simultaneously with the CPU32, the TPU schedules tasks, processes microcode ROM instructions, accesses shared data with the CPU32, and performs input and output functions. **Figure 11-1** is a simplified block diagram of the TPU.

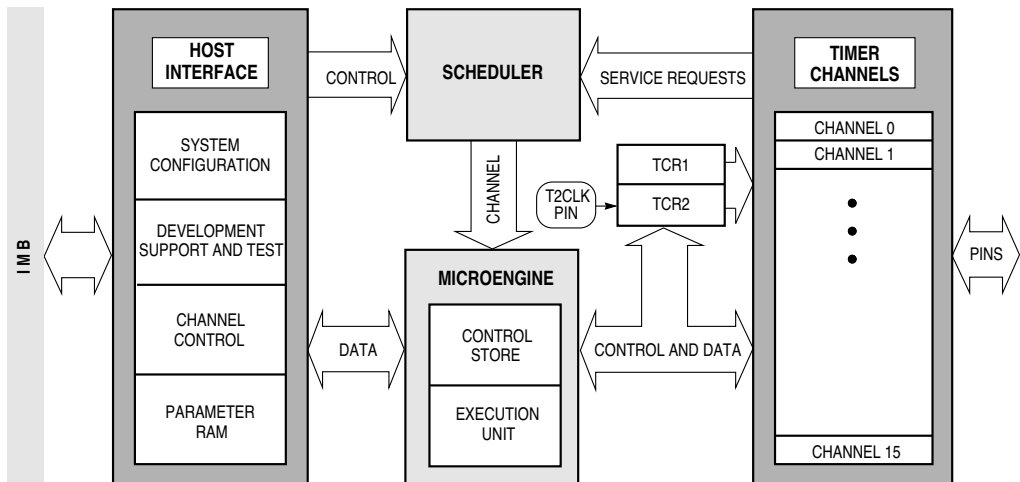

TPU BLOCK

**Figure 11-1 TPU Block Diagram**

### 11.1 General

The TPU can be viewed as a special-purpose microcomputer that performs a programmable series of two operations, match and capture. Each occurrence of either operation is called an event. A programmed series of events is called a function. TPU functions replace software functions that would require CPU32 interrupt service. Two sets of microcode ROM functions are currently available for most MCU derivatives with the TPU.

The A mask set (or original mask set) includes the following functions:

- Discrete input/output
- Input capture/input transition counter
- Output compare
- Pulse width modulation

- Synchronized pulse width modulation
- Period measurement with additional transition detect
- Period measurement with missing transition detect
- Position-synchronized pulse generator
- Stepper motor
- Period/pulse width accumulator
- Quadrature decode

The G mask set (or motion control mask set) includes the following functions:

- Table stepper motor
- New input capture/transition counter
- Queued output match
- Programmable time accumulator
- Multichannel pulse width modulation
- Fast quadrature decode
- Universal asynchronous receiver/transmitter
- Brushless motor communication
- Frequency measurement
- Hall effect decode

## 11.2 TPU Components

The TPU consists of two 16-bit time bases, sixteen independent timer channels, a task scheduler, a microengine, and a host interface. In addition, a dual-ported parameter RAM is used to pass parameters between the module and the CPU32.

### 11.2.1 Time Bases

Two 16-bit counters provide reference time bases for all output compare and input capture events. Prescalers for both time bases are controlled by the CPU32 via bit fields in the TPU module configuration register (TPUMCR). Timer count registers TCR1 and TCR2 provide access to the current counter values. TCR1 and TCR2 can be read by TPU microcode, but are not directly available to the CPU32. The TCR1 clock is derived from the system clock. The TCR2 clock can be derived from the system clock or from an external clock input via the T2CLK pin.

### 11.2.2 Timer Channels

The TPU has 16 independent channels, each connected to an MCU pin. The channels have identical hardware. Each channel consists of an event register and pin control logic. The event register contains a 16-bit capture register, a 16-bit compare/match register, and a 16-bit greater-than-or-equal-to comparator. The direction of each pin, either output or input, is determined by the TPU microengine. Each channel can either use the same time base for match and capture, or can use one time base for match and the other for capture.

### 11.2.3 Scheduler

When a service request is received, the scheduler determines which TPU channel is serviced by the microengine. A channel can request service for one of four reasons: for host service, for a link to another channel, for a match event, or for a capture event. The host system assigns each active channel one of three priorities: high, middle, or low. When multiple service requests are received simultaneously, a priority-scheduling mechanism grants service based on channel number and assigned priority.

### 11.2.4 Microengine

The microengine is composed of a control store and an execution unit. Control-store ROM holds the microcode for each factory-masked time function. When assigned to a channel by the scheduler, the execution unit executes microcode for a function assigned to that channel by the CPU32. Microcode can also be executed from the TPURAM module instead of the control store. The TPURAM allows emulation and development of custom TPU microcode without the generation of a microcode ROM mask. Refer to **11.3.6 Emulation Support** for more information.

### 11.2.5 Host Interface

The host interface registers allow communication between the CPU32 and the TPU, both before and during execution of a time function. The registers are accessible from the IMB through the TPU bus interface unit. Refer to **11.6 Host Interface Registers** and **D.8 Time Processor Unit (TPU)** for register bit/field definitions and address mapping.

### 11.2.6 Parameter RAM

Parameter RAM occupies 256 bytes at the top of the system address map. Channel parameters are organized as 128 16-bit words. Although all parameter word locations in RAM can be accessed by all channels, only 100 are normally used: channels 0 to 13 use six parameter words, while channels 14 and 15 each use eight parameter words. The parameter RAM address map in **D.8.15 TPU Parameter RAM** shows how parameter words are organized in memory.

The CPU32 specifies function parameters by writing to the appropriate RAM address. The TPU reads the RAM to determine channel operation. The TPU can also store information to be read by the CPU32 in the parameter RAM. Detailed descriptions of the parameters required by each time function are beyond the scope of this manual. Refer to the *TPU Reference Manual* (TPURM/AD) and the Motorola TPU Literature Package (TPULITPAK/D) for more information.

## 11.3 TPU Operation

All TPU functions are related to one of the two 16-bit time bases. Functions are synthesized by combining sequences of match events and capture events. Because the primitives are implemented in hardware, the TPU can determine precisely when a match or capture event occurs, and respond rapidly. An event register for each channel provides for simultaneity of match/capture event occurrences on all channels.

When a match or input capture event requiring service occurs, the affected channel generates a service request to the scheduler. The scheduler determines the priority of the request and assigns the channel to the microengine at the first available time. The microengine performs the function defined by the content of the control store or emulation RAM, using parameters from the parameter RAM.

### **11.3.1 Event Timing**

Match and capture events are handled by independent channel hardware. This provides an event accuracy of one time-base clock period, regardless of the number of channels that are active. An event normally causes a channel to request service. The time needed to respond to and service an event is determined by which channels and the number of channels requesting service, the relative priorities of the channels requesting service, and the microcode execution time of the active functions. Worst-case event service time (latency) determines TPU performance in a given application. Latency can be closely estimated. For more information, refer to the *TPU Reference Manual* (TPURM/AD)

### **11.3.2 Channel Orthogonality**

Most timer systems are limited by the fixed number of functions assigned to each pin. All TPU channels contain identical hardware and are functionally equivalent in operation, so that any channel can be configured to perform any time function. Any function can operate on the calling channel, and, under program control, on another channel determined by the program or by a parameter. The user controls the combination of time functions.

### **11.3.3 Interchannel Communication**

The autonomy of the TPU is enhanced by the ability of a channel to affect the operation of one or more other channels without CPU32 intervention. Interchannel communication can be accomplished by issuing a link service request to another channel, by controlling another channel directly, or by accessing the parameter RAM of another channel.

### **11.3.4 Programmable Channel Service Priority**

The TPU provides a programmable service priority level to each channel. Three priority levels are available. When more than one channel of a given priority requests service at the same time, arbitration is accomplished according to channel number. To prevent a single high-priority channel from permanently blocking other functions, other service requests of the same priority are performed in channel order after the lowest-numbered, highest-priority channel is serviced.

### **11.3.5 Coherency**

For data to be coherent, all available portions of the data must be identical in age, or must be logically related. As an example, consider a 32-bit counter value that is read and written as two 16-bit words. The 32-bit value is read-coherent only if both 16-bit portions are updated at the same time, and write-coherent only if both portions take

effect at the same time. Parameter RAM hardware supports coherent access of two adjacent 16-bit parameters. The host CPU must use a long-word operation to guarantee coherency.

### 11.3.6 Emulation Support

Although factory-programmed time functions can perform a wide variety of control tasks, they may not be ideal for all applications. The TPU provides emulation capability that allows the user to develop new time functions. Emulation mode is entered by setting the EMU bit in TPUMCR. In emulation mode, an auxiliary bus connection is made between TPURAM and the TPU, and access to TPURAM via the intermodule bus is disabled. A 9-bit address bus, a 32-bit data bus, and control lines transfer information between the modules. To ensure exact emulation, RAM module access timing remains consistent with access timing of the TPU microcode ROM control store.

To support changing TPU application requirements, Motorola has established a TPU function library. The function library is a collection of TPU functions written for easy assembly in combination with each other or with custom functions. Refer to Motorola Programming Note TPUPN00/D, *Using the TPU Function Library and TPU Emulation Mode* for information about developing custom functions and accessing the TPU function library. Refer to the *TPU Reference Manual* (TPURM/AD) and the Motorola TPU Literature Package (TPULITPAK/D) for more information about specific functions.

### 11.3.7 TPU Interrupts

Each of the TPU channels can generate an interrupt service request. Interrupts for each channel must be enabled by writing to the appropriate control bit in the channel interrupt enable register (CIER). The channel interrupt status register (CISR) contains one interrupt status flag per channel. Time functions set the flags. Setting a flag bit causes the TPU to make an interrupt service request if the corresponding channel interrupt enable bit is set and the interrupt request level is non-zero.

The value of the channel interrupt request level (CIRL) field in the TPU interrupt configuration register (TICR) determines the priority of all TPU interrupt service requests. CIRL values correspond to MCU interrupt request signals  $\overline{\text{IRQ}}[7:1]$ .  $\overline{\text{IRQ}}7$  is the highest-priority request signal;  $\overline{\text{IRQ}}1$  has the lowest priority. Assigning a value of %111 to CIRL causes  $\overline{\text{IRQ}}7$  to be asserted when a TPU interrupt request is made; lower field values cause corresponding lower-priority interrupt request signals to be asserted. Assigning CIRL a value of %000 disables all interrupts.

The CPU32 recognizes only interrupt requests of a priority greater than the value contained in the interrupt priority (IP) mask in the status register. When the CPU32 acknowledges an interrupt request, the priority of the acknowledged interrupt is written to the IP mask and is driven out onto the IMB address lines.

When the IP mask value driven out on the address lines is the same as the CIRL value, the TPU contends for arbitration priority. The IARB field in TPUMCR contains the TPU arbitration number. Each module that can make an interrupt service request must be assigned a unique non-zero IARB value in order to implement an arbitration scheme.

Arbitration is performed by means of serial assertion of IARB field bit values. The IARB of TPUMCR is initialized to \$0 during reset.

When the TPU wins arbitration, it must respond to the CPU32 interrupt acknowledge cycle by placing an interrupt vector number on the data bus. The vector number is used to calculate displacement into the exception vector table. Vectors are formed by concatenating the 4-bit value of the CIBV field in TICR with the 4-bit number of the channel requesting interrupt service. Since the CIBV field has a reset value of \$0, it must be assigned a value corresponding to the upper nibble of a block of 16 user-defined vector numbers before TPU interrupts are enabled. Otherwise, a TPU interrupt service request could cause the CPU32 to take one of the reserved vectors in the exception vector table.

For more information about the exception vector table, refer to **4.9 Exception Processing**. Refer to **5.8 Interrupts** for further information about interrupts.

## 11.4 A Mask Set Time Functions

The following paragraphs describe factory-programmed time functions implemented in the A mask set TPU microcode ROM. A complete description of the functions is beyond the scope of this manual. Refer to the *TPU Reference Manual* (TPURM/AD) for additional information.

### 11.4.1 Discrete Input/Output (DIO)

When a pin is used as a discrete input, a parameter indicates the current input level and the previous 15 levels of a pin. Bit 15, the most significant bit of the parameter, indicates the most recent state. Bit 14 indicates the next most recent state, and so on. The programmer can choose one of the three following conditions to update the parameter: 1) when a transition occurs, 2) when the CPU32 makes a request, or 3) when a rate specified in another parameter is matched. When a pin is used as a discrete output, it is set high or low only upon request by the CPU32.

Refer to TPU programming note *Discrete Input/Output (DIO) TPU Function* (TPUPN18/D) for more information.

### 11.4.2 Input Capture/Input Transition Counter (ITC)

Any channel of the TPU can capture the value of a specified TCR upon the occurrence of each transition or specified number of transitions and then generate an interrupt request to notify the CPU32. A channel can perform input captures continually, or a channel can detect a single transition or specified number of transitions, then cease channel activity until reinitialization. After each transition or specified number of transitions, the channel can generate a link to a sequential block of up to eight channels. The user specifies a starting channel of the block and the number of channels within the block. The generation of links depends on the mode of operation. In addition, after each transition or specified number of transitions, one byte of the parameter RAM (at an address specified by channel parameter) can be incremented and used as a flag to notify another channel of a transition.



Refer to TPU programming note *Input Capture/Input Transition Counter (ITC) TPU Function* (TPUPN16/D) for more information.

### 11.4.3 Output Compare (OC)

The output compare function generates a rising edge, a falling edge, or a toggle of the previous edge in one of three ways:

1. Immediately upon CPU32 initiation, thereby generating a pulse with a length equal to a programmable delay time.
2. At a programmable delay time from a user-specified time.
3. As a continuous square wave. Upon receiving a link from a channel, OC references, without CPU32 interaction, a specifiable period and calculates an offset:

$$\text{OFFSET} = \text{PERIOD} \cdot \text{RATIO}$$

where “RATIO” is a parameter supplied by the user.

This algorithm generates a 50% duty-cycle continuous square wave with each high/low time equal to the calculated offset. Due to offset calculation, there is an initial link time before continuous pulse generation begins.

Refer to TPU programming note *Output Compare (OC) TPU Function* (TPUPN12/D) for more information.

### 11.4.4 Pulse-Width Modulation (PWM)

The TPU can generate a pulse-width modulated waveform with any duty cycle from zero to 100% (within the resolution and latency capability of the TPU). To define the PWM, the CPU32 provides one parameter that indicates the period and another parameter that indicates the high time. Updates to one or both of these parameters can direct the waveform change to take effect immediately, or coherently beginning at the next low-to-high transition of the pin.

Refer to TPU programming note *Pulse-Width Modulation (PWM) TPU Function* (TPUPN17/D) for more information.

### 11.4.5 Synchronized Pulse-Width Modulation (SPWM)

The TPU generates a PWM waveform in which the CPU32 can change the period and/or high time at any time. When synchronized to a time function on a second channel, the synchronized PWM low-to-high transitions have a time relationship to transitions on the second channel.

Refer to TPU programming note *Synchronized Pulse-Width Modulation (SPWM) TPU Function* (TPUPN19/D) for more information.

#### 11.4.6 Period Measurement with Additional Transition Detect (PMA)

This function and the following function are used primarily in toothed-wheel speed-sensing applications, such as monitoring rotational speed of an engine. The period measurement with additional transition detect function allows for a special-purpose 23-bit period measurement. It can detect the occurrence of an additional transition (caused by an extra tooth on the sensed wheel) indicated by a period measurement that is less than a programmable ratio of the previous period measurement.

Once detected, this condition can be counted and compared to a programmable number of additional transitions detected before TCR2 is reset to \$FFFF. Alternatively, a byte at an address specified by a channel parameter can be read and used as a flag. A non-zero value of the flag indicates that TCR2 is to be reset to \$FFFF once the next additional transition is detected.

Refer to TPU programming note *Period Measurement, Additional Transition Detect (PMA) TPU Function* (TPUPN15A/D) for more information.

#### 11.4.7 Period Measurement with Missing Transition Detect (PMM)

Period measurement with missing transition detect allows a special-purpose 23-bit period measurement. It detects the occurrence of a missing transition (caused by a missing tooth on the sensed wheel), indicated by a period measurement that is greater than a programmable ratio of the previous period measurement. Once detected, this condition can be counted and compared to a programmable number of additional transitions detected before TCR2 is reset to \$FFFF. In addition, one byte at an address specified by a channel parameter can be read and used as a flag. A non-zero value of the flag indicates that TCR2 is to be reset to \$FFFF once the next missing transition is detected.

Refer to TPU programming note *Period Measurement, Missing Transition Detect (PMM) TPU Function* (TPUPN15B/D) for more information.

#### 11.4.8 Position-Synchronized Pulse Generator (PSP)

Any channel of the TPU can generate an output transition or pulse, which is a projection in time based on a reference period previously calculated on another channel. Both TCRs are used in this algorithm: TCR1 is internally clocked, and TCR2 is clocked by a position indicator in the user's device. An example of a TCR2 clock source is a sensor that detects special teeth on the flywheel of an automobile using PMA or PMM. The teeth are placed at known degrees of engine rotation; hence, TCR2 is a coarse representation of engine degrees. For example, each count represents some number of degrees.

Up to 15 position-synchronized pulse generator function channels can operate with a single input reference channel executing a PMA or PMM input function. The input channel measures and stores the time period between the flywheel teeth and resets TCR2 when the engine reaches a reference position. The output channel uses the period calculated by the input channel to project output transitions at specific engine degrees. Because the flywheel teeth might be 30 or more degrees apart, a fractional

multiplication operation resolves down to the desired degrees. Two modes of operation allow pulse length to be determined either by angular position or by time.

Refer to TPU programming note *Position-Synchronized Pulse Generator (PSP) TPU Function* (TPUPN14/D) for more information.

#### 11.4.9 Stepper Motor (SM)

The stepper motor control algorithm provides for linear acceleration and deceleration control of a stepper motor with a programmable number of step rates of up to 14. Any group of channels, up to eight, can be programmed to generate the control logic necessary to drive a stepper motor.

The time period between steps (P) is defined as:

$$P(r) = K1 - K2 \cdot r$$

where r is the current step rate (1–14), and K1 and K2 are supplied as parameters.

After providing the desired step position in a 16-bit parameter, the CPU32 issues a step request. Next, the TPU steps the motor to the desired position through an acceleration/deceleration profile defined by parameters. The parameter indicating the desired position can be changed by the CPU32 while the TPU is stepping the motor. This algorithm changes the control state every time a new step command is received.

A 16-bit parameter initialized by the CPU32 for each channel defines the output state of the associated pin. The bit pattern written by the CPU32 defines the method of stepping, such as full stepping or half stepping. With each transition, the 16-bit parameter rotates one bit. The period of each transition is defined by the programmed step rate.

Refer to TPU programming note *Stepper Motor (SM) TPU Function* (TPUPN13/D) for more information.

#### 11.4.10 Period/Pulse-Width Accumulator (PPWA)

The period/pulse-width accumulator algorithm accumulates a 16-bit or 24-bit sum of either the period or the pulse width of an input signal over a programmable number of periods or pulses (from one to 255). After an accumulation period, the algorithm can generate a link to a sequential block of up to eight channels. The user specifies a starting channel of the block and number of channels within the block. Generation of links depends on the mode of operation. Any channel can be used to measure an accumulated number of periods of an input signal. A maximum of 24 bits can be used for the accumulation parameter. From one to 255 period measurements can be made and summed with the previous measurement(s) before the TPU interrupts the CPU, allowing instantaneous or average frequency measurement, and the latest complete accumulation (over the programmed number of periods).

The pulse width (high-time portion) of an input signal can be measured (up to 24 bits) and added to a previous measurement over a programmable number of periods (one

to 255). This provides an instantaneous or average pulse-width measurement capability, allowing the latest complete accumulation (over the specified number of periods) to always be available in a parameter. By using the output compare function in conjunction with PPWA, an output signal can be generated that is proportional to a specified input signal. The ratio of the input and output frequency is programmable. One or more output signals with different frequencies, yet proportional and synchronized to a single input signal, can be generated on separate channels.

Refer to TPU programming note *Period/Pulse-Width Accumulator (PPWA) TPU Function* (TPUPN11/D) for more information.

#### **11.4.11 Quadrature Decode (QDEC)**

The quadrature decode function uses two channels to decode a pair of out-of-phase signals in order to present the CPU32 with directional information and a position value. It is particularly suitable for use with slotted encoders employed in motor control. The function derives full resolution from the encoder signals and provides a 16-bit position counter with rollover/under indication via an interrupt.

The counter in parameter RAM is updated when a valid transition is detected on either one of the two inputs. The counter is incremented or decremented depending on the lead/lag relationship of the two signals at the time of servicing the transition. The user can read or write the counter at any time. The counter is free running, overflowing to \$0000 or underflowing to \$FFFF depending on direction.

The QDEC function also provides a time stamp referenced to TCR1 for every valid signal edge and the ability for the host CPU to obtain the latest TCR1 value. This feature allows position interpolation by the host CPU between counts at very slow count rates.

Refer to TPU programming note *Quadrature Decode (QDEC) TPU Function* (TPUPN20/D) for more information.

### **11.5 G Mask Set Time Functions**

The following paragraphs describe factory-programmed time functions implemented in the motion control microcode ROM. A complete description of the functions is beyond the scope of this manual.

Refer to the *TPU Reference Manual* (TPURM/AD) for additional information.

#### **11.5.1 Table Stepper Motor (TSM)**

The TSM function provides for acceleration and deceleration control of a stepper motor with a programmable number of step rates up to 58. TSM uses a table in parameter RAM, rather than an algorithm, to define the stepper motor acceleration profile, allowing the user to fully define the profile. In addition, a slew rate parameter allows fine control of the terminal running speed of the motor independent of the acceleration table. The CPU need only write a desired position, and the TPU accelerates, slews, and decelerates the motor to the required position. Full and half step support is provided for two-phase motors. In addition, a slew rate parameter allows fine control of the terminal running speed of the motor independent of the acceleration table.

Refer to TPU programming note *Table Stepper Motor (TSM) TPU Function* (TPUPN04/D) for more information.

### **11.5.2 New Input Capture/Transition Counter (NITC)**

Any channel of the TPU can capture the value of a specified TCR or any specified location in parameter RAM upon the occurrence of each transition or specified number of transitions, and then generate an interrupt request to notify the CPU32. The times of the most recent two transitions are maintained in parameter RAM. A channel can perform input captures continually, or a channel can detect a single transition or specified number of transitions, ceasing channel activity until reinitialization. After each transition or specified number of transitions, the channel can generate a link to other channels.

Refer to TPU programming note *New Input Capture/Transition Counter (NITC) TPU Function* (TPUPN08/D) for more information.

### **11.5.3 Queued Output Match (QOM)**

QOM can generate single or multiple output match events from a table of offsets in parameter RAM. Loop modes allow complex pulse trains to be generated once, a specified number of times, or continuously. The function can be triggered by a link from another TPU channel. In addition, the reference time for the sequence of matches can be obtained from another channel. QOM can generate pulse width modulated waveforms, including waveforms with high times of 0% or 100%. QOM also allows a TPU channel to be used as a discrete output pin.

Refer to TPU programming note *Queued Output Match (QOM) TPU Function* (TPUPN01/D) for more information.

### **11.5.4 Programmable Time Accumulator (PTA)**

PTA accumulates a 32-bit sum of the total high time, low time, or period of an input signal over a programmable number of periods or pulses. The accumulation can start on a rising or falling edge. After the specified number of periods or pulses, PTA generates an interrupt request and optionally generates links to other channels.

From one to 255 period measurements can be made and summed with the previous measurement(s) before the TPU interrupts the CPU32, providing instantaneous or average frequency measurement capability, and the latest complete accumulation (over the programmed number of periods).

Refer to TPU programming note *Programmable Time Accumulator (PTA) TPU Function* (TPUPN06/D) for more information.

### **11.5.5 Multichannel Pulse-Width Modulation (MCPWM)**

MCPWM generates pulse-width modulated outputs with full 0% to 100% duty cycle range independent of other TPU activity. This capability requires two TPU channels plus an external gate for one PWM channel. (A simple one-channel PWM capability is supported by the QOM function.)

Multiple PWMs generated by MCPWM have two types of high time alignment: edge aligned and center aligned. Edge aligned mode uses  $n + 1$  TPU channels for  $n$  PWMs; center aligned mode uses  $2n + 1$  channels. Center aligned mode allows a user-defined “dead time” to be specified so that two PWMs can be used to drive an H-bridge without destructive current spikes. This feature is important for motor control applications.

Refer to TPU programming note *Multichannel Pulse-Width Modulation (MCPWM) TPU Function* (TPUPN05/D) for more information.

#### **11.5.6 Fast Quadrature Decode (FQD)**

FQD is a position feedback function for motor control. It decodes the two signals from a slotted encoder to provide the CPU32 with a 16-bit free running position counter. FQD incorporates a “speed switch” which disables one of the channels at high speed, allowing faster signals to be decoded. A time stamp is provided on every counter update to allow position interpolation and better velocity determination at low speed or when low resolution encoders are used. The third index channel provided by some encoders is handled by the NITC function.

Refer to TPU programming note *Fast Quadrature Decode (FQD) TPU Function* (TPUPN02/D) for more information.

#### **11.5.7 Universal Asynchronous Receiver/Transmitter (UART)**

The UART function uses one or two TPU channels to provide asynchronous serial communication. Data word length is programmable from one to 14 bits. The function supports detection or generation of even, odd, and no parity. Baud rate is freely programmable and can be higher than 100 Kbaud. Eight bidirectional UART channels running in excess of 9600 baud can be implemented.

Refer to TPU programming note *Universal Asynchronous Receiver/Transmitter (UART) TPU Function* (TPUPN07/D) for more information.

#### **11.5.8 Brushless Motor Commutation (COMM)**

This function generates the phase commutation signals for a variety of brushless motors, including three-phase brushless DC motors. It derives the commutation state directly from the position decoded in FQD, thus eliminating the need for hall effect sensors.

The state sequence is implemented as a user-configurable state machine, thus providing a flexible approach with other general applications. An offset parameter is provided to allow all the switching angles to be advanced or retarded on the fly by the CPU32. This feature is useful for torque maintenance at high speeds.

Refer to TPU programming note *Brushless Motor Commutation (COMM) TPU Function* (TPUPN09/D) for more information.

### 11.5.9 Frequency Measurement (FQM)

FQM counts the number of input pulses to a TPU channel during a user-defined window period. The function has single shot and continuous modes. No pulses are lost between sample windows in continuous mode. The user selects whether to detect pulses on the rising or falling edge. This function is intended for high speed measurement; measurement of slow pulses with noise rejection can be made with PTA.

Refer to TPU programming note *Frequency Measurement (FQM) TPU Function* (TPUPN03/D) for more information.

### 11.5.10 Hall Effect Decode (HALLD)

This function decodes the sensor signals from a brushless motor, along with a direction input from the CPU32, into a state number. The function supports two- or three-sensor decoding. The decoded state number is written into a COMM channel, which outputs the required commutation drive signals. In addition to brushless motor applications, the function can have more general applications, such as decoding option switches.

Refer to TPU programming note *Hall Effect Decode (HALLD) TPU Function* (TPUPN10/D) for more information.

## 11.6 Host Interface Registers

The TPU memory map contains three groups of registers:

- System configuration registers
- Channel control and status registers
- Development support and test verification registers

All registers except the channel interrupt status register (CISR) must be read or written by means of word accesses. The address space of the TPU memory map occupies 512 bytes. Unused registers within the 512-byte address space return zeros when read.

### 11.6.1 System Configuration Registers

The TPU configuration control registers, TPUMCR and TICR, determine the value of the prescaler, perform emulation control, specify whether the external TCR2 pin functions as a clock source or as gate of the DIV8 clock for TCR2, and determine interrupt request level and interrupt vector number assignment. Refer to **D.8.1 TPU Module Configuration Register** and **D.8.5 TPU Interrupt Configuration Register** for more information about TPUMCR and TICR.

#### 11.6.1.1 Prescaler Control for TCR1

Timer count register one (TCR1) is clocked from the output of a prescaler. Two fields in TPUMCR control TCR1. The prescaler's input is the internal TPU system clock divided by either 4 or 32, depending on the value of the PSCK bit. The prescaler divides this input by 1, 2, 4, or 8, depending on the value of TCR1P. Channels using

TCR1 have the capability to resolve down to the TPU system clock divided by 4. Refer to **Figure 11-2** and **Table 11-1**.

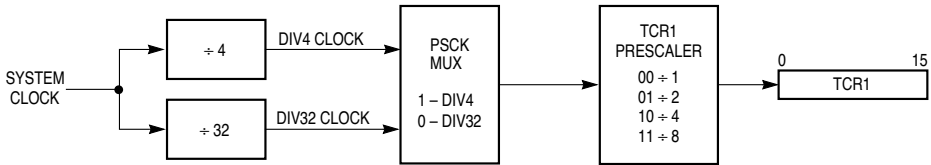

TPU PRE BLOCK 1

**Figure 11-2 TCR1 Prescaler Control**

**Table 11-1 TCR1 Prescaler Control**

TCR1 Prescaler	Divide By	PSCK = 0		PSCK = 1	
		Number of Clocks	Rate at 20.97 MHz	Number of Clocks	Rate at 20.97 MHz
00	1	32	1.6 $\mu$ s	4	200 ns
01	2	64	3.2 $\mu$ s	8	400 ns
10	4	128	6.4 $\mu$ s	16	0.8 $\mu$ s
11	8	256	12.8 $\mu$ s	32	1.6 $\mu$ s

### 11.6.1.2 Prescaler Control for TCR2

Timer count register two (TCR2), like TCR1, is clocked from the output of a prescaler. The T2CG bit in TPUMCR determines whether the T2CLK pin functions as an external clock source for TCR2 or as the gate in the use of TCR2 as a gated pulse accumulator. The function of the T2CG bit is shown in **Figure 11-3**.

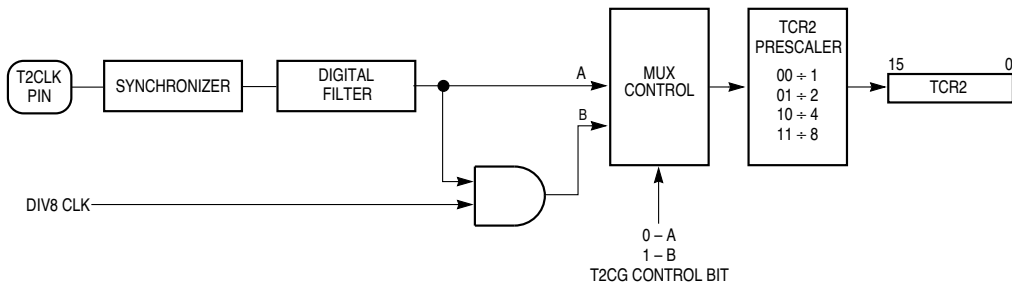

TPU PRE BLOCK 2

**Figure 11-3 TCR2 Prescaler Control**



When T2CG is set, the external TCR2 pin functions as a gate of the DIV8 clock (the TPU system clock divided by eight). In this case, when the external TCR2 pin is low, the DIV8 clock is blocked, preventing it from incrementing TCR2. When the external TCR2 pin is high, TCR2 is incremented at the frequency of the DIV8 clock. When T2CG is cleared, an external clock from the TCR2 pin, which has been synchronized and fed through a digital filter, increments TCR2.

The TCR2 field in TPUMCR specifies the value of the prescaler: 1, 2, 4, or 8. Channels using TCR2 have the capability to resolve down to the TPU system clock divided by eight. **Table 11-2** is a summary of prescaler output.

**Table 11-2 TCR2 Prescaler Control**

TCR2 Prescaler	Divide By	Internal Clock Divided By	External Clock Divided By
00	1	8	1
01	2	16	2
10	4	32	4
11	8	64	8

### 11.6.1.3 Emulation Control

Asserting the EMU bit in TPUMCR places the TPU in emulation mode. In emulation mode, the TPU executes microinstructions from TPURAM exclusively. Access to the TPURAM module through the IMB is blocked, and the TPURAM module is dedicated for use by the TPU. After reset, EMU can be written only once.

### 11.6.1.4 Low-Power Stop Control

If the STOP bit in TPUMCR is set, the TPU shuts down its internal clocks, shutting down the internal microengine. TCR1 and TCR2 cease to increment and retain the last value before the stop condition was entered. The TPU asserts the stop flag (STF) in TPUMCR to indicate that it has stopped.

## 11.6.2 Channel Control Registers

The channel control and status registers enable the TPU to control channel interrupts, assign time functions to be executed on a specified channel, or select the mode of operation or the type of host service request for the time function specified. Refer to **Table 11-4**.

### 11.6.2.1 Channel Interrupt Enable and Status Registers

The channel interrupt enable register (CIER) allows the CPU32 to enable or disable the ability of individual TPU channels to request interrupt service. Setting the appropriate bit in the register enables a channel to make an interrupt service request; clearing a bit disables the interrupt.

The channel interrupt status register (CISR) contains one interrupt status flag per channel. Time functions specify via microcode when an interrupt flag is set. Setting a flag causes the TPU to make an interrupt service request if the corresponding CIER

bit is set and the CIRL field has a non-zero value. To clear a status flag, read CISR, then write a zero to the appropriate bit. CISR is the only TPU register that can be accessed on a byte basis.

### 11.6.2.2 Channel Function Select Registers

Encoded 4-bit fields within the channel function select registers specify one of 16 time functions to be executed on the corresponding channel. Encodings for predefined functions in the TPU ROM are found in **Table 11-3**.

**Table 11-3 TPU Function Encodings**

A Mask Set		G Mask Set	
Function Name	Function Code	Function Name	Function Code
PPWA Period/pulse width accumulator	\$F	PTA Programmable time accumulator	\$F
OC Output compare	\$E	QOM Queued output match	\$E
SM Stepper motor	\$D	TSM Table stepper motor	\$D
PSP Position-synchronized pulse generator	\$C	FQM Frequency measurement	\$C
PMA/PMM Period measurement with additional/missing transition detect	\$B	UART Universal asynchronous receiver/transmitter	\$B
ITC Input capture/input transition counter	\$A	NITC New input transition counter	\$A
PWM Pulse width modulation	\$9	COMM Multiphase motor commutation	\$9
DIO Discrete input/output	\$8	HALLD Hall effect decode	\$8
SPWM Synchronized pulse width modulation	\$7	—	—
QDEC Quadrature decode	\$6	—	—

### 11.6.2.3 Host Sequence Registers

The host sequence field selects the mode of operation for the time function selected on a given channel. The meaning of the host sequence bits depends on the time function specified. Refer to **Table 11-4**, which is a summary of the host sequence and host service request bits for each time function. Refer to the *TPU Reference Manual* (TPURM/AD) and the Motorola TPU Literature Package (TPULITPAK/D) for more information.

#### 11.6.2.4 Host Service Registers

The host service request field selects the type of host service request for the time function selected on a given channel. The meaning of the host service request bits is determined by time function microcode. Refer to the *TPU Reference Manual (TPURM/AD)* and the Motorola TPU Literature Package (TPULITPAK/D) for more information.

A host service request field of %00 signals the CPU that service is completed and that there are no further pending host service requests. The host can request service on a channel by writing the corresponding host service request field to one of three non-zero states. It is imperative for the CPU to monitor the host service request register and wait until the TPU clears the service request for a channel before changing any parameters or issuing a new service request to the channel.

#### 11.6.2.5 Channel Priority Registers

The channel priority registers (CPR1, CPR2) assign one of three priority levels to a channel or disable the channel. **Table 11-4** indicates the number of time slots guaranteed for each channel priority encoding.

**Table 11-4 Channel Priority Encodings**

CHX[1:0]	Service	Guaranteed Time Slots
00	Disabled	—
01	Low	1 out of 7
10	Middle	2 out of 7
11	High	4 out of 7

#### 11.6.3 Development Support and Test Registers

These registers are used for custom microcode development or for factory test. Describing the use of these registers is beyond the scope of this manual. Register descriptions are provided in **D.8 Time Processor Unit (TPU)**. Refer to the *TPU Reference Manual (TPURM/AD)* for more information.



## SECTION 12 STANDBY RAM WITH TPU EMULATION

The standby RAM module with TPU emulation capability (TPURAM) consists of a control register block and a 3.5-Kbyte array of fast (two system clock) static RAM, which is especially useful for system stacks and variable storage. The TPURAM responds to both program and data space accesses. The TPURAM can also be used to emulate TPU microcode ROM.

### 12.1 General

The TPURAM can be mapped to the lower 3.5 Kbytes of any 4-Kbyte boundary in the address map, but must not overlap the module control registers as overlap makes the registers inaccessible. Data can be read or written in bytes, words or long words. The TPURAM is powered by  $V_{DD}$  in normal operation. During power-down, TPURAM contents can be maintained by power from the  $V_{STBY}$  input. Power switching between sources is automatic.

### 12.2 TPURAM Register Block

There are three TPURAM control registers: the TPURAM module configuration register (TRAMMCR), the TPURAM test register (TRAMTST), and the TPURAM base address and status register (TRAMBAR). To protect these registers from accidental modification, they are always mapped to supervisor data space.

The TPURAM control register block begins at address  $\$7FFB00$  or  $\$FFFB00$ , depending on the value of the module mapping (MM) bit in the SIM configuration register (SIMCR). Refer to **5.2.1 Module Mapping** for more information on how the state of MM affects the system.

The TPURAM control register block occupies eight bytes of address space. Unimplemented register addresses are read as zeros, and writes have no effect. Refer to **D.9 Standby RAM Module with TPU Emulation Capability (TPURAM)** for register block address map and register bit/field definitions.

### 12.3 TPURAM Array Address Mapping

The base address and status register TRAMBAR specifies the TPURAM array base address in the MCU memory map. TRAMBAR[15:4] specify the 12 high-order bits of the base address. The TPU bus interface unit compares these bits to address lines ADDR[23:12]. If the two match, then the low order address lines and the SIZ[1:0] signals are used to access the RAM location in the array.

The RAM disable (RAMDS) bit, the LSB of TRAMBAR, indicates whether the TPURAM array is active (RAMDS = 0) or disabled (RAMDS = 1). The array is disabled coming out of reset and remains disabled if the base address field is programmed with an address that overlaps the address of the module control register block. Writing a valid base address to TRAMBAR[15:4] clears RAMDS and enables the array.

TRAMBAR can be written only once after a reset. This prevents runaway software from accidentally re-mapping the array. Because the locking mechanism is activated by the first write after a reset, the base address field should be written in a single word operation. Writing only one-half of the register prevents the other half from being written.

## 12.4 TPURAM Privilege Level

The RASP field in TRAMMCR specifies whether access to the TPURAM can be made from supervisor mode only, or from either user or supervisor mode. If supervisor-only access is specified, an access from user mode is ignored by the TPURAM control logic and can be decoded externally. Refer to **4.7 Privilege Levels** and **5.5.1.7 Function Codes** for more information concerning privilege levels.

## 12.5 Normal Operation

During normal operation, the TPURAM control registers and array can be accessed by the CPU32, by byte, word, or long word. A byte or aligned word access takes one bus cycle (two system clock cycles). A long word access requires two bus cycles. Misaligned accesses are not permitted by the CPU32 and will result in an address error exception. Refer to **5.6 Bus Operation** for more information concerning access times. The TPU cannot access the array and has no effect on the operation of the TPURAM during normal operation.

## 12.6 Standby Operation

Standby mode maintains the RAM array when the MCU main power supply is turned off.

Relative voltage levels of the  $V_{DD}$  and  $V_{STBY}$  pins determine whether the TPURAM is in standby mode. TPURAM circuitry switches to the standby power source when specified limits are exceeded. The TPURAM is essentially powered by the power supply pin with the greatest voltage (for example,  $V_{DD}$  or  $V_{STBY}$ ). If specified standby supply voltage levels are maintained during the transition, there is no loss of memory when switching occurs. The RAM array cannot be accessed while the TPURAM is powered from  $V_{STBY}$ . If standby operation is not desired, connect the  $V_{STBY}$  pin to the  $V_{SS}$  pin.

$I_{SB}$  (SRAM standby current) may exceed specified maximum standby current during the time  $V_{DD}$  makes the transition from normal operating level to the level specified for standby operation. This occurs within the voltage range  $V_{SB} - 0.5 \text{ V} \geq V_{DD} \geq V_{SS} + 0.5 \text{ V}$ . Typically,  $I_{SB}$  peaks when  $V_{DD} \approx V_{SB} - 1.5 \text{ V}$ , and averages 1.0 mA over the transition period.

Refer to **APPENDIX A ELECTRICAL CHARACTERISTICS** for standby switching and power consumption specifications.

## 12.7 Low-Power Stop Operation

Setting the STOP bit in TRAMMCR places the TPURAM in low-power stop mode. In low-power stop mode, the array retains its contents, but cannot be read or written by the CPU32. STOP can be written only when the processor is operating in supervisor mode. STOP is set during resets. Low-power stop mode is exited by clearing STOP.

The TPURAM module will switch to standby mode while it is in low-power mode, provided the operating constraints discussed above are met.

## 12.8 Reset

Reset places the TPURAM in low-power stop mode, enables supervisor mode access only, clears the base address register, and disables the array. These actions make it possible to write a new base address into the base address register.

When a synchronous reset occurs while a byte or word TPURAM access is in progress, the access is completed. If reset occurs during the first word access of a long-word operation, only the first word access is completed. If reset occurs during the second word access of a long-word operation, the entire access is completed. Data being read from or written to the TPURAM may be corrupted by asynchronous reset. Refer to **5.7 Reset** for more information concerning resets.

## 12.9 TPU Microcode Emulation

The TPURAM array can emulate the microcode ROM in the TPU module. This provides a means for developing custom TPU code. The TPU selects TPU emulation mode.

The TPU is connected to the TPURAM via a dedicated bus. While the TPURAM array is in TPU emulation mode, the access timing of the TPURAM module matches the timing of the TPU microcode ROM to ensure accurate emulation. Normal accesses through the IMB are inhibited and the control registers have no effect, allowing external RAM to emulate the TPURAM at the same addresses. Refer to **SECTION 11 TIME PROCESSOR UNIT** and to the *TPU Reference Manual* (TPURM/AD) for more information.





## SECTION 13 CAN 2.0B CONTROLLER MODULE (TouCAN)

This section is an overview of the TouCAN module. Refer to **D.10 TouCAN Module** for information concerning TouCAN address map and register structure.

### 13.1 General

The TouCAN module is a communication controller that implements the controller area network (CAN) protocol, an asynchronous communications protocol used in automotive and industrial control systems. It is a high speed (1 Mbit/sec), short distance, priority based protocol which can communicate using a variety of mediums (for example, fiber optic cable or an unshielded twisted pair of wires). The TouCAN supports both the standard and extended identifier (ID) message formats specified in the CAN protocol specification, revision 2.0, part B.

The TouCAN module contains 16 message buffers, which are used for transmit and receive functions. It also contains message filters, which are used to qualify the received message IDs when comparing them to the receive buffer identifiers.

**Figure 13-1** shows a block diagram of the TouCAN.

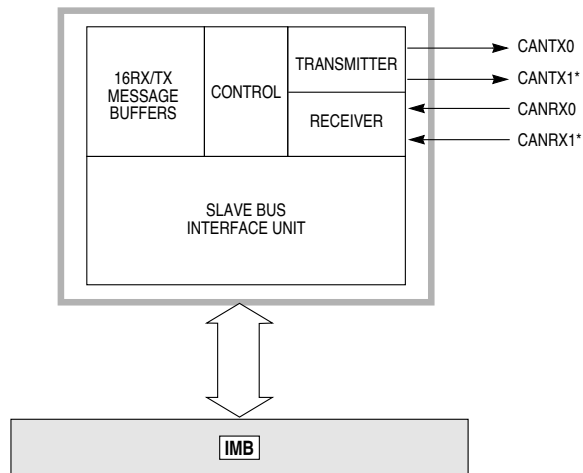

\* THESE PINS ARE NOT BONDED ON THE MC68376

TOUCAN BLOCK

**Figure 13-1 TouCAN Block Diagram**

## 13.2 External Pins

The TouCAN module interface to the CAN bus is composed of four pins: CANTX0 and CANTX1, which transmit serial data, and CANRX0 and CANRX1, which receive serial data. **Figure 13-2** shows a typical CAN system.

### NOTE

Pins CANTX1 and CANRX1 are not used on the MC68376.

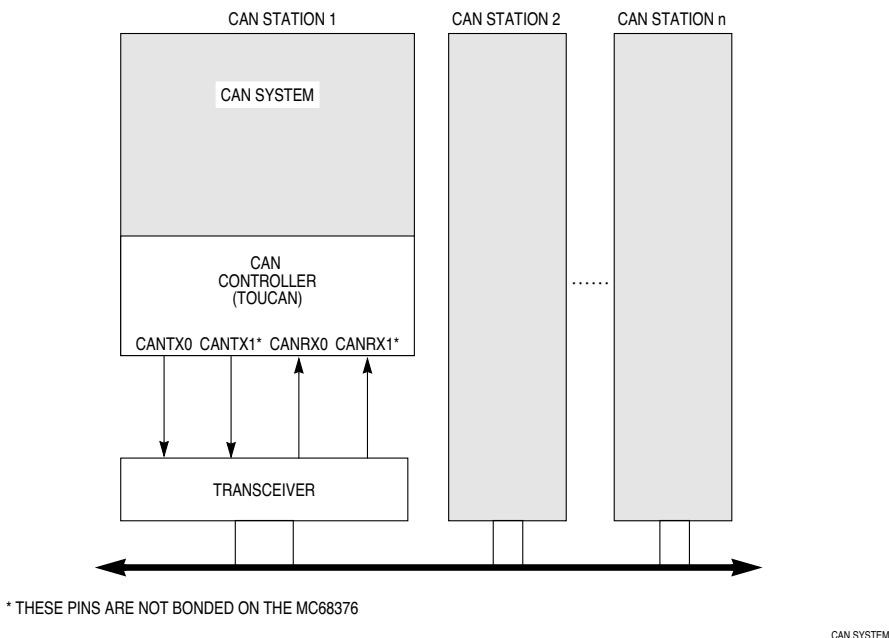

**Figure 13-2 Typical CAN Network**

Each CAN station is connected physically to the CAN bus through a transceiver. The transceiver provides the transmit drive, waveshaping, and receive/compare functions required for communicating on the CAN bus. It can also provide protection against damage to the TouCAN caused by a defective CAN bus or a defective CAN station.

## 13.3 Programmer's Model

The TouCAN module address space is split into 128 bytes starting at the base address, and then an extra 256 bytes starting at the base address +128. The upper 256 are fully used for the message buffer structures. Out of the lower 128 bytes, only part is occupied by various registers. Refer to **D.10 TouCAN Module** for detailed information on the TouCAN address map and register structure.

## NOTE

The TouCAN has no hard-wired protection against invalid bit/field programming within its registers. Specifically, no protection is provided if the programming does not meet CAN protocol requirements.

Programming the TouCAN control registers is typically done during system initialization, prior to the TouCAN becoming synchronized with the CAN bus. The configuration registers can be changed after synchronization by halting the TouCAN module. This is done when the user sets the HALT bit in the TouCAN module configuration register (CANMCR). The TouCAN responds by asserting the CANMCR NOTRDY bit. Additionally, the control registers can be modified while the MCU is in background debug mode.

### 13.4 TouCAN Architecture

The TouCAN module utilizes a flexible design which allows each of its 16 message buffers to be assigned either as a transmit (TX) buffer or a receive (RX) buffer. In addition, to reduce the CPU32 overhead required for message handling each message buffer is assigned an interrupt flag bit to indicate successful completion of transmission or reception, respectively.

#### 13.4.1 TX/RX Message Buffer Structure

**Figure 13-3** displays the extended (29 bit) ID message buffer structure. **Figure 13-4** displays the standard (11 bit) ID message buffer structure.

	15	8	7	4	3	0	
\$0	TIME STAMP		CODE		LENGTH		CONTROL/STATUS
\$2	ID[28:18]		SRR	IDE	ID[17:15]		ID_HIGH
\$4	ID[14:0]				RTR		ID_LOW
\$6	DATA BYTE 0		DATA BYTE 1				
\$8	DATA BYTE 2		DATA BYTE 3				
\$A	DATA BYTE 4		DATA BYTE 5				
\$C	DATA BYTE 6		DATA BYTE 7				
\$E	RESERVED						

**Figure 13-3 Extended ID Message Buffer Structure**

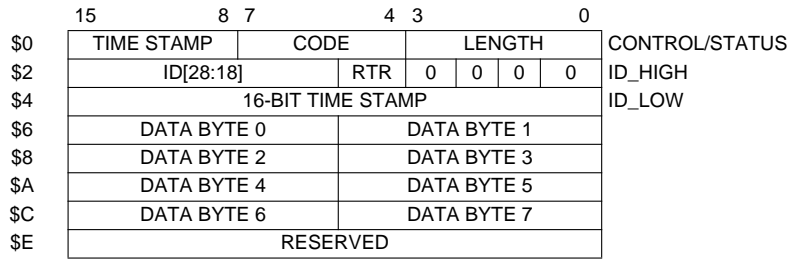

**Figure 13-4 Standard ID Message Buffer Structure**

### 13.4.1.1 Common Fields for Extended and Standard Format Frames

**Table 13-1** describes the message buffer fields that are common to both extended and standard identifier format frames.

**Table 13-1 Common Extended/Standard Format Frames**

Field	Description
Time Stamp	Contains a copy of the high byte of the free running timer, which is captured at the beginning of the identifier field of the frame on the CAN bus.
Code	Refer to <b>Tables 13-2</b> and <b>13-3</b>
RX Length	Length (in bytes) of the RX data stored in offset \$6 through \$D of the buffer. This field is written by the TouCAN module, copied from the DLC (data length code) field of the received frame.
TX Length	Length (in bytes) of the data to be transmitted, located in offset \$6 through \$D of the buffer. This field is written by the CPU32, and is used as the DLC field value. If RTR (remote transmission request) = 1, the frame is a remote frame and will be transmitted without data field, regardless of the value in TX length.
Data	This field can store up to eight data bytes for a frame. For RX frames, the data is stored as it is received from the bus. For TX frames, the CPU32 provides the data to be transmitted within the frame.
Reserved	This word entry field (16 bits) should not be accessed by the CPU32.

**Table 13-2 Message Buffer Codes for Receive Buffers**

RX Code Before RX New Frame	Description	RX Code After RX New Frame	Comment
0000	NOT ACTIVE — message buffer is not active.	—	—
0100	EMPTY — message buffer is active and empty.	0010	—
0010	FULL — message buffer is full.	0110	If a CPU32 read occurs before the new frame, new receive code is 0010.
0110	OVERRUN — second frame was received into a full buffer before the CPU read the first one.		
0XY1 <sup>1</sup>	BUSY — message buffer is now being filled with a new receive frame. This condition will be cleared within 20 cycles.	0010	An empty buffer was filled (XY was 10).
		0110	A full/overflow buffer was filled (Y was 1).

**NOTES:**

1. For TX message buffers, upon read, the BUSY bit should be ignored.

**Table 13-3 Message Buffer Codes for Transmit Buffers**

RTR	Initial TX Code	Description	Code After Successful Transmission
X	1000	Message buffer not ready for transmit.	—
0	1100	Data frame to be transmitted once, unconditionally.	1000
1	1100	Remote frame to be transmitted once, and message buffer becomes an RX message buffer for data frames.	0100
0	1010 <sup>1</sup>	Data frame to be transmitted only as a response to a remote frame, always.	1010
0	1110	Data frame to be transmitted only once, unconditionally, and then only as a response to remote frame, always.	1010

NOTES:

1. When a matching remote request frame is detected, the code for such a message buffer is changed to be 1110.

### 13.4.1.2 Fields for Extended Format Frames

**Table 13-4** describes the message buffer fields used only for extended identifier format frames.

**Table 13-4 Extended Format Frames**

Field	Description
ID[28:18]/[17:15]	Contains the 14 most significant bits of the extended identifier, located in the ID HIGH word of the message buffer.
Substitute Remote Request (SRR)	Contains a fixed recessive bit, used only in extended format. Should be set to one by the user for TX buffers. It will be stored as received on the CAN bus for RX buffers.
ID Extended (IDE)	If extended format frame is used, this field should be set to one. If zero, standard format frame should be used.
ID[14:0]	Bits [14:0] of the extended identifier, located in the ID LOW word of the message buffer.
Remote Transmission Request (RTR)	This bit is located in the least significant bit of the ID LOW word of the message buffer; 0 = Data Frame, 1 = Remote Frame.

### 13.4.1.3 Fields for Standard Format Frames

**Table 13-5** describes the message buffer fields used only for standard identifier format frames.

**Table 13-5 Standard Format Frames**

Field	Description
16-Bit Time Stamp	The ID LOW word, which is not needed for standard format, is used in a standard format buffer to store the 16-bit value of the free-running timer which is captured at the beginning of the identifier field of the frame on the CAN bus.
ID[28:18]	Contains bits [28:18] of the identifier, located in the ID HIGH word of the message buffer. The four least significant bits in this register (corresponding to the IDE bit and ID[17:15] for an extended identifier message) must all be written as logic zeros to ensure proper operation of the TouCAN.
RTR	This bit is located in the ID HIGH word of the message buffer; 0 = data frame, 1 = remote frame.
RTR/SRR Bit Treatment	If the TouCAN transmits this bit as a one and receives it as a zero, an "arbitration loss" is indicated. If the TouCAN transmits this bit as a zero and is receives it as a one, a bit error is indicated. If the TouCAN transmits a value and receives a matching response, a successful bit transmission is indicated.

#### 13.4.1.4 Serial Message Buffers

To allow double buffering of messages, the TouCAN has two shadow buffers called serial message buffers. These two buffers are used by the TouCAN for buffering both received messages and messages to be transmitted. Only one serial message buffer is active at a time, and its function depends upon the operation of the TouCAN at that time. At no time does the user have access to or visibility of these two buffers.

#### 13.4.1.5 Message Buffer Activation/Deactivation Mechanism

Each message buffer must be activated once it is configured for the desired operation by the user. A buffer is activated by writing the appropriate code to the control/status word for that buffer. Once the buffer is activated, it will begin participating in the normal transmit and receive processes.

Likewise, a buffer is deactivated by writing the appropriate deactivation code to the control/status word for that buffer. Deactivation of a buffer is typically done when the user desires to reconfigure the buffer, for example to change the buffer's function (RX to TX or TX to RX). Deactivation should also be done before changing a receive buffer's message identifier or before loading a new message to be transmitted into a transmit buffer.

For more details on activation and deactivation of message buffers, and the effects on message buffer operation, refer to **13.5 TouCAN Operation**.

#### 13.4.1.6 Message Buffer Lock/Release/Busy Mechanism

In addition to the activation/deactivation mechanism, the TouCAN also utilizes a lock/release/busy mechanism to assure data coherency during the receive process. The mechanism includes a lock status for each message buffer, and utilizes the two serial message buffers to facilitate frame transfers within the TouCAN.

Reading the control/status word of a receive message buffer triggers the lock for that buffer. While locked, a received message cannot be transferred into that buffer from one of the SMBs.

If a message transfer between the message buffer and a serial message buffer is in progress when the control/status word is read, the BUSY status will be indicated in the code field, and the lock will not be activated.

The user can release the lock on a message buffer in one of two ways. Reading the control/status word of another message buffer will lock that buffer, releasing the previously locked buffer. A global release can also be performed on any locked message buffer by reading the free-running timer.

Once a lock is released, any message transfers between an SMB and a message buffer which was delayed due to that buffer being locked will take place. For more details on the message buffer locking mechanism, and the effects on message buffer operation, refer to **13.5 TouCAN Operation**.

### 13.4.2 Receive Mask Registers

The receive mask registers are used as acceptance masks for received frame IDs. The following masks are defined:

- A global mask, used for receive buffers 0-13
- Two separate masks for buffers 14 and 15

The value of the mask registers should not be changed during normal operation. If the mask register data is changed after the masked identifier of a received message is matched to a locked message buffer, that message will be transferred into that message buffer once it is unlocked, regardless of whether that message's masked identifier still matches the receive buffer identifier. **Table 13-6** shows mask bit values.

**Table 13-6 Receive Mask Register Bit Values**

Mask Bit	Values
0	The corresponding incoming ID bit is "don't care".
1	The corresponding ID bit is checked against the incoming ID bit to see if a match exists.

**Table 13-7** shows mask examples for normal and extended messages. Refer to **APPENDIX D REGISTER SUMMARY** for more information on RX mask registers.

**Table 13-7 Mask Examples for Normal/Extended Messages**

Message Buffer (MB) /Mask	Base ID ID[28:18]	IDE	Extended ID ID[17:0]	Match
MB2	1 1 1 1 1 1 1 1 0 0 0	0	—	—
MB3	1 1 1 1 1 1 1 1 0 0 0	1	0 1 0 1 0 1 0 1 0 1 0 1 0 1 0 1	—
MB4	0 0 0 0 0 0 1 1 1 1 1	0	—	—
MB5	0 0 0 0 0 0 1 1 1 0 1	1	0 1 0 1 0 1 0 1 0 1 0 1 0 1 0 1	—
MB14	1 1 1 1 1 1 1 1 0 0 0	1	0 1 0 1 0 1 0 1 0 1 0 1 0 1 0 1	—
RX Global Mask	1 1 1 1 1 1 1 1 1 1 0		1 1 1 1 1 1 1 0 0 0 0 0 0 0 0 0 0 1	—
RX Message In	1 1 1 1 1 1 1 1 0 0 1	1	0 1 0 1 0 1 0 1 0 1 0 1 0 1 0 1	3 <sup>1</sup>
	1 1 1 1 1 1 1 1 0 0 1	0	—	2 <sup>2</sup>
	1 1 1 1 1 1 1 1 0 0 1	1	0 1 0 1 0 1 0 1 0 1 0 1 0 1 0 0	— <sup>3</sup>
	0 1 1 1 1 1 1 1 0 0 0	0	—	— <sup>4</sup>
	0 1 1 1 1 1 1 1 0 0 0	1	0 1 0 1 0 1 0 1 0 1 0 1 0 1 0 1	— <sup>5</sup>
RX 14 Mask	0 1 1 1 1 1 1 1 1 1 1		1 1 1 1 1 1 1 0 0 0 0 0 0 0 0 0 0 0	—
RX Message In	1 0 1 1 1 1 1 1 0 0 0	1	0 1 0 1 0 1 0 1 0 1 0 1 0 1 0 1	— <sup>6</sup>
	0 1 1 1 1 1 1 1 0 0 0	1	0 1 0 1 0 1 0 1 0 1 0 1 0 1 0 1	14 <sup>7</sup>

NOTES:

1. Match for extended format (MB3).
2. Match for standard format (MB2).
3. No match for MB3 because of ID0.
4. No match for MB2 because of ID28.
5. No match for MB3 because of ID28, match for MB14.
6. No match for MB14 because of ID27.
7. Match for MB14.

### 13.4.3 Bit Timing

The TouCAN module uses three 8-bit registers to set-up the bit timing parameters required by the CAN protocol. Control registers 1 and 2 (CANCTRL1, CANCTRL2) contain the PROPSEG, PSEG1, PSEG2, and the RJW fields which allow the user to configure the bit timing parameters. The prescaler divide register (PRESDIV) allows the user to select the ratio used to derive the S-clock from the system clock. The time quanta clock operates at the S-clock frequency. **Table 13-8** provides examples of system clock, CAN bit rate, and S-clock bit timing parameters. Refer to **APPENDIX D REGISTER SUMMARY** for more information on the bit timing registers.



**Table 13-8 Example System Clock, CAN Bit Rate and S-Clock Frequencies**

System Clock Frequency (MHz)	CAN Bit-Rate (MHz)	Possible S-Clock Frequency (MHz)	Possible Number of Time Quanta/Bit	PRESDIV Value + 1
25	1	25	25	1
20	1	10, 20	10, 20	2, 1
16	1	8, 16	8, 16	2, 1
25	0.125	1, 1.25, 2.5	8,10, 20	25, 20,10
20	0.125	1, 2, 2.5	8, 16, 20	20, 10, 8
16	0.125	1, 2	8,16	16, 8

### 13.4.3.1 Configuring the TouCAN Bit Timing

The following considerations must be observed when programming bit timing functions.

- If the programmed PRESDIV value results in a single system clock per one time quantum, then the PSEG2 field in CANCTRL2 register should not be programmed to zero.
- If the programmed PRESDIV value results in a single system clock per one time quantum, then the information processing time (IPT) equals three time quanta, otherwise it equals two time quanta. If PSEG2 equals two, then the TouCAN transmits one time quantum late relative to the scheduled sync segment.
- If the prescaler and bit timing control fields are programmed to values that result in fewer than ten system clock periods per CAN bit time and the CAN bus loading is 100%, anytime the rising edge of a start-of-frame (SOF) symbol transmitted by another node occurs during the third bit of the intermission between messages, the TouCAN may not be able to prepare a message buffer for transmission in time to begin its own transmission and arbitrate against the message which transmitted the early SOF.
- The TouCAN bit time must be programmed to be greater than or equal to nine system clocks, or correct operation is not guaranteed.

### 13.4.4 Error Counters

The TouCAN has two error counters, the transmit (TX) error counter and the receive (RX) error counter. Refer to **APPENDIX D REGISTER SUMMARY** for more information on error counters. The rules for increasing and decreasing these counters are described in the CAN protocol, and are fully implemented in the TouCAN. Each counter has the following features:

- 8-bit up/down counter
- Increment by 8 (RX error counter also increments by one)
- Decrement by one
- Avoid decrement when equal to zero
- RX error counter reset to a value between 119 and 127 inclusive, when the TouCAN transitions from error passive to error active
- Following reset, both counters reset to zero
- Detect values for error passive, bus off and error active transitions

- Cascade usage of TX error counter with an additional internal counter to detect the 128 occurrences of 11 consecutive recessive bits necessary to transition from bus off into error active.

Both counters are read only (except in test/freeze/halt modes).

The TouCAN responds to any bus state as described in the CAN protocol, transmitting an error active or error passive flag, delaying its transmission start time (error passive) and avoiding any influence on the bus when in the bus off state. The following are the basic rules for TouCAN bus state transitions:

- If the value of the TX error counter or RX error counter increments to a value greater than or equal to 128, the fault confinement state (FCS[1:0]) field in the error status register is updated to reflect an error passive state.
- If the TouCAN is in an error passive state, and either the TX error counter or RX error counter decrements to a value less than or equal to 127, while the other error counter already satisfies this condition, the FCS[1:0] field in the error status register is updated to reflect an error active state.
- If the value of the TX error counter increases to a value greater than 255, the FCS[1:0] field in the error status register is updated to reflect a bus off state, and an interrupt may be issued. The value of the TX error counter is reset to zero.
- If the TouCAN is in the bus off state, the TX error counter and an additional internal counter are cascaded to count 128 occurrences of 11 consecutive recessive bits on the bus. To do this, the TX error counter is first reset to zero, then the internal counter begins counting consecutive recessive bits. Each time the internal counter counts 11 consecutive recessive bits, the TX error counter is incremented by one and the internal counter is reset to zero. When the TX error counter reaches the value of 128, the FCS[1:0] field in the error status register is updated to be error active, and both error counters are reset to zero. Any time a dominant bit is detected following a stream of less than 11 consecutive recessive bits, the internal counter resets itself to zero, but does not affect the TX error counter value.
- If only one node is operating in a system, the TX error counter will increment with each message it attempts to transmit, due to the resulting acknowledgment errors. However, acknowledgment errors will never cause the TouCAN to transition from the error passive state to the bus off state.
- If the RX error counter increments to a value greater than 127, it will stop incrementing, even if more errors are detected while being a receiver. After the next successful message reception, the counter is reset to a value between 119 and 127, to enable a return to the error active state.

#### 13.4.5 Time Stamp

The value of the free-running 16-bit timer is sampled at the beginning of the identifier field on the CAN bus. For a message being received, the time stamp will be stored in the time stamp entry of the receive message buffer at the time the message is written into that buffer. For a message being transmitted, the time stamp entry will be written into the transmit message buffer once the transmission has completed successfully.

The free-running timer can optionally be reset upon the reception of a frame into message buffer 0. This feature allows network time synchronization to be performed.

## 13.5 TouCAN Operation

The basic operation of the TouCAN can be divided into three areas:

- Reset and initialization of the module
- Transmit message handling
- Receive message handling

Example sequences for performing each of these processes is given in the following paragraphs.

### 13.5.1 TouCAN Reset

The TouCAN can be reset in two ways:

- Hard reset, using one of the IMB reset lines.
- Soft reset, using the SOFTRST bit in the module configuration register.

Following the negation of reset, the TouCAN is not synchronized with the CAN bus, and the HALT, FRZ, and FRZACK bits in the module configuration register are set. In this state, the TouCAN does not initiate frame transmissions or receive any frames from the CAN bus. The contents of the message buffers are not changed following reset.

Any configuration change/initialization requires that the TouCAN be frozen by either asserting the HALT bit in the module configuration register or by reset.

### 13.5.2 TouCAN Initialization

Initialization of the TouCAN includes the initial configuration of the message buffers and configuration of the CAN communication parameters following a reset, as well as any reconfiguration which may be required during operation. The following is a generic initialization sequence for the TouCAN:

- A. Initialize all operation modes
  1. Initialize the transmit and receive pin modes in control register 0 (CANCTRL0).
  2. Initialize the bit timing parameters PROPSEG, PSEG1, PSEG2, and RJW in control registers 1 and 2 (CANCTRL[1:2]).
  3. Select the S-clock rate by programming the PRES DIV register.
  4. Select the internal arbitration mode (LBUF bit in CANCTRL1).
- B. Initialize message buffers
  1. The control/status word of all message buffers must be written either as an active or inactive message buffer.
  2. All other entries in each message buffer should be initialized as required.
- C. Initialize mask registers for acceptance mask as needed
- D. Initialize TouCAN interrupt handler
  1. Initialize the interrupt configuration register (CANICR) with a specific request level and vector base address.

2. Initialize IARB[3:0] to a non-zero value in CANMCR.
  3. Set the required mask bits in the IMASK register (for all message buffer interrupts), in CANCTRL0 (for bus off and error interrupts), and in CANMCR for the WAKE interrupt.
- E. Negate the HALT bit in the module configuration register
1. At this point, the TouCAN will attempt to synchronize with the CAN bus.

#### **NOTE**

In both the transmit and receive processes, the first action in preparing a message buffer should be to deactivate the buffer by setting its code field to the proper value. This requirement is mandatory to assure data coherency.

### **13.5.3 Transmit Process**

The transmit process includes preparing a message buffer for transmission, as well as the internal steps performed by the TouCAN to decide which message to transmit. For the user, this involves loading the message and ID to be transmitted into a message buffer and then activating that buffer as an active transmit buffer. Once this is done, the TouCAN will perform all additional steps necessary to transmit the message onto the CAN bus.

The user should prepare/change a message buffer for transmission by executing the following steps.

1. Write the control/status word to hold the transmit buffer inactive (code = %1000)
2. Write the ID\_HIGH and ID\_LOW words
3. Write the data bytes
4. Write the control/status word (active TX code, TX length)

#### **NOTE**

Steps 1 and 4 are mandatory to ensure data coherency while preparing a message buffer for transmission.

Once an active transmit code is written to a transmit message buffer, that buffer will begin participating in an internal arbitration process as soon as the CAN bus is sensed to be free by the receiver, or at the inter-frame space. If there are multiple messages awaiting transmission, this internal arbitration process selects the message buffer from which the next frame is transmitted.

When this process is over, and a message buffer is selected for transmission, the frame from that message buffer is transferred to the serial message buffer for transmission.

While transmitting, the TouCAN will transmit no more than eight data bytes, even if the transmit length contains a value greater than eight.

At the end of a successful transmission, the value of the free-running timer (which was captured at the beginning of the identifier field on the CAN bus), is written into the time stamp field in the message buffer. The code field in the control/status word of the message buffer is updated and a status flag is set in the IFLAG register.

### 13.5.3.1 Transmit Message Buffer Deactivation

Any write access to the control/status word of a transmit message buffer during the process of selecting a message buffer for transmission immediately deactivates that message buffer, removing it from the transmission process.

While a message is being transferred from a transmit message buffer to a serial message buffer, if the user deactivates that transmit message buffer, the message will not be transmitted.

If the user deactivates the transmit message buffer after the message is transferred to the serial message buffer, the message will be transmitted, but no interrupt will be requested and the transmit code will not be updated.

If a message buffer containing the lowest ID is deactivated while that message is undergoing the internal arbitration process to determine which message should be sent, then that message may not be transmitted.

### 13.5.3.2 Reception of Transmitted Frames

The TouCAN will receive a frame it has transmitted if an empty message buffer with a matching identifier exists.

### 13.5.4 Receive Process

The receive process includes configuring message buffers for reception, the transfer of received messages by the TouCAN from the serial message buffers to the receive message buffers with matching IDs, and the retrieval of these messages by the user.

The user should prepare/change a message buffer for frame reception by executing the following steps.

1. Write the control/status word to hold the receive buffer inactive (code = %0000).
2. Write the ID\_HIGH and ID\_LOW words.
3. Write the control/status word to mark the receive message buffer as active and empty.

#### NOTE

Steps 1 and 3 are mandatory for data coherency while preparing a message buffer for reception.

Once these steps are performed, the message buffer functions as an active receive buffer and participates in the internal matching process, which takes place every time the TouCAN receives an error-free frame. In this process, all active receive buffers compare their ID value to the newly received one. If a match is detected, the following actions occur:

1. The frame is transferred to the first (lowest entry) matching receive message buffer.
2. The value of the free-running timer (captured at the beginning of the identifier field on the CAN bus) is written into the time stamp field in the message buffer.
3. The ID field, data field and RX length field are stored.
4. The code field is updated.
5. The status flag is set in the IFLAG register.

The user should read a received frame from its message buffer in the following order:

1. Control/status word (mandatory, as it activates the internal lock for this buffer)
2. ID (optional, since it is needed only if a mask was used)
3. Data field word(s)
4. Free-running timer (optional, as it releases the internal lock)

If a read of the free running timer is not performed, that message buffer remains locked until the read process starts for another message buffer. Only a single message buffer is locked at a time. When reading a received message, the only mandatory read operation is that of the control/status word. This assures data coherency.

If the BUSY bit is set in the message buffer code, the CPU32 should defer accessing that buffer until this bit is negated. Refer to **Table 13-2**.

#### **NOTE**

The CPU32 should check the status of a message buffer by reading the status flag in the IFLAG register and not by reading the control/status word code field for that message buffer. This prevents the buffer from being locked inadvertently.

Because the received identifier field is always stored in the matching receive message buffer, the contents of the identifier field in a receive message buffer may change if one or more of the ID bits are masked.

#### **13.5.4.1 Receive Message Buffer Deactivation**

Any write access to the control/status word of a receive message buffer during the process of selecting a message buffer for reception immediately deactivates that message buffer, removing it from the reception process.

If a receive message buffer is deactivated while a message is being transferred into it, the transfer is halted and no interrupt is requested. If this occurs, that receive message buffer may contain mixed data from two different frames.

Data should never be written into a receive message buffer. If this is done while a message is being transferred from a serial message buffer, the control/status word will reflect a full or overrun condition, but no interrupt will be requested.

#### 13.5.4.2 Locking and Releasing Message Buffers

The lock/release/busy mechanism is designed to guarantee data coherency during the receive process. The following examples demonstrate how the lock/release/busy mechanism will affect TouCAN operation.

1. Reading a control/status word of a message buffer triggers a lock for that message buffer. A new received message frame which matches the message buffer cannot be written into this message buffer while it is locked.
2. To release a locked message buffer, the CPU32 either locks another message buffer by reading its control/status word, or globally releases any locked message buffer by reading the free-running timer.
3. If a receive frame with a matching ID is received during the time the message buffer is locked, the receive frame will not be immediately transferred into that message buffer, but will remain in the serial message buffer. There is no indication when this occurs.
4. When a locked message buffer is released, if a frame with a matching identifier exists within the serial message buffer, then this frame will be transferred to the matching message buffer.
5. If two or more receive frames with matching IDs are received while a message buffer with a matching ID is locked, the last received frame with that ID is kept within the serial message buffer, while all preceding ones are lost. There is no indication when this occurs.
6. If the user reads the control/status word of a receive message buffer while a frame is being transferred from a serial message buffer, the BUSY code will be indicated. The user should wait until this code is cleared before continuing to read from the message buffer to ensure data coherency. In this situation, the read of the control/status word will not lock the message buffer.

Polling the control/status word of a receive message buffer can lock it, preventing a message from being transferred into that buffer. If the control/status word of a receive message buffer is read, it should then be followed by a read of the control/status word of another buffer, or by reading the free-running timer, to ensure that the locked buffer is unlocked.

#### 13.5.5 Remote Frames

The remote frame is a message frame which is transmitted to request a data frame. The TouCAN can be configured to transmit a data frame automatically in response to a remote frame, or to transmit a remote frame and then wait for the responding data frame to be received.

When transmitting a remote frame, the user initializes a message buffer as a transmit message buffer with the RTR bit set to one. Once this remote frame is transmitted successfully, the transmit message buffer automatically becomes a receive message buffer, with the same ID as the remote frame which was transmitted.

When a remote frame is received by the TouCAN, the remote frame ID is compared to the IDs of all transmit message buffers programmed with a code of 1010. If there is an exact matching ID, the data frame in that message buffer is transmitted. If the RTR

bit in the matching transmit message buffer is set, the TouCAN will transmit a remote frame as a response.

A received remote frame is not stored in a receive message buffer. It is only used to trigger the automatic transmission of a frame in response. The mask registers are not used in remote frame ID matching. All ID bits (except RTR) of the incoming received frame must match for the remote frame to trigger a response transmission.

### 13.5.6 Overload Frames

Overload frame transmissions are not initiated by the TouCAN unless certain conditions are detected on the CAN bus. These conditions include:

- Detection of a dominant bit in the first or second bit of intermission.
- Detection of a dominant bit in the seventh (last) bit of the end-of-frame (EOF) field in receive frames.
- Detection of a dominant bit in the eighth (last) bit of the error frame delimiter or overload frame delimiter.

### 13.6 Special Operating Modes

The TouCAN module has three special operating modes:

- Debug mode
- Low-power stop mode
- Auto power save mode

#### 13.6.1 Debug Mode

Debug mode is entered by setting the HALT bit in the CANMCR, or by assertion of the IMB FREEZE line. In both cases, the FRZ1 bit in CANMCR must also be set to allow HALT or FREEZE to place the TouCAN in debug mode.

Once entry into debug mode is requested, the TouCAN waits until an intermission or idle condition exists on the CAN bus, or until the TouCAN enters the error passive or bus off state. Once one of these conditions exists, the TouCAN waits for the completion of all internal activity. When this happens, the following events occur:

- The TouCAN stops transmitting/receiving frames.
- The prescaler is disabled, thus halting all CAN bus communication.
- The TouCAN ignores its RX pins and drives its TX pins as recessive.
- The TouCAN loses synchronization with the CAN bus and the NOTRDY and FRZACK bits in CANMCR are set.
- The CPU32 is allowed to read and write the error counter registers.

After engaging one of the mechanisms to place the TouCAN in debug mode, the user must wait for the FRZACK bit to be set before accessing any other registers in the TouCAN, otherwise unpredictable operation may occur.

To exit debug mode, the IMB FREEZE line must be negated or the HALT bit in CANMCR must be cleared.



Once debug mode is exited, the TouCAN will resynchronize with the CAN bus by waiting for 11 consecutive recessive bits before beginning to participate in CAN bus communication.

### 13.6.2 Low-Power Stop Mode

Before entering low-power stop mode, the TouCAN will wait for the CAN bus to be in an idle state, or for the third bit of intermission to be recessive. The TouCAN then waits for the completion of all internal activity (except in the CAN bus interface) to be complete. Afterwards, the following events occur:

- The TouCAN shuts down its clocks, stopping most internal circuits, thus achieving maximum power savings.
- The bus interface unit continues to operate, allowing the CPU32 to access the module configuration register.
- The TouCAN ignores its RX pins and drives its TX pins as recessive.
- The TouCAN loses synchronization with the CAN bus, and the STOPACK and NOTRDY bits in the module configuration register are set.

To exit low-power stop mode:

- Reset the TouCAN either by asserting one of the IMB reset lines or by asserting the SOFTRST bit CANMCR.
- Clear the STOP bit in CANMCR.
- The TouCAN module can optionally exit low-power stop mode via the self-wake mechanism. If the SELFWAKE bit in CANMCR was set at the time the TouCAN entered stop mode, then upon detection of a recessive to dominant transition on the CAN bus, the TouCAN clears the STOP bit in CANMCR and its clocks begin running.

When in low-power stop mode, a recessive to dominant transition on the CAN bus causes the WAKEINT bit in the error and status register (ESTAT) to be set. This event can generate an interrupt if the WAKEMSK bit in CANMCR is set.

Consider the following notes regarding low-power stop mode:

- When the self-wake mechanism activates, the TouCAN tries to receive the frame that woke it up. (It assumes that the dominant bit detected is a start-of-frame bit). It will not arbitrate for the CAN bus at this time.
- If the STOP bit is set while the TouCAN is in the bus off state, then the TouCAN will enter low-power stop mode and stop counting recessive bit times. The count will continue when STOP is cleared.
- To place the TouCAN in low-power stop mode with the self-wake mechanism engaged, write to CANMCR with both STOP and SELFWAKE set, then wait for the TouCAN to set the STOPACK bit.
- To take the TouCAN out of low-power stop mode when the self-wake mechanism is enabled, write to CANMCR with both STOP and SELFWAKE clear, then wait for the TouCAN to clear the STOPACK bit.
- The SELFWAKE bit should not be set after the TouCAN has already entered low-power stop mode.

- If both STOP and SELFWAKE are set and a recessive to dominant edge immediately occurs on the CAN bus, the TouCAN may never set the STOPACK bit, and the STOP bit will be cleared.
- To prevent old frames from being sent when the TouCAN awakes from low-power stop mode via the self-wake mechanism, disable all transmit sources, including transmit buffers configured for remote request responses, before placing the TouCAN in low-power stop mode.
- If the TouCAN is in debug mode when the STOP bit is set, the TouCAN will assume that debug mode should be exited. As a result, it will try to synchronize with the CAN bus, and only then will it await the conditions required for entry into low-power stop mode.
- Unlike other modules, the TouCAN does not come out of reset in low-power stop mode. The basic TouCAN initialization procedure (see **13.5.2 TouCAN Initialization**) should be executed before placing the module in low-power stop mode.
- If the TouCAN is in low-power stop mode with the self-wake mechanism engaged and is operating with a single system clock per time quantum, there can be extreme cases in which TouCAN wake-up on recessive to dominant edge may not conform to the CAN protocol. TouCAN synchronization will be shifted one time quantum from the wake-up event. This shift lasts until the next recessive to dominant edge, which resynchronizes the TouCAN to be in conformance with the CAN protocol. The same holds true when the TouCAN is in auto power save mode and awakens on a recessive to dominant edge.

### 13.6.3 Auto Power Save Mode

Auto power save mode enables normal operation with optimized power savings. Once the auto power save (APS) bit in CANMCR is set, the TouCAN looks for a set of conditions in which there is no need for the clocks to be running. If these conditions are met, the TouCAN stops its clocks, thus saving power. The following conditions will activate auto power save mode.

- No RX/TX frame in progress.
- No transfer of RX/TX frames to and from a serial message buffer, and no TX frame awaiting transmission in any message buffer.
- No CPU32 access to the TouCAN module.
- The TouCAN is not in debug mode, low-power stop mode, or the bus off state.

While its clocks are stopped, if the TouCAN senses that any one of the aforementioned conditions is no longer true, it restarts its clocks. The TouCAN then continues to monitor these conditions and stops/restarts its clocks accordingly.

## 13.7 Interrupts

The TouCAN is capable of generating one interrupt level on the IMB. This level is programmed into the priority level bits in the interrupt configuration register (CANICR). This value determines which interrupt signal is driven onto the bus when an interrupt is requested.

When an interrupt is requested, the CPU32 initiates an IACK cycle. The TouCAN decodes the IACK cycle and compares the CPU32 recognized level to the level that it is currently requesting. If a match occurs, then arbitration begins. If the TouCAN wins arbitration, it generates a uniquely encoded interrupt vector that indicates which event is requesting service. This encoding scheme is as follows:

- The higher-order bits of the interrupt vector come from the IVBA[2:0] field in CANICR.
- The low-order five bits are an encoded value that indicate which of the 19 TouCAN interrupt sources is requesting service.

Figure 13-5 shows a block diagram of the interrupt hardware.

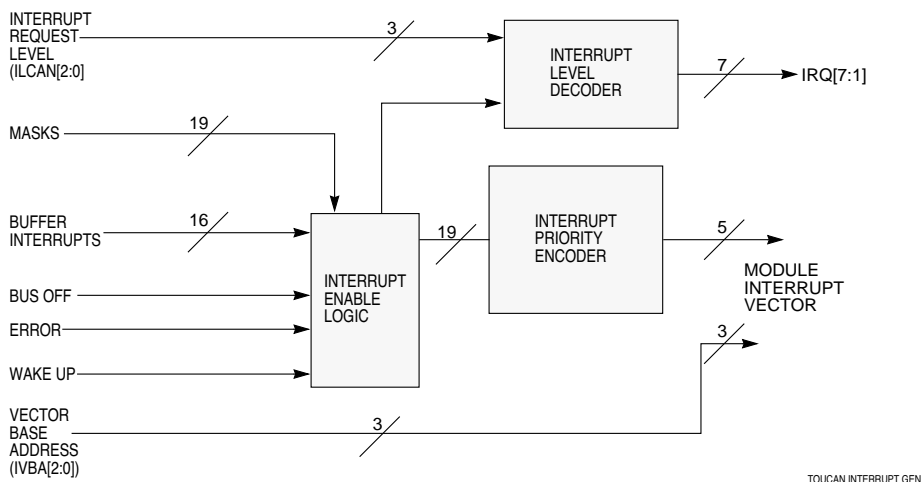

Figure 13-5 TouCAN Interrupt Vector Generation

Each one of the 16 message buffers can be an interrupt source, if its corresponding IMASK bit is set. There is no distinction between transmit and receive interrupts for a particular buffer. Each of the buffers is assigned a bit in the IFLAG register. An IFLAG bit is set when the corresponding buffer completes a successful transmission/reception. An IFLAG bit is cleared when the CPU32 reads IFLAG while the associated bit is set, and then writes it back as zero (and no new event of the same type occurs between the read and the write actions).

The other three interrupt sources (bus off, error and wake up) act in the same way, and have flag bits located in the error and status register (ESTAT). The bus off and error interrupt mask bits (BOFFMSK and ERRMSK) are located in CANCTRL0, and the wake up interrupt mask bit (WAKEMSK) is located in the module configuration register. Refer to **APPENDIX D REGISTER SUMMARY** for more information on these registers. **Table 13-9** shows TouCAN interrupt priorities and their corresponding vector addresses.

**Table 13-9 Interrupt Sources and Vector Addresses**

<b>Interrupt Source</b>	<b>Vector Number</b>
Buffer 0	%XXX00000 (Highest priority)
Buffer 1	%XXX00001
Buffer 2	%XXX00010
Buffer 3	%XXX00011
Buffer 4	%XXX00100
Buffer 5	%XXX00101
Buffer 6	%XXX00110
Buffer 7	%XXX00111
Buffer 8	%XXX01000
Buffer 9	%XXX01001
Buffer 10	%XXX01010
Buffer 11	%XXX01011
Buffer 12	%XXX01100
Buffer 13	%XXX01101
Buffer 14	%XXX01110
Buffer 15	%XXX01111
Bus off	%XXX10000
Error	%XXX10001
Wake-up	%XXX10010 (Lowest priority)

## APPENDIX A ELECTRICAL CHARACTERISTICS

This appendix contains electrical specification tables and reference timing diagrams for MC68336 and MC68376 microcontroller units.

**Table A-1 Maximum Ratings**

Num	Rating	Symbol	Value	Unit
1	Supply Voltage <sup>1, 2,</sup>	$V_{DD}$	- 0.3 to + 6.5	V
2	Input Voltage <sup>1, 2, 3, 5, 7</sup>	$V_{in}$	- 0.3 to + 6.5	V
3	Instantaneous Maximum Current Single pin limit (applies to all pins) <sup>1, 5, 6, 7</sup>	$I_D$	25	mA
4	Operating Maximum Current Digital Input Disruptive Current <sup>4, 5, 6, 7, 8</sup> $V_{NEGCLMAP} \equiv -0.3$ V $V_{POSCLAMP} \equiv V_{DD} + 0.3$	$I_{ID}$	- 500 to 500	$\mu$ A
5	Operating Temperature Range MC68336/376 "C" Suffix MC68336/376 "V" Suffix MC68336/376 "M" Suffix	$T_A$	$T_L$ to $T_H$ - 40 to 85 - 40 to 105 - 40 to 125	$^{\circ}$ C
6	Storage Temperature Range	$T_{stg}$	- 55 to 150	$^{\circ}$ C

NOTES:

1. Permanent damage can occur if maximum ratings are exceeded. Exposure to voltages or currents in excess of recommended values affects device reliability. Device modules may not operate normally while being exposed to electrical extremes.
2. Although sections of the device contain circuitry to protect against damage from high static voltages or electrical fields, take normal precautions to avoid exposure to voltages higher than maximum-rated voltages.
3. All pins except TSTME/TSC.
4. All functional non-supply pins are internally clamped to  $V_{SS}$ . All functional pins except EXTAL and XFC are internally clamped to  $V_{DD}$ . Does not include QADC pins (refer to **Table A-11**).
5. Input must be current limited to the value specified. To determine the value of the required current-limiting resistor, calculate resistance values for positive and negative clamp voltages, then use the larger of the two values.
6. Power supply must maintain regulation within operating  $V_{DD}$  range during instantaneous and operating maximum current conditions.
7. This parameter is periodically sampled rather than 100% tested.
8. Total input current for all digital input-only and all digital input/output pins must not exceed 10 mA. Exceeding this limit can cause disruption of normal operation.

**Table A-2 Typical Ratings**

Num	Rating	Symbol	Value	Unit
1	Supply Voltage	$V_{DD}$	5.0	V
2	Operating Temperature	$T_A$	25	°C
3	$V_{DD}$ Supply Current RUN LPSTOP, VCO off LPSTOP, External clock, maxi $f_{sys}$	$I_{DD}$	113 125 3.75	mA μA mA
4	Clock Synthesizer Operating Voltage	$V_{DDSYN}$	5.0	V
5	$V_{DDSYN}$ Supply Current VCO on, maximum $f_{sys}$ External Clock, maximum $f_{sys}$ LPSTOP, VCO off $V_{DD}$ powered down	$I_{DDSYN}$	1.0 5.0 100 50	mA mA μA μA
6	RAM Standby Voltage	$V_{SB}$	3.0	V
7	RAM Standby Current Normal RAM operation Standby operation	$I_{SB}$	7.0 40	μA μA
8	Power Dissipation	$P_D$	570	mW

**Table A-3 Thermal Characteristics**

Num	Rating	Symbol	Value	Unit
1	Thermal Resistance Plastic 160-Pin Surface Mount	$\theta_{JA}$	37	°C/W

The average chip-junction temperature ( $T_J$ ) in C can be obtained from:

$$T_J = T_A + (P_D \times \theta_{JA}) \quad (1)$$

where:

- $T_A$  = Ambient Temperature, °C
- $\theta_{JA}$  = Package Thermal Resistance, Junction-to-Ambient, °C/W
- $P_D$  =  $P_{INT} + P_{I/O}$
- $P_{INT}$  =  $I_{DD} \times V_{DD}$ , Watts — Chip Internal Power
- $P_{I/O}$  = Power Dissipation on Input and Output Pins — User Determined

For most applications  $P_{I/O} < P_{INT}$  and can be neglected. An approximate relationship between  $P_D$  and  $T_J$  (if  $P_{I/O}$  is neglected) is:

$$P_D = K + (T_J + 273^\circ\text{C}) \quad (2)$$

Solving equations 1 and 2 for K gives:

$$K = P_D + (T_A + 273^\circ\text{C}) + \theta_{JA} \times P_{D^2} \quad (3)$$

where K is a constant pertaining to the particular part. K can be determined from equation (3) by measuring  $P_D$  (at equilibrium) for a known  $T_A$ . Using this value of K, the values of  $P_D$  and  $T_J$  can be obtained by solving equations (1) and (2) iteratively for any value of  $T_A$ .

### Table A-4 Clock Control Timing

( $V_{DD}$  and  $V_{DDSYN} = 5.0 \text{ Vdc} \pm 5\%$ ,  $V_{SS} = 0 \text{ Vdc}$ ,  $T_A = T_L$  to  $T_H$ , 4.194 MHz reference)

Num	Characteristic	Symbol	Min	Max	Unit
1	PLL Reference Frequency Range	$f_{ref}$	4.194	5.243	MHz
2	System Frequency <sup>1</sup> On-Chip PLL System Frequency External Clock Operation	$f_{sys}$	dc $f_{ref}/32$ dc	20.97 20.97 20.97	MHz
3	PLL Lock Time <sup>2, 3, 4, 5</sup>	$t_{pll}$	—	20	ms
4	VCO Frequency <sup>6</sup>	$f_{VCO}$	—	$2 (f_{sys} \text{ max})$	MHz
5	Limp Mode Clock Frequency SYNCR X bit = 0 SYNCR X bit = 1	$f_{limp}$	— —	$f_{sys} \text{ max}/2$ $f_{sys} \text{ max}$	MHz
6	CLKOUT Jitter <sup>2, 3, 4, 7</sup> Short term (5 $\mu\text{s}$ interval) Long term (500 $\mu\text{s}$ interval)	$J_{clk}$	-0.625 -0.0625	-0.625 -0.0625	%

NOTES:

- All internal registers retain data at 0 Hz.
- This parameter is periodically sampled rather than 100% tested.
- Assumes that a low-leakage external filter network is used to condition clock synthesizer input voltage. Total external resistance from the XFC pin due to external leakage must be greater than 15 M $\Omega$  to guarantee this specification. Filter network geometry can vary depending upon operating environment.
- Proper layout procedures must be followed to achieve specifications.
- Assumes that stable  $V_{DDSYN}$  is applied, and that the crystal oscillator is stable. Lock time is measured from the time  $V_{DD}$  and  $V_{DDSYN}$  are valid until  $\overline{\text{RESET}}$  is released. This specification also applies to the period required for PLL lock after changing the W and Y frequency control bits in the synthesizer control register (SYNCR) while the PLL is running, and to the period required for the clock to lock after LPSTOP.
- Internal VCO frequency ( $f_{VCO}$ ) is determined by SYNCR W and Y bit values. The SYNCR X bit controls a divide-by-two circuit that is not in the synthesizer feedback loop. When X = 0, the divider is enabled, and  $f_{sys} = f_{VCO} \div 2$ . When X = 1, the divider is disabled, and  $f_{sys} = f_{VCO} \div 4$ . X must equal one when operating at maximum specified  $f_{sys}$ .
- Jitter is the average deviation from the programmed frequency measured over the specified interval at maximum  $f_{sys}$ . Measurements are made with the device powered by filtered supplies and clocked by a stable external clock signal. Noise injected into the PLL circuitry via  $V_{DDSYN}$  and  $V_{SS}$  and variation in crystal oscillator frequency increase the  $J_{clk}$  percentage for a given interval. When jitter is a critical constraint on control system operation, this parameter should be measured during functional testing of the final system.

### Table A-5 DC Characteristics

( $V_{DD}$  and  $V_{DDSYN} = 5.0 \text{ Vdc} \pm 5\%$ ,  $V_{SS} = 0 \text{ Vdc}$ ,  $T_A = T_L$  to  $T_H$ )

Num	Characteristic	Symbol	Min	Max	Unit
1	Input High Voltage	$V_{IH}$	0.7 ( $V_{DD}$ )	$V_{DD} + 0.3$	V
2	Input Low Voltage	$V_{IL}$	$V_{SS} - 0.3$	0.2 ( $V_{DD}$ )	V
3	Input Hysteresis <sup>1</sup>	$V_{HYS}$	0.5	—	V
4	Input Leakage Current <sup>2</sup> $V_{in} = V_{DD}$ or $V_{SS}$ Input-only pins	$I_{in}$	-2.5	2.5	$\mu\text{A}$
5	High Impedance (Off-State) Leakage Current <sup>2</sup> $V_{in} = V_{DD}$ or $V_{SS}$ All input/output and output pins	$I_{OZ}$	-2.5	2.5	$\mu\text{A}$
6	CMOS Output High Voltage <sup>2, 3</sup> $I_{OH} = -10.0 \mu\text{A}$ Group 1, 2, 4 input/output and all output pins	$V_{OH}$	$V_{DD} - 0.2$	—	V
7	CMOS Output Low Voltage <sup>2</sup> $I_{OL} = 10.0 \mu\text{A}$ Group 1, 2, 4 input/output and all output pins	$V_{OL}$	—	0.2	V
8	Output High Voltage <sup>2, 3</sup> $I_{OH} = -0.8 \text{ mA}$ Group 1, 2, 4 input/output and all output pins	$V_{OH}$	$V_{DD} - 0.8$	—	V
9	Output Low Voltage <sup>2</sup> $I_{OL} = 1.6 \text{ mA}$ Group 1 I/O Pins, CLKOUT, FREEZE/QUOT, IPIPE $I_{OL} = 5.3 \text{ mA}$ Group 2 and Group 4 I/O Pins, CSBOOT, BG/CS $I_{OL} = 12 \text{ mA}$ Group 3	$V_{OL}$	— — —	0.4 0.4 0.4	V
10	Three State Control Input High Voltage	$V_{IHTSC}$	1.6 ( $V_{DD}$ )	9.1	V
11	Data Bus Mode Select Pull-up Current <sup>4</sup> $V_{in} = V_{IL}$ DATA[15:0] $V_{in} = V_{IH}$ DATA[15:0]	$I_{MSP}$	— -15	-120 —	$\mu\text{A}$
12A	MC68336 $V_{DD}$ Supply Current <sup>5</sup> RUN <sup>6</sup> RUN, TPU emulation mode LPSTOP, 4.194 MHz crystal, VCO Off (STSIM = 0) LPSTOP (External clock input frequency = maximum $f_{sys}$ )	$I_{DD}$ $I_{DD}$ $S_{IDD}$ $S_{IDD}$	— — — —	140 150 3 7	mA mA mA mA
12B	MC68376 $V_{DD}$ Supply Current <sup>5</sup> RUN <sup>6</sup> RUN, TPU emulation mode LPSTOP, 4.194 MHz crystal, VCO Off (STSIM = 0) LPSTOP (External clock input frequency = maximum $f_{sys}$ )	$I_{DD}$ $I_{DD}$ $S_{IDD}$ $S_{IDD}$	— — — —	150 160 3 7	mA mA mA mA
13	Clock Synthesizer Operating Voltage	$V_{DDSYN}$	4.75	5.25	V
14	$V_{DDSYN}$ Supply Current <sup>5</sup> 4.194 MHz crystal, VCO on, maximum $f_{sys}$ External Clock, maximum $f_{sys}$ LPSTOP, 4.194 MHz crystal, VCO off (STSIM = 0) 4.194 MHz crystal, $V_{DD}$ powered down	$I_{DDSYN}$ $I_{DDSYN}$ $S_{IDDSYN}$ $I_{DDSYN}$	— — — —	3 5 3 3	mA mA mA mA



**Table A-5 DC Characteristics (Continued)**

( $V_{DD}$  and  $V_{DSSYN} = 5.0 \text{ Vdc} \pm 5\%$ ,  $V_{SS} = 0 \text{ Vdc}$ ,  $T_A = T_L$  to  $T_H$ )

Num	Characteristic	Symbol	Min	Max	Unit
15	RAM Standby Voltage <sup>7</sup> Specified $V_{DD}$ applied $V_{DD} = V_{SS}$	$V_{SB}$	0.0 3.0	5.25 5.25	V
16	RAM Standby Current <sup>5, 7, 8</sup> Normal RAM operation $V_{DD} > V_{SB} - 0.5 \text{ V}$ Transient condition $V_{SB} - 0.5 \text{ V} \geq V_{DD} \geq V_{SS} + 0.5 \text{ V}$ Standby operation $V_{DD} < V_{SS} + 0.5 \text{ V}$	$I_{SB}$	— — —	10 3 100	$\mu\text{A}$ mA $\mu\text{A}$
17A	MC68336 Power Dissipation <sup>9</sup>	$P_D$	—	756	mW
17B	MC68376 Power Dissipation <sup>9</sup>	$P_D$	—	809	mW
18	Input Capacitance <sup>2, 10</sup> All input-only pins All input/output pins	$C_{in}$	— —	10 20	pF
19	Load Capacitance <sup>2</sup> Group 1 I/O Pins and CLKOUT, FREEZE/QUOT, IPIPE Group 2 I/O Pins and CSBOOT, BG/CS Group 3 I/O pins Group 4 I/O pins	$C_L$	— — — —	90 100 130 200	pF

NOTES:

1. Applies to :

Port E[7:4] — SIZ[1:0],  $\overline{AS}$ ,  $\overline{DS}$   
Port F[7:0] —  $\overline{IRQ}$ [7:1], MODCLK  
Port QS[7:0] — TXD, PCS[3:1], PCS0/ $\overline{SS}$ , SCK, MOSI, MISO  
TPUCH[15:0], T2CLK, CPWM[8:5], CTD[4:3], CTD[10:9], CTM2C  
 $\overline{BKPT}$ / $\overline{DSCLK}$ ,  $\overline{IFETCH}$ ,  $\overline{RESET}$ , RXD,  $\overline{TSTME/TSC}$   
EXTAL (when PLL enabled)

2. Input-Only Pins: EXTAL,  $\overline{TSTME/TSC}$ ,  $\overline{BKPT}$ , PAI, T2CLK, RXD, CTM2C

Output-Only Pins: CSBOOT,  $\overline{BG/CS}$ , CLKOUT, FREEZE/QUOT,  $\overline{IPIPE}$

Input/Output Pins:

Group 1: DATA[15:0],  $\overline{IFETCH}$ , TPUCH[15:0], CPWM[8:5], CTD[4:3], CTD[10:9]

Group 2: Port C[6:0] — ADDR[22:19]/ $\overline{CS}$ [9:6], FC[2:0]/ $\overline{CS}$ [5:3]

Port E[7:0] — SIZ[1:0],  $\overline{AS}$ ,  $\overline{DS}$ ,  $\overline{AVEC}$ , RMC,  $\overline{DSACK}$ [1:0]

Port F[7:0] —  $\overline{IRQ}$ [7:1], MODCLK

Port QS[7:3] — TXD, PCS[3:1], PCS0/ $\overline{SS}$

ADDR23/ $\overline{CS10/ECLK}$ , ADDR[18:0], R/ $\overline{W}$ , BERR,  $\overline{BR/CS0}$ ,  $\overline{BGACK/CS2}$

Group 3: HALT, RESET

Group 4: MISO, MOSI, SCK

Pin groups do not include QADC pins. See **Tables A-11** through **A-14** for information concerning the QADC.

3. Does not apply to HALT and RESET because they are open drain pins. Does not apply to port QS[7:0] (TXD, PCS[3:1], PCS0/ $\overline{SS}$ , SCK, MOSI, MISO) in wired-OR mode.

4. Use of an active pull-down device is recommended.

5. Total operating current is the sum of the appropriate  $I_{DD}$ ,  $I_{DDSYN}$ , and  $I_{SB}$  values.  $I_{DD}$  values include supply currents for device modules powered by  $V_{DDE}$  and  $V_{DDI}$  pins.

6. Current measured at maximum system clock frequency, all modules active.

7. The SRAM module will not switch into standby mode as long as  $V_{SB}$  does not exceed  $V_{DD}$  by more than 0.5 volts. The SRAM array cannot be accessed while the module is in standby mode.

8. When  $V_{DD}$  is transitioning during power-up or power down sequence, and  $V_{SB}$  is applied, current flows between the  $V_{STBY}$  and  $V_{DD}$  pins, which causes standby current to increase toward the maximum transient condition specification. System noise on the  $V_{DD}$  and  $V_{STBY}$  pins can contribute to this condition.

9. Power dissipation measured at system clock frequency, all modules active. Power dissipation can be calculated using the following expression:

$$P_D = \text{Maximum } V_{DD} (\text{Run } I_{DD} + I_{DDSYN} + I_{SB}) + \text{Maximum } V_{DDA} (I_{DDA})$$

10. This parameter is periodically sampled rather than 100% tested.

**Table A-6 AC Timing**

( $V_{DD}$  and  $V_{DSSYN} = 5.0 \text{ Vdc} \pm 5\%$ ,  $V_{SS} = 0 \text{ Vdc}$ ,  $T_A = T_L$  to  $T_H$ )<sup>1</sup>

Num	Characteristic	Symbol	Min	Max	Unit
F1	Frequency of Operation <sup>2</sup>	$f_{sys}$	—	20.97	MHz
1	Clock Period	$t_{cyc}$	47.7	—	ns
1A	ECLK Period	$t_{E cyc}$	381	—	ns
1B	External Clock Input Period <sup>3</sup>	$t_{X cyc}$	47.7	—	ns
2, 3	Clock Pulse Width	$t_{CW}$	18.8	—	ns
2A, 3A	ECLK Pulse Width	$t_{ECW}$	183	—	ns
2B, 3B	External Clock Input High/Low Time <sup>3</sup>	$t_{XCHL}$	23.8	—	ns
3, 4	Clock Rise and Fall Time	$t_{Crf}$	—	5	ns
4A, 5A	Rise and Fall Time — All Outputs except CLKOUT	$t_{rf}$	—	8	ns
4B, 5B	External Clock Rise and Fall Time <sup>4</sup>	$t_{XCrf}$	—	5	ns
4	Clock High to Address, FC, SIZE, RMC Valid	$t_{CHAV}$	0	23	ns
5	Clock High to Address, Data, FC, SIZE, RMC High Impedance	$t_{CHAZx}$	0	47	ns
6	Clock High to Address, FC, SIZE, RMC Invalid <sup>5</sup>	$t_{CHAZn}$	0	—	ns
7	Clock Low to $\overline{AS}$ , $\overline{DS}$ , $\overline{CS}$ Asserted	$t_{CLSA}$	0	23	ns
8A	$\overline{AS}$ to $\overline{DS}$ or $\overline{CS}$ Asserted (Read) <sup>6</sup>	$t_{STSA}$	-10	10	ns
8C	Clock Low to IFETCH, IPIPE Asserted	$t_{CLIA}$	2	22	ns
11	Address, FC, SIZE, RMC Valid to $\overline{AS}$ , $\overline{CS}$ Asserted	$t_{AVSA}$	10	—	ns
12	Clock Low to $\overline{AS}$ , $\overline{DS}$ , $\overline{CS}$ Negated	$t_{CLSN}$	2	23	ns
12A	Clock Low to IFETCH, IPIPE Negated	$t_{CLIN}$	2	22	ns
13	$\overline{AS}$ , $\overline{DS}$ , $\overline{CS}$ Negated to Address, FC, SIZE Invalid (Address Hold)	$t_{SNAI}$	10	—	ns
14	$\overline{AS}$ , $\overline{CS}$ Width Asserted	$t_{SWA}$	80	—	ns
14A	$\overline{DS}$ , $\overline{CS}$ Width Asserted (Write)	$t_{SWAW}$	36	—	ns
14B	$\overline{AS}$ , $\overline{CS}$ Width Asserted (Fast Write Cycle)	$t_{SWDW}$	32	—	ns
15	$\overline{AS}$ , $\overline{DS}$ , $\overline{CS}$ Width Negated <sup>7</sup>	$t_{SN}$	32	—	ns
16	Clock High to $\overline{AS}$ , $\overline{DS}$ , $R/\overline{W}$ High Impedance	$t_{CHSZ}$	—	47	ns
17	$\overline{AS}$ , $\overline{DS}$ , $\overline{CS}$ Negated to $R/\overline{W}$ Negated	$t_{SNRN}$	10	—	ns
18	Clock High to $R/\overline{W}$ High	$t_{CHRH}$	0	23	ns
20	Clock High to $R/\overline{W}$ Low	$t_{CHRL}$	0	23	ns
21	$R/\overline{W}$ Asserted to $\overline{AS}$ , $\overline{CS}$ Asserted	$t_{RAAA}$	10	—	ns
22	$R/\overline{W}$ Low to $\overline{DS}$ , $\overline{CS}$ Asserted (Write)	$t_{RASA}$	54	—	ns
23	Clock High to Data Out Valid	$t_{CHDO}$	—	23	ns
24	Data Out Valid to Negating Edge of $\overline{AS}$ , $\overline{CS}$	$t_{DVASN}$	10	—	ns
25	$\overline{DS}$ , $\overline{CS}$ Negated to Data Out Invalid (Data Out Hold)	$t_{SNDI}$	10	—	ns

**Table A-6 AC Timing (Continued)** $(V_{DD}$  and  $V_{DDSYN} = 5.0$  Vdc  $\pm 5\%$ ,  $V_{SS} = 0$  Vdc,  $T_A = T_L$  to  $T_H$ )<sup>1</sup>

Num	Characteristic	Symbol	Min	Max	Unit
26	Data Out Valid to $\overline{DS}$ , $\overline{CS}$ Asserted (Write)	$t_{DVSA}$	10	—	ns
27	Data In Valid to Clock Low (Data Setup) <sup>5</sup>	$t_{DICL}$	5	—	ns
27A	Late $\overline{BERR}$ , $\overline{HALT}$ Asserted to Clock Low (Setup Time)	$t_{BELCL}$	15	—	ns
28	$\overline{AS}$ , $\overline{DS}$ Negated to $\overline{DSACK}[1:0]$ , $\overline{BERR}$ , $\overline{HALT}$ , $\overline{AVEC}$ Negated	$t_{SNDN}$	0	60	ns
29	$\overline{DS}$ , $\overline{CS}$ Negated to Data In Invalid (Data In Hold) <sup>8</sup>	$t_{SNDI}$	0	—	ns
29A	$\overline{DS}$ , $\overline{CS}$ Negated to Data In High Impedance <sup>8, 9</sup>	$t_{SHDI}$	—	48	ns
30	CLKOUT Low to Data In Invalid (Fast Cycle Hold) <sup>8</sup>	$t_{CLDI}$	10	—	ns
30A	CLKOUT Low to Data In High Impedance <sup>8</sup>	$t_{CLDH}$	—	72	ns
31	$\overline{DSACK}[1:0]$ Asserted to Data In Valid <sup>10</sup>	$t_{DADI}$	—	46	ns
33	Clock Low to $\overline{BG}$ Asserted/Negated	$t_{CLBAN}$	—	23	ns
35	$\overline{BR}$ Asserted to $\overline{BG}$ Asserted (RMC Not Asserted) <sup>11</sup>	$t_{BRAGA}$	1	—	$t_{cyc}$
37	$\overline{BGACK}$ Asserted to $\overline{BG}$ Negated	$t_{GAGN}$	1	2	$t_{cyc}$
39	$\overline{BG}$ Width Negated	$t_{GH}$	2	—	$t_{cyc}$
39A	$\overline{BG}$ Width Asserted	$t_{GA}$	1	—	$t_{cyc}$
46	$R/\overline{W}$ Width Asserted (Write or Read)	$t_{RWA}$	115	—	ns
46A	$R/\overline{W}$ Width Asserted (Fast Write or Read Cycle)	$t_{RWAS}$	70	—	ns
47A	Asynchronous Input Setup Time $\overline{BR}$ , $\overline{BGACK}$ , $\overline{DSACK}[1:0]$ , $\overline{BERR}$ , $\overline{AVEC}$ , $\overline{HALT}$	$t_{AIST}$	5	—	ns
47B	Asynchronous Input Hold Time	$t_{AIHT}$	12	—	ns
48	$\overline{DSACK}[1:0]$ Asserted to $\overline{BERR}$ , $\overline{HALT}$ Asserted <sup>12</sup>	$t_{DABA}$	—	30	ns
53	Data Out Hold from Clock High	$t_{DOCH}$	0	—	ns
54	Clock High to Data Out High Impedance	$t_{CHDH}$	—	23	ns
55	$R/\overline{W}$ Asserted to Data Bus Impedance Change	$t_{RADC}$	32	—	ns
56	$\overline{RESET}$ Pulse Width (Reset Instruction)	$t_{HRPW}$	512	—	$t_{cyc}$
57	$\overline{BERR}$ Negated to $\overline{HALT}$ Negated (Rerun)	$t_{BNHN}$	0	—	ns
70	Clock Low to Data Bus Driven (Show)	$t_{SCLDD}$	0	23	ns
71	Data Setup Time to Clock Low (Show)	$t_{SCLDS}$	10	—	ns
72	Data Hold from Clock Low (Show)	$t_{SCLDH}$	10	—	ns
73	$\overline{BKPT}$ Input Setup Time	$t_{BKST}$	10	—	ns
74	$\overline{BKPT}$ Input Hold Time	$t_{BKHT}$	10	—	ns
75	Mode Select Setup Time	$t_{MSS}$	20	—	$t_{cyc}$

**Table A-6 AC Timing (Continued)**

( $V_{DD}$  and  $V_{DSSYN} = 5.0 \text{ Vdc} \pm 5\%$ ,  $V_{SS} = 0 \text{ Vdc}$ ,  $T_A = T_L$  to  $T_H$ )<sup>1</sup>

Num	Characteristic	Symbol	Min	Max	Unit
76	Mode Select Hold Time	$t_{MSH}$	0	—	ns
77	$\overline{\text{RESET}}$ Assertion Time <sup>13</sup>	$t_{RSTA}$	4	—	$t_{cyc}$
78	$\overline{\text{RESET}}$ Rise Time <sup>14, 15</sup>	$t_{RSTR}$	—	10	$t_{cyc}$

NOTES:

- All AC timing is shown with respect to 20%  $V_{DD}$  and 70%  $V_{DD}$  levels unless otherwise noted.
- The base configuration of the MC68336/376 requires a 20.97 MHz crystal reference.
- When an external clock is used, minimum high and low times are based on a 50% duty cycle. The minimum allowable  $t_{Xcyc}$  period is reduced when the duty cycle of the external clock signal varies. The relationship between external clock input duty cycle and minimum  $t_{Xcyc}$  is expressed:  
Minimum  $t_{Xcyc}$  period = minimum  $t_{XCHL} / (50\% - \text{external clock input duty cycle tolerance})$ .
- Parameters for an external clock signal applied while the internal PLL is disabled (MODCLK pin held low during reset). Does not pertain to an external VCO reference applied while the PLL is enabled (MODCLK pin held high during reset). When the PLL is enabled, the clock synthesizer detects successive transitions of the reference signal. If transitions occur within the correct clock period, rise/fall times and duty cycle are not critical.
- Address access time =  $(2.5 + WS) t_{cyc} - t_{CHAV} - t_{DICL}$   
Chip select access time =  $(2 + WS) t_{cyc} - t_{LSA} - t_{DICL}$   
Where: WS = number of wait states. When fast termination is used (2 clock bus) WS = -1.
- Specification 9A is the worst-case skew between  $\overline{\text{AS}}$  and  $\overline{\text{DS}}$  or  $\overline{\text{CS}}$ . The amount of skew depends on the relative loading of these signals. When loads are kept within specified limits, skew will not cause  $\overline{\text{AS}}$  and  $\overline{\text{DS}}$  to fall outside the limits shown in specification 9.
- If multiple chip selects are used,  $\overline{\text{CS}}$  width negated (specification 15) applies to the time from the negation of a heavily loaded chip select to the assertion of a lightly loaded chip select. The  $\overline{\text{CS}}$  width negated specification between multiple chip selects does not apply to chip selects being used for synchronous ECLK cycles.
- Hold times are specified with respect to  $\overline{\text{DS}}$  or  $\overline{\text{CS}}$  on asynchronous reads and with respect to CLKOUT on fast cycle reads. The user is free to use either hold time.
- Maximum value is equal to  $(t_{cyc} / 2) + 25 \text{ ns}$ .
- If the asynchronous setup time (specification 47A) requirements are satisfied, the  $\overline{\text{DSACK}}[1:0]$  low to data setup time (specification 31) and  $\overline{\text{DSACK}}[1:0]$  low to  $\overline{\text{BERR}}$  low setup time (specification 48) can be ignored. The data must only satisfy the data-in to clock low setup time (specification 27) for the following clock cycle.  $\overline{\text{BERR}}$  must satisfy only the late  $\overline{\text{BERR}}$  low to clock low setup time (specification 27A) for the following clock cycle.
- To ensure coherency during every operand transfer,  $\overline{\text{BG}}$  will not be asserted in response to  $\overline{\text{BR}}$  until after all cycles of the current operand transfer are complete and  $\overline{\text{RMC}}$  is negated.
- In the absence of  $\overline{\text{DSACK}}[1:0]$ ,  $\overline{\text{BERR}}$  is an asynchronous input using the asynchronous setup time (specification 47A).
- After external  $\overline{\text{RESET}}$  negation is detected, a short transition period (approximately  $2 t_{cyc}$ ) elapses, then the SIM drives  $\overline{\text{RESET}}$  low for  $512 t_{cyc}$ .
- External assertion of the  $\overline{\text{RESET}}$  input can overlap internally-generated resets. To insure that an external reset is recognized in all cases,  $\overline{\text{RESET}}$  must be asserted for at least 590 CLKOUT cycles.
- External logic must pull  $\overline{\text{RESET}}$  high during this period in order for normal MCU operation to begin.

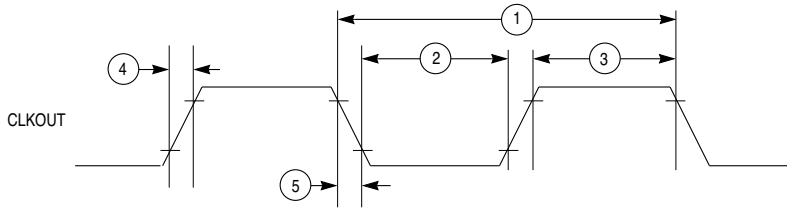

68300 CLKOUT TIM

**Figure A-1 CLKOUT Output Timing Diagram**

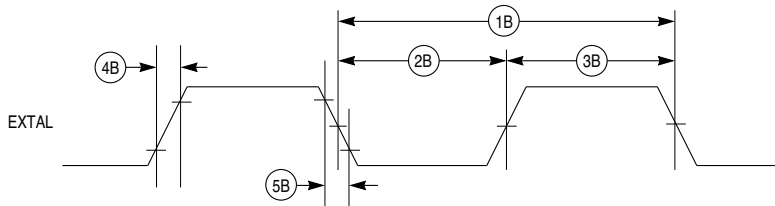

NOTE: TIMING SHOWN WITH RESPECT TO 20% AND 70%  $V_{DD}$ .  
PULSE WIDTH SHOWN WITH RESPECT TO 50%  $V_{DD}$ .

68300 EXT CLK INPUT TIM

**Figure A-2 External Clock Input Timing Diagram**

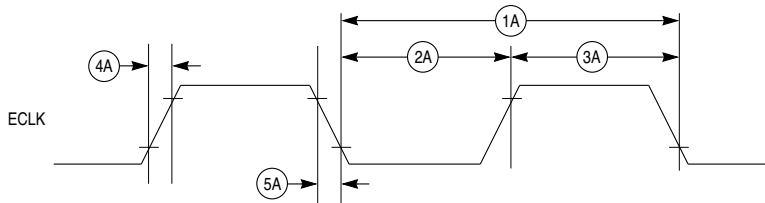

NOTE: TIMING SHOWN WITH RESPECT TO 20% AND 70%  $V_{DD}$ .

68300 ECLK OUTPUT TIM

**Figure A-3 ECLK Output Timing Diagram**

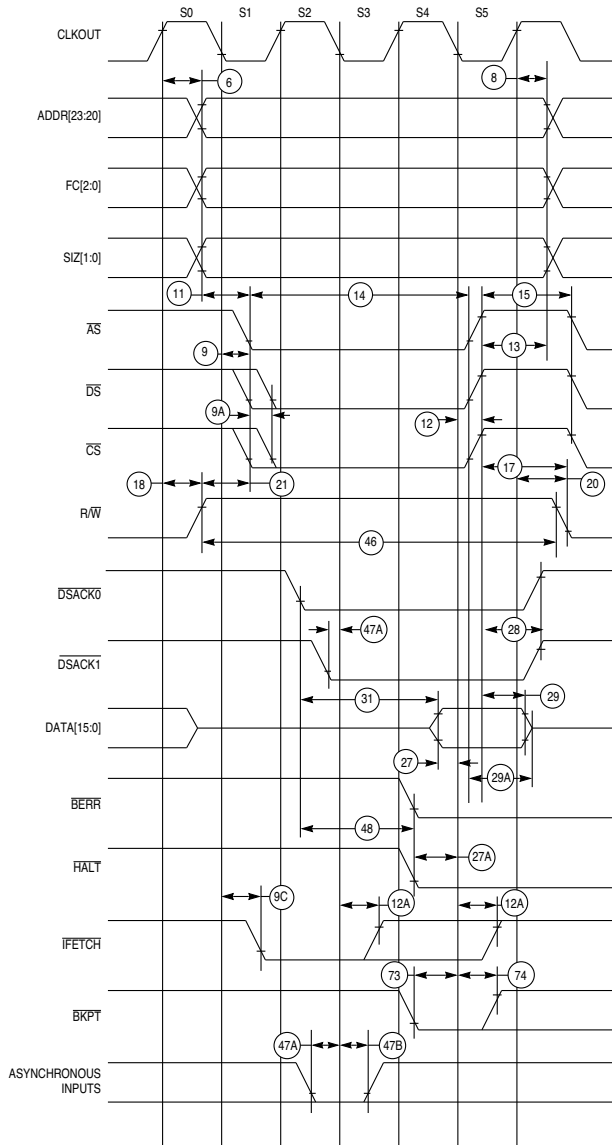

68300 RD CYC TIM

**Figure A-4 Read Cycle Timing Diagram**

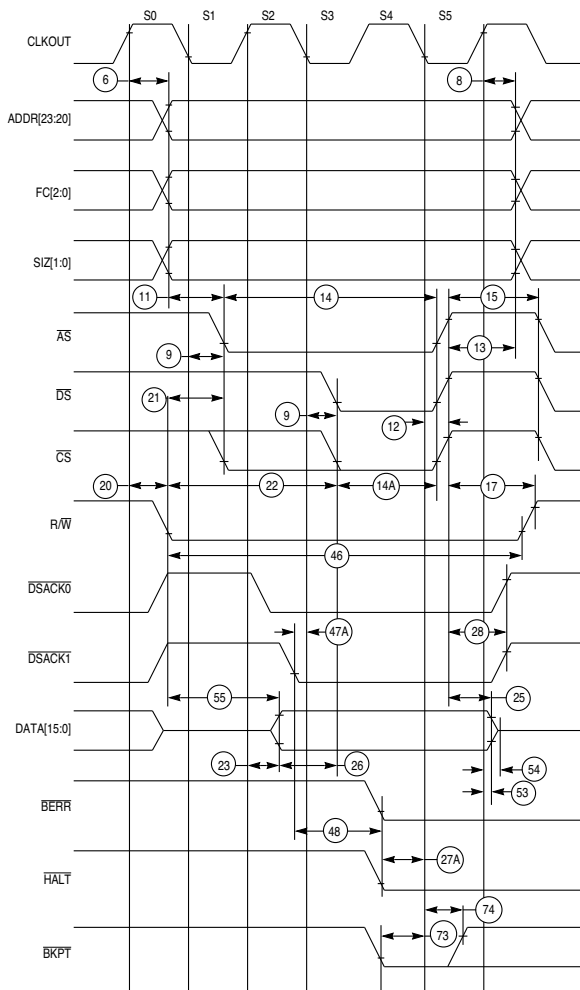

68300 WR CYC TIM

**Figure A-5 Write Cycle Timing Diagram**



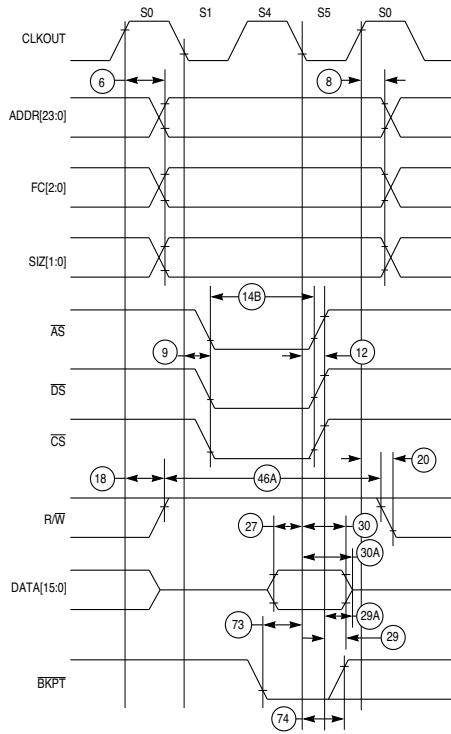

68300 FAST RD CYC TIM

**Figure A-6 Fast Termination Read Cycle Timing Diagram**

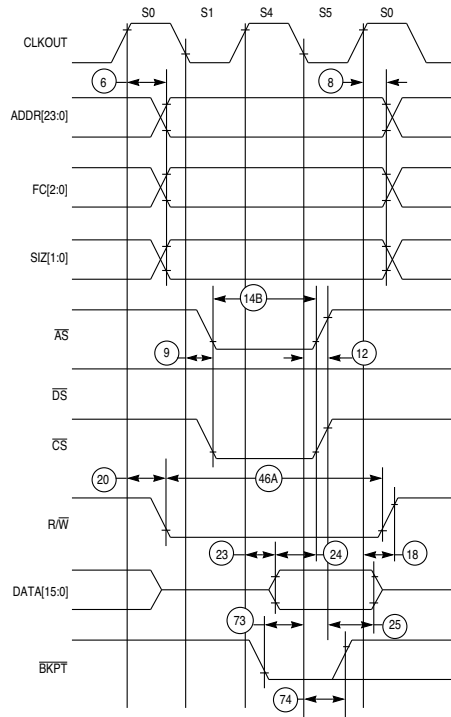

68300 FAST WR CYC TIM

**Figure A-7 Fast Termination Write Cycle Timing Diagram**

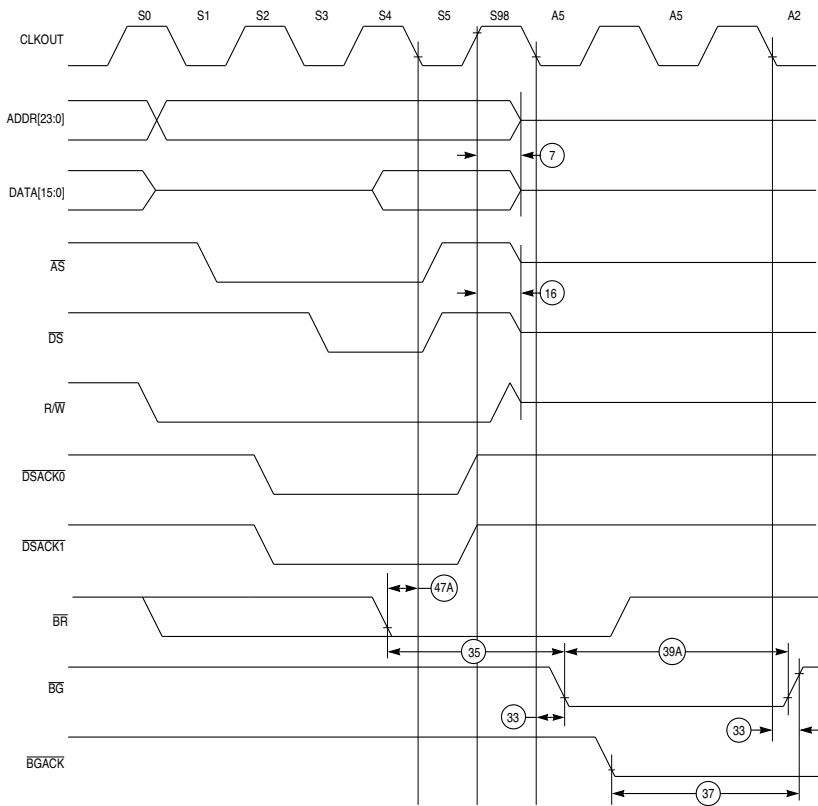

68300 BUS ARB TIM

**Figure A-8 Bus Arbitration Timing Diagram — Active Bus Case**

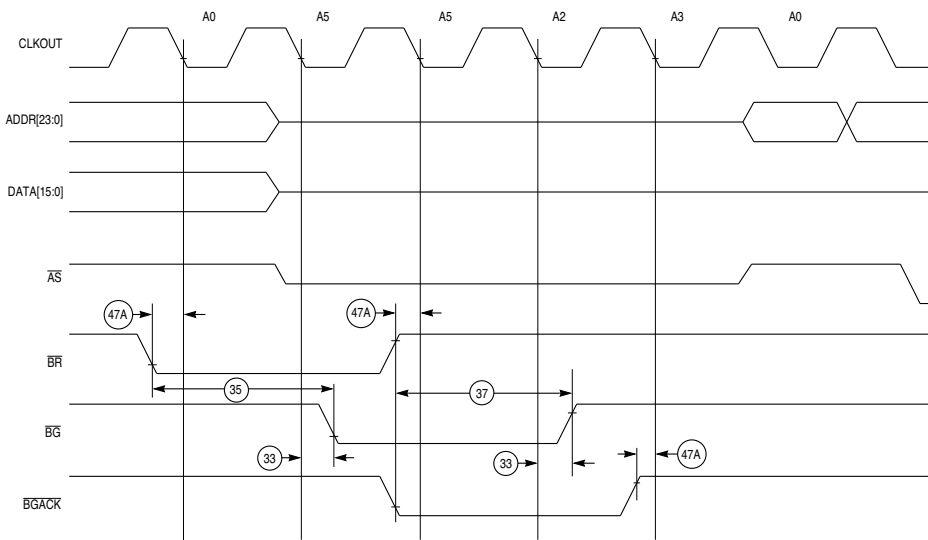

68300 BUS ARB TIM IDLE

**Figure A-9 Bus Arbitration Timing Diagram — Idle Bus Case**

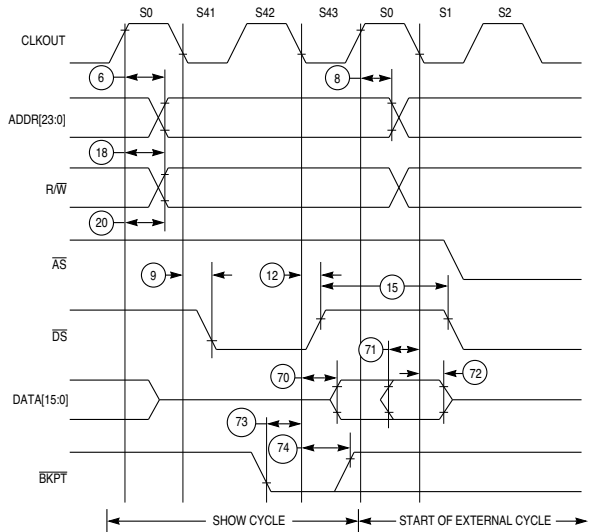

**NOTE:**  
 Show cycles can stretch during clock phase S42 when bus accesses take longer than two cycles due to IMB module wait-state insertion.

68300 SHW CYC TIM

**Figure A-10 Show Cycle Timing Diagram**

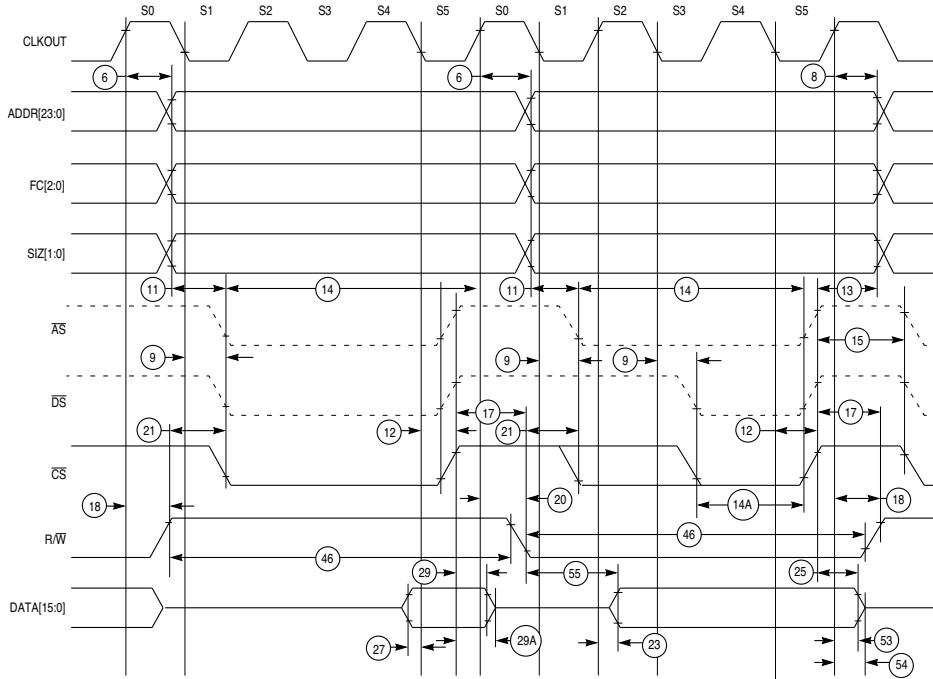

68300 CHIP SEL TIM

**Figure A-11 Chip-Select Timing Diagram**

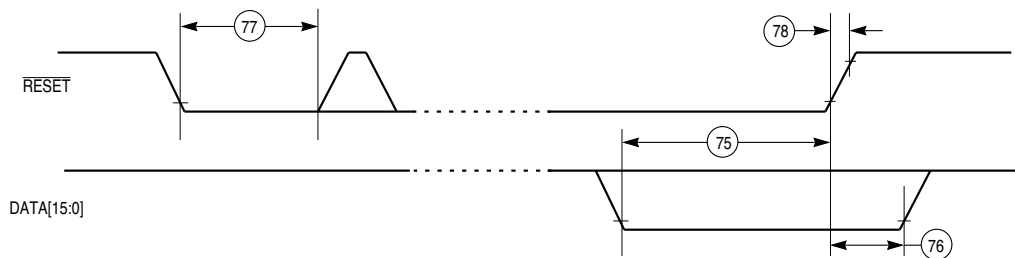

68300 RST/MODE SEL TIM

**Figure A-12 Reset and Mode Select Timing Diagram**

**Table A-7 Background Debug Mode Timing** $(V_{DD} = 5.0 \text{ Vdc} \pm 5\%, V_{SS} = 0 \text{ Vdc}, T_A = T_L \text{ to } T_H)^1$ 

Num	Characteristic	Symbol	Min	Max	Unit
B0	DSI Input Setup Time	$t_{DSISU}$	15	—	ns
B1	DSI Input Hold Time	$t_{DSIH}$	10	—	ns
B2	DSCLK Setup Time	$t_{DSCSU}$	15	—	ns
B3	DSCLK Hold Time	$t_{DSCH}$	10	—	ns
B4	DSO Delay Time	$t_{DSOD}$	—	25	ns
B5	DSCLK Cycle Time	$t_{DSCCYC}$	2	—	$t_{cyc}$
B6	CLKOUT Low to FREEZE Asserted/Negated	$t_{FRZAN}$	—	50	ns
B7	CLKOUT High to $\overline{\text{IFETCH}}$ High Impedance	$t_{IPZ}$	—	TBD	ns
B8	CLKOUT High to $\overline{\text{IFETCH}}$ Valid	$t_{IP}$	—	TBD	ns
B9	DSCLK Low Time	$t_{DSCLO}$	1	—	$t_{cyc}$

**NOTES:**

1. All AC timing is shown with respect to 20%  $V_{DD}$  and 70%  $V_{DD}$  levels unless otherwise noted.

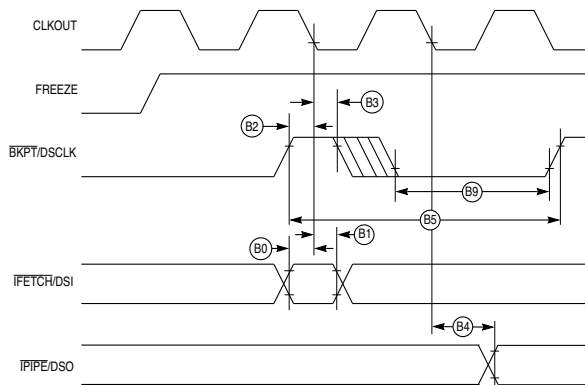

68300 BKGD DBM SER COM TIM

**Figure A-13 Background Debugging Mode Timing — Serial Communication**

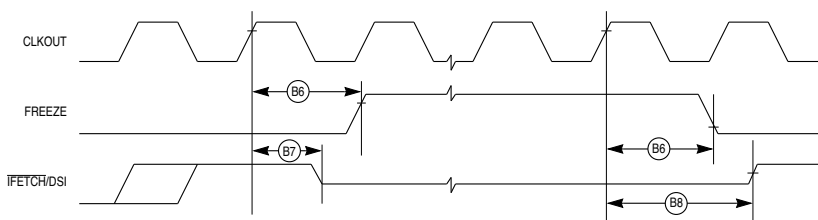

68300 BDM FRZ TIM

**Figure A-14 Background Debugging Mode Timing — Freeze Assertion**

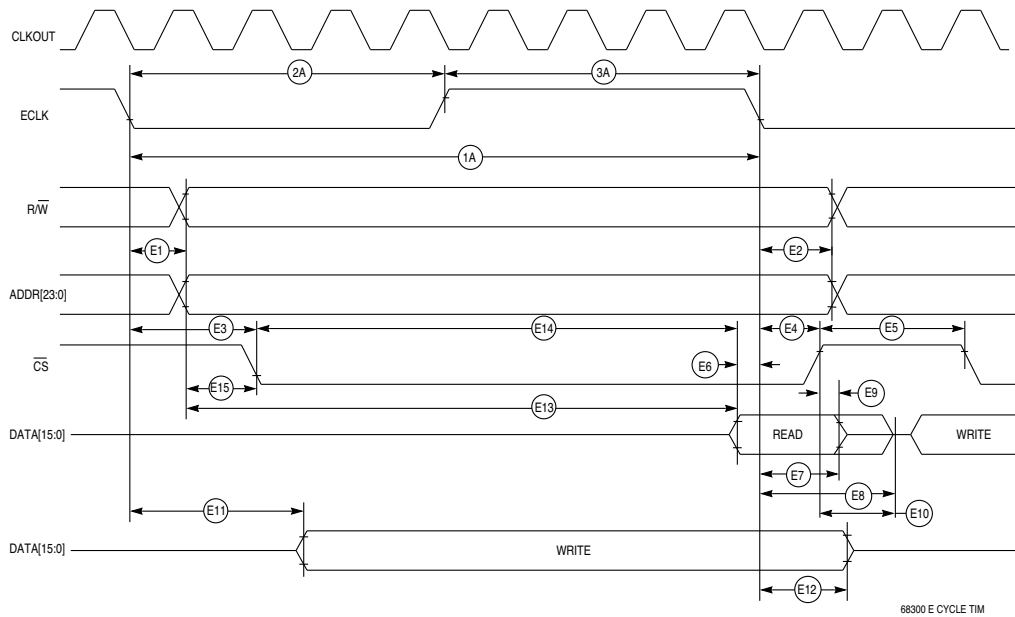

**Table A-8 ECLK Bus Timing** $(V_{DD} = 5.0 \text{ Vdc} \pm 5\%, V_{SS} = 0 \text{ Vdc}, T_A = T_L \text{ to } T_H)^1$ 

Num	Characteristic	Symbol	Min	Max	Unit
E1	ECLK Low to Address Valid <sup>2</sup>	$t_{EAD}$	—	48	ns
E2	ECLK Low to Address Hold	$t_{EAH}$	10	—	ns
E3	ECLK Low to $\overline{CS}$ Valid ( $\overline{CS}$ delay)	$t_{ECSD}$	—	120	ns
E4	ECLK Low to $\overline{CS}$ Hold	$t_{ECSH}$	10	—	ns
E5	$\overline{CS}$ Negated Width	$t_{ECSN}$	25	—	ns
E6	Read Data Setup Time	$t_{EDSR}$	25	—	ns
E7	Read Data Hold Time	$t_{EDHR}$	5	—	ns
E8	ECLK Low to Data High Impedance	$t_{EDHZ}$	—	48	ns
E9	$\overline{CS}$ Negated to Data Hold (Read)	$t_{ECDH}$	0	—	ns
E10	$\overline{CS}$ Negated to Data High Impedance	$t_{ECDZ}$	—	1	$t_{cyc}$
E11	ECLK Low to Data Valid (Write)	$t_{EDDW}$	—	2	$t_{cyc}$
E12	ECLK Low to Data Hold (Write)	$t_{EDHW}$	10	—	ns
E13	Address Access Time (Read) <sup>3</sup>	$t_{EACC}$	308	—	ns
E14	Chip Select Access Time (Read) <sup>4</sup>	$t_{EACS}$	236	—	ns
E15	Address Setup Time	$t_{EAS}$	1/2	—	$t_{cyc}$

**NOTES:**

1. All AC timing is shown with respect to 20%  $V_{DD}$  and 70%  $V_{DD}$  levels unless otherwise noted.
2. When the previous bus cycle is not an ECLK cycle, the address may be valid before ECLK goes low.
3. Address access time =  $t_{E_{cyc}} - t_{EAD} - t_{EDSR}$ .
4. Chip select access time =  $t_{E_{cyc}} - t_{ECSD} - t_{EDSR}$ .



**Figure A-15 ECLK Timing Diagram**

### Table A-9 QSPI Timing

( $V_{DD}$  and  $V_{DDSYN} = 5.0 \text{ Vdc} \pm 5\%$ ,  $V_{SS} = 0 \text{ Vdc}$ ,  $T_A = T_L$  to  $T_H$ , 200 pF load on all QSPI pins)<sup>1</sup>

Num	Function	Symbol	Min	Max	Unit
1	Operating Frequency Master Slave	$f_{QSPI}$	DC DC	1/4 1/4	$f_{sys}$ $f_{sys}$
2	Cycle Time Master Slave	$t_{qcyt}$	4 4	510 —	$t_{cyc}$ $t_{cyc}$
3	Enable Lead Time Master Slave	$t_{lead}$	2 2	128 —	$t_{cyc}$ $t_{cyc}$
4	Enable Lag Time Master Slave	$t_{lag}$	— 2	1/2 —	SCK $t_{cyc}$
5	Clock (SCK) High or Low Time Master Slave <sup>2</sup>	$t_{sw}$	$2 t_{cyc} - 60$ $2 t_{cyc} - n$	$255 t_{cyc}$ —	ns ns
6	Sequential Transfer Delay Master Slave (Does Not Require Deselect)	$t_{td}$	17 13	8192 —	$t_{cyc}$ $t_{cyc}$
7	Data Setup Time (Inputs) Master Slave	$t_{su}$	30 20	— —	ns ns
8	Data Hold Time (Inputs) Master Slave	$t_{hi}$	0 20	— —	ns ns
9	Slave Access Time	$t_a$	—	1	$t_{cyc}$
10	Slave MISO Disable Time	$t_{dis}$	—	2	$t_{cyc}$
11	Data Valid (after SCK Edge) Master Slave	$t_v$	— —	50 50	ns ns
12	Data Hold Time (Outputs) Master Slave	$t_{ho}$	0 0	— —	ns ns
13	Rise Time Input Output	$t_{ri}$ $t_{ro}$	— —	2 30	$\mu\text{s}$ ns
14	Fall Time Input Output	$t_{fi}$ $t_{fo}$	— —	2 30	$\mu\text{s}$ ns

NOTES:

1. All AC timing is shown with respect to 20%  $V_{DD}$  and 70%  $V_{DD}$  levels unless otherwise noted.
2. For high time,  $n =$  External SCK rise time; for low time,  $n =$  External SCK fall time.

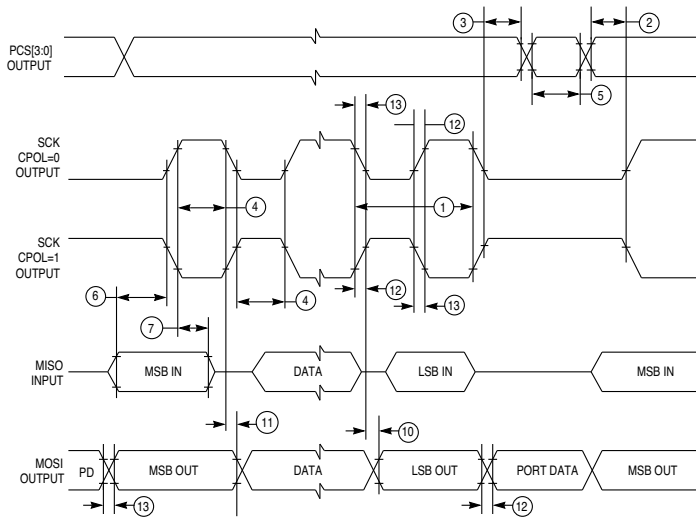

QSPI MAST CPHA0

**Figure A-16 QSPI Timing — Master, CPHA = 0**

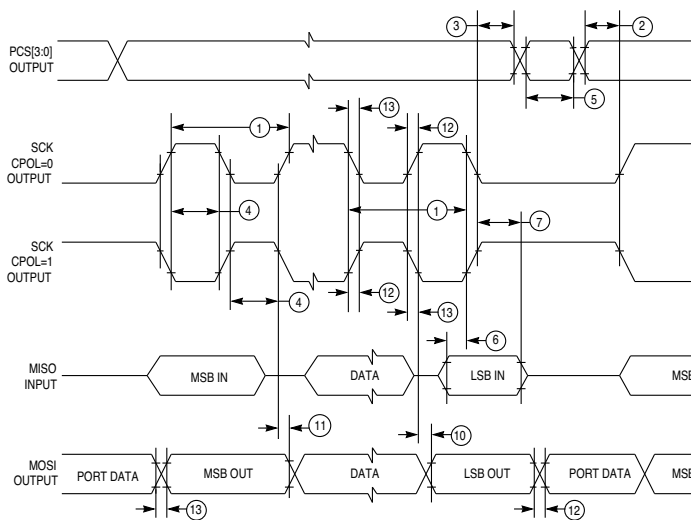

QSPI MAST CPHA1

**Figure A-17 QSPI Timing — Master, CPHA = 1**

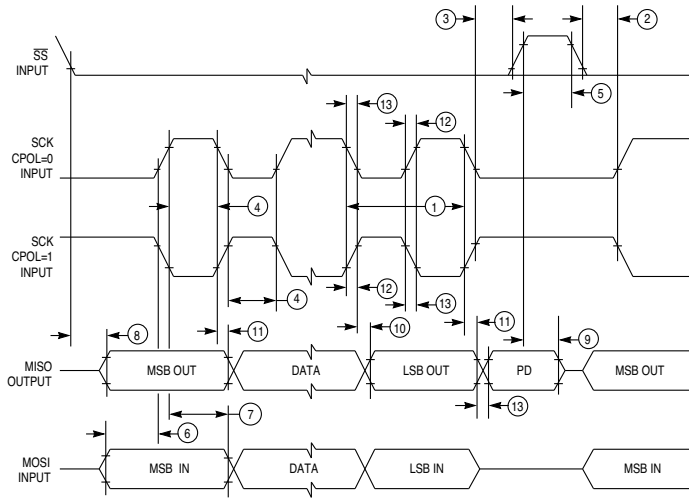

QSPI SLV CPHA0

**Figure A-18 QSPI Timing — Slave, CPHA = 0**

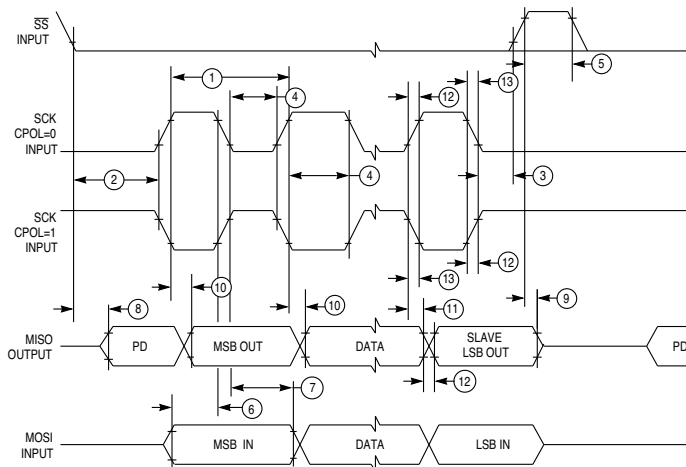

QSPI SLV CPHA1

**Figure A-19 QSPI Timing — Slave, CPHA = 1**

## Table A-10 Time Processor Unit Timing

( $V_{DD}$  and  $V_{DDSYN} = 5.0 \text{ Vdc} \pm 5\%$ ,  $V_{SS} = 0 \text{ Vdc}$ ,  $T_A = T_L$  to  $T_H$ ,  $f_{sys} = 20.97 \text{ MHz}$ )<sup>1, 2</sup>

Num	Rating	Symbol	Min	Max	Unit
1	CLKOUT High to TPU Output Channel Valid <sup>3, 4</sup>	$t_{CHTOV}$	2	18	ns
2	CLKOUT High to TPU Output Channel Hold	$t_{CHTOH}$	0	15	ns
3	TPU Input Channel Pulse Width	$t_{TIPW}$	4	—	$t_{cyc}$

### NOTES:

1. AC timing is shown with respect to 20%  $V_{DD}$  and 70%  $V_{DD}$  levels.
2. Timing not valid for external T2CLK input.
3. Maximum load capacitance for CLKOUT pin is 90 pF.
4. Maximum load capacitance for TPU output pins is 100 pF.

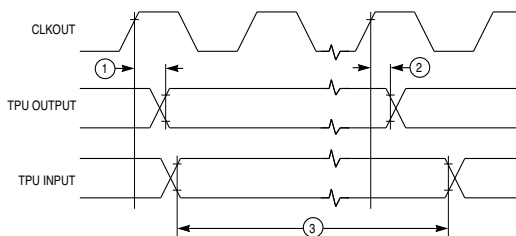

TPU I/O TIM

Figure A-20 TPU Timing Diagram

**Table A-11 QADC Maximum Ratings**

Num	Parameter	Symbol	Min	Max	Unit
1	Analog Supply, with reference to $V_{SSA}$	$V_{DDA}$	- 0.3	6.5	V
2	Internal Digital Supply, with reference to $V_{SSI}$	$V_{DDI}$	- 0.3	6.5	V
3	Reference Supply, with reference to $V_{RL}$	$V_{RH}$	- 0.3	6.5	V
4	$V_{SS}$ Differential Voltage	$V_{SSI} - V_{SSA}$	- 0.1	0.1	V
5	$V_{DD}$ Differential Voltage	$V_{DDI} - V_{DDA}$	- 6.5	6.5	V
6	$V_{REF}$ Differential Voltage	$V_{RH} - V_{RL}$	- 6.5	6.5	V
7	$V_{RH}$ to $V_{DDA}$ Differential Voltage	$V_{RH} - V_{DDA}$	- 6.5	6.5	V
8	$V_{RL}$ to $V_{SSA}$ Differential Voltage	$V_{RL} - V_{SSA}$	- 6.5	6.5	V
9	Disruptive Input Current <sup>1, 2, 3, 4, 5, 6, 7</sup> $V_{NEGCLAMP} = - 0.3$ V $V_{POSCLAMP} = 8$ V	$I_{NA}$	- 500	500	$\mu$ A
10	Positive Overvoltage Current Coupling Ratio <sup>1, 5, 6, 8</sup> PQA PQB	$K_P$	2000 2000	—	—
11	Negative Overvoltage Current Coupling Ratio <sup>1, 5, 6, 8</sup> PQA PQB	$K_N$	125 500	—	—
12	Maximum Input Current <sup>3, 4, 6</sup> $V_{NEGCLAMP} = - 0.3$ V $V_{POSCLAMP} = 8$ V	$I_{MA}$	- 25	25	mA

**NOTES:**

1. Below disruptive current conditions, the channel being stressed has conversion values of \$3FF for analog inputs greater than  $V_{RH}$  and \$000 for values less than  $V_{RL}$ . This assumes that  $V_{RH} \leq V_{DDA}$  and  $V_{RL} \geq V_{SSA}$  due to the presence of the sample amplifier. Other channels are not affected by non-disruptive conditions.
2. Input signals with large slew rates or high frequency noise components cannot be converted accurately. These signals also affect the conversion accuracy of other channels.
3. Exceeding limit may cause conversion error on stressed channels and on unstressed channels. Transitions within the limit do not affect device reliability or cause permanent damage.
4. Input must be current limited to the value specified. To determine the value of the required current-limiting resistor, calculate resistance values using positive and negative clamp values, then use the larger of the calculated values.
5. This parameter is periodically sampled rather than 100% tested.
6. Condition applies to one pin at a time.
7. Determination of actual maximum disruptive input current, which can affect operation, is related to external system component values.
8. Current coupling is the ratio of the current induced from overvoltage (positive or negative, through an external series coupling resistor), divided by the current induced on adjacent pins. A voltage drop may occur across the external source impedances of the adjacent pins, impacting conversions on these adjacent pins.

**Table A-12 QADC DC Electrical Characteristics (Operating)**

( $V_{SS}$  and  $V_{SSA} = 0V_{dc}$ ,  $f_{QCLK} = 2.1 \text{ MHz}$ ,  $T_A = T_L$  to  $T_H$ )

Num	Parameter	Symbol	Min	Max	Unit
1	Analog Supply <sup>1</sup>	$V_{DDA}$	4.5	5.5	V
2	Internal Digital Supply <sup>1</sup>	$V_{DDI}$	4.5	5.5	V
3	$V_{SS}$ Differential Voltage	$V_{SSI} - V_{SSA}$	-1.0	1.0	mV
4	$V_{DD}$ Differential Voltage	$V_{DDI} - V_{DDA}$	-1.0	1.0	V
5	Reference Voltage Low <sup>2</sup>	$V_{RL}$	$V_{SSA}$	—	V
6	Reference Voltage High <sup>2</sup>	$V_{RH}$	—	$V_{DDA}$	V
7	$V_{REF}$ Differential Voltage <sup>3</sup>	$V_{RH} - V_{RL}$	4.5	5.5	V
8	Mid-Analog Supply Voltage	$V_{DDA}/2$	2.25	2.75	V
9	Input Voltage	$V_{INDC}$	$V_{SSA}$	$V_{DDA}$	V
10	Input High Voltage, PQA and PQB	$V_{IH}$	$0.7 (V_{DDA})$	$V_{DDA} + 0.3$	V
11	Input Low Voltage, PQA and PQB	$V_{IL}$	$V_{SSA} - 0.3$	$0.2 (V_{DDA})$	V
12	Input Hysteresis <sup>4</sup>	$V_{HYS}$	0.5	—	V
13	Output Low Voltage, PQA <sup>5</sup> $I_{OL} = 5.3 \text{ mA}$ $I_{OL} = 10.0 \text{ } \mu\text{A}$	$V_{OL}$	— —	0.4 0.2	V
14	Analog Supply Current Normal Operation <sup>6</sup> Low-Power Stop	$I_{DDA}$	— —	1.0 10.0	mA $\mu\text{A}$
15	Reference Supply Current	$I_{REF}$	—	150	$\mu\text{A}$
16	Load Capacitance, PQA	$C_L$	—	90	pF
17	Input Current, Channel Off <sup>7</sup> PQA PQB	$I_{OFF}$	— —	250 150	nA
18	Total Input Capacitance <sup>8</sup> PQA Not Sampling PQA Sampling PQB Not Sampling PQB Sampling	$C_{IN}$	— — — —	15 20 10 15	pF

NOTES:

- Refers to operation over full temperature and frequency range.
- To obtain full-scale, full-range results,  $V_{SSA} \leq V_{RL} \leq V_{INDC} \leq V_{RH} \leq V_{DDA}$ .
- Accuracy tested and guaranteed at  $V_{RH} - V_{RL} = 5.0V \pm 10\%$ .
- Parameter applies to the following pins:  
Port A: PQA[7:0]/AN[59:58]/ETRIG[2:1]  
Port B: PQB[7:0]/AN[3:0]/AN[51:48]/AN[Z:W]
- Open drain only.
- Current measured at maximum system clock frequency with QADC active.
- Maximum leakage occurs at maximum operating temperature. Current decreases by approximately one-half for each 10° C decrease from maximum temperature.
- This parameter is periodically sampled rather than 100% tested.



**Table A-13 QADC AC Electrical Characteristics (Operating)** $(V_{DDI}$  and  $V_{DDA} = 5.0 \text{ Vdc} \pm 5\%$ ,  $V_{SSI}$  and  $V_{SSA} = 0\text{Vdc}$ ,  $T_A = T_L$  to  $T_H$ )

Num	Parameter	Symbol	Min	Max	Unit
1	QADC Clock (QCLK) Frequency <sup>1</sup>	$f_{\text{QCLK}}$	0.5	2.1	MHz
2	QADC Clock Duty Cycle <sup>2, 3</sup> High Phase Time ( $t_{\text{PSL}} \leq t_{\text{PSH}}$ )	$t_{\text{PSH}}$	500	—	ns
3	Conversion Cycles <sup>4</sup>	CC	18	32	QCLK cycles
4	Conversion Time <sup>2,4,5</sup> $f_{\text{QCLK}} = 0.999 \text{ MHz}^6$ Min = CCW/IST = %00 Max = CCW/IST = %11 $f_{\text{QCLK}} = 2.097 \text{ MHz}^{1, 7}$ Min = CCW/IST = %00 Max = CCW/IST = %11	$t_{\text{CONV}}$	18.0 8.58	32 15.24	$\mu\text{s}$
5	Stop Mode Recovery Time	$t_{\text{SR}}$	—	10	$\mu\text{s}$

## NOTES:

1. Conversion characteristics vary with  $f_{\text{QCLK}}$  rate. Reduced conversion accuracy occurs at max  $f_{\text{QCLK}}$  rate.
2. Duty cycle must be as close as possible to 75% to achieve optimum performance.
3. Minimum applies to 1.0 MHz operation.
4. Assumes that short input sample time has been selected (IST = 0).
5. Assumes that  $f_{\text{sys}} = 20.97 \text{ MHz}$ .
6. Assumes  $f_{\text{QCLK}} = 0.999 \text{ MHz}$ , with clock prescaler values of:  
QACR0: PSH = %01111, PSA = %1, PSL = 100)  
CCW: BYP = %0
7. Assumes  $f_{\text{QCLK}} = 2.097 \text{ MHz}$ , with clock prescaler values of:  
QACR0: PSH = %00110, PSA = %1, PSL = 010)  
CCW: BYP = %0

**Table A-14 QADC Conversion Characteristics (Operating)**

( $V_{DDI}$  and  $V_{DDA} = 5.0 \text{ Vdc} \pm 5\%$ ,  $V_{SSJ}$  and  $V_{SSA} = 0 \text{ Vdc}$ ,  $T_A = T_L$  to  $T_H$ ,  
 $0.5 \text{ MHz} \leq f_{QCLK} \leq 2.1 \text{ MHz}$ , 2 clock input sample time)

Num	Parameter	Symbol	Min	Typ	Max	Unit
1	Resolution <sup>1</sup>	1 Count	—	5	—	mV
2	Differential nonlinearity <sup>2</sup>	DNL	—	—	± 0.5	Counts
3	Integral nonlinearity	INL	—	—	± 2.0	Counts
4	Absolute error <sup>2, 3, 4</sup> $f_{QCLK} = 0.999 \text{ MHz}$ <sup>5</sup> PQA PQB $f_{QCLK} = 2.097 \text{ MHz}$ <sup>6</sup> PQA PQB	AE	— — — —	— — — —	± 2.5 ± 2.5 ± 4.0 ± 4.0	Counts
5	Source impedance at input <sup>7</sup>	$R_S$	—	20	—	k $\Omega$

NOTES:

- At  $V_{RH} - V_{RL} = 5.12 \text{ V}$ , one count = 5 mV.
- This parameter is periodically sampled rather than 100% tested.
- Absolute error includes 1/2 count (2.5 mV) of inherent quantization error and circuit (differential, integral, and offset) error. Specification assumes that adequate low-pass filtering is present on analog input pins — capacitive filter with 0.01  $\mu\text{F}$  to 0.1  $\mu\text{F}$  capacitor between analog input and analog ground, typical source isolation impedance of 20 k $\Omega$ .
- Assumes  $f_{sys} = 20.97 \text{ MHz}$ .
- Assumes clock prescaler values of:  
 QACR0: PSH = %01111, PSA = %1, PSL = 100  
 CCW: BYP = %0
- Assumes clock prescaler values of:  
 QACR0: PSH = %00110, PSA = %1, PSL = 010  
 CCW: BYP = %0
- Maximum source impedance is application-dependent. Error resulting from pin leakage depends on junction leakage into the pin and on leakage due to charge-sharing with internal capacitance. Error from junction leakage is a function of external source impedance and input leakage current. In the following expression, expected error in result value due to junction leakage is expressed in voltage ( $V_{errj}$ ):

$$V_{errj} = R_S \times I_{OFF}$$

where  $I_{OFF}$  is a function of operating temperature. Refer to **Table A-12**.

Charge-sharing leakage is a function of input source impedance, conversion rate, change in voltage between successive conversions, and the size of the decoupling capacitor used. Error levels are best determined empirically. In general, continuous conversion of the same channel may not be compatible with high source impedance.

**Table A-15 FCSM Timing Characteristics**

$$(V_{DD} = 5.0 \text{ Vdc} \pm 5\%, V_{SS} = 0 \text{ Vdc}, T_A = T_L \text{ to } T_H)$$

Num	Parameter	Symbol	Min	Max	Unit
1	Input pin frequency <sup>1</sup>	$f_{PCNTR}$	0	$f_{sys}/4$	MHz
2	Input pin low time	$t_{PINL}$	$2.0/f_{sys}$	—	$\mu\text{s}$
3	Input pin high time	$t_{PINH}$	$2.0/f_{sys}$	—	$\mu\text{s}$
4	Clock pin to counter increment	$t_{PINC}$	$4.5/f_{sys}$	$6.5/f_{sys}$	$\mu\text{s}$
5	Clock pin to new TBB value	$t_{PTBB}$	$5.0/f_{sys}$	$7.0/f_{sys}$	$\mu\text{s}$
6	Clock pin to COF set (\$FFFF)	$t_{PCOF}$	$4.5/f_{sys}$	$6.5/f_{sys}$	$\mu\text{s}$
7	Pin to IN bit delay	$t_{PINB}$	$1.5/f_{sys}$	$2.5/f_{sys}$	$\mu\text{s}$
8	Flag to IMB interrupt request	$t_{FIRQ}$	$1.0/f_{sys}$	$1.0/f_{sys}$	$\mu\text{s}$
9	Counter resolution <sup>2</sup>	$t_{CRES}$	—	$2.0/f_{sys}$	$\mu\text{s}$

## NOTES:

1. Value applies when using external clock.
2. Value applies when using internal clock. Minimum counter resolution depends on prescaler divide ratio selection.

**Table A-16 MCSM Timing Characteristics**

$$(V_{DD} = 5.0 \text{ Vdc} \pm 5\%, V_{SS} = 0 \text{ Vdc}, T_A = T_L \text{ to } T_H)$$

Num	Parameter	Symbol	Min	Max	Unit
1	Input pin frequency <sup>1</sup>	$f_{PCNTR}$	0	$f_{sys}/4$	MHz
2	Input pin low time	$t_{PINL}$	$2.0/f_{sys}$	—	$\mu\text{s}$
3	Input pin high time	$t_{PINH}$	$2.0/f_{sys}$	—	$\mu\text{s}$
4	Clock pin to counter increment	$t_{PINC}$	$4.5/f_{sys}$	$6.5/f_{sys}$	$\mu\text{s}$
5	Clock pin to new TBB value	$t_{PTBB}$	$5.0/f_{sys}$	$7.0/f_{sys}$	$\mu\text{s}$
6	Clock pin to COF set (\$FFFF)	$t_{PCOF}$	$4.5/f_{sys}$	$6.5/f_{sys}$	$\mu\text{s}$
7	Load pin to new counter value	$t_{PLOAD}$	$2.5/f_{sys}$	$3.5/f_{sys}$	$\mu\text{s}$
8	Pin to IN bit delay	$t_{PINB}$	$1.5/f_{sys}$	$2.5/f_{sys}$	$\mu\text{s}$
9	Flag to IMB interrupt request	$t_{FIRQ}$	$1.0/f_{sys}$	$1.0/f_{sys}$	$\mu\text{s}$
10	Counter resolution <sup>2</sup>	$t_{CRES}$	—	$2.0/f_{sys}$	$\mu\text{s}$

## NOTES:

1. Value applies when using external clock.
2. Value applies when using internal clock. Minimum counter resolution depends on prescaler divide ratio selection.

**Table A-17 SASM Timing Characteristics** $(V_{DD} = 5.0 \text{ Vdc} \pm 5\%, V_{SS} = 0\text{Vdc}, T_A = T_L \text{ to } T_H)$ 

Num	Parameter	Symbol	Min	Max	Unit
1	Input pin low time	$t_{PINL}$	$2.0/f_{sys}$	—	$\mu\text{s}$
2	Input pin high time	$t_{PINH}$	$2.0/f_{sys}$	—	$\mu\text{s}$
3	Input capture resolution <sup>1</sup>	$t_{RESCA}$	—	$2.0/f_{sys}$	$\mu\text{s}$
4	Pin to input capture delay	$t_{PCAPT}$	$2.5/f_{sys}$	$4.5/f_{sys}$	$\mu\text{s}$
5	Pin to FLAG set	$t_{PFLAG}$	$2.5/f_{sys}$	$4.5/f_{sys}$	$\mu\text{s}$
6	Pin to IN bit delay	$t_{PINB}$	$1.5/f_{sys}$	$2.5/f_{sys}$	$\mu\text{s}$
7	OCT output pulse	$t_{OCT}$	$2.0/f_{sys}$	—	$\mu\text{s}$
8	Compare resolution	$t_{RESCM}$		$2.0/f_{sys}$	$\mu\text{s}$
9	TBB change to FLAG set	$t_{CFLAG}$	$1.5/f_{sys}$	$1.5/f_{sys}$	$\mu\text{s}$
10	TBB change to pin change <sup>2</sup>	$t_{CPIN}$	$1.5/f_{sys}$	$1.5/f_{sys}$	$\mu\text{s}$
11	FLAG to IMB interrupt request	$t_{FIRQ}$	$1.0/f_{sys}$	$1.0/f_{sys}$	$\mu\text{s}$

**NOTES:**

1. Minimum resolution depends on counter and prescaler divide ratio selection.
2. Time given from when new value is stable on time base bus.

**Table A-18 DASM Timing Characteristics** $(V_{DD} = 5.0 \text{ Vdc} \pm 5\%, V_{SS} = 0 \text{ Vdc}, T_A = T_L \text{ to } T_H)$ 

Num	Parameter	Symbol	Min	Max	Unit
1	Input pin low time	$t_{PINL}$	$2.0/f_{sys}$	—	$\mu\text{S}$
2	Input pin high time	$t_{PINH}$	$2.0/f_{sys}$	—	$\mu\text{S}$
3	Input capture resolution <sup>1</sup>	$t_{RESCA}$	—	$2.0/f_{sys}$	$\mu\text{S}$
4	Pin to input capture delay	$t_{PCAPT}$	$2.5/f_{sys}$	$4.5/f_{sys}$	$\mu\text{S}$
5	Pin to FLAG set	$t_{PFLAG}$	$2.5/f_{sys}$	$4.5/f_{sys}$	$\mu\text{S}$
6	Pin to IN bit delay	$t_{PINB}$	$1.5/f_{sys}$	$2.5/f_{sys}$	$\mu\text{S}$
7	OCT output pulse	$t_{OCT}$	$2.0/f_{sys}$	—	$\mu\text{S}$
8	Compare resolution	$t_{RESCM}$	—	$2.0/f_{sys}$	$\mu\text{S}$
9	TBB change to FLAG set	$t_{CFLAG}$	$1.5/f_{sys}$	$1.5/f_{sys}$	$\mu\text{S}$
10	TBB change to pin change <sup>2</sup>	$t_{CPIN}$	$1.5/f_{sys}$	$1.5/f_{sys}$	$\mu\text{S}$
11	FLAG to IMB interrupt request	$t_{FIRQ}$	$1.0/f_{sys}$	$1.0/f_{sys}$	$\mu\text{S}$

## NOTES:

1. Minimum resolution depends on counter and prescaler divide ratio selection.
2. Time given from when new value is stable on time base bus.

**Table A-19 PWMSM Timing Characteristics** $(V_{DD} = 5.0Vdc \pm 5\%, V_{SS} = 0 Vdc, T_A = T_L \text{ to } T_H)$ 

Num	Parameter	Symbol	Min	Max	Unit
1	PWMSM output resolution <sup>1</sup>	$t_{PWMR}$	—	—	$\mu\text{s}$
2	PWMSM output pulse <sup>2</sup>	$t_{PWMO}$	$2.0/f_{\text{sys}}$	—	$\mu\text{s}$
3	PWMSM output pulse <sup>3</sup>	$t_{PWMO}$	$2.0/f_{\text{sys}}$	$2.0/f_{\text{sys}}$	$\mu\text{s}$
4	CPSM enable to output set PWMSM enabled before CPSM , DIV23 = 0 PWMSM enabled before CPSM , DIV23 = 1	$t_{PWMP}$	$3.5/f_{\text{sys}}$ $6.5/f_{\text{sys}}$	—	$\mu\text{s}$
5	PWM enable to output set PWMSM enabled before CPSM , DIV23 = 0 PWMSM enabled before CPSM , DIV23 = 1	$t_{PWME}$	$3.5/f_{\text{sys}}$ $5.5/f_{\text{sys}}$	$4.5/f_{\text{sys}}$ $6.5/f_{\text{sys}}$	$\mu\text{s}$
6	FLAG to IMB interrupt request	$t_{FIRQ}$	$1.5/f_{\text{sys}}$	$2.5/f_{\text{sys}}$	$\mu\text{s}$

**NOTES:**

1. Minimum output resolution depends on counter and prescaler divide ratio selection.
2. Excluding the case where the output is always zero.
3. Excluding the case where the output is always zero.

# APPENDIX B MECHANICAL DATA AND ORDERING INFORMATION

The MC68336 and the MC68376 are both available in 160-pin plastic surface mount packages. This appendix provides package pin assignment drawings, a dimensional drawing and ordering information.

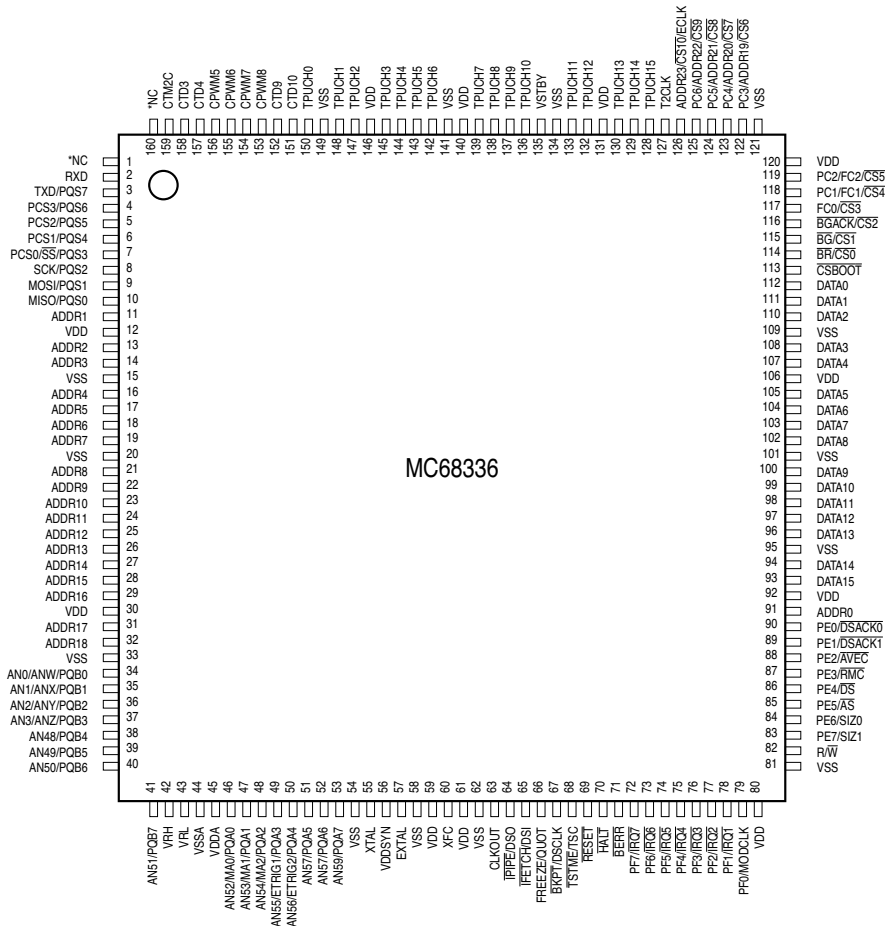

\*NOTE: MC68336 REVISION D AND LATER (F60K AND LATER MASK SETS) HAVE ASSIGNED PINS 1 AND 160 AS "NO CONNECT", TO ALLOW PIN COMPATIBILITY WITH THE MC68376. FOR REVISION C (D65J MASK SET) DEVICES, PIN 1 IS V<sub>SS</sub> AND PIN 160 IS V<sub>DD</sub>.

336 160-PIN OFP

**Figure B-1 MC68336 Pin Assignments for 160-Pin Package**

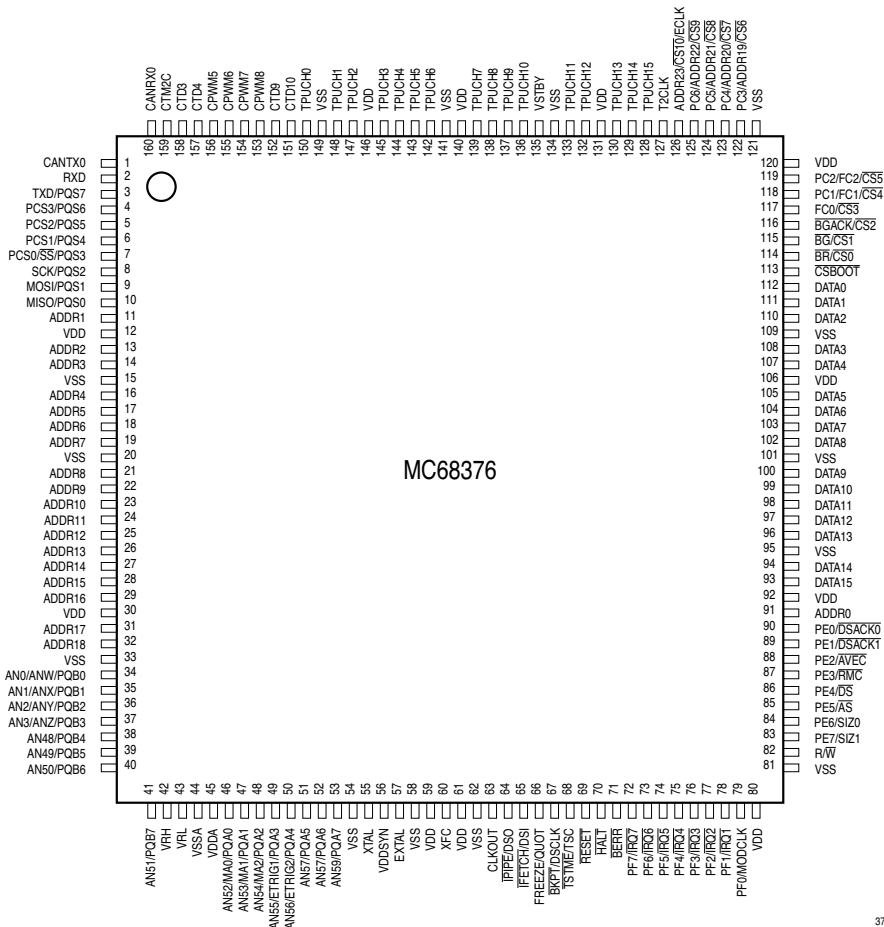

376 160-PIN QFP

Figure B-2 MC68376 Pin Assignments for 160-Pin Package



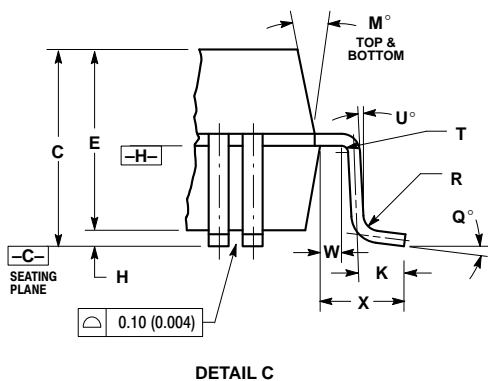
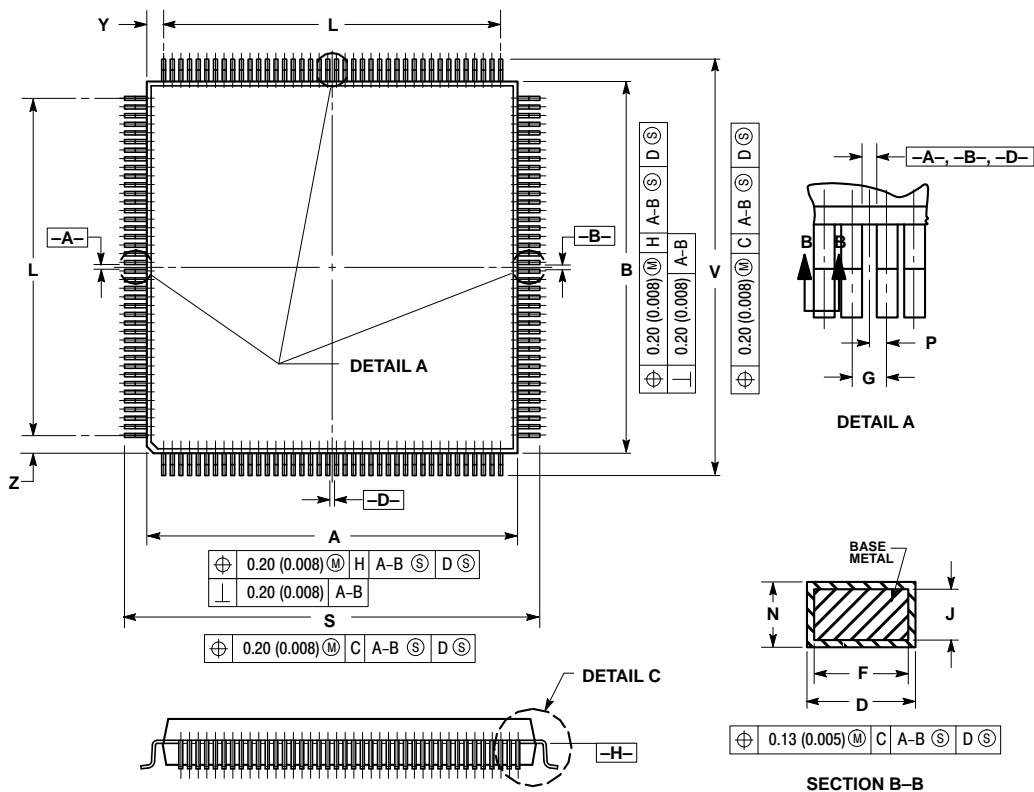

- NOTES:
1. DIMENSIONING AND TOLERANCING PER ANSI Y14.5M, 1982.
  2. CONTROLLING DIMENSION: MILLIMETER.
  3. DATUM PLANE -H- IS LOCATED AT BOTTOM OF LEAD AND IS COINCIDENT WITH THE LEAD WHERE THE LEAD EXITS THE PLASTIC BODY AT THE BOTTOM OF THE PARTING LINE.
  4. DATUMS -A-, -B-, AND -D- TO BE DETERMINED AT DATUM PLANE -H-.
  5. DIMENSIONS S AND V TO BE DETERMINED AT SEATING PLANE -C-.
  6. DIMENSIONS A AND B DO NOT INCLUDE MOLD PROTRUSION. ALLOWABLE PROTRUSION IS 0.25 (0.010) PER SIDE. DIMENSIONS A AND B DO INCLUDE MOLD MISMATCH AND ARE DETERMINED AT DATUM PLANE -H-.
  7. DIMENSION D DOES NOT INCLUDE DAMBAR PROTRUSION. ALLOWABLE DAMBAR PROTRUSION SHALL BE 0.08 (0.003) TOTAL IN EXCESS OF THE D DIMENSION AT MAXIMUM MATERIAL CONDITION. DAMBAR CANNOT BE LOCATED ON THE LOWER RADIUS OR THE FOOT.

DIM	MILLIMETERS		INCHES	
	MIN	MAX	MIN	MAX
A	27.90	28.10	1.098	1.106
B	27.90	28.10	1.098	1.106
C	3.35	3.85	0.132	0.152
D	0.22	0.38	0.009	0.015
E	3.20	3.50	0.126	0.138
F	0.22	0.33	0.009	0.013
G	0.65 BSC		0.026 REF	
H	0.25	0.35	0.010	0.014
J	0.11	0.23	0.004	0.009
K	0.70	0.90	0.028	0.035
L	25.35 REF		0.998 REF	
M	5°	16°	5°	16°
N	0.11	0.19	0.004	0.007
P	0.325 BSC		0.013 BSC	
Q	0°	7°	0°	7°
R	0.13	0.30	0.005	0.012
S	31.00	31.40	1.220	1.236
T	0.13	---	0.005	---
U	0°	---	0°	---
V	31.00	31.40	1.220	1.236
W	0.40	---	0.016	---
X	1.60 REF		0.063 REF	
Y	1.33 REF		0.052 REF	
Z	1.33 REF		0.052 REF	

### Case Outline 864A-03

Figure B-3 160-Pin Package Dimensions

## B.1 Obtaining Updated MC68336/376 Mechanical Information

Although all devices manufactured by Motorola conform to current JEDEC standards, complete mechanical information regarding MC68336/376 microcontrollers is available through Motorola's website at [motorola.com](http://motorola.com)

To download updated package specifications, go to website

## B.2 Ordering Information

Refer to **Table B-1** for MC68336 ordering information and **Table B-2** for MC68376 ordering information. Contact a Motorola sales representative for information on ordering a custom ROM device.

**Table B-1 MC68336 Ordering Information**

Part Number	Package Type	Frequency (MHz)	TPU	Temperature	Package Order Quantity	Order Number
MC68336	160-pin QFP	20.97 MHz	A	-40 to +85 °C	2	SPMC68336ACFT20
					24	MC68336ACFT20
					120	MC68336ACFT20B1
				-40 to +105 °C	2	SPMC68336AVFT20
					24	MC68336AVFT20
					120	MC68336AVFT20B1
				-40 to +125 °C	2	SPMC68336AMFT20
					24	MC68336AMFT20
					120	MC68336AMFT20B1
			G	-40 to +85 °C	2	SPMC68336GCFT20
					24	MC68336GCFT20
					120	MC68336GCFT20B1
				-40 to +105 °C	2	SPMC68336GVFT20
					24	MC68336GVFT20
					120	MC68336GVFT20B1
				-40 to +125 °C	2	SPMC68336GMFT20
					24	MC68336GMFT20
					120	MC68336GMFT20B1

**Table B-2 MC68376 Ordering Information**

Part Number	Package Type	Frequency (MHz)	TPU	Mask ROM	Temperature	Package Order Quantity	Order Number
MC68376	160-pin QFP	20.97 MHz	A	Blank	-40 to +85 °C	2	SPMC68376BACFT20
						24	MC68376BACFT20
						120	MC68376BACFT20B1
					-40 to +105 °C	2	SPMC68376BAVFT20
						24	MC68376BAVFT20
						120	MC68376BAVFT20B1
					-40 to +125 °C	2	SPMC68376BAMFT20
						24	MC68376BAMFT20
						120	MC68376BAMFT20B1
			G	Blank	-40 to +85 °C	2	SPMC68376BGCFT20
						24	MC68376BGCFT20
						120	MC68376BGCFT20B1
					-40 to +105 °C	2	SPMC68376BGVFT20
						24	MC68376BGVFT20
						120	MC68376BGVFT20B1
					-40 to +125 °C	2	SPMC68376BGMFT20
						24	MC68376BGMFT20
						120	MC68376BGMFT20B1



## APPENDIX C DEVELOPMENT SUPPORT

This section serves as a brief reference to Motorola development tools for MC68336 and MC68376 microcontrollers.

Information provided is complete as of the time of publication, but new systems and software are continually being developed. In addition, there is a growing number of third-party tools available. The Motorola *Microcontroller Development Tools Directory* (MCUDEVTLDIR/D Revision. 3) provides an up-to-date list of development tools. Contact your Motorola representative for further information.

### C.1 M68MMDS1632 Modular Development System

The M68MMDS1632 Motorola Modular Development System (MMDS) is a development tool for evaluating M68HC16 and M68300 MCU-based systems. The MMDS1632 is an emulator, bus state analyzer, and control station for debugging hardware and software. A separately purchased MPB completes MMDS functionality with regard to a particular MCU or MCU family. The many MPBs available let your MMDS emulate a variety of different MCUs. Contact your Motorola sales representative, who will assist you in selecting and configuring the modular system that fits your needs. A full-featured development system, the MMDS provides both in-circuit emulation and bus analysis capabilities, including:

- Real-time in-circuit emulation at maximum speed of 20 MHz
- Built-in emulation memory
  - 1-Mbyte main emulation memory (three-clock bus cycle)
  - 256-Kbyte fast termination (two-clock bus cycle)
  - 4-Kbyte dual-port emulation memory (three-clock bus cycle)
- Real-time bus analysis
  - Instruction disassembly
  - State-machine-controlled triggering
- Four hardware breakpoints, bitwise masking
- Analog/digital emulation
- Synchronized signal output
- Built-in AC power supply, 90–264 V, 50–60 Hz, FCC and EC EMI compliant
- RS-232 connection to host capable of communicating at 1200, 2400, 4800, 9600, 19200, 38400, or 57600 baud

### C.2 M68MEVB1632 Modular Evaluation Board

The M68MEVB1632 Modular Evaluation Board (MEVB) is a development tool for evaluating M68HC16 and M68300 MCU-based systems. The MEVB consists of the M68MPFB1632 modular platform board, an MCU personality board (MPB), an in-circuit debugger (ICD16 or ICD32), and development software. MEVB features include:

- An economical means of evaluating target systems incorporating M68HC16 and M68300 HCMOS MCU devices.
- Expansion memory sockets for installing RAM, EPROM, or EEPROM.
  - Data RAM: 32K x 16, 128K x 16, or 512K x 16
  - EPROM/EEPROM: 32K x 16, 64K x 16, 128K x 16, 256K x 16, or 512K x 16
  - Fast RAM: 32K x 16 or 128K x 16
- Background-mode operation, for detailed operation from a personal computer platform without an on-board monitor.
- Integrated assembly/editing/evaluation/programming environment for easy development.
- As many as seven software breakpoints.
- Re-usable ICD hardware for your target application debug or control.
- Two RS-232C terminal input/output (I/O) ports for user evaluation of the serial communication interface.
- Logic analyzer pod connectors.
- Port replacement unit (PRU) to rebuild I/O ports lost to address/data/control.
- On-board  $V_{PP}$  (+12 VDC) generation for MCU and flash EEPROM programming.
- On-board wire-wrap area.

## APPENDIX D REGISTER SUMMARY

This appendix contains address maps, register diagrams, and bit/field definitions for MC68336 and MC68376 microcontrollers. More detailed information about register function is provided in the appropriate sections of the manual.

Except for central processing unit resources, information is presented in the intermodule bus address order shown in **Table D-1**.

**Table D-1 Module Address Map**

Module	Size (Bytes)	Base Address
SIM	128	\$YFFA00
SRAM	8	\$YFFB40
MRM (MC68376 Only)	32	\$YFF820
QADC	512	\$YFF200
QSM	512	\$YFFC00
CTM4	256	\$YFF400
TPU	512	\$YFFE00
TPURAM	64	\$YFFB00
TouCAN (MC68376 Only)	384	\$YFF080

Control registers for all the modules in the microcontroller are mapped into a 4-Kbyte block. The state of the module mapping (MM) bit in the SIM configuration register (SIMCR) determines where the control register block is located in the system memory map. When MM = 0, register addresses range from \$7FF000 to \$7FFFFFF; when MM = 1, register addresses range from \$FFF000 to \$FFFFFF.

In the module memory maps in this appendix, the "Access" column specifies which registers are accessible when the CPU32 is in supervisor mode only and which registers can be assigned to either supervisor or user mode.

### D.1 Central Processor Unit

CPU32 registers are not part of the module address map. **Figures D-1** and **D-2** show a functional representation of CPU32 resources.

### D.1.1 CPU32 Register Model

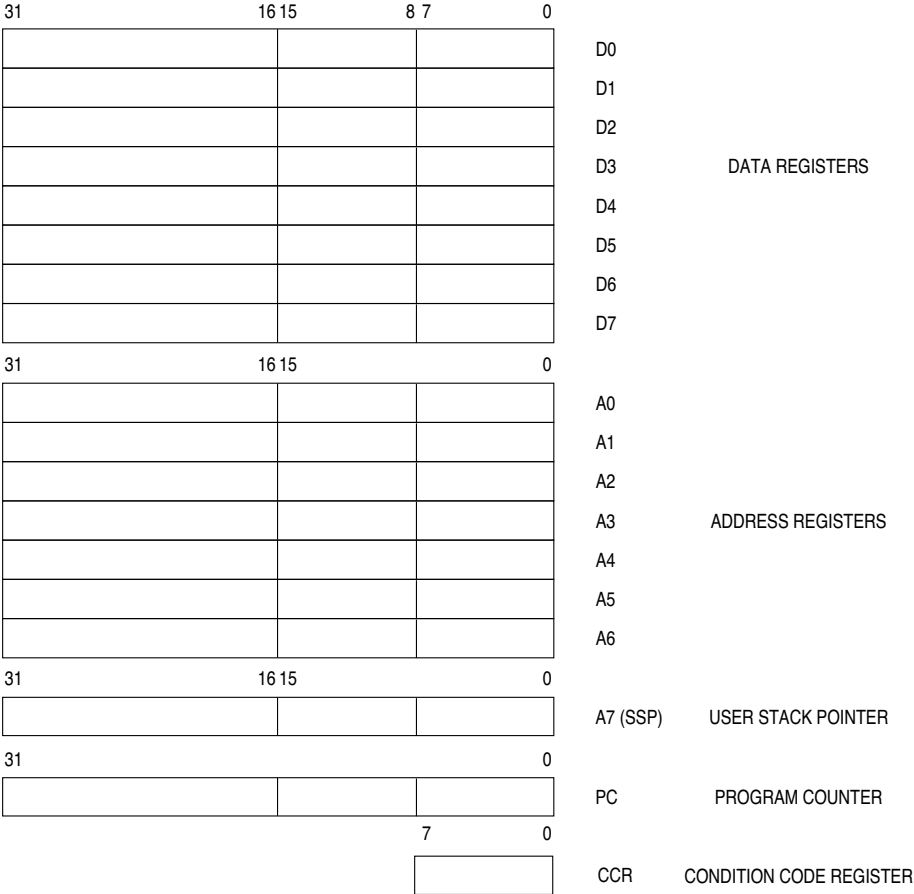

CPU32 USER PROG MODEL

**Figure D-1 User Programming Model**



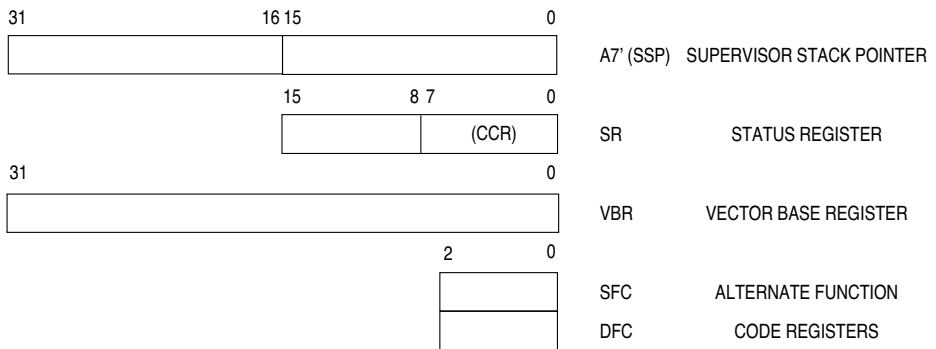

CPU32 SUPV PROG MODEL

**Figure D-2 Supervisor Programming Model Supplement**

## D.1.2 Status Register

### SR — Status Register

15	14	13	12	11	10	9	8	7	6	5	4	3	2	1	0
T[1:0]	S	0	0	IP[2:0]			0	0	0	X	N	Z	V	C	
RESET:															
0	0	1	0	0	1	1	1	0	0	0	U	U	U	U	U

The status register (SR) contains condition codes, an interrupt priority mask, and three control bits. The condition codes are contained in the condition code register (CCR), the lower byte of the SR. (The lower and upper bytes of the status register are also referred to as the user and system bytes, respectively.) In user mode, only the CCR is available. In supervisor mode, software can access the full status register.

#### T[1:0] — Trace Enable

This field places the processor in one of two tracing modes or disables tracing. Refer to **Table D-2**.

**Table D-2 T[1:0] Encoding**

T[1:0]	Response
00	No tracing
01	Trace on change of flow
10	Trace on instruction execution
11	Undefined; reserved

S — Supervisor/User State

0 = CPU operates at user privilege level

1 = CPU operates at supervisor privilege level

IP[2:0] — Interrupt Priority Mask

The priority value in this field (0 to 7) is used to mask interrupts.

X — Extend Flag

Used in multiple-precision arithmetic operations. In many instructions, it is set to the same value as the C bit.

N — Negative Flag

Set when the MSB of a result register is set.

Z — Zero Flag

Set when all bits of a result register are zero.

V — Overflow Flag

Set when two's complement overflow occurs as the result of an operation.

C — Carry Flag

Set when a carry or borrow occurs during an arithmetic operation. Also used during shift and rotate instructions to facilitate multiple word operations.

## D.2 System Integration Module

**Table D-3** shows the SIM address map. The column labeled “Access” indicates the privilege level at which the CPU32 must be operating to access the register. A designation of “S” indicates that supervisor mode is required. A designation of “S/U” indicates that the register can be programmed for either supervisor mode access or unrestricted access.

**Table D-3 SIM Address Map**

Access	Address <sup>1</sup>	15	8	7	0
S	\$YFFA00	SIM Module Configuration Register (SIMCR)			
S	\$YFFA02	SIM Test Register (SIMTR)			
S	\$YFFA04	Clock Synthesizer Control Register (SYNCR)			
S	\$YFFA06	Not Used		Reset Status Register (RSR)	
S	\$YFFA08	SIM Test Register E (SIMTRE)			
S	\$YFFA0A	Not Used			
S	\$YFFA0C	Not Used			
S	\$YFFA0E	Not Used			
S/U	\$YFFA10	Not Used		Port E Data (PORTE0)	
S/U	\$YFFA12	Not Used		Port E Data (PORTE1)	
S/U	\$YFFA14	Not Used		Port E Data Direction (DDRE)	
S	\$YFFA16	Not Used		Port E Pin Assignment (PEPAR)	
S/U	\$YFFA18	Not Used		Port F Data (PORTF0)	
S/U	\$YFFA1A	Not Used		Port F Data (PORTF1)	
S/U	\$YFFA1C	Not Used		Port F Data Direction (DDRF)	
S	\$YFFA1E	Not Used		Port F Pin Assignment (PFPAR)	
S	\$YFFA20	Not Used		System Protection Control (SYPCR)	
S	\$YFFA22	Periodic Interrupt Control Register (PICR)			
S	\$YFFA24	Periodic Interrupt Timing Register (PITR)			
S	\$YFFA26	Not Used		Software Service (SWSR)	
S	\$YFFA28	Not Used			
S	\$YFFA2A	Not Used			
S	\$YFFA2C	Not Used			
S	\$YFFA2E	Not Used			
S	\$YFFA30	Test Module Master Shift A (TSTMSRA)			
S	\$YFFA32	Test Module Master Shift B (TSTMSRB)			
S	\$YFFA34	Test Module Shift Count (TSTSC)			
S	\$YFFA36	Test Module Repetition Counter (TSTRC)			
S	\$YFFA38	Test Module Control (CREG)			
S/U	\$YFFA3A	Test Module Distributed (DREG)			
	\$YFFA3C	Not Used			
	\$YFFA3E	Not Used			
S/U	\$YFFA40	Not Used		Port C Data (PORTC)	
	\$YFFA42	Not Used			
S	\$YFFA44	Chip-Select Pin Assignment (CSPAR0)			
S	\$YFFA46	Chip-Select Pin Assignment (CSPAR1)			
S	\$YFFA48	Chip-Select Base Boot (CSBARBT)			
S	\$YFFA4A	Chip-Select Option Boot (CSORBT)			
S	\$YFFA4C	Chip-Select Base 0 (CSBAR0)			
S	\$YFFA4E	Chip-Select Option 0 (CSOR0)			

**Table D-3 SIM Address Map (Continued)**

Access	Address <sup>1</sup>	15	8	7	0
S	\$YFFA50	Chip-Select Base 1 (CSBAR1)			
S	\$YFFA52	Chip-Select Option 1 (CSOR1)			
S	\$YFFA54	Chip-Select Base 2 (CSBAR2)			
S	\$YFFA56	Chip-Select Option 2 (CSOR2)			
S	\$YFFA58	Chip-Select Base 3 (CSBAR3)			
S	\$YFFA5A	Chip-Select Option 3 (CSOR3)			
S	\$YFFA5C	Chip-Select Base 4 (CSBAR4)			
S	\$YFFA5E	Chip-Select Option 4 (CSOR4)			
S	\$YFFA60	Chip-Select Base 5 (CSBAR5)			
S	\$YFFA62	Chip-Select Option 5 (CSOR5)			
S	\$YFFA64	Chip-Select Base 6 (CSBAR6)			
S	\$YFFA66	Chip-Select Option 6 (CSOR6)			
S	\$YFFA68	Chip-Select Base 7 (CSBAR7)			
S	\$YFFA6A	Chip-Select Option 7 (CSOR7)			
S	\$YFFA6C	Chip-Select Base 8 (CSBAR8)			
S	\$YFFA6E	Chip-Select Option 8 (CSOR8)			
S	\$YFFA70	Chip-Select Base 9 (CSBAR9)			
S	\$YFFA72	Chip-Select Option 9 (CSOR9)			
S	\$YFFA74	Chip-Select Base 10 (CSBAR10)			
S	\$YFFA76	Chip-Select Option 10 (CSOR10)			
	\$YFFA78	Not Used			
	\$YFFA7A	Not Used			
	\$YFFA7C	Not Used			
	\$YFFA7E	Not Used			

NOTES:

1. Y = M111, where M is the logic state of the module mapping (MM) bit in the SIMCR.

## D.2.1 SIM Configuration Register

### SIMCR — SIM Configuration Register

**\$TFFA00**

15	14	13	12	11	10	9	8	7	6	5	4	3	2	1	0
EXOFF	FRZSW	FRZBM	0	RSVD <sup>1</sup>	0	SHEN[1:0]	SUPV	MM	0	0	IARB[3:0]				
RESET:															
0	0	0	0	DATA11	0	0	0	1	1	0	0	1	1	1	1

NOTES:

1. This bit must be left at zero. Pulling DATA11 high during reset ensures this bit remains zero. A one in this bit could allow the MCU to enter an unsupported operating mode.

SIMCR controls system configuration. SIMCR can be read or written at any time, except for the module mapping (MM) bit, which can only be written once.

### EXOFF — External Clock Off

0 = The CLKOUT pin is driven during normal operation.

1 = The CLKOUT pin is placed in a high-impedance state.

FRZSW — Freeze Software Enable

0 = When FREEZE is asserted, the software watchdog and periodic interrupt timer counters continue to run.

1 = When FREEZE is asserted, the software watchdog and periodic interrupt timer counters are disabled, preventing interrupts during background debug mode.

FRZBM — Freeze Bus Monitor Enable

0 = When FREEZE is asserted, the bus monitor continues to operate.

1 = When FREEZE is asserted, the bus monitor is disabled.

SHEN[1:0] — Show Cycle Enable

The SHEN field determines how the external bus is driven during internal transfer operations. A show cycle allows internal transfers to be monitored externally.

**Table D-4** shows whether show cycle data is driven externally, and whether external bus arbitration can occur. To prevent bus conflict, external peripherals must not be enabled during show cycles.

**Table D-4 Show Cycle Enable Bits**

SHEN[1:0]	Action
00	Show cycles disabled, external arbitration enabled
01	Show cycles enabled, external arbitration disabled
10	Show cycles enabled, external arbitration enabled
11	Show cycles enabled, external arbitration enabled; internal activity is halted by a bus grant

SUPV — Supervisor/Unrestricted Data Space

The SUPV bit places the SIM global registers in either supervisor or user data space.

0 = Registers with access controlled by the SUPV bit are accessible in either supervisor or user mode.

1 = Registers with access controlled by the SUPV bit are restricted to supervisor access only.

MM — Module Mapping

0 = Internal modules are addressed from \$7FF000 – \$7FFFFFF.

1 = Internal modules are addressed from \$FFF000 – \$FFFFFF.

IARB[3:0] — Interrupt Arbitration ID

Each module that can generate interrupts, including the SIM, has an IARB field. Each IARB field can be assigned a value from \$0 to \$F. During an interrupt acknowledge cycle, IARB permits arbitration among simultaneous interrupts of the same priority level. The reset value of the SIM IARB field is \$F. This prevents SIM interrupts from being discarded during system initialization.

## D.2.2 System Integration Test Register

**SIMTR** — System Integration Test Register

**\$YFFA02**

Used for factory test only.

## D.2.3 Clock Synthesizer Control Register

### SYNCR — Clock Synthesizer Control Register

**\$YFFA04**

15	14	13	12	11	10	9	8	7	6	5	4	3	2	1	0	
W	X	Y[5:0]					EDIV	0	0	RSVD <sup>1</sup>	SLOCK	RSVD <sup>1</sup>	STSIM	STEXT		

RESET:

0 0 1 1 1 1 1 1 0 0 0 0 U 0 0 0

NOTES:

1. Ensure that initialization software does not change the value of these bits. They should always be zero.

SYNCR determines system clock operating frequency and operation during low-power stop mode. Clock frequency is determined by SYNCR bit settings as follows:

$$f_{\text{sys}} = \frac{f_{\text{ref}}}{128} [4(Y + 1)(2^{(2W + X)})]$$

#### W — Frequency Control (VCO)

This bit controls a prescaler tap in the synthesizer feedback loop. Setting this bit increases the VCO speed by a factor of four. VCO relock delay is required.

#### X — Frequency Control (Prescaler)

This bit controls a divide by two prescaler that is not in the synthesizer feedback loop. Setting the bit doubles clock speed without changing the VCO speed. No VCO relock delay is required.

#### Y[5:0] — Frequency Control (Counter)

The Y field controls the modulus down counter in the synthesizer feedback loop, causing it to divide by a value of Y + 1. VCO relock delay is required.

#### EDIV — E Clock Divide Rate

0 = ECLK frequency is system clock divided by 8.

1 = ECLK frequency is system clock divided by 16.

ECLK is an external M6800 bus clock available on ADDR23.

#### SLOCK — Synthesizer Lock Flag

0 = VCO is enabled, but has not locked.

1 = VCO has locked on the desired frequency or VCO is disabled.

The MCU remains in reset until the synthesizer locks, but SLOCK does not indicate synthesizer lock status until after the user writes to SYNCR.

#### STSIM — Stop Mode SIM Clock

0 = When LPSTOP is executed, the SIM clock is driven from the crystal oscillator and the VCO is turned off to conserve power.

1 = When LPSTOP is executed, the SIM clock is driven from the VCO.

STEXT — Stop Mode External Clock

0 = When LPSTOP is executed, the CLKOUT signal is held negated to conserve power.

1 = When LPSTOP is executed and EXOFF  $\neq$  1 in SIMCR, the CLKOUT signal is driven from the SIM clock, as determined by the state of the STSIM bit.

## D.2.4 Reset Status Register

RSR — Reset Status Register

**\$YFFA07**

15		8	7	6	5	4	3	2	1	0
NOT USED			EXT	POW	SW	HLT	0	RSVD	SYS	TST

RSR contains a status bit for each reset source in the MCU. RSR is updated when the MCU comes out of reset. A set bit indicates what type of reset occurred. If multiple sources assert reset signals at the same time, more than one bit in RSR may be set. This register can be read at any time; writes have no effect.

EXT — External Reset

Reset caused by the  $\overline{\text{RESET}}$  pin.

POW — Power-Up Reset

Reset caused by the power-up reset circuit.

SW — Software Watchdog Reset

Reset caused by the software watchdog circuit.

HLT — Halt Monitor Reset

Reset caused by the halt monitor.

SYS — System Reset

Reset caused by a RESET instruction.

TST — Test Submodule Reset

Reset caused by the test submodule. Used during system test only.

## D.2.5 System Integration Test Register (ECLK)

SIMTRE — System Integration Test Register (ECLK)

**\$YFFA08**

Used for factory test only.

## D.2.6 Port E Data Register

**PORTE0** — Port E0 Data Register

**\$YFFFA11**

**PORTE1** — Port E1 Data Register

**\$YFFFA13**

15	8	7	6	5	4	3	2	1	0
NOT USED		PE7	PE6	PE5	PE4	PE3	PE2	PE1	PE0
RESET:									
		U	U	U	U	U	U	U	U

PORTE is an internal data latch that can be accessed at two locations. It can be read or written at any time. If a port E I/O pin is configured as an output, the corresponding bit value is driven out on the pin. When a pin is configured as an output, a read of PORTE returns the latched bit value; when a pin is configured as an input, a read returns the pin logic level.

## D.2.7 Port E Data Direction Register

**DDRE** — Port E Data Direction Register

**\$YFFFA15**

15	8	7	6	5	4	3	2	1	0
NOT USED		DDE7	DDE6	DDE5	DDE4	DDE3	DDE2	DDE1	DDE0
RESET:									
		0	0	0	0	0	0	0	0

Bits in this register control the direction of the port E pin drivers when pins are configured for I/O. Setting a bit configures the corresponding pin as an output; clearing a bit configures the corresponding pin as an input. This register can be read or written at any time.

## D.2.8 Port E Pin Assignment Register

**PEPAR** — Port E Pin Assignment

**\$YFFFA17**

15	8	7	6	5	4	3	2	1	0
NOT USED		PEPA7	PEPA6	PEPA5	PEPA4	PEPA3	PEPA2	PEPA1	PEPA0
RESET:									
		DATA8	DATA8	DATA8	DATA8	DATA8	DATA8	DATA8	DATA8

Bits in this register determine the function of port E pins. Setting a bit assigns the corresponding pin to a bus control signal; clearing a bit assigns the pin to I/O port E. Refer to **Table D-5**.



**Table D-5 Port E Pin Assignments**

PEPAR Bit	Port E Signal	Bus Control Signal
PEPA7	PE7	SIZ1
PEPA6	PE6	SIZ0
PEPA5	PE5	AS
PEPA4	PE4	DS
PEPA3	PE3	RMC
PEPA2	PE2	AVEC
PEPA1	PE1	DSACK1
PEPA0	PE0	DSACK0

### D.2.9 Port F Data Register

**PORTF0**— Port F Data Register 0

**\$YFFA19**

**PORTF1**— Port F Data Register 1

**\$YFFA1B**

15	8	7	6	5	4	3	2	1	0
NOT USED		PF7	PF6	PF5	PF4	PF3	PF2	PF1	PF0

RESET:

U U U U U U U U

PORTF is an internal data latch that can be accessed at two locations. It can be read or written at any time. If a port F I/O pin is configured as an output, the corresponding bit value is driven out on the pin. When a pin is configured as an output, a read of PORTF returns the latched bit value; when a pin is configured as an input, a read returns the pin logic level.

### D.2.10 Port F Data Direction Register

**DDRF** — Port F Data Direction Register

**\$YFFA1D**

15	8	7	6	5	4	3	2	1	0
NOT USED		DDF7	DDF6	DDF5	DDF4	DDF3	DDF2	DDF1	DDF0

RESET:

0 0 0 0 0 0 0 0 0

Bits in this register control the direction of the port F pin drivers when pins are configured for I/O. Setting a bit configures the corresponding pin as an output; clearing a bit configures the corresponding pin as an input. This register can be read or written at any time.

### D.2.11 Port F Pin Assignment Register

**PFFPAR** — Port F Pin Assignment Register

**\$YFFA1F**

15	8	7	6	5	4	3	2	1	0
NOT USED		PFFPA7	PFFPA6	PFFPA5	PFFPA4	PFFPA3	PFFPA2	PFFPA1	PFFPA0

RESET:

DATA9 DATA9 DATA9 DATA9 DATA9 DATA9 DATA9 DATA9

Bits in this register determine the function of port F pins. Setting a bit assigns the corresponding pin to a control signal; clearing a bit assigns the pin to port F. Refer to **Table D-6**.

**Table D-6 Port F Pin Assignments**

PFPA Field	Port F Signal	Alternate Signal
PFPA7	PF7	$\overline{\text{IRQ7}}$
PFPA6	PF6	$\overline{\text{IRQ6}}$
PFPA5	PF5	$\overline{\text{IRQ5}}$
PFPA4	PF4	$\overline{\text{IRQ4}}$
PFPA3	PF3	$\overline{\text{IRQ3}}$
PFPA2	PF2	$\overline{\text{IRQ2}}$
PFPA1	PF1	$\overline{\text{IRQ1}}$
PFPA0	PF0	MODCLK

### D.2.12 System Protection Control Register

**SYPCR** — System Protection Control Register

**\$YFFA21**

15	8	7	6	5	4	3	2	1	0
NOT USED		SWE	SWP	SWT[1:0]	HME	BME	BMT[1:0]		
RESET:									
		1	$\overline{\text{MODCLK}}$	0	0	0	0	0	0

SYPCR controls system monitor functions, software watchdog clock prescaling, and bus monitor timing. This register can be written once following power-on or reset.

**SWE** — Software Watchdog Enable

0 = Software watchdog is disabled.

1 = Software watchdog is enabled.

**SWP** — Software Watchdog Prescale

This bit controls the value of the software watchdog prescaler.

0 = Software watchdog clock is not prescaled.

1 = Software watchdog clock is prescaled by 512.

The reset value of SWP is the complement of the state of the MODCLK pin during reset.

**SWT[1:0]** — Software Watchdog Timing

This field selects the divide ration used to establish software watchdog timeout period. Refer to **Table D-7**.

**Table D-7 Software Watchdog Timing Field**

SWP	SWT[1:0]	Watchdog Time-Out Period
0	00	$2^9 \div f_{\text{sys}}$
0	01	$2^{11} \div f_{\text{sys}}$
0	10	$2^{13} \div f_{\text{sys}}$
0	11	$2^{15} \div f_{\text{sys}}$
1	00	$2^{18} \div f_{\text{sys}}$
1	01	$2^{20} \div f_{\text{sys}}$
1	10	$2^{22} \div f_{\text{sys}}$
1	11	$2^{24} \div f_{\text{sys}}$

HME — Halt Monitor Enable

0 = Halt monitor is disabled.

1 = Halt monitor is enabled.

BME — Bus Monitor External Enable

0 = Disable bus monitor for internal to external bus cycle.

1 = Enable bus monitor for internal to external bus cycle.

BMT[1:0] — Bus Monitor Timing

This field selects the bus monitor time-out period. Refer to **Table D-8**.

**Table D-8 Bus Monitor Time-Out Period**

BMT[1:0]	Bus Monitor Time-Out Period
00	64 system clocks
01	32 system clocks
10	16 system clocks
11	8 system clocks

### D.2.13 Periodic Interrupt Control Register

**PICR** — Periodic Interrupt Control Register

**\$YFFA22**

15	14	13	12	11	10	9	8	7	6	5	4	3	2	1	0
0	0	0	0	0	PIRQL[2:0]			PIV[7:0]							

RESET:

0 0 0 0 0 0 0 0 0 0 0 0 1 1 1 1

PICR sets the interrupt level and vector number for the periodic interrupt timer (PIT).

Bits [10:0] can be read or written at any time. Bits [15:11] are unimplemented and always read zero.

PIRQL[2:0] — Periodic Interrupt Request Level

This field determines the priority of periodic interrupt requests. A value of %000 disables PIT interrupts.

PIV[7:0] — Periodic Interrupt Vector

This field specifies the periodic interrupt vector number supplied by the SIM when the CPU32 acknowledges an interrupt request.

## D.2.14 Periodic Interrupt Timer Register

**PITR** — Periodic Interrupt Timer Register

**\$YFFA24**

15	14	13	12	11	10	9	8	7	6	5	4	3	2	1	0
0	0	0	0	0	0	0	PTP	PITM[7:0]							

RESET:

0	0	0	0	0	0	0	MODCLK	0	0	0	0	0	0	0	0
---	---	---	---	---	---	---	--------	---	---	---	---	---	---	---	---

PITR specifies the prescaling and modulus value for the PIT. This register can be read or written at any time.

**PTP** — Periodic Timer Prescaler Control

0 = Periodic timer clock is not prescaled.

1 = Periodic timer clock is prescaled by 512.

**PITM[7:0]** — Periodic Interrupt Timing Modulus

This field determines the periodic interrupt rate. Use the following expressions to calculate timer period.

When a fast reference frequency is used, the PIT period can be calculated as follows:

$$\text{PIT Period} = \frac{(128)(\text{PITM}[7:0])(1 \text{ if } \text{PTP} = 0, 512 \text{ if } \text{PTP} = 1)(4)}{f_{\text{ref}}}$$

When an externally input clock frequency is used, the PIT period can be calculated as follows:

$$\text{PIT Period} = \frac{(\text{PITM}[7:0])(1 \text{ if } \text{PTP} = 0, 512 \text{ if } \text{PTP} = 1)(4)}{f_{\text{ref}}}$$

## D.2.15 Software Watchdog Service Register

**SWSR** — Software Watchdog Service Register<sup>1</sup>

**\$YFFA27**

15	8	7	6	5	4	3	2	1	0					
NOT USED								0	0	0	0	0	0	0

RESET:

0	0	0	0	0	0	0	0	0
---	---	---	---	---	---	---	---	---

NOTES:

1. Register shown with read value.

To reset the software watchdog:

1. Write \$55 to SWSR.
2. Write \$AA to SWSR.

Both writes must occur in the order specified before the software watchdog times out, but any number of instructions can occur between the two writes.

## D.2.16 Port C Data Register

### PORTC — Port C Data Register

\$YFFA41

15	8	7	6	5	4	3	2	1	0	
NOT USED			0	PC6	PC5	PC4	PC3	PC2	PC1	PC0
RESET:										
			0	1	1	1	1	1	1	1

PORTC latches data for chip-select pins configured as discrete outputs.

## D.2.17 Chip-Select Pin Assignment Registers

### CSPAR0 — Chip-Select Pin Assignment Register 0

\$YFFA44

15	14	13	12	11	10	9	8	7	6	5	4	3	2	1	0
0	0	CS5PA[1:0]	CS4PA[1:0]	CS3PA[1:0]	CS2PA[1:0]	CS1PA[1:0]	CS0PA[1:0]	CSBTPA[1:0]							
RESET:															
0	0	DATA2	1	DATA2	1	DATA2	1	DATA1	1	DATA1	1	DATA1	1	1	DATA0

The chip-select pin assignment registers configure the chip-select pins for use as discrete I/O, an alternate function, or as an 8-bit or 16-bit chip-select. Each 2-bit field in CSPAR[0:1] (except for CSBTPA[1:0]) has the possible encoding shown in **Table D-9**.

**Table D-9 Pin Assignment Field Encoding**

CSxPA[1:0]	Description
00	Discrete output <sup>1</sup>
01	Alternate function <sup>1</sup>
10	Chip-select (8-bit port)
11	Chip-select (16-bit port)

NOTES:

1. Does not apply to the  $\overline{\text{CSBOOT}}$  field.

CSPAR0 contains seven 2-bit fields that determine the function of corresponding chip-select pins. Bits [15:14] are not used. These bits always read zero; writes have no effect. CSPAR0 bit 1 always reads one; writes to CSPAR0 bit 1 have no effect. The alternate functions can be enabled by data bus mode selection during reset.

**Table D-10** shows CSPAR0 pin assignments.

**Table D-10 CSPAR0 Pin Assignments**

CSPAR0 Field	Chip-Select Signal	Alternate Signal	Discrete Output
CS5PA[1:0]	$\overline{CS5}$	FC2	PC2
CS4PA[1:0]	$\overline{CS4}$	FC1	PC1
CS3PA[1:0]	$\overline{CS3}$	FC0	PC0
CS2PA[1:0]	$\overline{CS2}$	BGACK	—
CS1PA[1:0]	$\overline{CS1}$	BG	—
CS0PA[1:0]	$\overline{CS0}$	BR	—
CSBTPA[1:0]	CSBOOT	—	—

**CSPAR1 — Chip-Select Pin Assignment Register 1**

**\$YFFA46**

15	14	13	12	11	10	9	8	7	6	5	4	3	2	1	0
0	0	0	0	0	0	CS10PA[1:0]	CS9PA[1:0]	CS8PA[1:0]	CS7PA[1:0]	CS6PA[1:0]					
RESET:															
0	0	0	0	0	0	DATA <sub>7</sub> 1	1	DATA [7:6] <sup>1</sup>	1	DATA [7:5] <sup>1</sup>	1	DATA [7:4] <sup>1</sup>	1	DATA [7:3] <sup>1</sup>	1

NOTES:

1. Refer to **Table D-12** for CSPAR1 reset state information.

CSPAR1 contains five 2-bit fields that determine the functions of corresponding chip-select pins. Bits [15:10] are not used. These bits always read zero; writes have no effect. **Table D-11** shows CSPAR1 pin assignments, including alternate functions that can be enabled by data bus mode selection during reset.

**Table D-11 CSPAR1 Pin Assignments**

CSPAR1 Field	Chip-Select Signal	Alternate Signal	Discrete Output
CS10PA[1:0]	$\overline{CS10}$	ADDR23	ECLK
CS9PA[1:0]	$\overline{CS9}$	ADDR22	PC6
CS8PA[1:0]	$\overline{CS8}$	ADDR21	PC5
CS7PA[1:0]	$\overline{CS7}$	ADDR20	PC4
CS6PA[1:0]	$\overline{CS6}$	ADDR19	PC3

The reset state of DATA[7:3] determines whether pins controlled by CSPAR1 are initially configured as high-order address lines or chip-selects. **Table D-12** shows the correspondence between DATA[7:3] and the reset configuration of  $\overline{CS}[10:6]$ /ADDR[23:19].

**Table D-12 Reset Pin Function of CS[10:6]**

Data Bus Pins at Reset					Chip-Select/Address Bus Pin Function				
DATA7	DATA6	DATA5	DATA4	DATA3	CS10/ ADDR23	CS9/ ADDR22	CS8/ ADDR21	CS7/ ADDR20	CS6/ ADDR19
1	1	1	1	1	CS10	CS9	CS8	CS7	CS6
1	1	1	1	0	CS10	CS9	CS8	CS7	ADDR19
1	1	1	0	X	CS10	CS9	CS8	ADDR20	ADDR19
1	1	0	X	X	CS10	CS9	ADDR21	ADDR20	ADDR19
1	0	X	X	X	CS10	ADDR22	ADDR21	ADDR20	ADDR19
0	X	X	X	X	ADDR23	ADDR22	ADDR21	ADDR20	ADDR19

### D.2.18 Chip-Select Base Address Register Boot ROM

**CSBARBT** — Chip-Select Base Address Register Boot ROM

**\$YFFA48**

15	14	13	12	11	10	9	8	7	6	5	4	3	2	1	0	
ADDR 23	ADDR 22	ADDR 21	ADDR 20	ADDR 19	ADDR 18	ADDR 17	ADDR 16	ADDR 15	ADDR 14	ADDR 13	ADDR 12	ADDR 11	BLKSZ[2:0]			
RESET:																
0	0	0	0	0	0	0	0	0	0	0	0	0	0	1	1	1

### D.2.19 Chip-Select Base Address Registers

**CSBAR[0:10]** — Chip-Select Base Address Registers

**\$YFFA4C–\$YFFA74**

15	14	13	12	11	10	9	8	7	6	5	4	3	2	1	0
ADDR 23	ADDR 22	ADDR 21	ADDR 20	ADDR 19	ADDR 18	ADDR 17	ADDR 16	ADDR 15	ADDR 14	ADDR 13	ADDR 12	ADDR 11	BLKSZ[2:0]		
RESET:															
0	0	0	0	0	0	0	0	0	0	0	0	0	0	0	0

Each chip-select pin has an associated base address register. A base address is the lowest address in the block of addresses enabled by a chip select. CSBARBT contains the base address for selection of a bootstrap memory device. Bit and field definitions for CSBARBT and CSBAR[0:10] are the same, but reset block sizes differ.

#### ADDR[23:11] — Base Address

This field sets the starting address of a particular chip-select's address space. The address compare logic uses only the most significant bits to match an address within a block. The value of the base address must be an integer multiple of the block size. Base address register diagrams show how base register bits correspond to address lines.

#### BLKSZ[2:0] — Block Size Field

This field determines the size of the block that is enabled by the chip-select.

**Table D-13** shows bit encoding for the base address registers block size field.

**Table D-13 Block Size Field Bit Encoding**

BLKSZ[2:0]	Block Size	Address Lines Compared
000	2 Kbytes	ADDR[23:11]
001	8 Kbytes	ADDR[23:13]
010	16 Kbytes	ADDR[23:14]
011	64 Kbytes	ADDR[23:16]
100	128 Kbytes	ADDR[23:17]
101	256 Kbytes	ADDR[23:18]
110	512 Kbytes	ADDR[23:19]
111	1 Mbyte	ADDR[23:20]

## D.2.20 Chip-Select Option Register Boot ROM

**CSORBT** — Chip-Select Option Register Boot ROM

**\$YFFA4A**

15	14	13	12	11	10	9	8	7	6	5	4	3	2	1	0
MODE	BYTE[1:0]	R/W[1:0]	STRB	DSACK[3:0]			SPACE[1:0]	IPL[2:0]		AVEC					
RESET:															
0	1	1	1	1	0	1	1	0	1	1	1	0	0	0	0

## D.2.21 Chip-Select Option Registers

**CSOR[0:10]** — Chip-Select Option Registers

**\$YFFA4E–YFFA76**

15	14	13	12	11	10	9	8	7	6	5	4	3	2	1	0
MODE	BYTE[1:0]	R/W[1:0]	STRB	DSACK[3:0]			SPACE[1:0]	IPL[2:0]		AVEC					
RESET:															
0	0	0	0	0	0	0	0	0	0	0	0	0	0	0	0

CSORBT and CSOR[0:10] contain parameters that support bootstrap operations from peripheral memory devices. Bit and field definitions for CSORBT and CSOR[0:10] are the same.

**MODE** — Asynchronous/Synchronous Mode

0 = Asynchronous mode selected.

1 = Synchronous mode selected.

In asynchronous mode, chip-select assertion is synchronized with  $\overline{AS}$  and  $\overline{DS}$ .

In synchronous mode, the  $\overline{DSACK}$  field is not used because a bus cycle is only performed as a synchronous operation. When a match condition occurs on a chip-select programmed for synchronous operation, the chip-select signals the EBI that an E-clock cycle is pending. Refer to **5.3 System Clock** for more information on ECLK.

**BYTE[1:0]** — Upper/Lower Byte Option

This field is used only when the chip-select 16-bit port option is selected in the pin assignment register. **Table D-14** shows upper/lower byte options.



**Table D-14 BYTE Field Bit Encoding**

BYTE[1:0]	Description
00	Disable
01	Lower byte
10	Upper byte
11	Both bytes

**R/W[1:0]**— Read/Write

This field causes a chip-select to be asserted only for a read, only for a write, or for both read and write. **Table D-15** shows the options.

**Table D-15 Read/Write Field Bit Encoding**

R/W[1:0]	Description
00	Disable
01	Read only
10	Write only
11	Read/Write

**STRB** — Address Strobe/Data Strobe

This bit controls the timing for assertion of a chip-select in asynchronous mode. Selecting address strobe causes the chip-select to be asserted synchronized with address strobe. Selecting data strobe causes the chip-select to be asserted synchronized with data strobe.

0 = Address strobe

1 = Data strobe

**DSACK[3:0]** — Data Strobe Acknowledge

This field specifies the source of  $\overline{DSACK}$  in asynchronous mode. It also allows the user to adjust bus timing with internal  $\overline{DSACK}$  generation by controlling the number of wait states that are inserted to optimize bus speed in a particular application. **Table D-16** shows the  $\overline{DSACK}[3:0]$  field encoding. The fast termination encoding (%1110) effectively corresponds to -1 wait states.

**Table D-16 DSACK Field Encoding**

DSACK[3:0]	Clock Cycles Required Per Access	Wait States Inserted Per Access
0000	3	0
0001	4	1
0010	5	2
0011	6	3
0100	7	4
0101	8	5
0110	9	6
0111	10	7
1000	11	8
1001	12	9
1010	13	10
1011	14	11
1100	15	12
1101	16	13
1110	2	Fast Termination
1111	—	External DSACK

**SPACE[1:0] — Address Space Select**

Use this option field to select an address space for the chip-select logic. The CPU32 normally operates in supervisor or user space, but interrupt acknowledge cycles must take place in CPU space. **Table D-17** shows address space bit encodings.

**Table D-17 Address Space Bit Encodings**

SPACE[1:0]	Address Space
00	CPU Space
01	User Space
10	Supervisor Space
11	Supervisor/User Space

**IPL[2:0] — Interrupt Priority Level**

When SPACE[1:0] is set for CPU space (%00), chip-select logic can be used for interrupt acknowledge. During an interrupt acknowledge cycle, the priority level on address lines ADDR[3:1] is compared to the value in IPL[2:0]. If the values are the same, a chip-select can be asserted, provided other option register conditions are met. **Table D-18** shows IPL[2:0] field encoding.

**Table D-18 Interrupt Priority Level Field Encoding**

IPL[2:0]	Interrupt Priority Level
000	Any Level
001	1
010	2
011	3
100	4
101	5
110	6
111	7

This field only affects the response of chip-selects and does not affect interrupt recognition by the CPU32.

#### $\overline{AVEC}$ — Autovector Enable

This field selects one of two methods of acquiring an interrupt vector during an interrupt acknowledge cycle. It is not usually used with a chip-select pin.

0 = External interrupt vector enabled

1 = Autovector enabled

If the chip select is configured to trigger on an interrupt acknowledge cycle (SPACE[1:0] = %00) and the  $\overline{AVEC}$  field is set to one, the chip-select automatically generates  $\overline{AVEC}$  in response to the interrupt acknowledge cycle. Otherwise, the vector must be supplied by the requesting device.

### D.2.22 Master Shift Registers

**TSTMSRA** — Master Shift Register A **\$YFFA30**  
Used for factory test only.

**TSTMSRB** — Master Shift Register B **\$YFFA32**  
Used for factory test only.

### D.2.23 Test Module Shift Count Register

**TSTSC** — Test Module Shift Count **\$YFFA34**  
Used for factory test only.

### D.2.24 Test Module Repetition Count Register

**TSTRC** — Test Module Repetition Count **\$YFFA36**  
Used for factory test only.

### D.2.25 Test Submodule Control Register

**CREG** — Test Submodule Control Register **\$YFFA38**  
Used for factory test only.

### D.2.26 Distributed Register

**DREG** — Distributed Register **\$YFFA3A**  
Used for factory test only.

### D.3 Standby RAM Module

**Table D-19** shows the SRAM address map. SRAM control registers are accessible at the supervisor privilege level only.

**Table D-19 SRAM Address Map**

Address <sup>1</sup>	15	0
\$YFFB40	RAM Module Configuration Register (RAMMCR)	
\$YFFB42	RAM Test Register (RAMTST)	
\$YFFB44	RAM Array Base Address Register High (RAMBAH)	
\$YFFB46	RAM Array Base Address Register Low (RAMBAL)	

NOTES:

1. Y = M111, where M is the logic state of the module mapping (MM) bit in the SIMCR.

#### D.3.1 RAM Module Configuration Register

**RAMMCR** — RAM Module Configuration Register

**\$YFFB40**

15				11		9	8	0							
STOP	0	0	0	RLCK	0	RASP[1:0]		NOT USED							
RESET:															
1	0	0	0	0	0	1	1	0	0	0	0	0	0	0	0

**STOP** — Low-Power Stop Mode Enable

0 = SRAM operates normally.

1 = SRAM enters low-power stop mode.

This bit controls whether SRAM operates normally or enters low-power stop mode. In low-power stop mode, the array retains its contents, but cannot be read or written.

**RLCK** — RAM Base Address Lock

0 = SRAM base address registers can be written.

1 = SRAM base address registers are locked.

RLCK defaults to zero on reset; it can be written once to one

**RASP[1:0]** — RAM Array Space

The RASP field limits access to the SRAM array to one of four CPU32 address spaces. Refer to **Table D-20**.

**Table D-20 RASP Encoding**

RASP[1:0]	Space
00	Unrestricted program and data
01	Unrestricted program
10	Supervisor program and data
11	Supervisor program

### D.3.2 RAM Test Register

**RAMTST** — RAM Test Register

**\$YFFB42**

Used for factory test only.

### D.3.3 Array Base Address Register High

**RAMBAH** — Array Base Address Register High

**\$YFFB44**

15	8	7	6	5	4	3	2	1	0						
NOT USED								ADDR 23	ADDR 22	ADDR 21	ADDR 20	ADDR 19	ADDR 18	ADDR 17	ADDR 16

RESET:

0    0    0    0    0    0    0    0    0

### D.3.4 Array Base Address Register Low

**RAMBAL** — Array Base Address Register Low

**\$YFFB46**

15	14	13	12	11	10	9	8	7	6	5	4	3	2	1	0
ADDR 15	ADDR 14	ADDR 13	ADDR 12	0	0	0	0	0	0	0	0	0	0	0	0

RESET:

0    0    0    0    0    0    0    0    0    0    0    0    0    0    0    0

RAMBAH and RAMBAL specify the SRAM array base address in the system memory map. They can only be written while the SRAM is in low-power stop mode (STOP = 1, the default out of reset) and the base address lock is disabled (RLCK = 0, the default out of reset). This prevents accidental remapping of the array.

## D.4 Masked ROM Module

The MRM is used only in the MC68376. **Table D-21** shows the MRM address map. MRM control registers are accessible in supervisor mode only.

The reset states shown for the MRM registers are for the generic (blank ROM) versions of the device. Several MRM register bit fields can be user-specified on a custom-masked ROM device. Contact a Motorola sales representative for information on ordering a custom ROM device.

**Table D-21 MRM Address Map**

Address	15	0
\$YFF820	Masked ROM Module Configuration Register (MRMCR)	
\$YFF822	Not Implemented	
\$YFF824	ROM Array Base Address High Register (ROMBAH)	
\$YFF826	ROM Array Base Address Low Register (ROMBAL)	
\$YFF828	Signature High Register (SIGHI)	
\$YFF82A	Signature Low Register (SIGLO)	
\$YFF82C	Not Implemented	
\$YFF82E	Not Implemented	
\$YFF830	ROM Bootstrap Word 0 (ROMBS0)	
\$YFF832	ROM Bootstrap Word 1 (ROMBS1)	
\$YFF834	ROM Bootstrap Word 2 (ROMBS2)	
\$YFF836	ROM Bootstrap Word 3 (ROMBS3)	
\$YFF838	Not Implemented	
\$YFF83A	Not Implemented	
\$YFF83C	Not Implemented	
\$YFF83E	Not Implemented	

### D.4.1 Masked ROM Module Configuration Register

**MRMCR** — Masked ROM Module Configuration Register **\$YFF820**

	15	14	13	12	11	10	9	8	7	6	5	4	3	2	1	0
STOP	0	0	BOOT	LOCK	EMUL	ASPC[1:0]	WAIT[1:0]	0	0	0	0	0	0	0	0	0
RESET:																
DATA14	0	0	1	0	0	1	1	1	1	0	0	0	0	0	0	0

#### STOP — Low-Power Stop Mode Enable

The reset state of the STOP bit is the complement of DATA14 state during reset. The ROM array base address cannot be changed unless the STOP bit is set.

0 = ROM array operates normally.

1 = ROM array operates in low-power stop mode.

#### NOTE

Unless DATA14 is pulled down during reset, the MRM will be enabled. On generic MC68376 devices (blank ROM), the MRM is enabled at address \$FF0000 (which is outside of the 1 Mbyte address range of  $\overline{CSBOOT}$ ). On these devices, the MRM should be disabled (since it is blank) by setting the STOP bit during system initialization.

### **BOOT**— Boot ROM Control

Reset state of **BOOT** is specified at mask time. Bootstrap operation is overridden if **STOP** = 1 at reset. This is a read-only bit.

0 = ROM responds to bootstrap word locations during reset vector fetch.

1 = ROM does not respond to bootstrap word locations during reset vector fetch.

### **LOCK** — Lock Registers

The reset state of **LOCK** is specified at mask time. If the reset state of the **LOCK** is zero, it can be set once after reset to allow protection of the registers after initialization. Once the **LOCK** bit is set, it cannot be cleared again until after a reset. **LOCK** protects the **ASPC** and **WAIT** fields, as well as the **ROMBAL** and **ROMBAH** registers. **ASPC**, **ROMBAL** and **ROMBAH** are also protected by the **STOP** bit.

0 = Write lock disabled. Protected registers and fields can be written.

1 = Write lock enabled. Protected registers and fields cannot be written.

### **EMUL** — Emulation Mode Control

0 = Normal ROM operation

The MC68376 does not support emulation mode, therefore, this bit reads zero. Writes have no effect.

### **ASPC[1:0]** — ROM Array Space

**ASPC** can be written only if **LOCK** = 0 and **STOP** = 1. **ASPC1** places the ROM array in either supervisor or unrestricted space. **ASPC0** determines if the array resides in program space only or with program and data space. The reset state of **ASPC[1:0]** is specified at mask time. **Table D-22** shows **ASPC[1:0]** encoding.

**Table D-22 ROM Array Space Field**

<b>ASPC[1:0]</b>	<b>State Specified</b>
00	Unrestricted program and data
01	Unrestricted program
10	Supervisor program and data
11	Supervisor program

### **WAIT[1:0]** — Wait States

**WAIT[1:0]** specifies the number of wait states inserted by the MRM during ROM array accesses. The reset state of **WAIT[1:0]** is specified at mask time. **WAIT[1:0]** can be written only if **LOCK** = 0 and **STOP** = 1. **Table D-23** shows **WAIT[1:0]** encoding.

**Table D-23 Wait States Field**

<b>WAIT[1:0]</b>	<b>Cycles per Transfer</b>
00	3
01	4
10	5
11	2

## D.4.2 ROM Array Base Address Register High

**ROMBAH** — ROM Array Base Address Register High **\$YFF824**

15	14	13	12	11	10	9	8	7	6	5	4	3	2	1	0
0	0	0	0	0	0	0	0	ADDR 23	ADDR 22	ADDR 21	ADDR 20	ADDR 19	ADDR 18	ADDR 17	ADDR 16

RESET:

1 1 1 1 1 1 1 1

## D.4.3 ROM Array Base Address Register Low

**ROMBAL** — ROM Array Base Address Register Low **\$YFF826**

15	14	13	12	11	10	9	8	7	6	5	4	3	2	1	0
ADDR 15	ADDR 14	ADDR 13	0	0	0	0	0	0	0	0	0	0	0	0	0

RESET:

0 0 0

ROMBAH and ROMBAL specify ROM array base address. The reset state of these registers is specified at mask time. They can only be written when STOP = 1 and LOCK = 0. This prevents accidental remapping of the array. Because the 8-Kbyte ROM array in the MC68376 must be mapped to an 8-Kbyte boundary, ROMBAL bits [12:0] always contains \$0000. ROMBAH ADDR[15:8] read zero.

## D.4.4 ROM Signature High Register

**RSIGHI** — ROM Signature High Register **\$YFF828**

15	14	13	12	11	10	9	8	7	6	5	4	3	2	1	0
NOT USED												RSP18	RSP17	RSP16	

RESET:

0 0 0 0 0 0 0 0 0 0 0 0 0 0 0 0

## D.4.5 ROM Signature Low Register

**RSIGLO** — ROM Signature Low Register **\$YFF82A**

15	14	13	12	11	10	9	8	7	6	5	4	3	2	1	0
RSP15	RSP14	RSP13	RSP12	RSP11	RSP10	RSP9	RSP8	RSP7	RSP6	RSP5	RSP4	RSP3	RSP2	RSP1	RSP0

RESET:

0 0 0 0 0 0 0 0 0 0 0 0 0 0 0 0

RSIGHI and RSIGLO specify a ROM signature pattern. A user-written signature identification algorithm allows identification of the ROM array content. The signature is specified at mask time and cannot be changed.



#### D.4.6 ROM Bootstrap Words

<b>ROMBS0</b> — ROM Bootstrap Word 0	<b>\$YFF830</b>
<b>ROMBS1</b> — ROM Bootstrap Word 1	<b>\$YFF832</b>
<b>ROMBS2</b> — ROM Bootstrap Word 2	<b>\$YFF834</b>
<b>ROMBS3</b> — ROM Bootstrap Word 3	<b>\$YFF836</b>

Typically, CPU32 reset vectors reside in non-volatile memory and are only fetched when the CPU32 comes out of reset. These four words can be used as reset vectors with the contents specified at mask time. The content of these words cannot be changed. On generic (blank ROM) MC68376 devices, ROMBS[0:3] are masked to \$0000. When the ROM on the MC68376 is masked with customer specific code, ROMBS[0:3] respond to system addresses \$000000 to \$000006 only during the reset vector fetch if  $\overline{BOOT} = 0$ .

## D.5 QADC Module

**Table D-24** shows the QADC address map. The column labeled “Access” indicates the privilege level at which the CPU32 must be operating to access the register. A designation of “S” indicates that supervisor mode is required. A designation of “S/U” indicates that the register can be programmed for either supervisor mode access or unrestricted access.

**Table D-24 QADC Address Map**

Access	Address <sup>1</sup>	15	8	7	0
S	\$YFF200	Module Configuration Register (QADCMCR)			
S	\$YFF202	Test Register (QADCTEST)			
S	\$YFF204	Interrupt Register (QADCINT)			
S/U	\$YFF206	Port A Data (PORTQA)		Port B Data (PORTQB)	
S/U	\$YFF208	Port Data Direction Register (DDRQA)			
S/U	\$YFF20A	Control Register 0 (QACR0)			
S/U	\$YFF20C	Control Register 1 (QACR1)			
S/U	\$YFF20E	Control Register 2 (QACR2)			
S/U	\$YFF210	Status Register (QASR)			
—	\$YFF212 – \$YFF22E	Reserved			
S/U	\$YFF230 – \$YFF27E	Conversion Command Word (CCW) Table			
—	\$YFF280 – \$YFF2AE	Reserved			
S/U	\$YFF2B0 – \$YFF2FE	Result Word Table Right Justified, Unsigned Result Register (RJURR)			
—	\$YFF300 – \$YFF32E	Reserved			
S/U	\$YFF330 – \$YFF37E	Result Word Table Left Justified, Signed Result Register (LJSRR)			
—	\$YFF380 – \$YFF3AE	Reserved			
S/U	\$YFF3B0 – \$YFF3FE	Result Word Table Left Justified, Unsigned Result Register (LJURR)			

NOTES:

1. Y = M111, where M is the logic state of the module mapping (MM) bit in SIMCR.

### D.5.1 QADC Module Configuration Register

#### QADCMCR — Module Configuration Register

**\$YFF200**

15	14	13	12	11	10	9	8	7	6	5	4	3	2	1	0
STOP	FRZ	NOT USED					SUPV	NOT USED			IARB[3:0]				

RESET:

0 0 1 0 0 0 0

#### STOP — Low-Power Stop Mode Enable

When the STOP bit is set, the clock signal to the QADC is disabled, effectively turning off the analog circuitry.

0 = Enable QADC clock.

1 = Disable QADC clock.

## FRZ — FREEZE Assertion Response

The FRZ bit determines whether or not the QADC responds to assertion of the IMB FREEZE signal.

0 = QADC ignores the IMB FREEZE signal.

1 = QADC finishes any current conversion, then freezes.

## SUPV — Supervisor/Unrestricted Data Space

The SUPV bit designates the assignable space as supervisor or unrestricted.

0 = Only the module configuration register, test register, and interrupt register are designated as supervisor-only data space. Access to all other locations is unrestricted.

1 = All QADC registers and tables are designated as supervisor-only data space.

## IARB[3:0] — Interrupt Arbitration ID

The IARB field is used to arbitrate between simultaneous interrupt requests of the same priority. Each module that can generate interrupt requests must be assigned a unique, non-zero IARB field value.

### D.5.2 QADC Test Register

#### QADCTEST — QADC Test Register

**\$YFF202**

Used for factory test only.

### D.5.3 QADC Interrupt Register

#### QADCINT — QADC Interrupt Register

**\$YFF204**

15	14	13	12	11	10	9	8	7	6	5	4	3	2	1	0
RSVD	IRLQ1[2:0]			RSVD	IRLQ2[2:0]			IVB[7:2]					IVB[1:0] <sup>1</sup>		

RESET:

0 0 0 0 0 0 0 0 0 0 0 0 1 1 1 1

NOTES:

1. Bits 1 and 0 are supplied by the QADC.

#### IRLQ1[2:0] — Queue 1 Interrupt Level

When queue 1 generates an interrupt request, IRLQ1[2:0] determines which of the interrupt request signals is asserted. When a request is acknowledged, the QADC compares IRLQ1[2:0] to a mask value supplied by the CPU32 to determine whether to respond. IRLQ1[2:0] must have a value in the range of \$0 (interrupts disabled) to \$7 (highest priority).

#### IRLQ2[2:0] — Queue 2 Interrupt Level

When queue 2 generates an interrupt request, IRLQ2[2:0] determines which of the interrupt request signals is asserted. When a request is acknowledged, the QADC compares IRLQ2[2:0] to a mask value supplied by the CPU32 to determine whether to respond. IRLQ2[2:0] must have a value in the range of \$0 (interrupts disabled) to \$7 (highest priority).

## IVB[7:0] — Interrupt Vector Base

Only the upper six bits of IVB[7:0] can be initialized. During interrupt arbitration, the vector provided by the QADC is made up of IVB[7:2], plus two low-order bits that identify one of the four QADC interrupt sources. Once IVB is written, the two low-order bits always read as zeros.

## D.5.4 Port A/B Data Register

**PORTQA** — Port QA Data Register

**\$YFF206**

**PORTQB** — Port QB Data Register

**\$YFF207**

15	14	13	12	11	10	9	8	7	6	5	4	3	2	1	0
PQA7	PQA6	PQA5	PQA4	PQA3	PQA2	PQA1	PQA0	PQB7	PQB6	PQB5	PQB4	PQB3	PQB2	PQB1	PQB0
RESET:															
U	U	U	U	U	U	U	U	U	U	U	U	U	U	U	U
ANALOG CHANNEL:															
AN59	AN58	AN57	AN56	AN55	AN54	AN53	AN52	AN51	AN50	AN49	AN48	AN3	AN2	AN1	AN0
EXTERNAL TRIGGER INPUTS:															
				ETRIG2	ETRIG1										
MULTIPLEXED ADDRESS OUTPUTS:															
						MA2	MA1	MA0							
MULTIPLEXED ANALOG INPUTS:															
												ANz	ANy	ANx	ANw

QADC ports A and B are accessed through two 8-bit port data registers (PORTQA and PORTQB). Port A pins are referred to as PQA[7:0] when used as an 8-bit input/output port. Port A can also be used for analog inputs (AN[59:52]), external trigger inputs (ETRIG[2:1]), and external multiplexer address outputs (MA[2:0]).

Port B pins are referred to as PQB[7:0] when used as an 8-bit input only port. Port B can also be used for non-multiplexed (AN[51:48])/AN[3:0]) and multiplexed (ANz, ANy, ANx, ANw) analog inputs.

## D.5.5 Port Data Direction Register

**DDRQA** — Port QA Data Direction Register

**\$YFF208**

15	14	13	12	11	10	9	8	7	6	5	4	3	2	1	0
DDQA7	DDQA6	DDQA5	DDQA4	DDQA3	DDQA2	DDQA1	DDQA0	RESERVED							
RESET:															
0	0	0	0	0	0	0	0	0	0	0	0	0	0	0	0

Bits in this register control the direction of the port QA pin drivers when pins are configured for I/O. Setting a bit configures the corresponding pin as an output; clearing a bit configures the corresponding pin as an input. This register can be read or written at any time.



## QACR1 — Control Register 1

\$YFF20C

15	14	13	12	11	10	9	8	7	6	5	4	3	2	1	0
CIE1	PIE1	SSE1	NOT USED	MQ1[2:0]			RESERVED								

RESET:

0 0 0 0 0 0 0

### CIE1 — Queue 1 Completion Interrupt Enable

CIE1 enables completion interrupts for queue 1. The interrupt request is generated when the conversion is complete for the last CCW in queue 1.

0 = Queue 1 completion interrupts disabled.

1 = Generate an interrupt request after completing the last CCW in queue 1.

### PIE1 — Queue 1 Pause Interrupt Enable

PIE1 enables pause interrupts for queue 1. The interrupt request is generated when the conversion is complete for a CCW that has the pause bit set.

0 = Queue 1 pause interrupts disabled.

1 = Generate an interrupt request after completing a CCW in queue 1 which has the pause bit set.

### SSE1 — Queue 1 Single-Scan Enable

SSE1 enables a single-scan of queue 1 after a trigger event occurs. The SSE1 bit may be set to a one during the same write cycle that sets the MQ1[2:0] bits for the single-scan queue operating mode. The single-scan enable bit can be written as a one or a zero, but is always read as a zero.

The SSE1 bit allows a trigger event to initiate queue execution for any single-scan operation on queue 1. The QADC clears SSE1 when the single-scan is complete.

### MQ1[2:0] — Queue 1 Operating Mode

The MQ1 field selects the queue operating mode for queue 1. **Table D-25** shows the different queue 1 operating modes.

**Table D-25 Queue 1 Operating Modes**

MQ1[2:0]	Queue 1 Operating Mode
000	Disabled mode, conversions do not occur
001	Software triggered single-scan mode (started with SSE1)
010	External trigger rising edge single-scan mode (on ETRIG1 pin)
011	External trigger falling edge single-scan mode (on ETRIG1 pin)
100	Reserved mode, conversions do not occur
101	Software triggered continuous-scan mode (started with SSE1)
110	External trigger rising edge continuous-scan mode (on ETRIG1 pin)
111	External trigger falling edge continuous-scan mode (on ETRIG1 pin)

## QACR2 — Control Register 2

\$YFF20E

15	14	13	12	11	10	9	8	7	6	5	4	3	2	1	0
CIE2	PIE2	SSE2	MQ2[4:0]				RES	NOT USED	BQ2[5:0]						

RESET:

0 0 0 0 0 0 0 0 0 1 0 0 1 1 1

### CIE2 — Queue 2 Completion Interrupt Enable

CIE2 enables completion interrupts for queue 2. The interrupt request is generated when the conversion is complete for the last CCW in queue 2.

0 = Queue 2 completion interrupts disabled.

1 = Generate an interrupt request after completing the last CCW in queue 2.

### PIE2 — Queue 2 Pause Interrupt Enable

PIE2 enables pause interrupts for queue 2. The interrupt request is generated when the conversion is complete for a CCW that has the pause bit set.

0 = Queue 2 pause interrupts disabled.

1 = Generate an interrupt request after completing a CCW in queue 2 which has the pause bit set.

### SSE2 — Queue 2 Single-Scan Enable Bit

SSE2 enables a single-scan of queue 2 after a trigger event occurs. The SSE2 bit may be set to a one during the same write cycle that sets the MQ2[4:0] bits for the single-scan queue operating mode. The single-scan enable bit can be written as a one or a zero, but is always read as a zero.

The SSE2 bit allows a trigger event to initiate queue execution for any single-scan operation on queue 2. The QADC clears SSE2 when the single-scan is complete.

### MQ2[4:0] — Queue 2 Operating Mode

The MQ2 field selects the queue operating mode for queue 2. **Table D-26** shows the bits in the MQ2 field which enable different queue 2 operating modes.

**Table D-26 Queue 2 Operating Modes**

<b>MQ2[4:0]</b>	<b>Queue 2 Operating Mode</b>
00000	Disabled mode, conversions do not occur
00001	Software triggered single-scan mode (started with SSE2)
00010	External trigger rising edge single-scan mode (on ETRIG2 pin)
00011	External trigger falling edge single-scan mode (on ETRIG2 pin)
00100	Interval timer single-scan mode: interval = QCLK period x 2 <sup>7</sup>
00101	Interval timer single-scan mode: interval = QCLK period x 2 <sup>8</sup>
00110	Interval timer single-scan mode: interval = QCLK period x 2 <sup>9</sup>
00111	Interval timer single-scan mode: interval = QCLK period x 2 <sup>10</sup>
01000	Interval timer single-scan mode: interval = QCLK period x 2 <sup>11</sup>
01001	Interval timer single-scan mode: interval = QCLK period x 2 <sup>12</sup>
01010	Interval timer single-scan mode: interval = QCLK period x 2 <sup>13</sup>
01011	Interval timer single-scan mode: interval = QCLK period x 2 <sup>14</sup>
01100	Interval timer single-scan mode: interval = QCLK period x 2 <sup>15</sup>
01101	Interval timer single-scan mode: interval = QCLK period x 2 <sup>16</sup>
01110	Interval timer single-scan mode: interval = QCLK period x 2 <sup>17</sup>
01111	Reserved mode
10000	Reserved mode
10001	Software triggered continuous-scan mode (started with SSE2)
10010	External trigger rising edge continuous-scan mode (on ETRIG2 pin)
10011	External trigger falling edge continuous-scan mode (on ETRIG2 pin)
10100	Periodic timer continuous-scan mode: period = QCLK period x 2 <sup>7</sup>
10101	Periodic timer continuous-scan mode: period = QCLK period x 2 <sup>8</sup>
10110	Periodic timer continuous-scan mode: period = QCLK period x 2 <sup>9</sup>
10111	Periodic timer continuous-scan mode: period = QCLK period x 2 <sup>10</sup>
11000	Periodic timer continuous-scan mode: period = QCLK period x 2 <sup>11</sup>
11001	Periodic timer continuous-scan mode: period = QCLK period x 2 <sup>12</sup>
11010	Periodic timer continuous-scan mode: period = QCLK period x 2 <sup>13</sup>
11011	Periodic timer continuous-scan mode: period = QCLK period x 2 <sup>14</sup>
11100	Periodic timer continuous-scan mode: period = QCLK period x 2 <sup>15</sup>
11101	Periodic timer continuous-scan mode: period = QCLK period x 2 <sup>16</sup>
11110	Periodic timer continuous-scan mode: period = QCLK period x 2 <sup>17</sup>
11111	Reserved mode

**RES — Queue 2 Resume**

RES selects the resumption point after queue 2 is suspended by queue 1. If RES is changed during execution of queue 2, the change is not recognized until an end-of-queue condition is reached, or the queue operating mode of queue 2 is changed.

0 = After suspension, begin execution with the first CCW in queue 2 or the current subqueue.

1 = After suspension, begin execution with the aborted CCW in queue 2.



BQ2[5:0] — Beginning of Queue 2

The BQ2 field indicates the location in the CCW table where queue 2 begins. The BQ2 field also indicates the end of queue 1 and thus creates an end-of-queue condition for queue 1.

### D.5.7 QADC Status Register

**QASR** — Status Register

**\$YFFF210**

15	14	13	12	11	10	9	8	7	6	5	4	3	2	1	0
CF1	PF1	CF2	PF2	TOR1	TOR2	QS[3:0]			CWP[5:0]						
RESET:															
0	0	0	0	0	0	0	0	0	0	0	0	0	0	0	0

**CF1** — Queue 1 Completion Flag

CF1 indicates that a queue 1 scan has been completed. CF1 is set by the QADC when the conversion is complete for the last CCW in queue 1, and the result is stored in the result table.

0 = Queue 1 scan is not complete.

1 = Queue 1 scan is complete.

**PF1** — Queue 1 Pause Flag

PF1 indicates that a queue 1 scan has reached a pause. PF1 is set by the QADC when the current queue 1 CCW has the pause bit set, the selected input channel has been converted, and the result has been stored in the result table.

0 = Queue 1 has not reached a pause.

1 = Queue 1 has reached a pause.

**CF2** — Queue 2 Completion Flag

CF2 indicates that a queue 2 scan has been completed. CF2 is set by the QADC when the conversion is complete for the last CCW in queue 2, and the result is stored in the result table.

0 = Queue 2 scan is not complete.

1 = Queue 2 scan is complete.

**PF2** — Queue 2 Pause Flag

PF2 indicates that a queue 2 scan has reached a pause. PF2 is set by the QADC when the current queue 2 CCW has the pause bit set, the selected input channel has been converted, and the result has been stored in the result table.

0 = Queue 2 has not reached a pause.

1 = Queue 2 has reached a pause.

**TOR1** — Queue 1 Trigger Overrun

TOR1 indicates that an unexpected queue 1 trigger event has occurred. TOR1 can be set only while queue 1 is active.

A trigger event generated by a transition on ETRIG1 may be recorded as a trigger overrun. TOR1 can only be set when using an external trigger mode. TOR1 cannot occur when the software initiated single-scan mode or the software initiated continuous-scan mode is selected.

- 0 = No unexpected queue 1 trigger events have occurred.
- 1 = At least one unexpected queue 1 trigger event has occurred.

**TOR2 — Queue 2 Trigger Overrun**

TOR2 indicates that an unexpected queue 2 trigger event has occurred. TOR2 can be set when queue 2 is in the active, suspended, and trigger pending states.

A trigger event generated by a transition on ETRIG2 or by the periodic/interval timer may be recorded as a trigger overrun. TOR2 can only be set when using an external trigger mode or a periodic/interval timer mode. Trigger overruns cannot occur when the software initiated single-scan mode and the software initiated continuous-scan mode are selected.

- 0 = No unexpected queue 2 trigger events have occurred.
- 1 = At least one unexpected queue 2 trigger event has occurred.

**QS[3:0] — Queue Status**

This 4-bit read-only field indicates the current condition of queue 1 and queue 2. QS[3:2] are associated with queue 1, and QS[1:0] are associated with queue 2. Since the queue priority scheme interlinks the operation of queue 1 and queue 2, the status bits should be considered as one 4-bit field.

**Table D-27** shows the bit encodings of the QS field.

**Table D-27 Queue Status**

QS[3:0]	Description
0000	Queue 1 idle, Queue 2 idle
0001	Queue 1 idle, Queue 2 paused
0010	Queue 1 idle, Queue 2 active
0011	Queue 1 idle, Queue 2 trigger pending
0100	Queue 1 paused, Queue 2 idle
0101	Queue 1 paused, Queue 2 paused
0110	Queue 1 paused, Queue 2 active
0111	Queue 1 paused, Queue 2 trigger pending
1000	Queue 1 active, Queue 2 idle
1001	Queue 1 active, Queue 2 paused
1010	Queue 1 active, Queue 2 suspended
1011	Queue 1 active, Queue 2 trigger pending
1100	Reserved
1101	Reserved
1110	Reserved
1111	Reserved

**CWP[5:0] — Command Word Pointer**

CWP indicates which CCW is executing at present, or was last completed. The CWP is a read-only field; writes to it have no effect. The CWP allows software to monitor the progress of the QADC scan sequence. The CWP field is a CCW word pointer with a valid range of 0 to 39.

## D.5.8 Conversion Command Word Table

### CCW[0:27] — Conversion Command Word Table

\$YFF230–\$YFF27E

15	14	13	12	11	10	9	8	7	6	5	4	3	2	1	0
NOT USED						P	BYP	IST[1:0]	CHAN[5:0]						
RESET:															
						U	U	U	U	U	U	U	U	U	U

#### P — Pause

The pause bit allows the creation of sub-queues within queue 1 and queue 2. The QADC performs the conversion specified by the CCW with the pause bit set, and then the queue enters the pause state. Another trigger event causes execution to continue from the pause to the next CCW.

- 0 = Do not enter the pause state after execution of the current CCW.
- 1 = Enter the pause state after execution of the current CCW.

#### BYP — Sample Amplifier Bypass

Setting BYP enables the amplifier bypass mode for a conversion, and subsequently changes the timing. Refer to **8.11.1.1 Amplifier Bypass Mode Conversion Timing** for more information.

- 0 = Amplifier bypass mode disabled.
- 1 = Amplifier bypass mode enabled.

#### IST[1:0] — Input Sample Time

The IST field specifies the length of the sample window. Longer sample times permit more accurate A/D conversions of signals with higher source impedances.

**Table D-28** shows the bit encoding of the IST field.

**Table D-28 Input Sample Times**

IST[1:0]	Input Sample Times
00	2 QCLK periods
01	4 QCLK periods
10	8 QCLK periods
11	16 QCLK periods

#### CHAN[5:0] — Channel Number

The CHAN field selects the input channel number corresponding to the analog input pin to be sampled and converted. The analog input pin channel number assignments and the pin definitions vary depending on whether the QADC is operating in multiplexed or non-multiplexed mode. The queue scan mechanism sees no distinction between an internally or externally multiplexed analog input.

CHAN specifies a reserved channel number (channels 32 to 47) or an invalid channel number (channels 4 to 31 in non-multiplexed mode), the low reference level ( $V_{RL}$ ) is converted. Programming the channel field to channel 63 indicates the end of the queue. Channels 60 to 62 are special internal channels. When one of these channels is selected, the sample amplifier is not used. The value of  $V_{RL}$ ,  $V_{RH}$ , or  $V_{DDA}/2$  is placed directly onto the converter. Programming the input sample time to any value other than two for one of the internal channels has no benefit except to lengthen the overall conversion time.

Table D-29 shows the channel number assignments for the non-multiplexed mode. Table D-30 shows the channel number assignments for the multiplexed mode.

**Table D-29 Non-multiplexed Channel Assignments and Pin Designations**

Non-multiplexed Input Pins				Channel Number in CHAN[5:0]	
Port Pin Name	Analog Pin Name	Other Functions	Pin Type	Binary	Decimal
PQB0	AN0	—	Input	000000	0
PQB1	AN1	—	Input	000001	1
PQB2	AN2	—	Input	000010	2
PQB3	AN3	—	Input	000011	3
—	—	Invalid	—	000100 to 011111	4 to 31
—	—	Reserved	—	10XXXX	32 to 47
PQB4	AN48	—	Input	110000	48
PQB5	AN49	—	Input	110001	49
PQB6	AN50	—	Input	110010	50
PQB7	AN51	—	Input	110011	51
PQA0	AN52	—	Input/Output	110100	52
PQA1	AN53	—	Input/Output	110101	53
PQA2	AN54	—	Input/Output	110110	54
PQA3	AN55	ETRIG1	Input/Output	110111	55
PQA4	AN56	ETRIG2	Input/Output	111000	56
PQA5	AN57	—	Input/Output	111001	57
PQA6	AN58	—	Input/Output	111010	58
PQA7	AN59	—	Input/Output	111011	59
—	V <sub>RL</sub>	—	Input	111100	60
—	V <sub>RH</sub>	—	Input	111101	61
—	—	V <sub>DDA</sub> /2	—	111110	62
—	—	End of Queue Code	—	111111	63

**Table D-30 Multiplexed Channel Assignments and Pin Designations**

Multiplexed Input Pins				Channel Number in CHAN[5:0]	
Port Pin Name	Analog Pin Name	Other Functions	Pin Type	Binary	Decimal
PQB0	ANw	—	Input	00xxx0	0 to 14 even
PQB1	ANx	—	Input	00xxx1	1 to 15 odd
PQB2	ANy	—	Input	01xxx0	16 to 30 even
PQB3	ANz	—	Input	01xxx1	17 to 31 odd
—	—	Reserved	—	10xxxx	32 to 47
PQB4	AN48	—	Input	110000	48
PQB5	AN49	—	Input	110001	49
PQB6	AN50	—	Input	110010	50
PQB7	AN51	—	Input	110011	51
PQA0	—	MA0	Input/Output	110100	52
PQA1	—	MA1	Input/Output	110101	53
PQA2	—	MA2	Input/Output	110110	54
PQA3	AN55	ETRIG1	Input/Output	110111	55
PQA4	AN56	ETRIG2	Input/Output	111000	56
PQA5	AN57	—	Input/Output	111001	57
PQA6	AN58	—	Input/Output	111010	58
PQA7	AN59	—	Input/Output	111011	59
—	V <sub>RL</sub>	—	Input	111100	60
—	V <sub>RH</sub>	—	Input	111101	61
—	—	V <sub>DDA</sub> /2	—	111110	62
—	—	End of Queue Code	—	111111	63

### D.5.9 Result Word Table

The result word table is a 40-word long, 10-bit wide RAM. An entry is written by the QADC after completing an analog conversion specified by the corresponding CCW table entry. The result word table can be read or written, but is only read in normal operation to obtain analog conversions results from the QADC. Unimplemented bits are read as zeros, and writes to them do not have any effect.

#### RJURR[0:27] — Right Justified, Unsigned Result Register \$YFF2B0–\$YFF2FE

15	14	13	12	11	10	9	8	7	6	5	4	3	2	1	0
NOT USED								RESULT							

The conversion result is unsigned, right justified data stored in bits [9:0]. Bits [15:10] return zero when read.

#### LJSRR[0:27] — Left Justified, Signed Result Register \$YFF330–\$YFF37E

15	14	13	12	11	10	9	8	7	6	5	4	3	2	1	0
S <sup>1</sup>	RESULT								NOT USED						

NOTES:

1. S = Sign bit.

The conversion result is signed, left justified data stored in bits [15:6], with the MSB inverted to form a sign bit. Bits [5:0] return zero when read.

#### LJURR[0:27] — Left Justified, Unsigned Result Register \$YFF3B0–\$YFF3FE

15	14	13	12	11	10	9	8	7	6	5	4	3	2	1	0
RESULT										NOT USED					

The conversion result is unsigned, left justified data stored in bits [15:6]. Bits [5:0] return zero when read.

## D.6 Queued Serial Module

**Table D-31** shows the QSM address map. The column labeled “Access” indicates the privilege level at which the CPU32 must be operating to access the register. A designation of “S” indicates that supervisor mode is required. A designation of “S/U” indicates that the register can be programmed for either supervisor mode access or unrestricted access.

**Table D-31 QSM Address Map**

Access	Address <sup>1</sup>	15	8	7	0
S	\$YFFC00	QSM Module Configuration Register (QSMCR)			
S	\$YFFC02	QSM Test Register (QTEST)			
S	\$YFFC04	QSM Interrupt Level Register (QILR)		QSM Interrupt Vector Register (QIVR)	
S/U	\$YFFC06	Not Used			
S/U	\$YFFC08	SCI Control 0 Register (SCCR0)			
S/U	\$YFFC0A	SCI Control 1 Register (SCCR1)			
S/U	\$YFFC0C	SCI Status Register (SCSR)			
S/U	\$YFFC0E	SCI Data Register (SCDR)			
S/U	\$YFFC10	Not Used			
S/U	\$YFFC12	Not Used			
S/U	\$YFFC14	Not Used		PQS Data Register (PORTQS)	
S/U	\$YFFC16	PQS Pin Assignment Register (PQSPAR)		PQS Data Direction Register (DDRQS)	
S/U	\$YFFC18	SPI Control Register 0 (SPCR0)			
S/U	\$YFFC1A	SPI Control Register 1 (SPCR1)			
S/U	\$YFFC1C	SPI Control Register 2 (SPCR2)			
S/U	\$YFFC1E	SPI Control Register 3 (SPCR3)		SPI Status Register (SPSR)	
S/U	\$YFFC20 – \$YFFCFF	Not Used			
S/U	\$YFFD00 – \$YFFD1F	Receive RAM (RR[0:F])			
S/U	\$YFFD20 – \$YFFD3F	Transmit RAM (TR[0:F])			
S/U	\$YFFD40 – \$YFFD4F	Command RAM (CR[0:F])			

**NOTES:**

1. Y = M111, where M is the logic state of the module mapping (MM) bit in the SIMCR.

### D.6.1 QSM Configuration Register

#### QSMCR — QSM Configuration Register

**\$YFFC00**

15	14	13	12	11	10	9	8	7	6	5	4	3	2	1	0
STOP	FRZ1	FRZ0	0	0	0	0	0	SUPV	0	0	0	IARB[3:0]			

RESET:

0	0	0	0	0	0	0	0	0	1	0	0	0	0	0	0
---	---	---	---	---	---	---	---	---	---	---	---	---	---	---	---

QSMCR bits enable stop and freeze modes, and determine the arbitration priority of QSM interrupt requests.

**STOP** — Low-Power Stop Mode Enable  
 0 = QSM clock operates normally.  
 1 = QSM clock is stopped.

When STOP is set, the QSM enters low-power stop mode. The system clock input to the module is disabled. While STOP is set, only QSMCR reads are guaranteed to be valid, but writes to the QSPI RAM and other QSM registers are guaranteed valid. The SCI receiver and transmitter must be disabled before STOP is set. To stop the QSPI, set the HALT bit in SPCR3, wait until the HALTA flag is set, then set STOP.

**FRZ1**— FREEZE Assertion Response

FRZ1 determines what action is taken by the QSPI when the IMB FREEZE signal is asserted.

0 = Ignore the IMB FREEZE signal.  
 1 = Halt the QSPI on a transfer boundary.

**FRZ0** — Not Implemented

Bits [12:8] — Not Implemented

**SUPV** — Supervisor/Unrestricted Data Space

The SUPV bit places the QSM registers in either supervisor or user data space.

0 = Registers with access controlled by the SUPV bit are accessible in either supervisor or user mode.  
 1 = Registers with access controlled by the SUPV bit are restricted to supervisor access only.

Bits [6:4] — Not Implemented

**IARB[3:0]** — Interrupt Arbitration ID

The IARB field is used to arbitrate between simultaneous interrupt requests of the same priority. Each module that can generate interrupt requests must be assigned a unique, non-zero IARB field value.

## D.6.2 QSM Test Register

**QTEST** — QSM Test Register

**\$YFFC02**

Used for factory test only.

## D.6.3 QSM Interrupt Level Register

**QILR** — QSM Interrupt Levels Register

**\$YFFC04**

15	14	13	12	11	10	9	8	7	6	5	4	3	2	1	0
0	0	ILQSPI[2:0]			ILSCI[2:0]			QIVR							
RESET:															
0	0	0	0	0	0	0	0	0	0	0	0	0	0	0	0

The values of ILQSPI[2:0] and ILSCI[2:0] in QILR determine the priority of QSPI and SCI interrupt requests.

### ILQSPI[2:0] — Interrupt Level for QSPI

When an interrupt request is made, ILQSPI value determines which of the interrupt request signals is asserted; when a request is acknowledged, the QSM compares this value to a mask value supplied by the CPU32 to determine whether to respond. ILQSPI must have a value in the range \$0 (interrupts disabled) to \$7 (highest priority).

### ILSCI[2:0] — Interrupt Level for SCI

When an interrupt request is made, ILSCI value determines which of the interrupt request signals is asserted. When a request is acknowledged, the QSM compares this value to a mask value supplied by the CPU32 to determine whether to respond. The field must have a value in the range \$0 (interrupts disabled) to \$7 (highest priority).

If ILQSPI[2:0] and ILSCI[2:0] have the same non-zero value, and both submodules simultaneously request interrupt service, the QSPI has priority.

## D.6.4 QSM Interrupt Vector Register

### QIVR — QSM Interrupt Vector Register

**\$YFFC05**

15	14	13	12	11	10	9	8	7	6	5	4	3	2	1	0		
QILR								INTV[7:0]									
RESET:																	
								0	0	0	0	1	1	1	1		

QIVR determines the value of the interrupt vector number the QSM supplies when it responds to an interrupt acknowledge cycle. At reset, QIVR is initialized to \$0F, the uninitialized interrupt vector number. To use interrupt-driven serial communication, a user-defined vector number must be written to QIVR.

### INTV[7:0] — Interrupt Vector Number

The values of INTV[7:1] are the same for both QSPI and SCI interrupt requests; the value of INTV0 used during an interrupt acknowledge cycle is supplied by the QSM. INTV0 is at logic level zero during an SCI interrupt and at logic level one during a QSPI interrupt. A write to INTV0 has no effect. Reads of INTV0 return a value of one.

## D.6.5 SCI Control Register

### SCCR0 — SCI Control Register 0

**\$YFFC08**

15	13	12	11	10	9	8	7	6	5	4	3	2	1	0	
NOT USED			SCBR[12:0]												
RESET:															
0	0	0	0	0	0	0	0	0	0	0	0	0	0	1	0

SCCR0 contains the SCI baud rate selection field. Baud rate must be set before the SCI is enabled. The CPU32 can read and write SCCR0 at any time. Changing the value of SCCR0 bits during a transfer operation can disrupt the transfer.

### Bits [15:13] — Not Implemented



## SCBR[12:0] — SCI Baud Rate

SCI baud rate is programmed by writing a 13-bit value to this field. Writing a value of zero to SCBR disables the baud rate generator. Baud clock rate is calculated as follows:

$$\text{SCI Baud Rate} = \frac{f_{\text{sys}}}{32 \times \text{SCBR}[12:0]}$$

or

$$\text{SCBR}[12:0] = \frac{f_{\text{sys}}}{32 \times \text{SCI Baud Rate Desired}}$$

where SCBR[12:0] is in the range of 1 to 8191.

## D.6.6 SCI Control Register 1

### SCCR1 — SCI Control Register 1

**\$YFFC0A**

15	14	13	12	11	10	9	8	7	6	5	4	3	2	1	0
0	LOOPS	WOMS	ILT	PT	PE	M	WAKE	TIE	TCIE	RIE	ILIE	TE	RE	RWU	SBK

RESET:

0 0 0 0 0 0 0 0 0 0 0 0 0 0 0 0

SCCR1 contains SCI configuration parameters, including transmitter and receiver enable bits, interrupt enable bits, and operating mode enable bits. SCCR0 can be read or written at any time. The SCI can modify the RWU bit under certain circumstances. Changing the value of SCCR1 bits during a transfer operation can disrupt the transfer.

Bit 15 — Not Implemented

LOOPS — Loop Mode

0 = Normal SCI operation, no looping, feedback path disabled.

1 = Test SCI operation, looping, feedback path enabled.

WOMS — Wired-OR Mode for SCI Pins

0 = If configured as an output, TXD is a normal CMOS output.

1 = If configured as an output, TXD is an open-drain output.

ILT — Idle-Line Detect Type

0 = Short idle-line detect (start count on first one).

1 = Long idle-line detect (start count on first one after stop bit(s)).

PT — Parity Type

0 = Even parity

1 = Odd parity

PE — Parity Enable

0 = SCI parity disabled.

1 = SCI parity enabled.

- M — Mode Select  
0 = 10-bit SCI frame  
1 = 11-bit SCI frame
- WAKE — Wakeup by Address Mark  
0 = SCI receiver awakened by idle-line detection.  
1 = SCI receiver awakened by address mark (last bit set).
- TIE — Transmit Interrupt Enable  
0 = SCI TDRE interrupts disabled.  
1 = SCI TDRE interrupts enabled.
- TCIE — Transmit Complete Interrupt Enable  
0 = SCI TC interrupts disabled.  
1 = SCI TC interrupts enabled.
- RIE — Receiver Interrupt Enable  
0 = SCI RDRF and OR interrupts disabled.  
1 = SCI RDRF and OR interrupts enabled.
- ILIE — Idle-Line Interrupt Enable  
0 = SCI IDLE interrupts disabled.  
1 = SCI IDLE interrupts enabled.
- TE — Transmitter Enable  
0 = SCI transmitter disabled (TXD pin can be used as I/O).  
1 = SCI transmitter enabled (TXD pin dedicated to SCI transmitter).
- RE — Receiver Enable  
0 = SCI receiver disabled.  
1 = SCI receiver enabled.
- RWU — Receiver Wakeup  
0 = Normal receiver operation (received data recognized).  
1 = Wakeup mode enabled (received data ignored until receiver is awakened).
- SBK — Send Break  
0 = Normal operation  
1 = Break frame(s) transmitted after completion of current frame.

## D.6.7 SCI Status Register

### SCSR — SCI Status Register

**\$YFFC0C**

15	9	8	7	6	5	4	3	2	1	0								
NOT USED									TDRE	TC	RDRF	RAF	IDLE	OR	NF	FE	PF	
RESET:																		
0	0	0	0	0	0	0	0	0	0	0	1	1	0	0	0	0	0	0

SCSR contains flags that show SCI operating conditions. These flags are cleared either by SCI hardware or by a read/write sequence. The sequence consists of reading SCSR, then reading or writing SCDR.

If an internal SCI signal for setting a status bit comes after reading the asserted status bits, but before writing or reading SCDR, the newly set status bit is not cleared. SCSR must be read again with the bit set and SCDR must be read or written before the status bit is cleared.

A long-word read can consecutively access both SCSR and SCDR. This action clears receive status flag bits that were set at the time of the read, but does not clear TDRE or TC flags. Reading either byte of SCSR causes all 16 bits to be accessed, and any status bit already set in either byte is cleared on a subsequent read or write of SCDR.

#### TDRE — Transmit Data Register Empty

- 0 = Transmit data register still contains data to be sent to the transmit serial shifter.
- 1 = A new character can now be written to the transmit data register.

#### TC — Transmit Complete

- 0 = SCI transmitter is busy.
- 1 = SCI transmitter is idle.

#### RDRF — Receive Data Register Full

- 0 = Receive data register is empty or contains previously read data.
- 1 = Receive data register contains new data.

#### RAF — Receiver Active

- 0 = SCI receiver is idle.
- 1 = SCI receiver is busy.

#### IDLE — Idle-Line Detected

- 0 = SCI receiver did not detect an idle-line condition.
- 1 = SCI receiver detected an idle-line condition.

#### OR — Overrun Error

- 0 = Receive data register is empty and can accept data from the receive serial shifter.
- 1 = Receive data register is full and cannot accept data from the receive serial shifter. Any data in the shifter is lost and RDRF remains set.

#### NF — Noise Error Flag

- 0 = No noise detected in the received data.
- 1 = Noise detected in the received data.

FE — Framing Error

0 = No framing error detected in the received data.

1 = Framing error or break detected in the received data.

PF — Parity Error

0 = No parity error detected in the received data.

1 = Parity error detected in the received data.

## D.6.8 SCI Data Register

**SCDR** — SCI Data Register

**\$YFFC0E**

15		9	8	7	6	5	4	3	2	1	0
NOT USED			R8/T8	R7/T7	R6/T6	R5/T5	R4/T4	R3/T3	R2/T2	R1/T1	R0/T0
RESET:											
0	0	0	0	0	0	0	0	U	U	U	U

SCDR consists of two data registers located at the same address. The receive data register (RDR) is a read-only register that contains data received by the SCI serial interface. Data comes into the receive serial shifter and is transferred to RDR. The transmit data register (TDR) is a write-only register that contains data to be transmitted. Data is first written to TDR, then transferred to the transmit serial shifter, where additional format bits are added before transmission. R[7:0]/T[7:0] contain either the first eight data bits received when SCDR is read, or the first eight data bits to be transmitted when SCDR is written. R8/T8 are used when the SCI is configured for nine-bit operation. When the SCI is configured for 8-bit operation, R8/T8 have no meaning or effect.

## D.6.9 Port QS Data Register

**PORTQS** — Port QS Data Register

**\$YFFC15**

15		8	7	6	5	4	3	2	1	0
NOT USED			PQS7	PQS6	PQS5	PQS4	PQS3	PQS2	PQS1	PQS0
RESET:										
			0	0	0	0	0	0	0	0

PORTQS latches I/O data. Writes drive pins defined as outputs. Reads return data present on the pins. To avoid driving undefined data, first write a byte to PORTQS, then configure DDRQS.

## D.6.10 Port QS Pin Assignment Register/Data Direction Register

**PQSPAR** — PORT QS Pin Assignment Register

**\$YFFC16**

**DDRQS** — PORT QS Data Direction Register

**\$YFFC17**

15	14	13	12	11	10	9	8	7	6	5	4	3	2	1	0
0	PQSPA6	PQSPA5	PQSPA4	PQSPA3	0	PQSPA1	PQSPA0	DDQS7	DDQS6	DDQS5	DDQS4	DDQS3	DDQS2	DDQS1	DDQS0
RESET:															
0	0	0	0	0	0	0	0	0	0	0	0	0	0	0	0

Clearing a bit in PQSPAR assigns the corresponding pin to general-purpose I/O; setting a bit assigns the pin to the QSPI. PQSPAR does not affect operation of the SCI.

**Table D-32** displays PQSPAR pin assignments.

**Table D-32 PQSPAR Pin Assignments**

PQSPAR Field	PQSPAR Bit	Pin Function
PQSPA0	0	PQS0
	1	MISO
PQSPA1	0	PQS1
	1	MOSI
—	—	PQS2 <sup>1</sup>
	—	SCK
PQSPA3	0	PQS3
	1	PCS0/ $\overline{SS}$
PQSPA4	0	PQS4
	1	PCS1
PQSPA5	0	PQS5
	1	PCS2
PQSPA6	0	PQS6
	1	PCS3
—	—	PQS7 <sup>2</sup>
	—	TXD

NOTES:

1. PQS2 is a digital I/O pin unless the SPI is enabled (SPE in SPCR1 set), in which case it becomes the QSPI serial clock SCK.
2. PQS7 is a digital I/O pin unless the SCI transmitter is enabled (TE in SCCR1 = 1), in which case it becomes the SCI serial output TXD.

DDRQS determines whether pins configured for general purpose I/O are inputs or outputs. Clearing a bit makes the corresponding pin an input; setting a bit makes the pin an output. DDRQS affects both QSPI function and I/O function. **Table D-33** shows the effect of DDRQS on QSM pin function.

**Table D-33 Effect of DDRQS on QSM Pin Function**

QSM Pin	Mode	DDRQS Bit	Bit State	Pin Function
MISO	Master	DDQS0	0	Serial data input to QSPI
			1	Disables data input
	Slave		0	Disables data output
			1	Serial data output from QSPI
MOSI	Master	DDQS1	0	Disables data output
			1	Serial data output from QSPI
	Slave		0	Serial data input to QSPI
			1	Disables data input
SCK <sup>1</sup>	Master	DDQS2	—	Clock output from QSPI
	Slave		—	Clock input to QSPI
PCS0/SS	Master	DDQS3	0	Assertion causes mode fault
			1	Chip-select output
	Slave		0	QSPI slave select input
			1	Disables slave select Input
PCS[1:3]	Master	DDQS[4:6]	0	Disables chip-select output
			1	Chip-select output
	Slave		0	Inactive
			1	Inactive
TXD <sup>2</sup>	—	DDQS7	X	Serial data output from SCI
RXD	—	None	NA	Serial data input to SCI

NOTES:

1. PQS2 is a digital I/O pin unless the SPI is enabled (SPE set in SPCR1), in which case it becomes the QSPI serial clock SCK.
2. PQS7 is a digital I/O pin unless the SCI transmitter is enabled (TE set in SCCR1), in which case it becomes the SCI serial data output TXD.

DDRQS determines the direction of the TXD pin only when the SCI transmitter is disabled. When the SCI transmitter is enabled, the TXD pin is an output.

### D.6.11 QSPI Control Register 0

#### SPCR0 — QSPI Control Register 0

**\$YFFC18**

15	14	13	12	11	10	9	8	7	6	5	4	3	2	1	0
MSTR	WOMQ	BITS[3:0]				CPOL	CPHA	SPBR[7:0]							

RESET:

0 0 0 0 0 0 0 1 0 0 0 0 0 0 1 0 0

SPCR0 contains parameters for configuring the QSPI and enabling various modes of operation. The CPU32 has read/write access to SPCR0, but the QSM has read access only. SPCR0 must be initialized before QSPI operation begins. Writing a new value to SPCR0 while the QSPI is enabled disrupts operation.

#### MSTR — Master/Slave Mode Select

0 = QSPI is a slave device.

1 = QSPI is the system master.

#### WOMQ — Wired-OR Mode for QSPI Pins

0 = Pins designated for output by DDRQS operate in normal mode.

1 = Pins designated for output by DDRQS operate in open-drain mode.

### **BITS[3:0] — Bits Per Transfer**

In master mode, when BITSE is set in a command RAM byte, BITS[3:0] determines the number of data bits transferred. When BITSE is cleared, eight bits are transferred. Reserved values default to eight bits. In slave mode, the command RAM is not used and the setting of BITSE has no effect on QSPI transfers. Instead, the BITS[3:0] field determines the number of bits the QSPI will receive during each transfer before storing the received data.

**Table D-34** shows the number of bits per transfer.

**Table D-34 Bits Per Transfer**

<b>BITS[3:0]</b>	<b>Bits per Transfer</b>
0000	16
0001	Reserved
0010	Reserved
0011	Reserved
0100	Reserved
0101	Reserved
0110	Reserved
0111	Reserved
1000	8
1001	9
1010	10
1011	11
1100	12
1101	13
1110	14
1111	15

### **CPOL — Clock Polarity**

0 = The inactive state of SCK is logic zero.

1 = The inactive state of SCK is logic one.

CPOL is used to determine the inactive state of the serial clock (SCK). It is used with CPHA to produce a desired clock/data relationship between master and slave devices.

### **CPHA — Clock Phase**

0 = Data is captured on the leading edge of SCK and changed on the trailing edge of SCK.

1 = Data is changed on the leading edge of SCK and captured on the trailing edge of SCK

CPHA determines which edge of SCK causes data to change and which edge causes data to be captured. CPHA is used with CPOL to produce a desired clock/data relationship between master and slave devices.

### **SPBR[7:0] — Serial Clock Baud Rate**

The QSPI uses a modulus counter to derive the SCK baud rate from the MCU system clock. Baud rate is selected by writing a value from 2 to 255 into SPBR[7:0]. The following equation determines the SCK baud rate:

$$\text{SCK Baud Rate} = \frac{f_{\text{sys}}}{2 \times \text{SPBR}[7:0]}$$

or

$$\text{SPBR}[7:0] = \frac{f_{\text{sys}}}{2 \times \text{SCK Baud Rate Desired}}$$

Giving SPBR[7:0] a value of zero or one disables the baud rate generator. SCK is disabled and assumes its inactive state value. No serial transfers occur. At reset, the SCK baud rate is initialized to one eighth of the system clock frequency.

## D.6.12 QSPI Control Register 1

### SPCR1 — QSPI Control Register 1

**\$YFFC1A**

15	14	13	12	11	10	9	8	7	6	5	4	3	2	1	0	
SPE	DSCKL[6:0]						DTL[7:0]									
RESET:																
0	0	0	0	0	1	0	0	0	0	0	0	0	0	1	0	0

SPCR1 enables the QSPI and specified transfer delays. The CPU32 has read/write access to SPCR1, but the QSM has read access only to all bits except SPE. SPCR1 must be written last during initialization because it contains SPE. Writing a new value to SPCR1 while the QSPI is enabled disrupts operation.

#### SPE — QSPI Enable

0 = QSPI is disabled. QSPI pins can be used for general-purpose I/O.

1 = QSPI is enabled. Pins allocated by PQSPAR are controlled by the QSPI.

#### DSCKL[6:0] — Delay before SCK

When the DSCK bit is set in a command RAM byte, this field determines the length of the delay from PCS valid to SCK transition. PCS can be any of the four peripheral chip-select pins. The following equation determines the actual delay before SCK:

$$\text{PCS to SCK Delay} = \frac{\text{DSCKL}[6:0]}{f_{\text{sys}}}$$

where DSCKL[6:0] equals is in the range of 1 to 127.

When DSCK is zero in a command RAM byte, then DSCKL[6:0] is not used. Instead, the PCS valid to SCK transition is one-half the SCK period.



### DTL[7:0] — Length of Delay after Transfer

When the DT bit is set in a command RAM byte, this field determines the length of the delay after a serial transfer. The following equation is used to calculate the delay:

$$\text{Delay after Transfer} = \frac{32 \times \text{DTL}[7:0]}{\text{System Clock}}$$

where DTL equals is in the range of 1 to 255.

A zero value for DTL[7:0] causes a delay-after-transfer value of  $8192 \div f_{\text{sys}}$ .

If DT is zero in a command RAM byte, a standard delay is inserted.

$$\text{Standard Delay after Transfer} = \frac{17}{f_{\text{sys}}}$$

Delay after transfer can be used to provide a peripheral deselect interval. A delay can also be inserted between consecutive transfers to allow serial A/D converters to complete conversion.

### D.6.13 QSPI Control Register 2

#### SPCR2 — QSPI Control Register 2

**\$YFFC1C**

15	14	13	12	11	10	9	8	7	6	5	4	3	2	1	0
SPIFIE	WREN	WRTO	0	ENDQP[3:0]			0	0	0	0	NEWQP[3:0]				
RESET:															
0	0	0	0	0	0	0	0	0	0	0	0	0	0	0	0

SPCR2 contains QSPI queue pointers, wraparound mode control bits, and an interrupt enable bit. The CPU32 has read/write access to SPCR2, but the QSM has read access only. SPCR2 is buffered. New SPCR2 values become effective only after completion of the current serial transfer. Rewriting NEWQP in SPCR2 causes execution to restart at the designated location. Reads of SPCR2 return the value of the register, not the buffer.

#### SPIFIE — SPI Finished Interrupt Enable

0 = QSPI interrupts disabled.

1 = QSPI interrupts enabled.

#### WREN — Wrap Enable

0 = Wraparound mode disabled.

1 = Wraparound mode enabled.

#### WRTO — Wrap To

0 = Wrap to pointer address \$0.

1 = Wrap to address in NEWQP.

#### Bit 12 — Not Implemented

ENDQP[3:0] — Ending Queue Pointer  
 This field contains the last QSPI queue address.

Bits [7:4] — Not Implemented

NEWQP[3:0] — New Queue Pointer Value  
 This field contains the first QSPI queue address.

### D.6.14 QSPI Control Register 3

**SPCR3** — QSPI Control Register

**\$YFFC1E**

15	14	13	12	11	10	9	8	7	6	5	4	3	2	1	0
0	0	0	0	0	LOOPQ	HMIE	HALT	SPSR							

RESET:

0 0 0 0 0 0 0 0

SPCR3 contains the loop mode enable bit, halt and mode fault interrupt enable, and the halt control bit. The CPU32 has read/write access to SPCR3, but the QSM has read access only. SPCR3 must be initialized before QSPI operation begins. Writing a new value to SPCR3 while the QSPI is enabled disrupts operation.

Bits [15:11] — Not Implemented

**LOOPQ** — QSPI Loop Mode

0 = Feedback path disabled.

1 = Feedback path enabled.

LOOPQ controls feedback on the data serializer for testing.

**HMIE** — HALTA and MODF Interrupt Enable

0 = HALTA and MODF interrupts disabled.

1 = HALTA and MODF interrupts enabled.

HMIE enables interrupt requests generated by the HALTA status flag or the MODF status flag in SPSR.

**HALT** — Halt QSPI

0 = QSPI operates normally.

1 = QSPI is halted for subsequent restart.

When HALT is set, the QSPI stops on a queue boundary. It remains in a defined state from which it can later be restarted.

## D.6.15 QSPI Status Register

### SPSR — QSPI Status Register

**\$YFFC1F**

15	14	13	12	11	10	9	8	7	6	5	4	3	2	1	0
SPCR3								SPIF	MODF	HALTA	0	CPTQP[3:0]			
RESET:															
								0	0	0	0	0	0	0	0

SPSR contains information concerning the current serial transmission. Only the QSPI can set bits in SPSR. The CPU32 reads SPSR to obtain QSPI status information and writes it to clear status flags.

#### SPIF — QSPI Finished Flag

0 = QSPI is not finished.

1 = QSPI is finished.

SPIF is set after execution of the command at the address in ENDQP[3:0].

#### MODF — Mode Fault Flag

0 = Normal operation.

1 = Another SPI node requested to become the network SPI master while the QSPI was enabled in master mode ( $\overline{SS}$  input taken low).

The QSPI asserts MODF when the QSPI is in master mode (MSTR = 1) and the  $\overline{SS}$  input pin is negated by an external driver.

#### HALTA — Halt Acknowledge Flag

0 = QSPI is not halted.

1 = QSPI is halted.

HALTA is set when the QSPI halts in response to setting the SPCR3 HALT bit.

#### Bit 4 — Not Implemented

#### CPTQP[3:0] — Completed Queue Pointer

CPTQP[3:0] points to the last command executed. It is updated when the current command is complete. When the first command in a queue is executing, CPTQP[3:0] contains either the reset value \$0 or a pointer to the last command completed in the previous queue.

## D.6.16 Receive Data RAM

### RR[0:F] — Receive Data RAM

**\$YFFD00 – \$YFFD0E**

Data received by the QSPI is stored in this segment. The CPU32 reads this segment to retrieve data from the QSPI. Data stored in receive RAM is right-justified. Unused bits in a receive queue entry are set to zero by the QSPI upon completion of the individual queue entry. Receive RAM data can be accessed using byte, word, or long-word addressing.

## D.6.17 Transmit Data RAM

**TR[0:F]** — Transmit Data RAM

**\$YFFD20 – \$YFFD3F**

Data that is to be transmitted by the QSPI is stored in this segment. The CPU32 normally writes one word of data into this segment for each queue command to be executed. Information to be transmitted must be written to transmit data RAM in a right-justified format. The QSPI cannot modify information in the transmit data RAM. The QSPI copies the information to its data serializer for transmission. Information remains in transmit RAM until overwritten.

## D.6.18 Command RAM

**CR[0:F]** — Command RAM

**\$YFFD40 – \$YFFD4F**

7	6	5	4	3	2	1	0
CONT	BITSE	DT	DCK	PCS3	PCS2	PCS1	PCS0 <sup>1</sup>
—	—	—	—	—	—	—	—
CONT	BITSE	DT	DCK	PCS3	PCS2	PCS1	PCS0 <sup>1</sup>
COMMAND CONTROL				PERIPHERAL CHIP SELECT			

NOTES:

1. The PCS0 bit represents the dual-function PCS0/ $\overline{SS}$ .

Command RAM is used by the QSPI when in master mode. The CPU32 writes one byte of control information to this segment for each QSPI command to be executed. The QSPI cannot modify information in command RAM.

Command RAM consists of 16 bytes. Each byte is divided into two fields. The peripheral chip-select field enables peripherals for transfer. The command control field provides transfer options.

A maximum of 16 commands can be in the queue. Queue execution proceeds from the address in NEWQP through the address in ENDQP (both of these fields are in SPCR2).

**CONT** — Continue

- 0 = Control of chip selects returned to PORTQS after transfer is complete.
- 1 = Peripheral chip selects remain asserted after transfer is complete.

**BITSE** — Bits per Transfer Enable

- 0 = Eight bits
- 1 = Number of bits set in BITS field of SPCR0.

**DT** — Delay after Transfer

- 0 = Delay after transfer is  $17 \div f_{sys}$ .
- 1 = SPCR1 DTL[7:0] specifies delay after transfer PCS valid to SCK.

**D<sub>SCK</sub> — PCS to SCK Delay**

0 = PCS valid to SCK delay is one-half SCK.

1 = SPCR1 D<sub>SCKL</sub>[6:0] specifies delay from PCS valid to SCK.

**PCS[3:0] — Peripheral Chip Select**

Use peripheral chip-select bits to select an external device for serial data transfer. More than one peripheral chip select may be activated at a time, and more than one peripheral chip can be connected to each PCS pin, provided proper fanout is observed. PCS<sub>0</sub> shares a pin with the slave select ( $\overline{SS}$ ) signal, which initiates slave mode serial transfer. If  $\overline{SS}$  is taken low when the QSPI is in master mode, a mode fault occurs.

## D.7 Configurable Timer Module 4

**Table D-35** shows the CTM4 address map. All CTM4 control registers reside in supervisor space only.

**Table D-35 CTM4 Address Map**

Address <sup>1</sup>	15	0
\$YFF400	BIUSM Module Configuration Register (BIUMCR)	
\$YFF402	BIUSM Test Register (BIUTEST)	
\$YFF404	BIUSM Time Base Register (BIUTBR)	
\$YFF406	Reserved	
\$YFF408	CPSM Control Register (CPCR)	
\$YFF40A	CPSM Test Register (CPTR)	
\$YFF40C – \$YFF40E	Reserved	
\$YFF410	MCSM2 Status/Interrupt/Control Register (MCSM2SIC)	
\$YFF412	MCSM2 Counter (MCSM2CNT)	
\$YFF414	MCSM2 Modulus Latch (MCSM2ML)	
\$YFF416	Reserved	
\$YFF418	DASM3 Status/Interrupt/Control Register (DASM3SIC)	
\$YFF41A	DASM3 Register A (DASM3A)	
\$YFF41C	DASM3 Register B (DASM3B)	
\$YFF41E	Reserved	
\$YFF420	DASM4 Status/Interrupt/Control Register (DASM4SIC)	
\$YFF422	DASM4 Register A (DASM4A)	
\$YFF424	DASM4 Register B (DASM4B)	
\$YFF426	Reserved	
\$YFF428	PWMSM5 Status/Interrupt/Control Register (PWM5SIC)	
\$YFF42A	PWMSM5 Period (PWM5A)	
\$YFF42C	PWMSM5 Pulse Width (PWM5B)	
\$YFF42E	PWMSM5 Counter (PWM5C)	
\$YFF430	PWMSM6 Status/Interrupt/Control Register (PWM6SIC)	
\$YFF432	PWMSM6 Period (PWM6A)	
\$YFF434	PWMSM6 Pulse Width (PWM6B)	
\$YFF436	PWMSM6 Counter (PWM6C)	
\$YFF438	PWMSM7 Status/Interrupt/Control Register (PWM7SIC)	
\$YFF43A	PWMSM7 Period (PWM7A)	
\$YFF43C	PWMSM7 Pulse Width (PWM7B)	
\$YFF43E	PWMSM7 Counter (PWM7C)	
\$YFF440	PWMSM8 Status/Interrupt/Control Register (PWM8SIC)	
\$YFF442	PWMSM8 Period (PWM8A)	
\$YFF444	PWMSM8 Pulse Width (PWM8B)	
\$YFF446	PWMSM8 Counter (PWM8C)	
\$YFF448	DASM9 Status/Interrupt/Control Register (DASM9SIC)	
\$YFF44A	DASM9 Register A (DASM9A)	
\$YFF44C	DASM9 Register B (DASM9B)	
\$YFF44E	Reserved	
\$YFF450	DASM10 Status/Interrupt/Control Register (DASM10SIC)	
\$YFF452	DASM10 Register A (DASM10A)	
\$YFF454	DASM10 Register B (DASM10B)	
\$YFF456	Reserved	
\$YFF458	MCSM11 Status/Interrupt/Control Register (MCSM11SIC)	



### IARB[2:0] — Interrupt Arbitration Identification ID

This bit field and the IARB3 bit within each submodule capable of requesting interrupts determine the arbitration identification numbers for each submodule requesting interrupt service.

### TBRS1, TBRS0 — Time Base Register Bus Select Bits

These bits specify which time base bus is accessed when the time base register (BIUTBR) is read. Refer to **Table D-37**.

**Table D-37 Time Base Register Bus Select Bits**

TBRS1	TBRS0	Time Base Bus
0	0	TBB1
0	1	TBB2
1	0	TBB3
1	1	TBB4

## D.7.2 BIUSM Test Configuration Register

### BIUTEST — BIUSM Test Configuration Register

**\$YFF402**

Used only during factory test.

## D.7.3 BIUSM Time Base Register

### BIUTBR — BIUSM Time Base Register

**\$YFF404**

15	14	13	12	11	10	9	8	7	6	5	4	3	2	1	0
RESET:															
0	0	0	0	0	0	0	0	0	0	0	0	0	0	0	0

BIUTBR is a read-only register used to read the value present on one of the time base buses. The time base bus accessed is determined by TBRS1 and TBRS0 in BIUMCR.

## D.7.4 CPSM Control Register

### CPCR — CPSM Control Register

**\$YFF408**

15	14	13	12	11	10	9	8	7	6	5	4	3	2	1	0
NOT USED												PRUN	DIV23	PSEL[1:0]	
RESET:															
0	0	0	0	0	0	0	0	0	0	0	0	0	0	0	0

### PRUN — Prescaler Running

The PRUN bit is a read/write control bit that turns the prescaler counter on and off. This bit allows the counters in various CTM4 submodules to be synchronized.

0 = Prescaler divider is held in reset and is not running.

1 = Prescaler is running.



### DIV23 — Divide By 2/Divide By 3

The DIV23 bit is a read/write control bit that selects the division ratio of the first prescaler stage. It may be changed at any time.

0 = First prescaler stage divides by two.

1 = First prescaler stage divides by three.

### PSEL[1:0] — Prescaler Division Ratio Select

This bit field selects the division ratio of the programmable prescaler output signal PCLK6. Refer to **Table D-38**.

**Table D-38 Prescaler Division Ratio Select Field**

Prescaler Control Bits			Prescaler Division Ratio					
DIV23	PSEL1	PSEL0	PCLK1	PCLK2	PCLK3	PCLK4	PCLK5	PCLK6
0	0	0	2	4	8	16	32	64
0	0	1	2	4	8	16	32	128
0	1	0	2	4	8	16	32	256
0	1	1	2	4	8	16	32	512
1	0	0	3	6	12	24	48	96
1	0	1	3	6	12	24	48	192
1	1	0	3	6	12	24	48	384
1	1	1	3	6	12	24	48	768

## D.7.5 CPSM Test Register

### CPTR — CPSM Test Register

**\$YFF40A**

Used only during factory test.

## D.7.6 FCSM Status/Interrupt/Control Register

### FCSMSIC — FCSM Status/Interrupt/Control Register

**\$YFF460**

15	14	13	12	11	10	9	8	7	6	5	4	3	2	1	0
COF	IL[2:0]		IARB3	NOT USED	DRVA	DRVB	IN	NOT USED			CLK[2:0]				

RESET:

U 0 0 0 0 0 0 0 U 0 0 0

### COF — Counter Overflow Flag

This flag indicates whether or not a counter overflow has occurred. An overflow is defined as the transition of the counter from \$FFFF to \$0000. If the IL[2:0] field is non-zero, an interrupt request is generated when the COF bit is set.

0 = Counter overflow has not occurred

1 = Counter overflow has occurred

This flag bit is set only by hardware and cleared by software or system reset. To clear the flag, first read the bit as a one, then write a zero to the bit.

### IL[2:0] — Interrupt Level

When the FCSM generates an interrupt request, IL[2:0] determines which of the interrupt request signals is asserted. When a request is acknowledged, the CTM4 compares IL[2:0] to a mask value supplied by the CPU32 to determine whether to respond. IL[2:0] must have a value in the range of \$0 (interrupts disabled) to \$7 (highest priority).

### IARB3 — Interrupt Arbitration Bit 3

This bit and the IARB[2:0] field in BIUMCR are concatenated to determine the interrupt arbitration number for the submodule requesting interrupt service. Refer to **D.7.1 BIU Module Configuration Register** for more information on IARB[2:0].

### DRV[A:B] — Drive Time Base Bus

This field controls the connection of the FCSM to time base buses A and B. Refer to **Table D-39**.

**Table D-39 Drive Time Base Bus Field**

DRVA	DRVB	Bus Selected
0	0	Neither time base bus A nor bus B is driven
0	1	Time base bus B is driven
1	0	Time base bus A is driven
1	1	Both time base bus A and bus B are driven

### WARNING

Two time base buses should not be driven at the same time.

### IN — Clock Input Pin Status

This read-only bit reflects the logic state of the clock input pin CTM2C. Writing to this bit has no effect nor does reset.

### CLK[2:0] — Counter Clock Select Field

These read/write control bits select one of the six CPSM clock signals (PCLK[1:6]) or one of two external conditions on CTM2C to clock the free-running counter. The maximum frequency of an external clock signal is  $f_{sys}/4$ . Refer to **Table D-40**.

**Table D-40 Counter Clock Select Field**

CLK2	CLK1	CLK0	Free Running Counter Clock Source
0	0	0	Prescaler output 1 (/2 or /3)
0	0	1	Prescaler output 2 (/4 or /6)
0	1	0	Prescaler output 3 (/8 or /12)
0	1	1	Prescaler output 4 (/16 or /24)
1	0	0	Prescaler output 5 (/32 or /48)
1	0	1	Prescaler output 6 (/64 or /512 or /96 to /768)
1	1	0	CTM2C input pin, negative edge
1	1	1	CTM2C input pin, positive edge

## D.7.7 FCSM Counter Register

**FCSMCNT** — FCSM Counter Register

**\$YFF462**

15	14	13	12	11	10	9	8	7	6	5	4	3	2	1	0
RESET:															
0	0	0	0	0	0	0	0	0	0	0	0	0	0	0	0

The FCSM counter register is a read/write register. A read returns the current value of the counter. A write loads the counter with the specified value. The counter then begins incrementing from this new value.

## D.7.8 MCSM Status/Interrupt/Control Registers

**MCSM2SIC** — MCSM2 Status/Interrupt/Control Register

**\$YFF410**

**MCSM11SIC** — MCSM11 Status/Interrupt/Control Register

**\$YFF458**

15	14	13	12	11	10	9	8	7	6	5	4	3	2	1	0
COF	IL[2:0]		IARB3	NOT USED	DRVA	DRVB	IN2	IN1	EDGEN	EDGEPE	NOT USED	CLK[2:0]			
RESET:															
U	0	0	0	0	0	0	0	U	U	0	0	0	0	0	0

### COF — Counter Overflow Flag

This bit indicates whether or not a counter overflow has occurred. An overflow of the MCSM counter is defined as the transition of the counter from \$FFFF to \$xxxx, where \$xxxx is the value contained in the modulus latch. If the IL[2:0] field is non-zero, an interrupt request is generated when the COF bit is set.

0 = Counter overflow has not occurred

1 = Counter overflow has occurred

This flag bit is set only by hardware and cleared only by software or by system reset. To clear the flag, first read the bit as a one, then write a zero to the bit.

### IL[2:0] — Interrupt Level Field

When the MCSM generates an interrupt request, IL[2:0] determines which of the interrupt request signals is asserted. When a request is acknowledged, the CTM4 compares IL[2:0] to a mask value supplied by the CPU32 to determine whether to respond. IL[2:0] must have a value in the range of \$0 (interrupts disabled) to \$7 (highest priority).

### IARB3 — Interrupt Arbitration Bit 3

This bit and the IARB[2:0] field in BIUMCR are concatenated to determine the interrupt arbitration number for the submodule requesting interrupt service. Refer to **D.7.1 BIU Module Configuration Register** for more information on IARB[2:0].

### DRV[A:B] — Drive Time Base Bus

This field controls the connection of the MCSM to time base buses A and B. Refer to **Table D-41**.

**Table D-41 Drive Time Base Bus Field**

DRVA	DRVB	Bus Selected
0	0	Neither time base bus A nor bus B is driven
0	1	Time base bus B is driven
1	0	Time base bus A is driven
1	1	Both time base bus A and bus B are driven

**WARNING**

Two time base buses should not be driven at the same time.

**IN2 — Clock Input Pin Status**

This read-only bit reflects the logic state of the clock input pin CTM2C. Writing to this bit has no effect nor does reset.

**IN1 — Modulus Load Input Pin Status**

This read-only bit reflects the logic state of the modulus load input pin CTD9. Writing to this bit has no effect nor does reset.

**EDGEN, EDGE P — Modulus Load Edge Sensitivity Bits**

These read/write control bits select which edge on CTD9 triggers the modulus load input. Refer to **Table D-42**.

**Table D-42 Modulus Load Edge Sensitivity Bits**

EDGEN	EDGE P	IN1 Edge Detector Sensitivity
0	0	None
0	1	Positive edge only
1	0	Negative edge only
1	1	Positive and negative edge

**CLK[2:0] — Counter Clock Select Field**

These read/write control bits select one of the six CPSM clock signals (PCLK[1:6]) or one of two external conditions on CTM2C to clock the modulus counter. The maximum frequency of an external clock signal is  $f_{\text{sys}}/4$ . Refer to **Table D-43**.

**Table D-43 Counter Clock Select Field**

CLK2	CLK1	CLK0	Free Running Counter Clock Source
0	0	0	Prescaler output 1 (/2 or /3)
0	0	1	Prescaler output 2 (/4 or /6)
0	1	0	Prescaler output 3 (/8 or /12)
0	1	1	Prescaler output 4 (/16 or /24)
1	0	0	Prescaler output 5 (/32 or /48)
1	0	1	Prescaler output 6 (/64 to /768)
1	1	0	CTM2C input pin, negative edge
1	1	1	CTM2C input pin, positive edge

## D.7.9 MCSM Counter Registers

**MCSM2CNT** — MCSM2 Counter Register **\$YFF412**

**MCSM11CNT** — MCSM11 Counter Register **\$YFF45A**

15	14	13	12	11	10	9	8	7	6	5	4	3	2	1	0

RESET:

0   0   0   0   0   0   0   0   0   0   0   0   0   0   0   0

The MCSM counter register is a read/write register. A read returns the current value of the counter. A write simultaneously loads both the counter and the MCSM modulus latch with the specified value. The counter then begins incrementing from this new value.

## D.7.10 MCSM Modulus Latch Registers

**MCSM2ML** — MCSM2 Modulus Latch **\$YFF414**

**MCSM11ML** — MCSM11 Modulus Latch **\$YFF45C**

15	14	13	12	11	10	9	8	7	6	5	4	3	2	1	0

RESET:

0   0   0   0   0   0   0   0   0   0   0   0   0   0   0   0

The MCSM modulus latch register is a read/write register. A read returns the current value of the latch. A write pre-loads the latch with a new value that the modulus counter will begin counting from when the next load condition occurs.

## D.7.11 DASM Status/Interrupt/Control Registers

**DASM3SIC** — DASM3 Status/Interrupt/Control Register **\$YFF418**

**DASM4SIC** — DASM4 Status/Interrupt/Control Register **\$YFF420**

**DASM9SIC** — DASM9 Status/Interrupt/Control Register **\$YFF448**

**DASM10SIC** — DASM10 Status/Interrupt/Control Register **\$YFF450**

15	14	13	12	11	10	9	8	7	6	5	4	3	2	1	0
FLAG	IL[2:0]		IARB3	NOT USED	WOR	BSL	IN	FORCA	FORCB	EDPOL	MODE[3:0]				

RESET:

0   0   0   0   0   0   0   0   U   0   0   0   0   0   0   0

### FLAG — Event Flag

This status bit indicates whether or not an input capture or output compare event has occurred. If the IL[2:0] field is non-zero, an interrupt request is generated when the FLAG bit is set.

0 = An input capture or output compare event has not occurred

1 = An input capture or output compare event has occurred

**Table D-44** shows the status of the FLAG bit in different DASM operating modes.

**Table D-44 DASM Mode Flag Status Bit States**

Mode	Flag Status Bit State
DIS	FLAG bit is reset
IPWM	FLAG bit is set each time there is a capture on channel A
IPM	FLAG bit is set each time there is a capture on channel A, except for the first time
IC	FLAG bit is set each time there is a capture on channel A
OCB	FLAG bit is set each time there is a successful comparison on channel B
OCAB	FLAG bit is set each time there is a successful comparison on either channel A or B
OPWM	FLAG bit is set each time there is a successful comparison on channel A

The FLAG bit is set by hardware and cleared by software, or by system reset. Clear the FLAG bit either by writing a zero to it, having first read the bit as a one, or by selecting the DIS mode.

#### IL[2:0] — Interrupt Level

When the DASM generates an interrupt request, IL[2:0] determines which of the interrupt request signals is asserted. When a request is acknowledged, the CTM4 compares IL[2:0] to a mask value supplied by the CPU32 to determine whether to respond. IL[2:0] must have a value in the range of \$0 (interrupts disabled) to \$7 (highest priority).

#### IARB3 — Interrupt Arbitration Bit 3

This bit and the IARB[2:0] field in BIUMCR are concatenated to determine the interrupt arbitration number for the submodule requesting interrupt service. Refer to **D.7.1 BIU Module Configuration Register** for more information on IARB[2:0].

#### WOR — Wired-OR Mode

In the DIS, IPWM, IPM and IC modes, the WOR bit is not used. Reading this bit returns the value that was previously written.

In the OCB, OCAB and OPWM modes, the WOR bit selects whether the output buffer is configured for open-drain or normal operation.

0 = Output buffer operates in normal mode.

1 = Output buffer operates in open-drain mode.

#### BSL — Bus Select

This bit selects the time base bus connected to the DASM.

0 = DASM is connected to time base bus A.

1 = DASM is connected to time base bus B.

#### IN — Input Pin Status

In the DIS, IPWM, IPM and IC modes, this read-only status bit reflects the logic level on the input pin.

In the OCB, OCAB and OPWM modes, reading this bit returns the value latched on the output flip-flop, after EDPOL polarity selection.

Writing to this bit has no effect.

### FORCA — Force A

In the OCB, OCAB and OPWM modes, FORCA bit allows software to force the output flip-flop to behave as if a successful comparison had occurred on channel A (except that the FLAG bit is not set). Writing a one to FORCA sets the output flip-flop; writing a zero has no effect.

In the DIS, IPWM, IPM and IC modes, the FORCA bit is not used and writing to it has no effect.

FORCA is cleared by reset, and always reads as zero.

#### NOTE

Writing a one to both FORCA and FORCB simultaneously resets the output flip-flop.

### FORCB — Force B

In the OCB, OCAB and OPWM modes, FORCB allows software to force the output flip-flop to behave as if a successful comparison had occurred on channel B (except that the FLAG bit is not set). Writing a one to FORCB sets the output flip-flop, writing a zero has no effect.

In the DIS, IPWM, IPM and IC modes, the FORCB bit is not used and writing to it has no effect.

FORCB is cleared by reset, and always reads as zero.

#### NOTE

Writing a one to both FORCA and FORCB simultaneously resets the output flip-flop.

### EDPOL — Edge Polarity Bit

EDPOL selects different options depending on the DASM operating mode. Refer to **Table D-45**.

**Table D-45 Edge Polarity**

MODE	EDPOL	Function
DIS	X	EDPOL is not used in DIS mode
IPWM	0	Channel A captures on a rising edge Channel B captures on a falling edge
	1	Channel A captures on a falling edge Channel B captures on a rising edge
IPM, IC	0	Channel A captures on a rising edge
	1	Channel A captures on a falling edge
OCB, OCAB, OPWM	0	A compare on channel A sets the output pin to logic 1 A compare on channel B clears the output pin to logic 0
	1	A compare on channel A clears the output pin to logic 0 A compare on channel B sets the output pin to logic 1

MODE[3:0] — DASM Mode Select

This bit field selects the mode of operation of the DASM. Refer to **Table D-46**.

**NOTE**

To avoid spurious interrupts, DASM interrupts should be disabled before changing the operating mode.

**Table D-46 DASM Mode Select Field**

MODE[3:0]	Bits of Resolution	Time Base Bits Ignored	DASM Operating Mode
0000	—	—	DIS – Disabled
0001	16	—	IPWM – Input pulse width measurement
0010	16	—	IPM – Input measurement period
0011	16	—	IC – Input capture
0100	16	—	OCB – Output compare, flag on B compare
0101	16	—	OCAB – Output compare, flag on A and B compare
011X	—	—	Not used
1000	16	—	OPWM – Output pulse width modulation
1001	15	15	OPWM – Output pulse width modulation
1010	14	[15:14]	OPWM – Output pulse width modulation
1011	13	[15:13]	OPWM – Output pulse width modulation
1100	12	[15:12]	OPWM – Output pulse width modulation
1101	11	[15:11]	OPWM – Output pulse width modulation
1110	9	[15:9]	OPWM – Output pulse width modulation
1111	7	[15:7]	OPWM – Output pulse width modulation

**D.7.12 DASM Data Register A**

**DASM3A** — DASM3 Data Register A **\$YFF41A**  
**DASM4A** — DASM4 Data Register A **\$YFF422**  
**DASM9A** — DASM9 Data Register A **\$YFF44A**  
**DASM10A** — DASM10 Data Register A **\$YFF452**

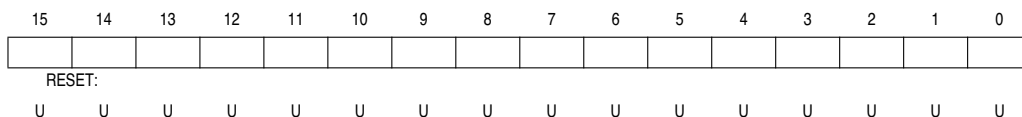

DASMA is the data register associated with channel A. **Table D-47** shows how DASMA is used with the different modes of operation.

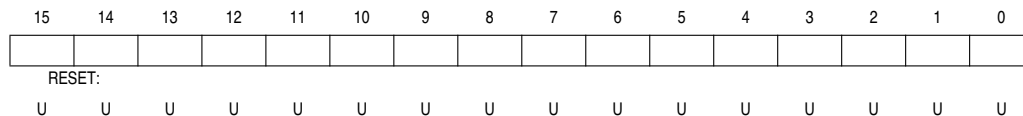

**Table D-47 DASMA Operations**

Mode	DASMA Operation
DIS	DASMA can be accessed to prepare a value for a subsequent mode selection
IPWM	DASMA contains the captured value corresponding to the trailing edge of the measured pulse
IPM	DASMA contains the captured value corresponding to the most recently detected user-specified rising or falling edge
IC	DASMA contains the captured value corresponding to the most recently detected user-specified rising or falling edge
OCB	DASMA is loaded with the value corresponding to the leading edge of the pulse to be generated. Writing to DASMA in the OCB and OCAB modes also enables the corresponding channel A comparator until the next successful comparison.
OCAB	DASMA is loaded with the value corresponding to the leading edge of the pulse to be generated. Writing to DASMA in the OCB and OCAB modes also enables the corresponding channel A comparator until the next successful comparison.
OPWM	DASMA is loaded with the value corresponding to the leading edge of the PWM pulse to be generated.

**D.7.13 DASM Data Register B**

- DASM3B** — DASM3 Data Register B **\$YFF41C**
- DASM4B** — DASM4 Data Register B **\$YFF424**
- DASM9B** — DASM9 Data Register B **\$YFF44C**
- DASM10B** — DASM10 Data Register B **\$YFF454**



DASMB is the data register associated with channel B. **Table D-48** shows how DASMB is used with the different modes of operation. Depending on the mode selected, software access is to register B1 or register B2.

**Table D-48 DASMB Operations**

Mode	DASMB Operation
DIS	DASMB can be accessed to prepare a value for a subsequent mode selection. In this mode, register B1 is accessed in order to prepare a value for the OPWM mode. Unused register B2 is hidden and cannot be read, but is written with the same value as register B1 is written.
IPWM	DASMB contains the captured value corresponding to the trailing edge of the measured pulse. In this mode, register B2 is accessed. Buffer register B1 is hidden and cannot be accessed.
IPM	DASMB contains the captured value corresponding to the most recently detected user-specified rising or falling edge. In this mode, register B2 is accessed. Buffer register B1 is hidden and cannot be accessed.
IC	DASMB contains the captured value corresponding to the most recently detected user-specified rising or falling edge. In this mode, register B2 is accessed. Buffer register B1 is hidden and cannot be accessed.
OCB	DASMB is loaded with the value corresponding to the trailing edge of the pulse to be generated. Writing to DASMB in the OCB and OCAB modes also enables the corresponding channel B comparator until the next successful comparison. In this mode, register B2 is accessed. Buffer register B1 is hidden and cannot be accessed.
OCAB	DASMB is loaded with the value corresponding to the trailing edge of the pulse to be generated. Writing to DASMB in the OCB and OCAB modes also enables the corresponding channel B comparator until the next successful comparison. In this mode, register B2 is accessed. Buffer register B1 is hidden and cannot be accessed.
OPWM	DASMB is loaded with the value corresponding to the trailing edge of the PWM pulse to be generated. In this mode, register B1 is accessed. Buffer register B2 is hidden and cannot be accessed.

**D.7.14 PWM Status/Interrupt/Control Register**

**PWM5SIC** — PWM5 Status/Interrupt/Control Register **\$YFF428**  
**PWM6SIC** — PWM6 Status/Interrupt/Control Register **\$YFF430**  
**PWM7SIC** — PWM7 Status/Interrupt/Control Register **\$YFF438**  
**PWM8SIC** — PWM8 Status/Interrupt/Control Register **\$YFF440**

15	14	13	12	11	10	9	8	7	6	5	4	3	2	1	0
FLAG	IL[2:0]			IARB3	NOT USED			PIN	NOT USED	LOAD	POL	EN	CLK[2:0]		

RESET:

0 0 0 0 0 0 0 0 0 0 0 0 0 0 0 0

**FLAG — Period Completion Status**

This status bit indicates when the PWM output period has been completed.

0 = PWM period is not complete.

1 = PWM period is complete.

The FLAG bit is set each time a PWM period is completed. Whenever the PWM is enabled, the FLAG bit is set immediately to indicate that the contents of the buffer registers PWMA2 and PWMB2 have been updated, and that the period using these new values has started. It also indicates that the user accessible period and pulse width registers PWMA1 and PWMB1 can be loaded with values for the next PWM period. Once set, the FLAG bit remains set and is not affected by any subsequent period completions, until it is cleared.

Only software can clear the FLAG bit. To clear FLAG, first read the bit as one then write a zero to the bit. Writing a one to FLAG has no effect. When the PWM is disabled, FLAG remains cleared.

When the interrupt level set specified by IL[2:0] is non-zero, an interrupt request is generated when the FLAG bit is set.

#### IL[2:0] — Interrupt Level Field

When the PWMSM generates an interrupt request, IL[2:0] determines which of the interrupt request signals is asserted. When a request is acknowledged, the CTM4 compares IL[2:0] to a mask value supplied by the CPU32 to determine whether to respond. IL[2:0] must have a value in the range of \$0 (interrupts disabled) to \$7 (highest priority).

#### IARB3 — Interrupt Arbitration Bit 3

This bit and the IARB[2:0] field in BIUMCR are concatenated to determine the interrupt arbitration number for the submodule requesting interrupt service. Refer to **D.7.1 BIU Module Configuration Register** for more information on IARB[2:0].

#### PIN — Output Pin Status

This status bit indicates the logic state present on the PWM output pin.

0 = Logic zero present on the PWM output pin.

1 = Logic one present on the PWM output pin.

PIN is a read-only bit; writing to it has no effect.

#### LOAD — Period and Pulse Width Register Load Control

Setting LOAD reinitializes the PWMSM and starts a new PWM period without causing a glitch on the output signal.

0 = No action

1 = Load period and pulse width registers

This bit is always read as a zero. Writing a one to this bit results in the following immediate actions:

- The contents of PWMA1 (period value) are transferred to PWMA2.
- The contents of PWMB1 (pulse width value) are transferred to PWMB2.
- The counter register (PWMC) is initialized to \$0001.
- The control logic and state sequencer are reset.
- The FLAG bit is set.
- The output flip-flop is set if the new value in PWMB2 is not \$0000.

#### NOTE

Writing a one to the LOAD bit when the EN bit = 0, (when the PWMSM is disabled), has no effect.

#### POL — Output Pin Polarity Control

This control bit sets the polarity of the PWM output signal. It works in conjunction with the EN bit and controls whether the PWMSM drives the output pin with the non-inverted or inverted state of the output flip-flop. Refer to **Table D-49**.

**Table D-49 PWMSM Output Pin Polarity Selection**

POL	EN	Output Pin State	Periodic Edge	Variable Edge	Optional Interrupt On
0	0	Always low	—	—	—
1	0	Always high	—	—	—
0	1	High pulse	Rising edge	Falling edge	Rising edge
1	1	Low pulse	Falling edge	Rising edge	Falling edge

**EN — PWMSM Enable**

This control bit enables and disables the PWMSM.

0 = Disable the PWMSM.

1 = Enable the PWMSM.

While the PWMSM is disabled (EN = 0):

- The output flip-flop is held in reset and the level on the output pin is set to one or zero according to the state of the POL bit.
- The PWMSM divide-by-256 prescaler is held in reset.
- The counter stops incrementing and is at \$0001.
- The comparators are disabled.
- The PWMA1 and PWMB1 registers permanently transfer their contents to the buffer registers PWMA2 and PWMB2, respectively.

When the EN bit is changed from zero to one:

- The output flip-flop is set to start the first pulse.
- The PWMSM divide-by-256 prescaler is released.
- The counter is released and starts to increment from \$0001.
- The FLAG bit is set to indicate that PWMA1 and PWMB1 can be updated with new values.

While EN is set, the PWMSM continuously generates a pulse width modulated output signal based on the data in PWMA2 and PWMB2 which are updated via PWMA1 and PWMB2 each time a period is completed.

**NOTE**

To prevent unwanted output waveform glitches when disabling the PWMSM, first write to PWMB1 to generate one period of 0% duty cycle, then clear EN.

**CLK[2:0] — Clock Rate Selection**

The CLK[2:0] bits select one of the eight counter clock sources coming from the PWMSM prescaler. These bits can be changed at any time. **Table D-50** shows the counter clock sources and rates in detail.

**Table D-50 PWMSM Divide By Options**

CLK2	CLK1	CLK0	PCLK1 = $f_{sys} \div 2$ (CPCR DIV23 = 0)	PCLK1 = $f_{sys} \div 2$ (CPCR DIV23 = 0)
0	0	0	$f_{sys} \div 2$	$f_{sys} \div 3$
0	0	1	$f_{sys} \div 4$	$f_{sys} \div 6$
0	1	0	$f_{sys} \div 8$	$f_{sys} \div 12$
0	1	1	$f_{sys} \div 16$	$f_{sys} \div 24$
1	0	0	$f_{sys} \div 32$	$f_{sys} \div 48$
1	0	1	$f_{sys} \div 64$	$f_{sys} \div 96$
1	1	0	$f_{sys} \div 128$	$f_{sys} \div 192$
1	1	1	$f_{sys} \div 512$	$f_{sys} \div 768$

**D.7.15 PWM Period Register**

- PWM5A1** — PWM5A Period Register **\$YFF42A**
- PWM6A1** — PWM6A Period Register **\$YFF432**
- PWM7A1** — PWM7A Period Register **\$YFF43A**
- PWM8A1** — PWM8A Period Register **\$YFF442**

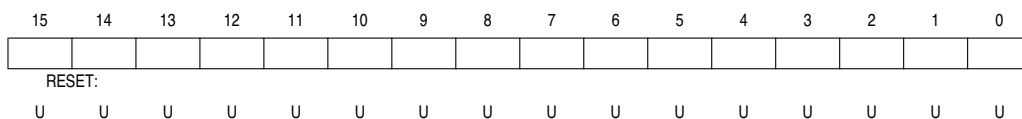

The PWMA1 register contains the period value for the next cycle of the PWM output waveform. When the PWMSM is enabled, a period value written to PWMA1 is loaded into PWMA2 at the end of the current period or when the LOAD bit in PWMSIC is written to one. If the PWMSM is disabled, a period value written to PWMA1 is loaded into PWMA2 on the next half cycle of the MCU system clock. PWMA2 is a temporary register that is used to smoothly update the PWM period value; it is not user-accessible. The PWMSM hardware does not modify the contents of PWMA1 at any time.

**D.7.16 PWM Pulse Width Register**

- PWM5B1** — PWM5 Pulse Width Register **\$YFF42C**
- PWM6B1** — PWM6 Pulse Width Register **\$YFF43A**
- PWM7B1** — PWM7 Pulse Width Register **\$YFF43C**
- PWM8B1** — PWM8 Pulse Width Register **\$YFF44A**

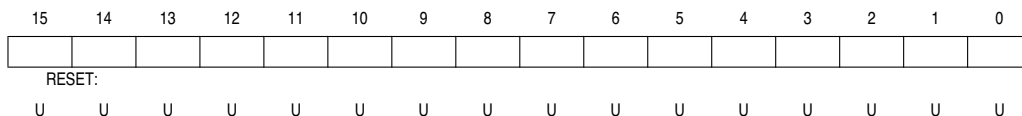

The PWMB1 register contains the pulse width value for the next cycle of the PWM output waveform. When the PWMSM is enabled, a pulse width value written to PWMB1 is loaded into PWMB2 at the end of the current period or when the LOAD bit in PWM-SIC is written to one. If the PWMSM is disabled, a pulse width value written to PWMB1 is loaded into PWMB2 on the next half cycle of the MCU system clock. PWMB2 is a temporary register that is used to smoothly update the PWM pulse width value; it is not user-accessible. The PWMSM hardware does not modify the contents of PWMB1 at any time.

### D.7.17 PWM Counter Register

<b>PWM5C</b>	— PWM5 Counter Register	<b>\$YFF42E</b>
<b>PWM6C</b>	— PWM6 Counter Register	<b>\$YFF436</b>
<b>PWM7C</b>	— PWM7 Counter Register	<b>\$YFF43E</b>
<b>PWM8C</b>	— PWM8 Counter Register	<b>\$YFF446</b>

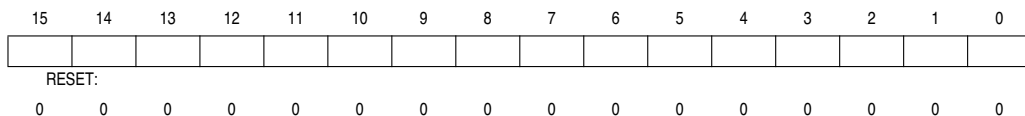

PWMC holds the current value of the PWMSM counter. PWMC can be read at any time; writing to it has no effect. PWMC is loaded with \$0001 on reset and is set and held to that value whenever the PWMSM is disabled.

## D.8 Time Processor Unit (TPU)

**Table D-51** shows the TPU address map. The column labeled “Access” indicates the privilege level at which the CPU32 must be operating to access the register. A designation of “S” indicates that supervisor mode is required. A designation of “S/U” indicates that the register can be programmed for either supervisor mode access or unrestricted access.

**Table D-51 TPU Register Map**

Access	Address <sup>1</sup>	15	0
S	\$YFFE00	Module Configuration Register (TPUMCR)	
S	\$YFFE02	Test Configuration Register (TCR)	
S	\$YFFE04	Development Support Control Register (DSCR)	
S	\$YFFE06	Development Support Status Register (DSSR)	
S	\$YFFE08	TPU Interrupt Configuration Register (TICR)	
S	\$YFFE0A	Channel Interrupt Enable Register (CIER)	
S	\$YFFE0C	Channel Function Selection Register 0 (CFSR0)	
S	\$YFFE0E	Channel Function Selection Register 1 (CFSR1)	
S	\$YFFE10	Channel Function Selection Register 2 (CFSR2)	
S	\$YFFE12	Channel Function Selection Register 3 (CFSR3)	
S/U	\$YFFE14	Host Sequence Register 0 (HSQR0)	
S/U	\$YFFE16	Host Sequence Register 1 (HSQR1)	
S/U	\$YFFE18	Host Service Request Register 0 (HSRR0)	
S/U	\$YFFE1A	Host Service Request Register 1 (HSRR1)	
S	\$YFFE1C	Channel Priority Register 0 (CPR0)	
S	\$YFFE1E	Channel Priority Register 1 (CPR1)	
S	\$YFFE20	Channel Interrupt Status Register (CISR)	
S	\$YFFE22	Link Register (LR)	
S	\$YFFE24	Service Grant Latch Register (SGLR)	
S	\$YFFE26	Decoded Channel Number Register (DCNR)	

**NOTES:**

1. Y = M111, where M represents the logic state of the module mapping (MM) bit in the SIMCR.

### D.8.1 TPU Module Configuration Register

#### TPUMCR — TPU Module Configuration Register

**\$YFFE00**

15	14	13	12	11	10	9	8	7	6	5	4	3	2	1	0
STOP	TCR1P[1:0]		TCR2P[1:0]		EMU	T2CG	STF	SUPV	PSCK	0	0	IARB[3:0]			

**RESET:**

0 0 0 0 0 0 0 0 1 0 0 0 0 0 0 0

#### STOP — Low-Power Stop Mode Enable

0 = Enable TPU clocks.

1 = Disable TPU clocks.

### TCR1P[1:0] — Timer Count Register 1 Prescaler Control

TCR1 is clocked from the output of a prescaler. The prescaler's input is the internal TPU system clock divided by either 4 or 32, depending on the value of the PSCK bit. The prescaler divides this input by 1, 2, 4, or 8. Channels using TCR1 have the capability to resolve down to the TPU system clock divided by four. **Table D-52** is a summary of prescaler output.

**Table D-52 TCR1 Prescaler Control Bits**

TCR1P[1:0]	Prescaler Divide By	TCR1 Clock Input	
		PSCK = 0	PSCK = 1
00	1	$f_{\text{sys}} \div 32$	$f_{\text{sys}} \div 4$
01	2	$f_{\text{sys}} \div 64$	$f_{\text{sys}} \div 8$
10	4	$f_{\text{sys}} \div 128$	$f_{\text{sys}} \div 16$
11	8	$f_{\text{sys}} \div 256$	$f_{\text{sys}} \div 32$

### TCR2P[1:0] — Timer Count Register 2 Prescaler Control

TCR2 is clocked from the output of a prescaler. If T2CG = 0, the input to the TCR2 prescaler is the external TCR2 clock source. If T2CG = 1, the input is the TPU system clock divided by eight. The TCR2P field specifies the value of the prescaler: 1, 2, 4, or 8. Channels using TCR2 have the capability to resolve down to the TPU system clock divided by eight. **Table D-53** is a summary of prescaler output.

**Table D-53 TCR2 Prescaler Control Bits**

TCR2P[1:0]	Prescaler Divide By	Internal Clock Divided By	External Clock Divided By
00	1	8	1
01	2	16	2
10	4	32	4
11	8	64	8

### EMU — Emulation Control

In emulation mode, the TPU executes microinstructions from TPURAM exclusively. Access to the TPURAM module via the IMB is blocked, and the TPURAM module is dedicated for use by the TPU. After reset, this bit can be written only once.

0 = TPU and TPURAM operate normally.

1 = TPU and TPURAM operate in emulation mode.

### T2CG — TCR2 Clock/Gate Control

When T2CG is set, the external TCR2 pin functions as a gate of the DIV8 clock (the TPU system clock divided by eight). In this case, when the external TCR2 pin is low, the DIV8 clock is blocked, preventing it from incrementing TCR2. When the external TCR2 pin is high, TCR2 is incremented at the frequency of the DIV8 clock. When T2CG is cleared, an external clock input from the TCR2 pin, which has been synchronized and fed through a digital filter, increments TCR2.

0 = TCR2 pin used as clock source for TCR2.

1 = TCR2 pin used as gate of DIV8 clock for TCR2.



STF — Stop Flag  
 0 = TPU is operating.  
 1 = TPU is stopped (STOP bit has been set).

SUPV — Supervisor/Unrestricted  
 0 = Assignable registers are accessible in user or supervisor mode.  
 1 = Assignable registers are accessible in supervisor mode only.

PSCK — Prescaler Clock  
 0 =  $f_{sys} \div 32$  is input to TCR1 prescaler.  
 1 =  $f_{sys} \div 4$  is input to TCR1 prescaler.

IARB[3:0] — Interrupt Arbitration ID  
 The IARB field is used to arbitrate between simultaneous interrupt requests of the same priority. Each module that can generate interrupt requests must be assigned a unique, non-zero IARB field value.

### D.8.2 Test Configuration Register

TCR — Test Configuration Register \$YFFE02  
 Used for factory test only.

### D.8.3 Development Support Control Register

DSCR — Development Support Control Register \$YFFE04

15	14	13	12	11	10	9	8	7	6	5	4	3	2	1	0
HOT4	NOT USED				BLC	CLKS	FRZ[1:0]		CCL	BP	BC	BH	BL	BM	BT
RESET:															
0					0	0	0	0	0	0	0	0	0	0	0

HOT4 — Hang on T4  
 0 = Exit wait on T4 state caused by assertion of HOT4.  
 1 = Enter wait on T4 state.

BLC — Branch Latch Control  
 0 = Latch conditions into branch condition register before exiting halted state.  
 1 = Do not latch conditions into branch condition register before exiting the halted state or during the time-slot transition period.

CLKS — Stop Clocks (to TCRs)  
 0 = Do not stop TCRs.  
 1 = Stop TCRs during the halted state.

FRZ[1:0] — FREEZE Assertion Response  
 The FRZ bits specify the TPU microengine response to the IMB FREEZE signal. Refer to **Table D-54**.

**Table D-54 FRZ[1:0] Encoding**

FRZ[1:0]	TPU Response
00	Ignore freeze
01	Reserved
10	Freeze at end of current microcycle
11	Freeze at next time-slot boundary

**CCL — Channel Conditions Latch**

CCL controls the latching of channel conditions (MRL and TDL) when the CHAN register is written.

0 = Only the pin state condition of the new channel is latched as a result of the write CHAN register microinstruction.

1 = Pin state, MRL, and TDL conditions of the new channel are latched as a result of a write CHAN register microinstruction.

**BP, BC, BH, BL, BM, and BT — Breakpoint Enable Bits**

These bits are TPU breakpoint enables. Setting a bit enables a breakpoint condition.

**Table D-55** shows the different breakpoint enable bits.

**Table D-55 Breakpoint Enable Bits**

Enable Bit	Function
BP	Break if $\mu$ PC equals $\mu$ PC breakpoint register
BC	Break if CHAN register equals channel breakpoint register at beginning of state or when CHAN is changed through microcode
BH	Break if host service latch is asserted at beginning of state
BL	Break if link service latch is asserted at beginning of state
BM	Break if MRL is asserted at beginning of state
BT	Break if TDL is asserted at beginning of state

**D.8.4 Development Support Status Register**

**DSSR — Development Support Status Register**

**\$YFFE06**

15	14	13	12	11	10	9	8	7	6	5	4	3	2	1	0
0	0	0	0	0	0	0	0	BKPT	PCBK	CHBK	SRBK	TPUF	0	0	0

RESET:

0	0	0	0	0	0	0	0	0	0	0	0	0	0	0	0
---	---	---	---	---	---	---	---	---	---	---	---	---	---	---	---

**BKPT — Breakpoint Asserted Flag**

If an internal breakpoint caused the TPU to enter the halted state, the TPU asserts the BKPT signal on the IMB and sets the BKPT flag. BKPT remains set until the TPU recognizes a breakpoint acknowledge cycle, or until the IMB FREEZE signal is asserted.

**PCBK —  $\mu$ PC Breakpoint Flag**

PCBK is asserted if a breakpoint occurs because of a  $\mu$ PC (microprogram counter) register match with the  $\mu$ PC breakpoint register. PCBK is negated when the BKPT flag is cleared.

### CHBK — Channel Register Breakpoint Flag

CHBK is asserted if a breakpoint occurs because of a CHAN register match with the CHAN register breakpoint register. CHBK is negated when the BKPT flag is cleared.

### SRBK — Service Request Breakpoint Flag

SRBK is asserted if a breakpoint occurs because of any of the service request latches being asserted along with their corresponding enable flag in the development support control register. SRBK is negated when the BKPT flag is cleared.

### TPUF — TPU FREEZE Flag

TPUF is set whenever the TPU is in a halted state as a result of FREEZE being asserted. This flag is automatically negated when the TPU exits the halted state because of FREEZE being negated.

## D.8.5 TPU Interrupt Configuration Register

### TICR — TPU Interrupt Configuration Register

**\$YFFE08**

15	10	9	8	7	6	5	4	3	0
NOT USED			CIRL[2:0]		CIBV[3:0]			NOT USED	
RESET:									
0			0		0			0	

### CIRL[2:0] — Channel Interrupt Request Level

This three-bit field specifies the interrupt request level for all channels. Level seven for this field indicates a non-maskable interrupt; level zero indicates that all channel interrupts are disabled.

### CIBV[3:0] — Channel Interrupt Base Vector

The TPU is assigned 16 unique interrupt vector numbers, one vector number for each channel. The CIBV field specifies the most significant nibble of all 16 TPU channel interrupt vector numbers. The lower nibble of the TPU interrupt vector number is determined by the channel number on which the interrupt occurs.

## D.8.6 Channel Interrupt Enable Register

### CIER — Channel Interrupt Enable Register

**\$YFFE0A**

15	14	13	12	11	10	9	8	7	6	5	4	3	2	1	0
CH 15	CH 14	CH 13	CH 12	CH 11	CH 10	CH 9	CH 8	CH 7	CH 6	CH 5	CH 4	CH 3	CH 2	CH 1	CH 0
RESET:															
0															

### CH[15:0] — Channel Interrupt Enable/Disable

0 = Channel interrupts disabled

1 = Channel interrupts enabled

## D.8.7 Channel Function Select Registers

### CFSR0 — Channel Function Select Register 0 \$YFFE0C

15	14	13	12	11	10	9	8	7	6	5	4	3	2	1	0
CHANNEL 15				CHANNEL 14				CHANNEL 13				CHANNEL 12			
RESET:															
0	0	0	0	0	0	0	0	0	0	0	0	0	0	0	0

### CFSR1 — Channel Function Select Register 1 \$YFFE0E

15	14	13	12	11	10	9	8	7	6	5	4	3	2	1	0
CHANNEL 11				CHANNEL 10				CHANNEL 9				CHANNEL 8			
RESET:															
0	0	0	0	0	0	0	0	0	0	0	0	0	0	0	0

### CFSR2 — Channel Function Select Register 2 \$YFFE10

15	14	13	12	11	10	9	8	7	6	5	4	3	2	1	0
CHANNEL 7				CHANNEL 6				CHANNEL 5				CHANNEL 4			
RESET:															
0	0	0	0	0	0	0	0	0	0	0	0	0	0	0	0

### CFSR3 — Channel Function Select Register 3 \$YFFE12

15	14	13	12	11	10	9	8	7	6	5	4	3	2	1	0
CHANNEL 3				CHANNEL 2				CHANNEL 1				CHANNEL 0			
RESET:															
0	0	0	0	0	0	0	0	0	0	0	0	0	0	0	0

### CHANNEL[15:0] — Encoded Time Function for each Channel

Encoded four-bit fields in the channel function select registers specify one of 16 time functions to be executed on the corresponding channel.

## D.8.8 Host Sequence Registers

### HSQR0 — Host Sequence Register 0 \$YFFE14

15	14	13	12	11	10	9	8	7	6	5	4	3	2	1	0
CH 15	CH 14	CH 13	CH 12	CH 11	CH 10	CH 9	CH 8	CH 7	CH 6	CH 5	CH 4	CH 3	CH 2	CH 1	CH 0
RESET:															
0	0	0	0	0	0	0	0	0	0	0	0	0	0	0	0

### HSQR1 — Host Sequence Register 1 \$YFFE16

15	14	13	12	11	10	9	8	7	6	5	4	3	2	1	0
CH 7	CH 6	CH 5	CH 4	CH 3	CH 2	CH 1	CH 0	CH 7	CH 6	CH 5	CH 4	CH 3	CH 2	CH 1	CH 0
RESET:															
0	0	0	0	0	0	0	0	0	0	0	0	0	0	0	0

### CH[15:0] — Encoded Host Sequence

The host sequence field selects the mode of operation for the time function selected on a given channel. The meaning of the host sequence bits depends on the time function specified.

## D.8.9 Host Service Request Registers

### HSSR0 — Host Service Request Register 0

**\$YFFE18**

15	14	13	12	11	10	9	8	7	6	5	4	3	2	1	0
CH 15	CH 14	CH 13	CH 12	CH 11	CH 10	CH 9	CH 8								
RESET:															
0	0	0	0	0	0	0	0	0	0	0	0	0	0	0	0

### HSSR1 — Host Service Request Register 1

**\$YFFE1A**

15	14	13	12	11	10	9	8	7	6	5	4	3	2	1	0
CH 7	CH 6	CH 5	CH 4	CH 3	CH 2	CH 1	CH 0								
RESET:															
0	0	0	0	0	0	0	0	0	0	0	0	0	0	0	0

### CH[15:0] — Encoded Type of Host Service

The host service request field selects the type of host service request for the time function selected on a given channel. The meaning of the host service request bits depends on the time function specified.

A host service request field cleared to %00 signals the host that service is completed by the microengine on that channel. The host can request service on a channel by writing the corresponding host service request field to one of three non-zero states. The CPU32 should monitor the host service request register until the TPU clears the service request to %00 before any parameters are changed or a new service request is issued to the channel.

## D.8.10 Channel Priority Registers

### CPR0 — Channel Priority Register 0

**\$YFFE1C**

15	14	13	12	11	10	9	8	7	6	5	4	3	2	1	0
CH 15	CH 14	CH 13	CH 12	CH 11	CH 10	CH 9	CH 8								
RESET:															
0	0	0	0	0	0	0	0	0	0	0	0	0	0	0	0

### CPR1 — Channel Priority Register 1

**\$YFFE1E**

15	14	13	12	11	10	9	8	7	6	5	4	3	2	1	0
CH 7	CH 6	CH 5	CH 4	CH 3	CH 2	CH 1	CH 0								
RESET:															
0	0	0	0	0	0	0	0	0	0	0	0	0	0	0	0

CH[15:0] — Encoded Channel Priority Levels

Table D-56 shows channel priority levels.

**Table D-56 Channel Priorities**

CHx[1:0]	Service	Guaranteed Time Slots
00	Disabled	—
01	Low	1 out of 7
10	Middle	2 out of 7
11	High	4 out of 7

### D.8.11 Channel Interrupt Status Register

**CISR** — Channel Interrupt Status Register

**\$YFFE20**

15	14	13	12	11	10	9	8	7	6	5	4	3	2	1	0
CH 15	CH 14	CH 13	CH 12	CH 11	CH 10	CH 9	CH 8	CH 7	CH 6	CH 5	CH 4	CH 3	CH 2	CH 1	CH 0
RESET:															
0	0	0	0	0	0	0	0	0	0	0	0	0	0	0	0

CH[15:0] — Channel Interrupt Status

0 = Channel interrupt not asserted.

1 = Channel interrupt asserted.

### D.8.12 Link Register

**LR** — Link Register

**\$YFFE22**

Used for factory test only.

### D.8.13 Service Grant Latch Register

**SGLR** — Service Grant Latch Register

**\$YFFE24**

Used for factory test only.

### D.8.14 Decoded Channel Number Register

**DCNR** — Decoded Channel Number Register

**\$YFFE26**

Used for factory test only.

### D.8.15 TPU Parameter RAM

The channel parameter registers are organized as one hundred 16-bit words of RAM. Channels 0 to 13 have six parameters. Channels 14 and 15 each have eight parameters. The parameter registers constitute a shared work space for communication between the CPU32 and the TPU. Refer to **Table D-57**.

**Table D-57 Parameter RAM Address Map**

Channel Number	Base Address	Parameter							
		0	1	2	3	4	5	6	7
0	\$YFFF## <sup>1, 2</sup>	00	02	04	06	08	0A	—	—
1	\$YFFF##	10	12	14	16	18	1A	—	—
2	\$YFFF##	20	22	24	26	28	2A	—	—
3	\$YFFF##	30	32	34	36	38	3A	—	—
4	\$YFFF##	40	42	44	46	48	4A	—	—
5	\$YFFF##	50	52	54	56	58	5A	—	—
6	\$YFFF##	60	62	64	66	68	6A	—	—
7	\$YFFF##	70	72	74	76	78	7A	—	—
8	\$YFFF##	80	82	84	86	88	8A	—	—
9	\$YFFF##	90	92	94	96	98	9A	—	—
10	\$YFFF##	A0	A2	A4	A6	A8	AA	—	—
11	\$YFFF##	B0	B2	B4	B6	B8	BA	—	—
12	\$YFFF##	C0	C2	C4	C6	C8	CA	—	—
13	\$YFFF##	D0	D2	D4	D6	D8	DA	—	—
14	\$YFFF##	E0	E2	E4	E6	E8	EA	EC	EE
15	\$YFFF##	F0	F2	F4	F6	F8	FA	FC	FE

NOTES:

1. Y = M111, where M is the logic state of the module mapping (MM) bit in the SIMCR.
2. ## = Not implemented.

## D.9 Standby RAM Module with TPU Emulation Capability (TPURAM)

**Table D-58** is the TPURAM address map. TPURAM responds to both program and data space accesses. The RASP bit in TRAMMCR determines whether the processor must be operating in supervisor mode to access the array. TPURAM control registers are accessible in supervisor mode only.

**Table D-58 TPURAM Address Map**

Address <sup>1</sup>	15	0
\$YFFB00	TPURAM Module Configuration Register (TRAMMCR)	
\$YFFB02	TPURAM Test Register (TRAMTST)	
\$YFFB04	TPURAM Base Address and Status Register (TRAMBAR)	
\$YFFB06 – \$YFFB3F	Not Used	

NOTES:

1. Y = M111, where M is the logic state of the module mapping (MM) bit in the SIMCR.

### D.9.1 TPURAM Module Configuration Register

**TRAMMCR** — TPURAM Module Configuration Register **\$YFFB00**

15	14	13	12	11	10	9	8	7	0
STOP	0	0	0	0	0	0	RASP	NOT USED	

RESET:

0 0 0 0 0 0 0 1

**STOP** — Low-Power Stop Mode Enable

0 = TPURAM operates normally.

1 = TPURAM enters low-power stop mode.

This bit controls whether TPURAM operates normally or enters low-power stop mode.

In low-power stop mode, the array retains its contents, but cannot be read or written.

**RASP** — TPURAM Array Space

0 = TPURAM is accessible in supervisor or user space.

1 = TPURAM is accessible in supervisor space only.

### D.9.2 TPURAM Test Register

**TRAMTST** — TPURAM Test Register **\$YFFB02**

Used for factory test only.

### D.9.3 TPURAM Module Configuration Register

**TRAMBAR** — TPURAM Base Address and Status Register **\$YFFB04**

15	14	13	12	11	10	9	8	7	6	5	4	3	2	1	0
ADDR 23	ADDR 22	ADDR 21	ADDR 20	ADDR 19	ADDR 18	ADDR 17	ADDR 16	ADDR 15	ADDR 14	ADDR 13	ADDR 12	0	0	0	RAMDS

RESET:

0 0 0 0 0 0 0 0 0 0 0 0 0 0 0 0



**ADDR[23:11] — TPURAM Array Base Address**

These bits specify ADDR[23:12] of the base address of the TPURAM array when enabled. The 3.5-Kbyte array resides at the lower end of the 4-Kbyte page into which it is mapped.

**RAMDS — RAM Array Disable**

0 = RAM array is enabled.

1 = RAM array is disabled.

RAMDS indicates whether the TPURAM is active or disabled. The array is disabled at reset. Writing a valid base address into TRAMBAR clears the RAMDS bit and enables the array.

## D.10 TouCAN Module

The TouCAN is used only in the MC68376. **Table D-59** shows the TouCAN address map. The column labeled “Access” indicates the privilege level at which the CPU32 must be operating to access the register. A designation of “S” indicates that supervisor mode is required. A designation of “S/U” indicates that the register can be programmed for either supervisor mode access or unrestricted access.

TouCAN module address space is split, with 128 bytes starting at the base address, and an extra 256 bytes starting at the base address +128. The upper 256 are fully used for the message buffer structures. Of the lower 128 bytes, only part is occupied by various registers. Registers with bits marked as “reserved” should always be written as logic 0.

**Table D-59 TouCAN Address Map**

Access	Address <sup>1</sup>	15	8	7	0
S	\$YFF080	TouCAN Module Configuration Register (CANMCR)			
S	\$YFF082	TouCAN Test Configuration Register (CANTCR)			
S	\$YFF084	TouCAN Interrupt Register (CANICR)			
S/U	\$YFF086	Control Register 0 (CANCTRL0)		Control Register 1 (CANCTRL1)	
S/U	\$YFF088	Prescaler Divider Register (PRES DIV)		Control Register 2 (CANCTRL2)	
S/U	\$YFF08A	Free-Running Timer Register (TIMER)			
—	—	Reserved			
S/U	\$YFF090	Receive Global Mask High (RXGMSKHI)			
S/U	\$YFF092	Receive Global Mask Low (RXGMSKLO)			
S/U	\$YFF094	Receive Buffer 14 Mask High (RX14MSKHI)			
S/U	\$YFF096	Receive Buffer 14 Mask Low (RX14MSKLO)			
S/U	\$YFF098	Receive Buffer 15 Mask High (RX15MSKHI)			
S/U	\$YFF09A	Receive Buffer 15 Mask Low (RX15MSKLO)			
—	—	Reserved			
S/U	\$YFF0A0	Error and Status Register (ESTAT)			
S/U	\$YFF0A2	Interrupt Masks (IMASK)			
S/U	\$YFF0A4	Interrupt Flags (IFLAG)			
S/U	\$YFF0A6	Receive Error Counter (RXECTR)		Transmit Error Counter (TXECTR)	

**NOTES:**

1. Y = M111, where M is the logic state of the module mapping (MM) bit in SIMCR.

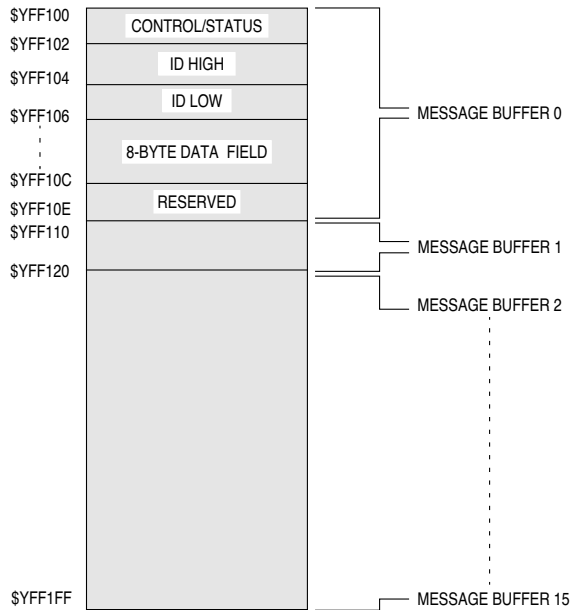

TouCAN MESSAGE BUFFER MAP

**Figure D-3 TouCAN Message Buffer Address Map**

### D.10.1 TouCAN Module Configuration Register

#### CANMCR — TouCAN Module Configuration Register

**\$YFF080**

15	14	13	12	11	10	9	8	7	6	5	4	3	2	1	0
STOP	FRZ	NOT USED	HALT	NOT RDY	WAKE MSK	SOFT RST	FRZ ACK	SUPV	SELF WAKE	APS	STOP ACK	IARB[3:0]			
RESET:															
0	1	0	1	1	0	0	1	1	0	0	0	0	0	0	0

#### STOP — Low-Power Stop Mode Enable

The STOP bit may only be set by the CPU32. It may be cleared either by the CPU32 or by the TouCAN, if the SELFWAKE bit is set.

- 0 = Enable TouCAN clocks
- 1 = Disable TouCAN clocks

#### FRZ — FREEZE Assertion Response

When FRZ = 1, the TouCAN can enter debug mode when the IMB FREEZE line is asserted, or the HALT bit is set. Clearing of this bit field causes the TouCAN to exit debug mode. Refer to **13.6.1 Debug Mode** for more information.

- 0 = TouCAN ignores the IMB FREEZE signal and the HALT bit in the module configuration register.
- 1 = Allows the TouCAN module to enter debug mode.

#### HALT — Halt TouCAN S-Clock

Setting the HALT bit has the same effect as assertion of the IMB FREEZE signal on the TouCAN without requiring that FREEZE be asserted.

This bit is set to one after reset. It should be cleared after initializing the message buffers and control registers. TouCAN message buffer receive and transmit functions are inactive until this bit is cleared.

When HALT is set, the write access to certain registers and bits that are normally read-only is allowed.

- 0 = The TouCAN operates normally.
- 1 = Place TouCAN in debug mode if FRZ = 1.

#### NOTRDY — TouCAN Not Ready

The NOTRDY bit indicates that the TouCAN is either in low-power stop mode or debug mode.

This bit is read-only and is set only when the TouCAN enters low-power stop mode or debug mode. It is cleared once the TouCAN exits either mode, either by synchronization to the CAN bus or by the self-wake mechanism.

- 0 = TouCAN has exited low-power stop mode or debug mode.
- 1 = TouCAN is in low-power stop mode or debug mode.

#### WAKEMSK — Wakeup Interrupt Mask

The WAKEMSK bit enables wake-up interrupt requests.

- 0 = Wake up interrupt is disabled.
- 1 = Wake up interrupt is enabled.

#### SOFTRST — Soft Reset

When the SOFTRST bit is asserted, the TouCAN resets its internal state machines (sequencer, error counters, error flags, and timer) and the host interface registers (CANMCR, CANICR, CANTCR, IMASK, and IFLAG).

The configuration registers that control the interface with the CAN bus are not changed (CANCTRL[0:2] and PRES DIV). Message buffers and receive message masks are also not changed. This allows SOFTRST to be used as a debug feature while the system is running.

Setting SOFTRST also clears the STOP bit in CANMCR.

After setting SOFTRST, allow one complete bus cycle to elapse for the internal TouCAN circuitry to completely reset before executing another access to CANMCR.

This bit is cleared by the TouCAN once the internal reset cycle is completed.

- 0 = Soft reset cycle completed
- 1 = Soft reset cycle initiated

#### FRZACK — TouCAN Disable

When the TouCAN enters debug mode, it sets the FRZACK bit. This bit should be polled to determine if the TouCAN has entered debug mode. When debug mode is exited, this bit is negated once the TouCAN prescaler is enabled.

This is a read-only bit.

- 0 = The TouCAN has exited debug mode and the prescaler is enabled.
- 1 = The TouCAN has entered debug mode, and the prescaler is disabled.

#### SUPV — Supervisor/User Data Space

The SUPV bit places the TouCAN registers in either supervisor or user data space.

- 0 = Registers with access controlled by the SUPV bit are accessible in either user or supervisor privilege mode.
- 1 = Registers with access controlled by the SUPV bit are restricted to supervisor mode.

#### SELFWAKE — Self Wake Enable

The SELFWAKE bit allows the TouCAN to wake up when bus activity is detected after the STOP bit is set. If this bit is set when the TouCAN enters low-power stop mode, the TouCAN will monitor the bus for a recessive to dominant transition. If a recessive to dominant transition is detected, the TouCAN immediately clears the STOP bit and restarts its clocks.

If a write to CANMCR with SELFWAKE set occurs at the same time a recessive-to-dominant edge appears on the CAN bus, the bit will not be set, and the module clocks will not stop. The user should verify that this bit has been set by reading CANMCR. Refer to **13.6.2 Low-Power Stop Mode** for more information on entry into and exit from low-power stop mode.

- 0 = Self wake disabled.
- 1 = Self wake enabled.

#### NOTE

The SELFWAKE bit should not be set if the LPSTOP instruction is to be executed because LPSTOP stops all system clocks, thus shutting down all modules.

#### APS — Auto Power Save

The APS bit allows the TouCAN to automatically shut off its clocks to save power when it has no process to execute, and to automatically restart these clocks when it has a task to execute without any CPU32 intervention.

- 0 = Auto power save mode disabled; clocks run normally.
- 1 = Auto power save mode enabled; clocks stop and restart as needed.

#### STOPACK — Stop Acknowledge

When the TouCAN is placed in low-power stop mode and shuts down its clocks, it sets the STOPACK bit. This bit should be polled to determine if the TouCAN has entered low-power stop mode. When the TouCAN exits low-power stop mode, the STOPACK bit is cleared once the TouCAN's clocks are running.

- 0 = The TouCAN is not in low-power stop mode and its clocks are running.
- 1 = The TouCAN has entered low-power stop mode and its clocks are stopped

#### IARB[3:0] — Interrupt Arbitration ID

The IARB field is used to arbitrate between simultaneous interrupt requests of the same priority. Each module that can generate interrupt requests must be assigned a unique, non-zero IARB field value.

### D.10.2 TouCAN Test Configuration Register

#### CANTCR — TouCAN Test Configuration Register

**\$YFF082**

Used for factory test only.

### D.10.3 TouCAN Interrupt Configuration Register

#### CANICR — TouCAN Interrupt Configuration Register

**\$YFF084**

15	14	13	12	11	10	9	8	7	6	5	4	3	2	1	0	
RESERVED				ILCAN[2:0]			IVBA[2:0]			RESERVED						
RESET:																
0	0	0	0	0	0	0	0	0	0	0	0	0	1	1	1	1

#### ILCAN[2:0] — Interrupt Request Level

When the TouCAN generates an interrupt request, ILCAN[2:0] determines which of the interrupt request signals is asserted. When a request is acknowledged, the TouCAN compares ILCAN[2:0] to a mask value supplied by the CPU32 to determine whether to respond. ILCAN[2:0] must have a value in the range of \$0 (interrupts disabled) to \$7 (highest priority).

#### IVBA[2:0] — Interrupt Vector Base Address

The interrupt vector base address specifies the high-order three bits of all the vector numbers generated by the different TouCAN interrupt sources.

#### NOTE

If the TouCAN issues an interrupt request after reset and before IVBA[2:0] is initialized, it will drive \$0F as the “uninitialized” interrupt vector in response to a CPU32 interrupt acknowledge cycle, regardless of the specific event.

### D.10.4 Control Register 0

#### CANCTRL0 — Control Register 0

**\$YFF086**

15	14	13	12	11	10	9	8	7	6	5	4	3	2	1	0	
BOFF MSK	ERR MSK	RESERVED		RXMODE[1:0]		TXMODE[1:0]		CANCTRL1								
RESET:																
0	0	0	0	0	0	0	0	0	0	0	0	0	1	0	0	0

### BOFFMSK — Bus Off Interrupt Mask

The BOFFMSK bit provides a mask for the bus off interrupt.

0 = Bus off interrupt disabled.

1 = Bus off interrupt enabled.

### ERRMSK — Error Interrupt Mask

The ERRMSK bit provides a mask for the error interrupt.

0 = Error interrupt disabled.

1 = Error interrupt enabled.

### RXMODE[1:0] — Receive Pin Configuration Control

These bits control the configuration of the CANRX0 and CANRX1 pins. Refer to the **Table D-60**.

**Table D-60 RX MODE[1:0] Configuration**

Pin	RX1	RX0	Receive Pin Configuration
CANRX1 <sup>1</sup>	0	X	A logic 0 on the CANRX1 pin is interpreted as a dominant bit; a logic 1 on the CANRX1 pin is interpreted as a recessive bit
	1	X	A logic 1 on the CANRX1 pin is interpreted as a dominant bit; a logic 0 on the CANRX1 pin is interpreted as a recessive bit
CANRX0	X	0	A logic 0 on the CANRX0 pin is interpreted as a dominant bit; a logic 1 on the CANRX0 pin is interpreted as a recessive bit
	X	1	A logic 1 on the CANRX0 pin is interpreted as a dominant bit; a logic 0 on the CANRX0 pin is interpreted as a recessive bit

NOTES:

1. CANRX1 is not present on the MC68376.

### TXMODE[1:0] — Transmit Pin Configuration Control

This bit field controls the configuration of the CANTX0 and CANTX1 pins. Refer to the **Table D-61**.

**Table D-61 Transmit Pin Configuration**

TXMODE[1:0]	Transmit Pin Configuration
00	Full CMOS <sup>1</sup> ; positive polarity (CANTX0 = 0, CANTX1 = 1 <sup>2</sup> is a dominant level)
01	Full CMOS; negative polarity <sup>3</sup> (CANTX0 = 1, CANTX1 = 0 is a dominant level)
1X	Open drain <sup>4</sup> ; positive polarity

NOTES:

1. Full CMOS drive indicates that both dominant and recessive levels are driven by the chip.
2. CANTX1 is not present on the MC68376.
3. If negative polarity is activated when the LOOP bit in CANCTRL1 is set, the RX mode bit field should also be set to assure proper operation.
4. Open drain drive indicates that only a dominant level is driven by the chip. During a recessive level, the CANTX0 and CANTX1 pins are disabled (three stated), and the electrical level is achieved by external pull-up/pull-down devices. The assertion of both TX mode bits causes the polarity inversion to be cancelled (open drain mode forces the polarity to be positive).

## D.10.5 Control Register 1

### CANCTRL1 — Control Register 1

**\$YFF087**

15	14	13	12	11	10	9	8	7	6	5	4	3	2	1	0
CANCTRL0								SAMP	LOOP	TSYNC	LBUF	RSVD	PROPSEG[2:0]		
RESET:															
0	0	0	0	0	0	0	0	0	0	0	0	0	0	0	0

#### SAMP — Sampling Mode

The SAMP bit determines whether the TouCAN module will sample each received bit one time or three times to determine its value.

0 = One sample, taken at the end of phase buffer segment 1, is used to determine the value of the received bit.

1 = Three samples are used to determine the value of the received bit. The samples are taken at the normal sample point, and at the two preceding periods of the S-clock.

#### LOOP — TouCAN Loop Back

The LOOP bit configures the TouCAN to perform internal loop back. The bit stream output of the transmitter is fed back to the receiver. The receiver ignores the CANRX0 and CANRX1 pins. The CANTX0 and CANTX1 pins output a recessive state. In this state, the TouCAN ignores the ACK bit to ensure proper reception of its own messages.

0 = Internal loop back disabled.

1 = Internal loop back enabled.

#### TSYNC — Timer Synchronize Mode

The TSYNC bit enables the mechanism that resets the free-running timer each time a message is received in message buffer 0. This feature provides the means to synchronize multiple TouCAN stations with a special “SYNC” message (global network time).

0 = Timer synchronization disabled.

1 = Timer synchronization enabled.

### NOTE

There can be a bit clock skew of four to five counts between different TouCAN modules that are using this feature on the same network.

#### LBUF — Lowest Buffer Transmitted First

The LBUF bit defines the transmit-first scheme.

0 = Message buffer with lowest ID is transmitted first.

1 = Lowest numbered buffer is transmitted first.

#### PROPSEG[2:0] — Propagation Segment Time

PROPSEG defines the length of the propagation segment in the bit time. The valid programmed values are 0 to 7. The propagation segment time is calculated as follows:



$$\text{Propagation Segment Time} = (\text{PROPSEG} + 1)\text{Time Quanta}$$

where

$$1 \text{ Time Quantum} = 1 \text{ Serial Clock (S-clock) Period}$$

### D.10.6 Prescaler Divide Register

**PRESDIV** — Prescaler Divide Register

**\$YFF088**

15	14	13	12	11	10	9	8	7	6	5	4	3	2	1	0
PRESDIV								CANCTRL2							
RESET:															
0	0	0	0	0	0	0	0	0	0	0	0	1	0	0	0

**PRESDIV** — Prescaler Divide Factor

PRESDIV determines the ratio between the system clock frequency and the serial clock (S-clock).

The S-clock is determined by the following calculation:

$$\text{S-clock} = \frac{f_{\text{sys}}}{\text{PRESDIV} + 1}$$

The reset value of PRESDIV is \$00, which forces the S-clock to default to the same frequency as the system clock.

The valid programmed values are 0 through 255.

### D.10.7 Control Register 2

**CANCTRL2** — Control Register 2

**\$YFF089**

15	14	13	12	11	10	9	8	7	6	5	4	3	2	1	0
PRESDIV								RJW[1:0]		PSEG1[2:0]			PSEG2[2:0]		
RESET:															
0	0	0	0	0	0	0	0	0	0	0	0	1	0	0	0

**RJW[1:0]** — Resynchronization Jump Width

The RJW field defines the maximum number of time quanta a bit time may be changed during resynchronization.

The valid programmed values are 0 through 3.

The resynchronization jump width is calculated as follows:

$$\text{Resynchronization Jump Width} = (\text{RJW} + 1)\text{Time Quanta}$$

### PSEG1[2:0] — Phase Buffer Segment 1

The PSEG1 field defines the length of phase buffer segment 1 in the bit time.

The valid programmed values are 0 through 7.

The length of phase buffer segment 1 is calculated as follows:

$$\text{Phase Buffer Segment 1} = (\text{PSEG1} + 1)\text{Time Quanta}$$

### PSEG2 — Phase Buffer Segment 2

The PSEG2 field defines the length of phase buffer segment 2 in the bit time.

The valid programmed values are 0 through 7.

The length of phase buffer segment 2 is calculated as follows:

$$\text{Phase Buffer Segment 2} = (\text{PSEG2} + 1)\text{Time Quanta}$$

## D.10.8 Free Running Timer

### TIMER — Free Running Timer Register

**\$YFF08A**

15	14	13	12	11	10	9	8	7	6	5	4	3	2	1	0
TIMER															
RESET:															
0	0	0	0	0	0	0	0	0	0	0	0	1	0	0	0

The free running timer counter can be read and written by the CPU32. The timer starts from zero after reset, counts linearly to \$FFFF, and wraps around.

The timer is clocked by the TouCAN bit-clock. During a message, it increments by one for each bit that is received or transmitted. When there is no message on the bus, it increments at the nominal bit rate.

The timer value is captured at the beginning of the identifier field of any frame on the CAN bus. The captured value is written into the “time stamp” entry in a message buffer after a successful reception/transmission of a message.

## D.10.9 Receive Global Mask Registers

**RXGMSKHI** — Receive Global Mask Register High

**\$YFF090**

**RXGMSKLO** — Receive Global Mask Register Low

**\$YFF092**

31	30	29	28	27	26	25	24	23	22	21	20	19	18	17	16
MID28	MID27	MID26	MID25	MID24	MID23	MID22	MID21	MID20	MID19	MID18	0	1	MID17	MID16	MID15
RESET:															
1	1	1	1	1	1	1	1	1	1	1	0	1	1	1	1
15	14	13	12	11	10	9	8	7	6	5	4	3	2	1	0
MID14	MID13	MID12	MID11	MID10	MID9	MID8	MID7	MID6	MID5	MID4	MID3	MID2	MID1	MID0	0
RESET:															
1	1	1	1	1	1	1	1	1	1	1	1	1	1	1	0

The receive global mask registers use four bytes. The mask bits are applied to all receive-identifiers, excluding receive-buffers 14-15, which have their own specific mask registers.

Base ID mask bits MID[28:18] are used to mask standard or extended format frames. Extended ID bits MID[17:0] are used to mask only extended format frames.

The RTR/SRR bit of a received frame is never compared to the corresponding bit in the message buffer ID field. However, remote request frames (RTR = 1) once received, are never stored into the message buffers. RTR mask bit locations in the mask registers (bits 20 and 0) are always zero, regardless of any write to these bits.

The IDE bit of a received frame is always compared to determine if the message contains a standard or extended identifier. Its location in the mask registers (bit 19) is always one, regardless of any write to this bit.

## D.10.10 Receive Buffer 14 Mask Registers

**RX14MSKHI** — Receive Buffer 14 Mask Register High

**\$YFF094**

**RX14MSKLO** — Receive Buffer 14 Mask Register Low

**\$YFF096**

The receive buffer 14 mask registers have the same structure as the receive global mask registers and are used to mask buffer 14.

## D.10.11 Receive Buffer 15 Mask Registers

**RX15MSKHI** — Receive Buffer 15 Mask Register High

**\$YFF098**

**RX15MSKLO** — Receive Buffer 15 Mask Register Low

**\$YFF09A**

The receive buffer 15 mask registers have the same structure as the receive global mask registers and are used to mask buffer 15.

## D.10.12 Error and Status Register

### ESTAT — Error and Status Register

\$YFF0A0

15	14	13	12	11	10	9	8	7	6	5	4	3	2	1	0
BITERR[1:0]	ACK ERR	CRC ERR	FORM ERR	STUFF ERR	TX WARN	RX WARN	IDLE	TX/RX	FCS[1:0]	0	BOFF INT	ERR INT	WAKE INT		
RESET:															
0	0	0	0	0	0	0	0	0	0	0	0	0	0	0	0

This register reflects various error conditions, general status, and has the enable bits for three of the TouCAN interrupt sources. The reported error conditions are those which have occurred since the last time the register was read. A read clears these bits to zero.

#### BITERR[1:0] — Transmit Bit Error

The BITERR[1:0] field is used to indicate when a transmit bit error occurs. Refer to **Table D-62**.

**Table D-62 Transmit Bit Error Status**

BITERR[1:0]	Bit Error Status
00	No transmit bit error
01	At least one bit sent as dominant was received as recessive
10	At least one bit sent as recessive was received as dominant
11	Not used

#### NOTE

The transmit bit error field is not modified during the arbitration field or the ACK slot bit time of a message, or by a transmitter that detects dominant bits while sending a passive error frame.

#### ACKERR — Acknowledge Error

The ACKERR bit indicates whether an acknowledgment has been correctly received for a transmitted message.

0 = No ACK error was detected since the last read of this register.

1 = An ACK error was detected since the last read of this register.

#### CRCERR — Cyclic Redundancy Check Error

The CRCERR bit indicates whether or not the CRC of the last transmitted or received message was valid.

0 = No CRC error was detected since the last read of this register.

1 = A CRC error was detected since the last read of this register.

#### FORMERR — Message Format Error

The FORMERR bit indicates whether or not the message format of the last transmitted or received message was correct.

0 = No format error was detected since the last read of this register.

1 = A format error was detected since the last read of this register.

#### STUFFERR — Bit Stuff Error

The STUFFERR bit indicates whether or not the bit stuffing which occurred in the last transmitted or received message was correct.

0 = No bit stuffing error was detected since the last read of this register.

1 = A bit stuffing error was detected since the last read of this register.

#### TXWARN — Transmit Error Status Flag

The TXWARN status flag reflects the status of the TouCAN transmit error counter.

0 = Transmit error counter < 96.

1 = Transmit error counter ≥ 96.

#### RXWARN — Receiver Error Status Flag

The RXWARN status flag reflects the status of the TouCAN receive error counter.

0 = Receive error counter < 96.

1 = Receive error counter ≥ 96.

#### IDLE — Idle Status

The IDLE bit indicates when there is activity on the CAN bus.

0 = The CAN bus is not idle.

1 = The CAN bus is idle.

#### TX/RX̄ — Transmit/Receive Status

The TX/RX̄ bit indicates when the TouCAN module is transmitting or receiving a message. TX/RX̄ has no meaning when IDLE = 1.

0 = The TouCAN is receiving a message if IDLE = 0.

1 = The TouCAN is transmitting a message if IDLE = 0.

#### FCS[1:0] — Fault Confinement State

The FCS[1:0] field describes the state of the TouCAN. Refer to **Table D-63**.

**Table D-63 Fault Confinement State Encoding**

FCS[1:0]	Bus State
00	Error active
01	Error passive
1X	Bus off

If the SOFTRST bit in CANMCR is asserted while the TouCAN is in the bus off state, the error and status register is reset, including FCS[1:0]. However, as soon as the TouCAN exits reset, FCS[1:0] bits will again reflect the bus off state. Refer to **13.4.4 Error Counters** for more information on entry into and exit from the various fault confinement states.

#### BOFFINT — Bus Off Interrupt

The BOFFINT bit is used to request an interrupt when the TouCAN enters the bus off state.

0 = No bus off interrupt requested.

1 = When the TouCAN state changes to bus off, this bit is set, and if the BOFFMSK bit in CANCTRL0 is set, an interrupt request is generated. This interrupt is not requested after reset.

## ERRINT — Error Interrupt

The ERRINT bit is used to request an interrupt when the TouCAN detects a transmit or receive error.

0 = No error interrupt request.

1 = If an event which causes one of the error bits in the error and status register to be set occurs, the error interrupt bit is set. If the ERRMSK bit in CANCTRL0 is set, an interrupt request is generated.

To clear this bit, first read it as a one, then write as a zero. Writing a one has no effect.

## WAKEINT — Wake Interrupt

The WAKEINT bit indicates that bus activity has been detected while the TouCAN module is in low-power stop mode.

0 = No wake interrupt requested.

1 = When the TouCAN is in low-power stop mode and a recessive to dominant transition is detected on the CAN bus, this bit is set. If the WAKEMSK bit is set in CANMCR, an interrupt request is generated.

## D.10.13 Interrupt Mask Register

### IMASK — Interrupt Mask Register

**\$YFF0A2**

15	14	13	12	11	10	9	8	7	6	5	4	3	2	1	0
IMASKH								IMASKL							
RESET:															
0	0	0	0	0	0	0	0	0	0	0	0	0	0	0	0

IMASK contains two 8-bit fields, IMASKH and IMASKL. IMASK can be accessed with a 16-bit read or write, and IMASKH and IMASKL can be accessed with byte reads or writes.

IMASK contains one interrupt mask bit per buffer. It allows the CPU32 to designate which buffers will generate interrupts after successful transmission/reception. Setting a bit in IMASK enables interrupt requests for the corresponding message buffer.

## D.10.14 Interrupt Flag Register

### IFLAG — Interrupt Flag Register

**\$YFF0A4**

15	14	13	12	11	10	9	8	7	6	5	4	3	2	1	0
IFLAGH								IFLAGL							
RESET:															
0	0	0	0	0	0	0	0	0	0	0	0	0	0	0	0

IFLAG contains two 8-bit fields, IFLAGH and IFLAGL. IFLAG can be accessed with a 16-bit read or write, and IFLAGH and IFLAGL can be accessed with byte reads or writes.

IFLAG contains one interrupt flag bit per buffer. Each successful transmission/reception sets the corresponding IFLAG bit and, if the corresponding IMASK bit is set, an interrupt request will be generated.

To clear an interrupt flag, first read the flag as a one, and then write it as a zero. Should a new flag setting event occur between the time that the CPU32 reads the flag as a one and writes the flag as a zero, the flag will not be cleared. This register can be written to zeros only.

### D.10.15 Error Counters

**RXECTR** — Receive Error Counter

**\$YFF0A6**

**TXECTR** — Transmit Error Counter

**\$YFF0A7**

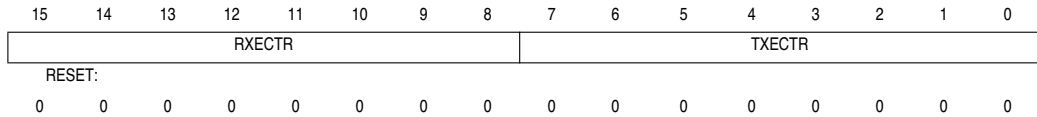

Both counters are read only, except when the TouCAN is in test or debug mode.





# INDEX

## –A–

- AC timing (electricals) A-7
- ACKERR D-94
- Acknowledge error (ACKERR) D-94
- ADDR D-83
  - bus signals 5-21
  - definition 2-8
  - signal 5-25
  - starting address D-17
- Address
  - bus (ADDR) 5-21
  - mark wakeup 9-29
  - space 8-7
    - encoding 5-23
    - maps 3-14–3-18
  - strobe ( $\overline{AS}$ ) 5-21
- Advanced Microcontroller Unit (AMCU) Literature* 1-1
- AN 8-4, 8-5
- Analog
  - front-end multiplexer 8-15
  - input
    - multiplexed 8-5
    - port A 8-4
    - port B 8-4
  - section contents 8-1
  - submodule block diagram 8-12
  - supply pins 8-6
- APS D-87
- Arbitration 9-3
- $\overline{AS}$  5-21, 5-27, 5-30, 5-37
- ASPC 7-2, 7-3, D-25
- Asserted (definition) 2-8
- ATEMP 4-20
- Auto power save (APS) D-87
- AVEC 5-14, 5-24, 5-53, 5-58
  - enable bit 5-60, D-21

## –B–

- Background
  - debug mode 4-18, 5-31
  - commands 4-21
  - connector pinout 4-25
  - enabling 4-19
  - entering 4-20
  - registers
    - fault address register (FAR) 4-22
    - instruction program counter (PCC) 4-22
    - return program counter (RPC) 4-22

- returning from 4-23
- serial
  - data word 4-25
  - I/O block diagram 4-24
  - interface 4-23
  - peripheral interface protocol (SPI) 4-24
  - sources 4-19
- debugging mode
  - freeze assertion diagram A-20
  - serial
    - communication diagram A-20
    - timing A-19
- Base ID mask bits D-93
- Basic operand size 5-25
- Baud
  - clock 9-25
  - rate generator 9-2
- BC D-76
- BCD 4-4
- Beginning of queue 2 (BQ2) D-35
- Berg connector (male) 4-25
- BERR 5-27, 5-31, 5-36, 5-37, 5-53
  - assertion results 5-35
- BG 5-38, 5-58
- BGACK 5-38, 5-58
- BGND instruction 4-20
- BH D-76
- Binary
  - coded decimal (BCD) 4-4
  - divider 8-24
  - weighted capacitors 8-15
- Bit stuff error (STUFFERR) D-95
- BITERR D-94
- BITS D-49
  - encoding field 9-17
- Bits per transfer
  - enable (BITSE) D-54
  - field (BITS) D-49
- BITSE 9-20, D-54
- Bit-time 9-25
- BIUMCR D-57
- BIUSM 10-3
  - FREEZE D-57
  - interrupt vector base number (VECT) D-57
  - LPSTOP 10-4
  - registers 10-4
    - module configuration register (BIUMCR) D-57
    - test configuration register (BIUTEST) D-58
    - time base register (BIUTBR) D-58
  - STOP 10-3, D-57
- BIUTBR D-58

BIUTEST D-58  
 BKPT 4-19, 5-31, 5-41, 5-50  
     external signal 4-20  
 BKPT (TPU asserted) D-76  
 BL D-76  
 BLC D-75  
 Block size (BLKSZ) 5-58, D-17  
     encoding 5-59, D-17  
 BM D-76  
 BME 5-15, D-13  
 BMT 5-14, D-13  
 BOFFINT D-95  
 BOFFMSK D-89  
 BOOT 7-3, D-25  
 Boot ROM  
     control( $\overline{\text{BOOT}}$ ) D-25  
 Bootstrap words (ROMBS) 7-1  
 Boundary conditions 8-19  
 BP D-76  
 BQ2 D-35  
 BR 5-37, 5-38, 5-58  
 Branch latch control (BLC) D-75  
 Break frame 9-25  
 Breakpoint  
     acknowledge cycle 5-31  
     asserted flag (BKPT) D-76  
     enable bits D-76  
     flag (PCBK) D-76  
     hardware breakpoints 5-31  
     instruction 4-18  
     mode selection 5-45  
     operation 5-33  
     software breakpoints 5-31  
 Brushless motor commutation (COMM) 11-12  
 BSA 4-19  
 BSL D-64  
 BT D-76  
 Built-in emulation memory C-1  
 Bus  
     arbitration  
         single device 5-39  
         timing diagrams  
             active A-15  
             idle A-16  
     cycle  
         regular 5-27  
         termination sequences 5-34  
     error  
         exception processing 5-36  
         signal ( $\overline{\text{BERR}}$ ) 5-14, 5-23, 5-36  
         timing of 5-36  
     grant ( $\overline{\text{BG}}$ ) 5-38  
     grant acknowledge ( $\overline{\text{BGACK}}$ ) 5-38  
     interface  
         unit submodule. *See* BIUSM 10-1, 10-3  
     monitor 5-14  
         external enable (BME) D-13  
         timeout period 5-15  
         timing (BMT) 5-14, D-13  
     off interrupt

(BOFFINT) D-95  
     mask (BOFFMSK) D-89  
     request (BR) 5-38  
     select (BSL) D-64  
     state analyzer (BSA) 4-19  
 BUSY 13-4, 13-15  
 BYP 8-14, D-37  
 Bypass mode 8-14  
 BYTE (upper/lower byte option) 5-59, D-18

-C-

C (carry) flag 4-6, D-4  
 CAN2.0B  
     controller module. *See* TouCAN 13-1  
     protocol 13-1  
     system 13-2  
 CANCTRL0 D-88  
 CANCTRL1 D-90  
 CANCTRL2 D-91  
 CANICR D-88  
 CANMCR D-85  
 CANRX/TX pins 13-2  
 CCL D-76  
 CCR 4-6  
 CCW 8-1, 8-28, D-37  
 CF1 D-35  
 CF2 D-35  
 CFSR D-78  
 CH D-77, D-79, D-80  
 CHAN D-37  
 CHANNEL D-78  
 Channel  
     assignments  
         multiplexed D-38  
         nonmultiplexed D-38  
     conditions latch (CCL) D-76  
     control registers 11-15  
     function select registers 11-15  
     interrupt  
         base vector (CIBV) D-77  
         enable  
             /disable field (CH) D-77  
             and status registers 11-15  
         request level (CIRL) D-77  
         status (CH) D-80  
     invalid D-37  
     number (CHAN) D-37  
     orthogonality 11-4  
     priority registers 11-17  
     register breakpoint flag (CHBK) D-77  
     reserved D-37  
 CHBK D-77  
 Chip-select  
     base address  
         register boot ROM (CSBARBT) D-17  
         registers (CSBAR) 5-57, 5-58, D-17  
         reset values 5-63  
     operation 5-60  
     option

- register boot ROM (CSORBT) D-18
  - registers (CSOR) 5-57, 5-59, D-18
    - reset values 5-63
- pin
  - assignment registers (CSPAR) 5-57, D-15
    - field encoding 5-58, D-16
  - pin
    - assignments D-16
  - reset operation 5-62
  - signals for interrupt acknowledge 5-61
  - timing diagram A-18
- CIBV D-77
- CIE1 D-32
- CIE2 D-33
- CIER 11-15, D-77
- CIRL D-77
- CISR 11-13, 11-15, D-80
- Clear (definition) 2-8
- CLK D-60, D-62, D-70
- CLKOUT 5-26, 5-41
  - output timing diagram A-10
- CLKRST (clock reset) 5-41
- CLKS D-75
- Clock
  - block diagram 8-24
  - control
    - multipliers 5-8
    - timing (electricals) A-3
  - generation 8-24
  - input pin status (FCSM) D-60
  - input pin status (MCSM) D-62
  - mode
    - pin (MODCLK) 5-44
    - selection 5-44
  - output (CLKOUT) 5-26
  - phase (CPHA) D-49
  - polarity (CPOL) D-49
  - rate selection (CLK) field D-70
  - synthesizer
    - control register (SYNCR) D-8
    - operation 5-5
- Code 13-4
- COF D-59, D-61
- Coherency 8-6, 8-22, 11-4
- COMM 11-12
- Command
  - RAM 9-8
  - word pointer (CWP) D-36
- Common in-circuit emulator 4-19
- Comparator 8-16
- Completed queue pointer (CPTQP) D-53
- Condition code register (CCR) 4-6, 11-5
- CONT D-54
- Contention 5-52
- Continue (CONT) D-54
- Continuous transfer mode 9-6
- Conventions 2-8
- Conversion
  - command word table (CCW) 8-1, 8-16, 8-28
  - cycle times 8-13
  - stages 8-30
- Counter
  - clock select (CLK) field
    - FCSM D-60
    - MCSM D-62
  - overflow flag (COF) bit D-59, D-61
  - prescaler submodule. *See* CPSM 10-4
- CPCR D-58
- CPHA 9-16, D-49
- CPOL 9-16, D-49
- CPR D-79
- CPSM 10-4
  - block diagram 10-4
  - registers 10-5
    - control register (CPCR) D-58
    - test register (CPTR) D-59
- CPTQP 9-8, D-53
- CPTR D-59
- CPU
  - space
    - address encoding 5-31
    - cycles 5-30
    - encoding for interrupt acknowledge 5-61
- CPU32 5-40
  - address registers/address organization in 4-5
  - addressing modes 4-9
  - block diagram 4-2
  - data registers 4-4
    - data organization 4-5
  - development support 4-17
  - exception processing 4-15
  - features 3-1
  - generated message encoding 4-25
  - instructions 4-10
    - LPSTOP 4-14
    - MOVEC 4-7
    - MOVES 4-7
    - RESET 5-41
    - special control instructions 4-14
    - table lookup and interpolate (TBL) 4-14
    - unimplemented MC68020 instructions 4-10
  - loop mode 4-15
  - memory organization 4-7
  - processing states 4-9
  - register
    - mnemonics 2-2
    - model 4-3, D-2
  - registers 4-2
    - alternate function code registers (SFC/DFC) 4-7
    - condition code register (CCR) 4-6, D-3
    - control registers 4-6
    - program counter (PC) 4-1
    - stack pointer (SP) 4-1
    - status register (SR) 4-6, D-3
    - vector base register (VBR) 4-7
  - virtual memory 4-9
- CPU32 Reference Manual* 4-1
- CR D-54
- CRCERR D-94
- CREG D-21

- CSBAR D-17
- CSBARBT D-17
- CSBOOT 5-50, 5-56, 5-58, 7-3
  - reset values 5-63
- CSOR D-18
- CSORBT D-18
- CSPAR D-15
- CTD9 D-62
- CTM Reference Manual* 10-1
- CTM2C D-62
- CTM4
  - address map 10-2, D-56
  - block diagram 10-1
  - bus interface unit submodule (BIUSM) 10-3
  - components 10-1
  - counter prescaler submodule (CPSM) 10-4
  - double-action submodule (DASM) 10-10
  - features 3-2
  - free-running counter submodule (FCSM) 10-5
  - interrupt priority and vector/pin allocation 10-18
  - interrupts 10-18
  - modulus counter submodule (MCSM) 10-5, 10-7
  - pulse width modulation submodule (PWMSM) 10-12
- CWP D-36
- Cyclic redundancy check error (CRCERR) D-94

## -D-

- DAC 8-1
- DASM 10-10
  - block diagram 10-11
  - channels 10-10
  - interrupts 10-12
  - mode flag status bit states D-64
  - modes of operation 10-10
  - registers 10-12
    - data register A (DASMA) D-66
    - data register B (DASMB) D-67
    - status/interrupt/control register (DASMSIC) D-63
  - timing (electricals) A-33
- DASMA D-66
  - operations D-67
- DASMB D-67
  - operations D-68
- DASMSIC D-63
- DATA 5-21
- Data
  - and size acknowledge ( $\overline{DSACK}$ ) 5-14, 5-23
  - bus
    - mode selection 5-42
    - signals (DATA) 5-21
  - field for RX/TX frames (TouCAN) 13-4
  - frame 9-25
  - multiplexer 5-25
  - strobe ( $\overline{DS}$ ) 5-22
  - types 4-4
- DATA (definition) 2-8
- DBcc 4-15
- DC characteristics (electricals) A-4

- DCNR D-80
- DDRE 5-64, D-10
- DDRF 5-64, D-11
- DDRQA 8-2, D-30
- DDRQS 9-4, 9-16, 9-19, D-47
- Delay
  - after transfer (DT) 9-18, D-54
  - before SCK (DSCKL) D-50
- Designated CPU space 5-22
- Development
  - support and test registers (TPU) 11-17
  - tools and support C-1
- DFC 4-7
- Digital
  - control section
    - contents 8-1, 8-16-??
  - input
    - /output port (PQA) 8-4
    - port (PQB) 8-4
    - to analog converter (DAC) 8-1, 8-15
- DIO 11-6
- DIS D-67, D-68
- Disabled mode 8-20
- Discrete input/output (DIO) 11-6
- Distributed register (DREG) D-21
- DIV8 clock 11-15
- Divide by 2/divide by 3 (DIV23) D-59
- Double
  - action submodule. See DASM 10-10
  - buffered 9-26, 9-28
  - bus fault 4-20, 5-36
  - row header 4-25
- DREG D-21
- Drive time base bus (DRV) D-60, D-61
- DRV D-60, D-61
- $\overline{DS}$  5-22, 5-27, 5-37
- $\overline{DSACK}$  5-14, 5-27, 5-31, 5-51, 5-53, 5-58, 5-60
  - assertion results 5-35
  - external/internal generation 5-30
  - option fields 5-30
  - signal effects 5-24
  - source specification in asynchronous mode 5-60, D-19
- DSCK D-55
- DSCKL D-50
- DSCLK 4-24
- DSCR D-75
- DSSR D-76
- DT D-54
- DTL D-51
- Dynamic bus sizing 5-24

## -E-

- EBI 5-52
- ECLK 5-12
  - bus timing A-21
  - output timing diagram A-10
  - timing diagram A-22
- Edge polarity (EDPOL) bit D-65

- EDGEN D-62
- EDGE P D-62
- EDIV 5-12, D-8
- EDPOL D-65
- EMPTY 13-4
- EMU 11-5, 11-15, D-74
- EMUL D-25
- Emulation
  - control (EMU) 11-15, D-74
  - mode control (EMUL) D-25
  - support 11-5
- EN D-70
- Encoded
  - one of three channel priority levels (CH) D-80
  - time function for each channel (CHANNEL) D-78
  - type of host service (CH) D-79
- Ending queue pointer (ENDQP) D-52
- End-of-
  - frame (EOF) 13-16
  - queue condition 8-30
- ENDQP 9-8, D-52
- EOF 13-16
- ERRINT D-96
- ERRMSK D-89
- Error
  - conditions 9-28
  - counters 13-9
  - detection circuitry 9-2
  - interrupt (ERRINT) D-96
  - interrupt mask (ERRMSK) D-89
- ESTAT D-94
- ETRIG 8-5
- Event flag (FLAG) D-63
- Event timing 11-3
- Exception
  - instruction (RTE) 5-36
  - processing 4-15, 5-40
    - sequence 4-17
    - types of exceptions 4-17
    - vectors 4-15
      - exception vector assignments 4-16
    - vector 5-40, 11-6
- EXOFF D-6
- EXT D-9
- Extended message format 13-1
  - frames 13-4
- External
  - bus
    - arbitration 5-38
    - clock
      - division (EDIV) D-8
      - division bit (EDIV) 5-12
      - operation during LPSTOP 5-12
      - signal (ECLK) 5-12
    - interface (EBI) 5-19
      - control signals 5-21
    - clock input timing diagram A-10
    - clock off (EXOFF) D-6
    - digital supply pin 8-6
    - multiplexing 8-10
    - reset (EXT) D-9
    - trigger pins 8-5
  - Externally
    - input clock frequency D-14
    - multiplexed mode (MUX) D-31
- EXTRST (external reset) 5-48

**-F-**

- Factory test 5-64
- FAR 4-22
- Fast
  - quadrature decode (FQD) 11-12
    - reference 5-4
      - circuit 5-5
    - termination
      - cycles 5-26, 5-30
      - read cycle timing diagram A-13
      - write cycle timing diagram A-14
- Fast reference frequency D-14
- Fault confinement state (FCS) 13-10, D-95
- FC 5-22
- FCS 13-10, D-95
- FCSM 10-5
  - block diagram 10-5
  - clock sources 10-6
  - counter 10-6
  - external event counting 10-6
  - interrupts 10-6
  - registers 10-7
    - counter register (FCSMCNT) D-61
    - status/interrupt/control register (FCSMSIC) D-59
  - time base bus drivers 10-6
  - timing (electricals) A-31
- FCSMCNT D-61
- FCSMSIC D-59
- FE 9-28, D-46
- Final sample time 8-13
- FLAG D-63, D-68
- FORCA D-65
- FORCB D-65
- Force (FORCA/B) D-65
- FORMERR D-94
- f<sub>PWM</sub> 10-16
- f<sub>QCLK</sub> 8-24
- FQD 11-12
- FQM 11-13
- Frame 9-25
  - size 9-28
- Frames
  - overload 13-16
  - remote 13-15
- Framing error (FE) flag 9-28, D-46
- Free-running counter submodule. *See* FCSM 10-5
- FREEZ ACK 13-16
- FREEZE
  - assertion response (FRZ)
    - BIUSM 10-3, D-57
    - QADC 8-7, D-29

QSM 9-3, D-41  
 SIM 5-3  
 TouCAN D-85  
 TPU D-75  
 bus monitor (FRZBM) 5-3, D-7  
 software enable (FRZSW) 5-3, D-7  
 Frequency  
 control  
     counter (Y) D-8  
     prescaler (X) D-8  
     VCO (W) D-8  
     measurement (FQM) 11-13  
 FRZ 8-7, 13-11, D-29, D-41, D-75, D-85  
 FRZACK 13-11, D-87  
 FRZBM 5-3, D-7  
 FRZSW 5-3, D-7  
 $f_{\text{sys}}$  8-25, 10-16, D-8  
 F-term encoding 5-30  
 FULL 13-4  
 Function  
     code (FC) signals 5-22, 5-30  
     library for TPU 11-5

## -G-

Global registers 8-2

## -H-

Hall effect decode (HALLD) 11-13  
 HALLD 11-13  
 HALT 13-11, D-52, D-86  
 $\overline{\text{HALT}}$  5-15, 5-23, 5-27, 5-37  
     assertion results 5-35  
 Halt  
     acknowledge flag (HALTA) D-53  
     monitor  
         enable (HME) 5-15, D-13  
         reset (HLT) D-9  
     operation 5-37  
         negating/reasserting 5-37  
     QSPI (HALT) D-52  
     TouCAN S-clock (HALT) D-86  
 HALTA D-53  
 HALTA/MODF interrupt enable (HMIE) bit D-52  
 Handshaking 5-26  
 Hang on T4 (HOT4) D-75  
 Hardware breakpoints 5-31  
 HLT D-9  
 HME 5-15, D-13  
 HMIE D-52  
 Host  
     sequence registers 11-16  
     service registers 11-17  
 HOT4 D-75  
 HSQR D-78  
 HSSR D-79  
 Hysteresis 5-51

## -I-

I/O port operation 8-8  
 IARB  
     BIUSM D-58  
     QADC 8-8, D-29  
     QSM D-41  
     SIM 5-2, 5-3, 5-52, D-7  
     TouCAN D-88  
     TPU 11-5, D-75  
 IARB3 D-60, D-61, D-64, D-69  
 IC D-67, D-68  
 ICD16/ICD32 C-1  
 ID  
     Extended (IDE) field 13-5  
     HIGH field 13-5  
     LOW field 13-5  
 $I_{\text{DD}}$  5-46  
 IDE 13-5  
 Identifier (ID) 13-1  
     bit field 13-6  
 IDLE 9-28, D-45, D-95  
 Idle  
     CAN status (IDLE) D-95  
     frame 9-25  
     -line  
         detect type (ILT) D-43  
         detected (IDLE) 9-28, D-45  
         detection process 9-28  
         interrupt enable (ILIE) 9-29, D-44  
         type (ILT) bit 9-29  
 IFLAG D-96  
 IL D-60, D-61, D-64, D-69  
 ILIE 9-29, D-44  
 ILQSPI D-42  
 ILSCI D-42  
 ILT 9-29, D-43  
 IMASK D-96  
 IMB 8-1, 10-1  
 IN D-60, D-64  
 IN1 D-62  
 IN2 D-62  
 In-circuit debugger (ICD16/ICD32) C-1  
 Information processing time (IPT) 13-9  
 Initial sample time 8-13  
 Input  
     capture/input transition counter (ITC) 11-6  
     pin status (IN)  
         DASM D-64  
     sample time (IST) 8-26, D-37  
 Interchannel communication 11-4  
 Intermission 13-16  
 Intermodule bus (IMB) 3-3, 8-1, 10-1  
 Internal  
     bus  
         error ( $\overline{\text{BERR}}$ ) 5-14, 5-15  
         monitor 5-14  
         clock signals (PCLK) D-62  
         register map 3-13  
 Interrupt

- acknowledge
  - and arbitration 5-52
  - bus cycles 5-54
- arbitration 5-2, 9-3
  - IARB field
    - BIUSM D-58
    - QADC 8-8, D-29
    - QSM D-41
    - SIM 5-2, 5-3, 5-52, D-7
    - TouCAN D-88
    - TPU 11-5, D-75
  - IARB3 bit
    - DASM D-64
    - FCSM D-60
    - MCSM D-61
    - PWMSM D-69
- exception processing 5-50
- initializing 8-34
- level (IL)
  - DASM D-64
  - FCSM D-60
  - for QSPI (ILQSPI) D-42
  - for SCI (ILSCI) D-42
  - MCSM D-61
  - PWMSM D-69
- priority
  - and recognition 5-51
  - level field (IPL) 5-60, D-20
  - mask (IP) field 4-6, 5-51, 9-3, 11-5, D-4
- processing summary 5-53
- request level (IRL) bit field D-88
- sources 8-32
- vector
  - base (IVB) field D-30
  - base address (IVBA) field D-88
  - number 9-3
  - field (INTV) D-42
- vectors for QADC 8-33
- Interrupts
  - CTM4 10-18
  - DASM 10-12
  - FCSM 10-6
  - MCSM 10-9
  - QADC 8-32
  - QSM 9-3
  - SIM 5-50
  - TouCAN 13-19
  - TPU 11-5
- Inter-transfer delay 9-6
- INTV D-42
- Invalid channel number D-37
- IP 9-3, 11-5
- IPL D-20
- IPM D-67, D-68
- IPT 13-9
- IPWM D-67, D-68
- IRL D-88
- IRLQ1 D-29
- IRLQ2 D-29
- $\overline{IRQ}$  5-51, 5-53, 11-5
- ISB 6-2
- IST 8-26, D-37
- ITC 11-6
- IVB 8-33, D-30
- IVBA D-88

-L-

- LBUF D-90
- Least significant bit (LSB) 8-15
- Left justified
  - signed result word table (LJSRR) D-39
  - unsigned result word table (LJURR) D-39
- Length of delay after transfer (DTL) D-51
- Level-sensitivity 5-51
- LJSRR D-39
- LJURR D-39
- LOAD D-69
- LOC D-9
- LOCK 7-3, D-25
- Lock
  - /release/busy mechanism 13-15
  - registers (LOCK) D-25
- Logic
  - analyzer pod connectors C-2
  - levels (definition) 2-8
- LOOP D-90
- Loop
  - back (LOOP) D-90
  - mode 4-15
  - (LOOPS) D-43
  - instruction sequence 4-15
- LOOPQ D-52
- LOOPS D-43
- Loss of clock reset (LOC) D-9
- Low power stop (LPSTOP)
  - BIUSM 10-4
  - broadcast cycle 5-34
  - CPU space cycle 5-34
  - CPU32 4-14
  - interrupt mask level 5-34
  - MRM 7-3
  - QADC 8-6
  - QSM 9-2
  - SIM 5-19
  - SRAM 6-2
  - TPU 11-15
  - TPURAM 12-3
- Lowest buffer transmitted first (LBUF) D-90
- Low-power
  - stop mode enable (STOP)
    - BIUSM D-57
    - MRM D-24
    - QADC D-28
    - QSM D-41
    - SRAM D-22
    - TouCAN D-85
    - TPU D-73
    - TPURAM D-82
- LPSTOP 4-14, 5-12, 5-19, 5-34, 10-4

LR D-80  
LSB 2-8, 4-4, 8-15  
LSW 2-8

**—M—**

M 9-25, D-44  
M68000 family  
    compatibility 4-14  
    development support 4-18  
M68MEVB1632 C-1  
    modular evaluation board (MEVB) C-1  
M68MMDS1632 C-1  
Mask  
    examples for normal/extended messages 13-8  
    registers (RX) 13-7  
Masked ROM module (MRM). *See* MRM 7-1  
Master  
    /slave mode select (MSTR) D-48  
    shift registers (TSTMSR) D-21  
Maximum  
    ratings (electrical) A-1  
MC68010 4-14  
MC68020 4-10, 4-14  
MCSM 10-5, 10-7  
    block diagram 10-8  
    clock sources 10-9  
    counter 10-8  
    external event counting 10-9  
    interrupts 10-9  
    modulus latch 10-8  
    registers 10-10  
        counter register (MCSMCNT) D-63  
        modulus latch register (MCSMML) D-63  
        status/interrupt/control register (MCSMSIC)  
            D-61  
    time base bus drivers 10-9  
    timing (electricals) A-31  
MCSMCNT D-63  
MCSMML D-63  
MCSMSIC D-61  
MCU  
    basic system 5-20  
    block diagram 3-4  
    features 3-1  
    personality board (MPB) C-1  
    pin assignment package  
        MC68336 160-pin package 3-5, B-1  
        MC68376 160-pin package 3-6, B-2  
Mechanical information B-4  
Memory  
    CPU32 organization 4-7  
    maps  
        overall memory 3-15  
        separate supervisor and user space 3-16  
        supervisor space (separate program/data  
            space) 3-17  
        user space (separate program/data space) 3-18  
    virtual 4-9  
Message

buffer  
    address map D-85  
    code for RX/TX buffers 13-4  
    deactivation 13-13  
    structure 13-3  
    format error (FORMERR) D-94  
Mid-analog supply voltage 8-15  
Misaligned operand 5-25  
MISO 9-16, 9-19  
MM 6-1, 7-1, 9-2, D-7  
MMDS C-1  
Mnemonics  
    pin and signal 2-2  
    range (definition) 2-8  
    register 2-4  
    specific (definition) 2-8  
MODCLK 5-49  
MODE 5-59, D-18, D-66  
Mode  
    fault flag (MODF) 9-9, D-53  
    select (M) D-44  
Modes  
    disabled 8-20  
    reserved 8-20  
    scan. *See* Scan modes  
MODF 9-9, D-53  
Modular platform board C-1  
Module  
    mapping (MM) bit 5-2, 6-1, 7-1, 9-2, D-6, D-7  
    pin functions 5-45  
Modulus  
    counter 9-25  
    counter submodule (MCSM). *See* MCSM 10-5, 10-7  
    load  
        edge sensitivity (EDGEN, EDGEPE) bits D-62  
        input pin status (IN1) D-62  
MOSI 9-16, 9-19  
Most significant bit (MSB) 8-15  
Motorola  
    *Microcontroller Development Tools Directory*  
        (MCUCDEVTLDIR/D Rev. 3) C-1  
    modular development system (MMDS) C-1  
MPB C-1  
MQ1 D-32  
MQ2 D-33  
MRM 7-1  
    address map D-24  
    array address mapping 7-1  
    features 3-1  
    low-power stop operation 7-3  
    normal access 7-2  
    registers  
        module configuration register (MRMCR) 7-1,  
            D-24  
    ROM  
        array base address registers (ROM-  
            BAH/BAL) 7-1, D-26  
        bootstrap words (ROMBS) 7-1, D-27  
        signature registers (RSIGHI/LO) 7-1, D-26  
    reset 7-3



ROM signature 7-3  
 MRMCR 7-1, D-24  
 MSB 2-8, 4-4, 8-15  
 MSTR D-48  
 MSTRST (master reset) 5-41, 5-48, 5-50  
 MSW 2-8  
 Multichannel pulse width modulation (MCPWM) 11-11  
 Multimaster operation 9-9  
 Multiplexed analog inputs 8-5  
 MUX 8-9, D-31

**-N-**

N (negative) flag 4-6, D-4  
 N<sub>CLOCK</sub> 10-16  
 Negated (definition) 2-8  
 New  
   input capture/transition counter (NITC) 11-11  
   queue pointer value (NEWQP) D-52  
 NEWQP 9-8, 9-20, D-52  
 NF 9-28, D-45  
 NITC 11-11  
 Noise  
   error flag (NF) D-45  
   errors 9-28  
   flag (NF) 9-28  
 Non-maskable interrupt 5-51  
 NOT ACTIVE 13-4  
 Not ready (NOTRDY) 13-3  
 NOTRDY 13-3, 13-16, D-86  
 N<sub>PERIOD</sub> 10-16  
 NRZ 9-2

**-O-**

OC 11-7  
 OCAB D-67, D-68  
 OCB D-67, D-68  
 On-chip breakpoint hardware 4-26  
 OP (1 through 3) 5-25  
 Opcode tracking 4-26  
 Open drain drivers 8-4  
 Operand  
   alignment 5-25  
   byte order 5-25  
   destination 4-4  
   misaligned 5-25  
   source 4-4  
   transfer cases 5-26  
 Operators 2-1  
 OPWM D-67, D-68  
 OR D-45  
 Ordering information B-4  
 Output  
   compare (OC) 11-7  
   driver types 3-8  
   flip-flop 10-13  
   pin  
     polarity control (POL) bit D-69

status (PIN) bit D-69  
 Overload frames 13-16  
 OVERRUN 13-4  
 Overrun error (OR) D-45

**-P-**

P D-37  
 Parallel I/O ports 5-64  
 Parentheses (definition) 2-8  
 Parity  
   (PF) flag 9-28  
   checking 9-26  
   enable (PE) D-43  
   error (PF) bit D-46  
   errors 9-28  
   type (PT) D-43  
   type (PT) bit 9-26  
 Pause (P) 8-17, D-37  
 PCBK D-76  
 PCC 4-22  
 PCLK D-62  
 PCLK6 D-59  
 PCS D-55  
   to SCK delay (DSCK) D-55  
 PCS0/SS 9-19  
 PE D-43  
 PEPAR 5-64, D-10  
 Period  
   /pulse width accumulator (PPWA) 11-9  
   and pulse width register load control (LOAD) bit D-69  
   completion status (FLAG) bit D-68  
   measurement  
     additional transition detect (PMA) 11-8  
     missing transition detect (PMM) 11-8  
 Periodic  
   /interval timer 8-27  
   interrupt  
     control register (PICR) 5-18, D-13  
     modulus counter 5-17  
     priority 5-18  
     request level (PIRQL) 5-18, D-13  
     timer 5-17  
       components 5-17  
       modulus (PITM) field 5-18  
       PIT period calculation 5-18, D-14  
       register (PITR) D-14  
       timing modulus (PITM) D-14  
       vector (PIV) 5-18, D-13  
     timer prescaler control (PTP) 5-17, D-14  
 Peripheral  
   breakpoints 4-20  
   chip-selects (PCS) 9-20, D-55  
 PF 9-28, D-46  
 PF1 D-35  
 PF2 D-35  
 PFPAR 5-64, D-11  
 Phase buffer segment 1/2 (PSEG1/2) bit field D-92  
 PICR 5-18, 5-53, D-13  
 PIE1 D-32

PIE2 D-33  
 PIN D-69  
 Pin
 

- characteristics 3-7
- electrical state 5-46
- function 5-46
- reset states 5-47

 PIRQL 5-18, D-13  
 PITM 5-18, D-14  
 Pitr 5-17, D-14  
 PIV 5-18, D-13  
 PMA 11-8  
 PMM 11-8  
 Pointer 9-6  
 POL D-69  
 Port
 

- parallel I/O in SIM 5-64
- replacement unit (PRU) C-2
- size 5-58

 Port C data register (PORTC) 5-60, D-15  
 Port E
 

- data direction register (DDRE) 5-64, D-10
- data register (PORTE) 5-64, D-10
- pin assignment register (PEPAR) 5-64, D-10

 Port F
 

- data direction register (DDRF) 5-64, D-11
- data register (PORTF) 5-64, D-11
- pin assignment register (PFPAR) 5-64, D-11

 PORTC D-15  
 PORTE 5-64, D-10  
 PORTF 5-64, D-11  
 PORTQA 8-2, D-30  
 PORTQB 8-2, D-30  
 PORTQS 9-4, D-46  
 Position-synchronized pulse generator (PSP) 11-8  
 POW D-9  
 Power
 

- connections 3-8
- consumption reduction 5-12
- up reset (POW) D-9

 PPWA 11-9  
 PQA 8-4, 8-9  
 PQB 8-4, 8-9  
 PQSPAR 9-4, 9-16, 9-19, D-47  
 Prescaler
 

- add a tick (PSA) 8-25, D-31
- clock
  - (PSCK) D-75
  - high time (PSH) 8-25, D-31
  - low time (PSL) 8-25, D-31
- control
  - for TCR1 11-13
  - for TCR2 11-14
- divide
  - factor field D-91
  - register (PRESDIV) 13-8, D-91
  - division ratio select (PSEL) D-59
  - field values for QACR0 8-25
  - running (PRUN) D-58

 PRESDIV (bit field) D-91  
 PRESDIV (register) 13-8, 13-9, D-91  
 Program counter (PC) 4-1, 4-6  
 Programmable
 

- channel service priority 11-4
- time accumulator (PTA) 11-11
- transfer length 9-6

 Propagation segment time (PROPSEG) D-90  
 PROPSEG 13-11, D-90  
 PRU C-2  
 PRUN D-58  
 PSA 8-25, 8-27, D-31  
 PSCK 11-13, D-75  
 PSEG1 D-92  
 PSEG2 13-9, 13-11, D-92  
 PSEG1S 13-11  
 PSEL D-59  
 PSH 8-25, D-31  
 PSL 8-25, D-31  
 PSP 11-8  
 PT 9-26, D-43  
 PTA 11-11  
 PTP D-14  
 Pulse width modulation
 

- submodule. See PWMSM 10-12
- TPU waveform (PWM) 11-7

 PWM 11-7
 

- duty cycle boundary cases 10-17

 PWMA D-71  
 PWMB D-71  
 PWMC D-72  
 PWMSIC D-68  
 PWMSM 10-12
 

- block diagram 10-13
- clock selection 10-13
- coherency 10-15
- counter 10-14
- enable (EN) D-70
- output flip-flop 10-13
- period registers and comparator 10-14
- pulse width registers and comparator 10-15
- PWM
  - frequency 10-16
  - period and pulse width register values 10-17
  - pulse width 10-17
- registers 10-17
  - PWM
    - counter register (PWMC) D-72
    - period register (PWMA) D-71
    - pulse width register (PWMB) D-71
    - status/interrupt/control register (PWMSIC) D-68
- timing (electricals) A-34

-Q-

- clock (QCLK) 8-14
- conversion characteristics (operating) A-30
- electrical characteristics (operating)
  - AC A-29
  - DC A-28
- features 3-2
- maximum ratings A-27
- pin functions diagram 8-3
- registers
  - control register 0 (QACR0) 8-2, 8-28, D-31
  - control register 1 (QACR0) 8-2, 8-28
  - control register 1 (QACR1) D-32
  - control register 2 (QACR0) 8-2, 8-28
  - control register 2 (QACR2) D-33
  - conversion command word table (CCW) D-37
  - interrupt register (QADCINT) 8-2, D-29
  - module configuration register (QADCMCR) 8-2, 8-6, D-28
- port
  - A data register (PORTQA) 8-2
  - B data register (PORTQB) 8-2
  - data direction register (DDRQA) 8-2
  - QA data direction register (DDRQA) D-30
  - QA data register (PORTQA) D-30
  - QB data register (PORTQB) D-30
  - result word table D-39
  - status register (QASR) 8-2, 8-28, D-35
  - test register (QADCTEST) 8-2, D-29
- QADCINT 8-2, D-29
- QADCMCR 8-2, 8-6, D-28
- QADCTEST 8-2, D-29
- QASR 8-2, 8-28, D-35
- QCLK 8-14, 8-23
  - frequency 8-24
- QDEC 11-10
- QILR 9-2, D-41
- QIVR 9-2, D-41
- QOM 11-11
- QS D-36
- QSM
  - address map 9-2, D-40
  - block diagram 9-1
  - features 3-2
  - general 9-1
  - initialization sequence 9-30
  - interrupts 9-3
  - pin function 9-4, D-48
  - QSPI 9-5
    - operating modes 9-9
    - operation 9-8
    - pins 9-8
    - RAM 9-7
    - registers 9-6
  - reference manual 9-1
  - registers
    - command RAM (CR) D-54
    - global registers 9-2
      - interrupt
        - level register (QILR) 9-2, D-41
        - vector register (QIVR) 9-2, D-41

- test register (QTEST) 9-2
- module configuration register (QSMCR) D-40
- pin control registers 9-4
- port QS
  - data direction register (DDRQS) 9-4, D-47
  - data register (PORTQS) 9-4, D-46
  - pin assignment register (PQSPAR) D-47
- QSPI
- control register 0 (SPCR0) D-48
- control register 1 (SPCR1) D-50
- control register 2 (SPCR2) D-51
- control register 3 (SPCR3) D-52
- status register (SPSR) D-52
- receive data RAM (RR) D-53
- SCI
- control register 0 (SCCR0) D-42
- control register 1 (SCCR1) D-43
- data register (SCDR) D-46
- status register (SCSR) D-45
- test register (QTEST) D-41
- transmit data RAM (TR) D-54
- types 9-2
- SCI 9-21
- operation 9-24
- pins 9-24
- registers 9-21
- QSMCR D-40
- QSPI 9-1, 9-5
- block diagram 9-5
- enable (SPE) D-50
- finished flag (SPIF) D-53
- initialization operation 9-10
- loop mode (LOOPQ) D-52
- master operation flow 9-11
- operating modes 9-9
  - master mode 9-9, 9-16
  - wraparound mode 9-19
  - slave mode 9-9, 9-19
  - wraparound mode 9-20
- operation 9-8
- peripheral chip-selects 9-20
- pins 9-8
- RAM 9-7
  - command RAM 9-8
  - receive RAM 9-7
  - transmit RAM 9-7
- registers 9-6
  - control registers 9-6
  - status register 9-7
- timing A-23
  - master A-24
  - slave A-25
- QTEST 9-2, D-41
- Quadrature decode (QDEC) 11-10
- Quad-word data 4-4
- Queue 8-16
- pointers
  - completed queue pointer (CPTQP) 9-8

- end queue pointer (ENDQP) 9-8
- new queue pointer (NEWQP) 9-8
- status (QS) D-36
- Queue 1
  - completion
    - flag (CF1) D-35
    - interrupt enable (CIE1) D-32
  - interrupt level (IRLQ1) D-29
  - operating mode (MQ1) D-32
  - pause
    - flag (PF1) D-35
    - interrupt enable (PIE1) D-32
  - single-scan enable (SSE1) D-32
  - trigger overrun (TOR1) D-35
- Queue 2
  - completion
    - flag (CF2) D-35
    - interrupt enable (CIE2) D-33
  - interrupt level (IRLQ2) D-29
  - operating mode (MQ2) D-33
  - pause
    - flag (PF2) D-35
    - interrupt enable (PIE2) D-33
  - resume (RES) D-34
  - single-scan enable bit (SSE2) D-33
  - trigger overrun (TOR2) D-36
- Queued
  - analog-to-digital converter. *See* QADC 8-1
  - output match (QOM) 11-11
  - serial
    - module (QSM). *See* QSM 9-1
    - peripheral interface (QSPI) 9-1, 9-5

**—R—**

- $\overline{R/W}$  5-22, 5-27
  - field 5-59, D-19
- RAF D-45
- RAM
  - array
    - disable (RAMDS) D-83
    - space (RASP) D-22
  - base address lock (RLCK) bit D-22
- RAMBAH 6-1, D-23
- RAMBAL 6-1, D-23
- RAMDS 12-1, D-83
- RAMMCR 6-1, D-22
- RAMTST 6-1, D-23
- RASP 6-1, D-22, D-82
  - encoding D-22
- RDR 9-24
- RDRF 9-28, D-45
- RE 9-28, D-44
- Read
  - /write signal ( $\overline{R/W}$ ) 5-22
  - cycle 5-28
  - flowchart 5-28
  - timing diagram A-11
  - system register command (RSREG) 4-20
- Receive

- data
  - (RXD) pin 9-24
  - register full (RDRF) D-45
  - error status flag (RXWARN) D-95
  - pin configuration control (RXMODE) D-89
  - RAM 9-7
  - time sample clock (RT) 9-26, 9-28
- Receiver
  - active (RAF) D-45
  - data register (RDRF) flag 9-28
  - enable (RE) 9-28, D-44
  - interrupt enable (RIE) D-44
  - wakeup (RWU) 9-29, D-44
- Reception of transmitted frames 13-13
- Remote
  - frames 13-15
  - transmission request (RTR) 13-4, 13-5
- RES 8-31, D-34
- Reserved
  - channel number D-37
  - mode 8-20
- $\overline{RESET}$  4-19, 5-40, 5-42, 5-46, 5-47
- Reset
  - control logic in SIM 5-40
  - exception processing 5-40
  - mode selection
    - timing diagram A-18
    - use in determining SIM configuration 5-41
  - module pin function out of reset 5-45
  - operation in SIM 5-40
  - power-on 5-48
  - processing summary 5-50
  - source summary in SIM 5-41
  - states of pins assigned to other MCU modules 5-47
  - status register (RSR) 5-14, 5-50, D-9
  - timing 5-47
- Resistor-divider chain 8-15
- Resolution time 8-13
- Result word table 8-1, 8-16, 8-31
- Resynchronization jump width (RJW) bit field D-91
- Retry operation 5-37
- RIE D-44
- Right justified, unsigned result word table (RJURR) D-39
- RJURR D-39
- RJW 13-11, D-91
- RLCK 6-1, D-22
- $\overline{RMC}$  3-7, 3-10, 3-12, 5-38
- ROM array space (ASPC) D-25
- ROMBAH 7-1, D-26
- ROMBAL 7-1, D-26
- ROMBS 7-1
- ROMBS0-3 D-27
- RPC 4-22
- RR D-53
- RS-232C terminal C-2
- RSIGHI 7-1, 7-3, D-26
- RSIGLO 7-1, 7-3, D-26
- RSR 5-14, D-9
- RSREG 4-20
- RT 9-28

- RTE 5-36
- RTR 13-4, 13-5, 13-15
- RWU 9-29, D-44
- RX
  - Length 13-4
- RX14MSKHI D-93
- RX14MSKLO D-93
- RX15MSKHI D-93
- RX15MSKLO D-93
- RXD 9-24
- RXECTR D-97
- RXGMSKHI D-93
- RXGMSKLO D-93
- RXMODE D-89
- RXWARN D-95

—S—

- S D-4
- SAMP D-90
- Sample amplifier bypass (BYP) D-37
- Sampling mode (SAMP) D-90
- SAR 8-1, 8-16
- SASM
  - timing (electricals) A-32
- SBK 9-27, D-44
- Scan modes
- SCBR D-43
- SCCR 9-21
- SCCR0 D-42
- SCCR1 D-43
- SCDR 9-24, D-46
- SCI 9-1, 9-2, 9-16, 9-21
  - baud
    - clock 9-25
    - rate (SCBR) D-43
    - equation D-43
  - idle-line detection 9-28
  - internal loop 9-30
  - operation 9-24
  - parity checking 9-26
  - pins 9-24
  - receiver
    - block diagram 9-23
    - operation 9-28
    - wakeup 9-29
  - registers 9-21
    - control registers (SCCR) 9-21
    - data register (SCDR) 9-24
    - status register (SCSR) 9-24
  - transmitter
    - block diagram 9-22
    - operation 9-26
- SCK 9-16, 9-19
  - actual delay before SCK (equation) 9-17
  - baud rate (equation) 9-17
- S-clock 13-8
- SCSR 9-24, D-45
- Self wake enable (SELFWAKE) D-87
- Send break (SBK) 9-27, D-44

- Serial
  - clock baud rate (SPBR) D-49
  - communication interface (SCI) 9-1, 9-21
  - formats 9-25
  - interface 4-23
  - mode (M) bit 9-25
  - shifter 9-24, 9-26
- Service
  - request breakpoint flag (SRBK) D-77
- Set (definition) 2-8
- SFC 4-7
- SGLR D-80
- SHEN 5-39, D-7
- Show cycle
  - enable (SHEN) 5-3, 5-39, D-7
  - operation 5-39
  - timing diagram A-17
- Signal
  - characteristics 3-9
  - functions 3-11
- Signature registers (RSIGHI/LO) 7-1
- SIM 5-1
  - address map D-5
  - block diagram 5-2
  - bus operation 5-26
  - chip-selects 5-54
  - external bus interface (EBI) 5-19
  - features 3-1
  - functional blocks 5-1
  - halt monitor 5-15
  - interrupt arbitration 5-3
  - interrupts 5-50
  - low-power stop operation 5-19
  - module configuration register (SIMCR) D-6
  - parallel I/O ports 5-64
  - periodic interrupt timer 5-17
    - block diagram (with software watchdog) 5-17
  - register access 5-3
  - registers
    - chip-select
      - base address
        - register boot ROM (CSBARBT) D-17
        - registers (CSBAR) 5-57, 5-58, D-17
      - option
        - register boot ROM (CSORBT) D-18
        - registers (CSOR) 5-57, 5-59, D-18
    - pin assignment registers (CSPAR) 5-57, D-15
  - clock synthesizer control register (SYNCR) D-8
  - distributed register (DREG) D-21
  - master shift register A/B (TSTMSRA/B) D-21
  - module configuration register (SIMCR) 5-2
  - periodic interrupt
    - control register (PICR) D-13
    - timer register (PITR) 5-17, D-14
  - port C data register (PORTC) 5-60, D-15
  - port E
    - data direction register (DDRE) 5-64, D-10
    - data register (PORTE) 5-64, D-10
    - pin assignment register (PEPAR) 5-64,

- D-10
- port F
  - data direction register (DDRF) 5-64, D-11
  - data register (PORTF) 5-64, D-11
  - pin assignment register (PFPAR) 5-64, D-11
- reset status register (RSR) D-9
- software service register (SWSR) D-14
- system
  - integration
    - test register - ECLK (SIMTRE) D-9
    - test register (SIMTR) D-7
  - protection control register (SYPCR) D-12
- test
  - module
    - repetition count (TSTRC) D-21
    - shift count register (TSTSC) D-21
    - submodule control register (CREG) D-21
- reset 5-40
  - state of pins 5-46
- software watchdog 5-15
  - block diagram (with PIT) 5-15
- spurious interrupt monitor 5-15
- system
  - clock 5-4
    - block diagram 5-4
    - synthesizer operation 5-5
  - configuration 5-2
  - protection 5-14
- SIM Reference Manual* 5-54
- SIMCR 5-2, 9-2, 12-1, D-6
- SIMTR D-7
- SIMTRE D-9
- SIZ 5-22, 5-25, 5-40
- Size signals (SIZ) 5-22
  - encoding 5-22
- Slave select signal ( $\overline{SS}$ ) 9-19
- SLOCK D-8
- SM 11-9
- SMB 10-1
- SOF 13-9
- Soft reset (SOFTRST) D-86
- SOFTRST 13-11, D-86
- Software
  - breakpoints 5-31
  - service register (SWSR) D-14
  - watchdog 5-15
    - block diagram 5-17
    - clock rate 5-16
    - enable (SWE) D-12
    - enable (SWE) bit 5-15
    - prescale (SWP) D-12
    - prescale (SWP) bit 5-16
    - ratio of SWP and SWT bits 5-16
    - reset (SW) D-9
    - timeout period calculation 5-16
    - timing field (SWT) 5-16, D-12
- SPACE (address space select) 5-60, D-20
- SPBR D-49
- SPCR0 D-48
- SPCR1 D-50
- SPCR2 D-51
- SPCR3 D-52
- SPE 9-6, D-50
- SPI 4-24
  - finished interrupt enable (SPIFIE) D-51
- SPIF D-53
- SPIFIE D-51
- SPSR D-52
- SPWM 11-7
- SR 4-6
- SRAM
  - address map D-22
  - array address mapping 6-1
  - features 3-1
  - normal access 6-2
  - registers
    - array base address register
      - high (RAMBAH) 6-1, D-23
      - low (RAMBAL) 6-1, D-23
    - module configuration register (RAMMCR) 6-1, D-22
    - test register (RAMTST) 6-1, D-23
  - reset 6-3
    - standby and low-power stop operation 6-2
- SRBK D-77
- SRR 13-5
- $\overline{SS}$  9-19, 9-20
- SSE1 D-32
- SSE2 D-33
- SSP 4-10
- Stack pointer (SP) 4-1
- Standard
  - message format 13-1
  - frames 13-4
  - nonreturn to zero (NRZ) 9-2
- Standby RAM module w/ TPU emulation (TPURAM). *See* TPURAM 12-1
- Start
  - bit (beginning of data frame) 9-25
  - of-frame (SOF) symbol 13-9
- State machine 8-24, 9-28
- Stepper motor (SM) 11-9
- STEXT 5-12, D-9
- STF D-75
- STOP 13-17, D-22, D-24, D-28, D-41, D-57, D-73, D-82, D-85
- Stop
  - acknowledge (STOPACK) D-87
  - clocks to TCRs (CLKS) D-75
  - enable (STOP) bit
    - BIUSM 10-3
    - QADC 8-6
    - QSM 9-2
    - SRAM 6-2
    - TouCAN 13-17
    - TPU 11-15
  - flag (STF) D-75
  - mode
    - external clock (STEXT) 5-12, D-9

- SIM clock (STSIM) 5-12, D-8
- SCI end of data frame bit 9-25
- STOPACK D-87
- STRB (address strobe/data strobe) bit 5-30, 5-60, D-19
- STSIM 5-12, D-8
- STUFFERR D-95
- Submodule bus (SMB) 10-1
- Subqueue 8-17
- Substitute remote request (SRR) 13-5
- Successive approximation register (SAR) 8-1, 8-16
- Supervisor
  - /unrestricted data space (SUPV)
    - CPU32 D-4
    - QADC D-29
    - QSM D-41
    - SIM 5-3, D-7
    - TouCAN D-87
    - TPU D-75
  - stack pointer (SSP) 4-10
- SUPV 5-3, 8-8, D-29, D-41, D-87
- SW D-9
- SWE 5-15, D-12
- SWP 5-16, D-12
- SWSR D-14
- SWT 5-16, D-12
- Symbols 2-1
- Synchronized pulse width modulation (SPWM) 11-7
- SYNCR D-8
- Synthesizer lock flag (SLOCK) D-8
- SYPCR D-12
- SYS D-9
- YSRST (system reset) 5-41
- System
  - clock 5-4
    - block diagram 5-4
    - output (CLKOUT) 5-26
    - sources 5-4
  - frequencies 5-10
  - integration
    - module. *See* SIM 5-1, D-5
    - test register - ECLK (SIMTRE) D-9
  - memory maps. *See* Memory maps 3-14
  - protection control register (SYPCR) D-12
  - reset (SYS) D-9

## -T-

- T D-3
- T2CG 11-14, D-74
- Table stepper motor (TSM) 11-10
- TBB 10-1
- TBL 4-14
- TBRs1 D-58
- TBRs2 D-58
- TC 9-27, D-45
- TCIE 9-27, D-44
- TCR D-75
- TCR1P 11-13, D-74
- TCR2 clock/gate control (T2CG) D-74
- TCR2P D-74

- TDR 9-24
- TDRE 9-27, D-45
- TE D-44
- Temporary register A (ATEMP) 4-20
- Test
  - module
    - repetition count (TSTRC) D-21
    - shift count register (TSTSC) D-21
  - submodule
    - control register (CREG) D-21
    - reset (TST) D-9
- Thermal characteristics A-2
- Three-state control (TSC) 5-49
- TICR 11-13, D-77
- TIE 9-27, D-44
- Time
  - base
    - bus driver for MCSM 10-9
    - buses (TBB) 10-1, 10-2
      - allocation 10-3
      - register bus select bits (TBRs1/0) D-58
    - processor unit. *See* TPU 11-1
    - quanta clock 13-8
    - stamp 13-4, 13-10
- TIMER D-92
- Timer
  - count register
    - 1 prescaler control (TCR1P) D-74
    - 2 prescaler control (TCR2P) D-74
  - synchronize mode (TSYNC) D-90
- TOR1 D-35
- TOR2 D-36
- TouCAN
  - address
    - map D-84
    - space 13-2
  - bit timing configuration 13-8
    - operation 13-9
  - block diagram 13-1
  - disable (FRZACK) D-87
  - external pins 13-2
  - features 3-3
  - function 13-1
  - initialization sequence 13-11
  - interrupts 13-19
  - message buffer address map D-85
  - not ready (NOTRDY) D-86
  - operation 13-3
  - receive process 13-13
  - registers
    - control register 0 (CANCTRL0) D-88
    - control register 1 (CTRL1) 13-8
    - control register 1 (CANCTRL1) D-90
    - control register 2 (CANCTRL2) D-91
    - control register 2 (CTRL2) 13-8
    - error and status register (ESTAT) D-94
    - free running timer register (TIMER) D-92
  - interrupt
    - configuration register (CANICR) D-88
    - flag register (IFLAG) D-96

- mask register (IMASK) D-96
- module configuration register (CANMCR) D-85
- receive
  - buffer 14 mask registers (RX14MSKHI/LO) D-93
  - buffer 15 mask registers (RX15MSKHI/LO) D-93
  - global mask registers (RXGMSKLO/HI) D-93
- RX/TX error counter registers (RXECTR/TXECTR) D-97
- test configuration register (CANTCR) D-88
- special operating modes 13-16
  - auto power save mode 13-18
  - debug mode 13-16
  - low-power stop mode 13-17
- transmit process 13-12
- TPU
  - A mask functions 11-6
    - discrete input/output (DIO) 11-6
    - input capture/input transition counter (ITC) 11-6
    - output compare (OC) 11-7
    - period
      - /pw accumulator (PPWA) 11-9
      - measurement
        - add transition detect (PMA) 11-8
        - missing transition detect (PMM) 11-8
      - position-synch pulse generator (PSP) 11-8
      - pulse width modulation (PWM) 11-7
      - quadrature decode (QDEC) 11-10
      - stepper motor (SM) 11-9
      - synch pw modulation (SPWM) 11-7
  - address map D-73
  - block diagram 11-1
  - components 11-2
  - features 3-2
  - FREEZE flag (TPUF) D-77
  - function library 11-5
  - G mask functions 11-10
    - brushless motor commutation (COMM) 11-12
    - fast quadrature decode (FQD) 11-12
    - frequency measurement (FQM) 11-13
    - hall effect decode (HALLD) 11-13
    - multichannel pulse width modulation (PCPWM) 11-11
    - new input capture/transition counter (NITC) 11-11
    - programmable time accumulator (PTA) 11-11
    - queued output match (QOM) 11-11
    - table stepper motor (TSM) 11-10
    - universal asynchronous receiver/transmitter (UART) 11-12
  - host interface 11-3
  - interrupts 11-5
  - microengine 11-3
  - operation 11-3
    - coherency 11-4
    - emulation support 11-5
    - event timing 11-3
    - interchannel communication 11-4
  - programmable channel service priority 11-4
  - overview 11-1
  - parameter RAM 11-3, D-80
    - address map D-81
  - registers
    - channel
      - function select registers (CFSR) D-78
    - interrupt
      - enable register (CIER) 11-5, D-77
      - status register (CISR) 11-5, D-80
    - priority registers (CPR) D-79
    - decoded channel number register (DCNR) D-80
    - development
      - support control register (DSCR) D-75
      - support status register (DSSR) D-76
    - host
      - sequence registers (HSQR) D-78
      - service request registers (HSSR) D-79
    - link register (LR) D-80
    - module configuration register (TPUMCR) D-73
    - service grant latch register (SGLR) D-80
    - test configuration register (TCR) D-75
    - TPU interrupt configuration register (TICR) D-77
  - scheduler 11-3
  - time
    - bases 11-2
    - timer channels 11-2
    - timing (electricals) A-26
- TPU Reference Manual* 11-3, 11-16, 11-17
- TPUF D-77
- TPUMCR 11-13, D-73
- TPURAM
  - address map D-82
  - array
    - address mapping 12-1
    - base address (ADDR) D-83
    - space (RASP) D-82
  - features 3-2
  - general 12-1
  - operation
    - normal 12-2
    - standby 12-2
  - privilege level 12-2
  - register block 12-1
  - registers
    - base address and status register (TRAMBAR) D-82
    - module configuration register (TRAMMCR) D-82
    - test register (TRAMTST) D-82
  - reset 12-3
  - TPU microcode emulation 12-3
- $t_{PWMAX}$  10-17
- $t_{PWMIN}$  10-17
- TR D-54
- Trace
  - enable field (T) D-3
  - on instruction execution 4-18
- TRAMBAR 12-1, D-82
- TRAMMCR 12-1, D-82



- TRAMTST 12-1, D-82
- Transfer
  - length options 9-17
  - time 8-13
- Transition-sensitivity 5-51
- Transmission
  - complete
    - (TC) flag 9-27
    - interrupt enable (TCIE) 9-27
- Transmit
  - /receive status (TX/RX) D-95
  - bit error (BITERR) D-94
  - complete
    - bit (TC) D-45
    - interrupt enable (TCIE) D-44
  - data
    - (TXD) pin 9-24
    - register empty (TDRE) flag 9-27, D-45
    - error status flag (TXWARN) D-95
    - interrupt enable (TIE) 9-27, D-44
    - pin configuration control (TXMODE) D-89
    - RAM 9-7
- Transmitter enable (TE) 9-26, D-44
- Trigger event 8-30
- TSC 5-49
- TSM 11-10
- T<sub>SR</sub> 8-6
- TST D-9
- TSTME 3-8, 3-10, 3-12
- TSTMSR D-21
- TSTRC D-21
- TSTSC D-21
- TSYNC D-90
- TX
  - Length 13-4
- TX/RX D-95
- TXD 9-24
- TXECTR D-97
- TXMODE D-89
- TXWARN D-95
- Typical ratings (electrical) A-2

-U-

- UART 11-12
- Unimplemented instruction emulation 4-18
- Universal asynchronous receiver/transmitter (UART) 11-12
- User stack pointer (USP) 4-10
- Using the TPU Function Library and TPU Emulation Mode* 11-5
- USP 4-10

-V-

- V (overflow) flag 4-6, D-4
- Variable pulse width signal generator (prescaler) 8-25
- VBR 4-7, 4-15
- V<sub>DD</sub> 3-8, 5-48, 6-1, 8-6, 12-1

- ramp time 5-48
- V<sub>DDA</sub> 3-8, 8-6
- V<sub>DDA/2</sub> 8-15
- V<sub>DDSYN</sub> 3-8, 5-48
- VECT D-57
- Vector base register (VBR) 3-14, 4-7, 4-15, 5-50
- V<sub>IH</sub> 8-8
- V<sub>IL</sub> 8-8
- Virtual memory 4-9
- Voltage
  - controlled oscillator (VCO)
    - frequency ramp time 5-48
  - reference pins 8-5
- V<sub>PP</sub> C-2
- V<sub>RH</sub> 3-8, 8-5, 8-15, D-37
- V<sub>RL</sub> 3-8, 8-5, 8-15, D-37
- V<sub>SS</sub> 3-8, 8-6, 12-2
- V<sub>SSA</sub> 3-8, 8-6
- V<sub>STBY</sub> 3-8, 6-2, 12-1, 12-2

-W-

- W bit D-8
- WAIT 7-3, D-25
- Wait states (WAIT) D-25
- WAKE 9-29, D-44
- Wake interrupt (WAKEINT) D-96
- WAKEINT 13-17, D-96
- WAKEMSK 13-17, D-86
- Wakeup
  - address mark (WAKE) 9-29, D-44
  - functions 9-2
  - interrupt mask (WAKEMSK) D-86
- Wired-OR
  - mode
    - for QSPI pins (WOMQ) D-48
    - for SCI pins (WOMS) 9-26, D-43
  - mode (WOR) D-64
- WOMQ D-48
- WOMS 9-26, D-43
- WOR D-64
- Wrap
  - enable (WREN) D-51
  - to (WRTO) D-51
- Wraparound mode 9-6
  - master 9-19
  - slave 9-20
- WREN D-51
- Write cycle 5-29
  - flowchart 5-29
  - timing diagram A-12
- WRTO D-51

-X-

- X
  - (extend) flag 4-6, D-4
  - bit in SYNCR D-8
- XTRST (external reset) 5-41

**-Y-**

Y field D-8

**-Z-**

Z (zero) flag 4-6, D-4



Компания «ЭлектроПласт» предлагает заключение долгосрочных отношений при поставках импортных электронных компонентов на взаимовыгодных условиях!

Наши преимущества:

- Оперативные поставки широкого спектра электронных компонентов отечественного и импортного производства напрямую от производителей и с крупнейших мировых складов;
- Поставка более 17-ти миллионов наименований электронных компонентов;
- Поставка сложных, дефицитных, либо снятых с производства позиций;
- Оперативные сроки поставки под заказ (от 5 рабочих дней);
- Экспресс доставка в любую точку России;
- Техническая поддержка проекта, помощь в подборе аналогов, поставка прототипов;
- Система менеджмента качества сертифицирована по Международному стандарту ISO 9001;
- Лицензия ФСБ на осуществление работ с использованием сведений, составляющих государственную тайну;
- Поставка специализированных компонентов (Xilinx, Altera, Analog Devices, Intersil, Interpoint, Microsemi, Aeroflex, Peregrine, Syfer, Eurofarad, Texas Instrument, Miteq, Cobham, E2V, MA-COM, Hittite, Mini-Circuits, General Dynamics и др.);

Помимо этого, одним из направлений компании «ЭлектроПласт» является направление «Источники питания». Мы предлагаем Вам помощь Конструкторского отдела:

- Подбор оптимального решения, техническое обоснование при выборе компонента;
- Подбор аналогов;
- Консультации по применению компонента;
- Поставка образцов и прототипов;
- Техническая поддержка проекта;
- Защита от снятия компонента с производства.



#### Как с нами связаться

**Телефон:** 8 (812) 309 58 32 (многоканальный)

**Факс:** 8 (812) 320-02-42

**Электронная почта:** [org@eplast1.ru](mailto:org@eplast1.ru)

**Адрес:** 198099, г. Санкт-Петербург, ул. Калинина, дом 2, корпус 4, литера А.