

CHS60

CH S 60 48 3R3 -

① ② ③ ④ ⑤ ⑥

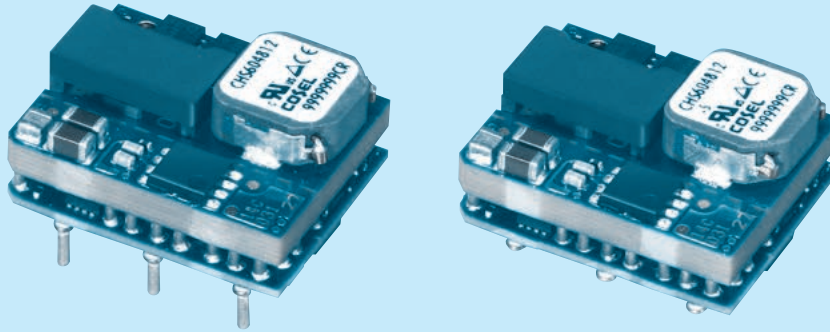
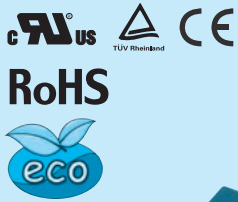

- ① Series name
- ② Single output
- ③ Output power
- ④ Input voltage
48:DC36 - 76V
- ⑤ Output voltage
3R3:3.3V
05:5.0V
12:12V
- ⑥ Optional
R :with Remote ON/OFF
Positive logic control
U :Shut down in protection
circuit working
S :SMD

MODEL	CHS60483R3	CHS604805	CHS604812
MAX OUTPUT WATTAGE[W]	59.4	60.0	72.0
DC OUTPUT	3.3V 18A	5V 12A	12V 6A

SPECIFICATIONS

	MODEL	CHS60483R3	CHS604805	CHS604812	
INPUT	VOLTAGE[V]	DC36 - 76			
	CURRENT[A]	*1 1.36typ	1.34typ	1.63typ	
	EFFICIENCY[%]	*1 91.5typ	93.0typ	92.5typ	
OUTPUT	VOLTAGE[V]	3.3	5	12	
	CURRENT[A]	18	12	6	
	LINE REGULATION[mV]	10max			
	LOAD REGULATION[mV]	10max			
	RIPPLE	[mVrms] *2	30max	30max	50max
		[mVp-p] *2	80max	100max	150max
	RIPPLE NOISE[mVp-p] *2	120max	150max	180max	
	TEMPERATURE REGULATION[mV]	66max	100max	240max	
	DRIFT[mV]	*3 16max	20max	40max	
	START-UP TIME[ms]	50max (DCIN 48V, Io=100%)			
	OUTPUT VOLTAGE ADJUSTMENT RANGE *4	Fixed (TRM pin open), adjustable by external resistor			
-10% / +15%		-10% / +20%	-20% / +10%		
OUTPUT VOLTAGE SETTING	±1.6%				
PROTECTION CIRCUIT AND OTHERS	OVERCURRENT PROTECTION	Works over 105% of rating (Auto restart)			
	OVERVOLTAGE PROTECTION	120% - 140% (Auto restart)	125% - 145% (Auto restart)	115% - 135% (Auto restart)	
	REMOTE SENSING	Provided			
	REMOTE ON/OFF	Provided (Negative Logic L : ON, H :OFF)			
ISOLATION	INPUT-OUTPUT	DC2,250V or AC1,000V 1minute, Cutoff current = 10mA, DC500V 50MΩ min (20±15°C)			
ENVIRONMENT	OPERATING TEMP.,HUMID.AND ALTITUDE	-40 to +85°C, 20 - 95%RH (Non condensing) (Refer to DERATING CURVE), 5,000m (16,000 feet) max			
	STORAGE TEMP.,HUMID.AND ALTITUDE	-40 to +100°C, 20 - 95%RH (Non condensing), 9,000m (30,000 feet) max			
	VIBRATION	10 - 55Hz, 49.0m/s ² (5G), 3minutes period, 60minutes each along X, Y and Z axis			
	IMPACT	196.1m/s ² (20G), 11ms, once each along X, Y and Z axis			
SAFETY	AGENCY APPROVALS	UL60950-1, C-UL (CSA60950-1), EN60950-1			
OTHERS	CASE SIZE/WEIGHT	19.05 X 12.7 X 23.36mm [0.75 X 0.5 X 0.92 inches] (W X H X D) / 15g max			
	COOLING METHOD	Convection / Forced air			

*1 At rated input (DC48V) and rated load. Ta=25°C, 2m/s.
 *2 Ripple and ripple noise is measured by using measuring board with ceramic capacitor 22μF.
 *3 Drift is the change in DC output for an eight hour period after a half-hour warm-up at 25°C, with the input voltage held constant at the rated input/output.
 *4 Refer to the instruction manual for input voltage derating.

External view

1. DIP

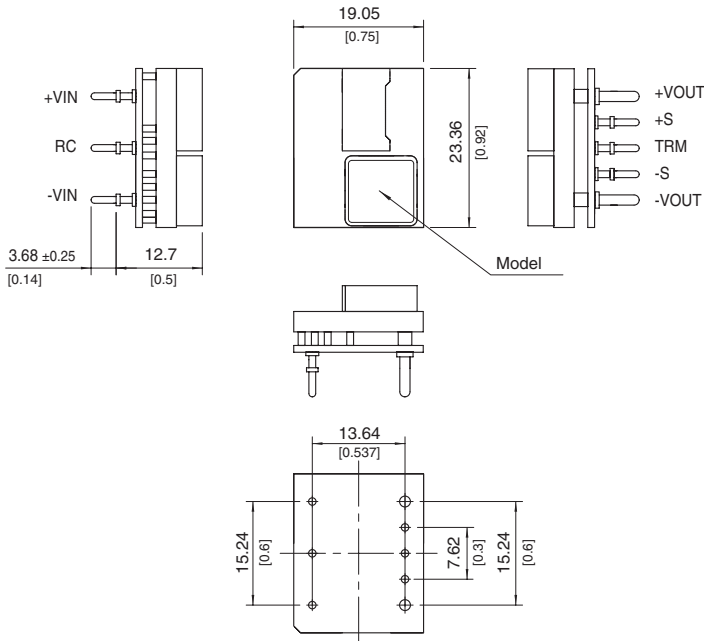

※ Tolerance: ±0.5 [±0.02]

※ Dimensions in mm, []=inches

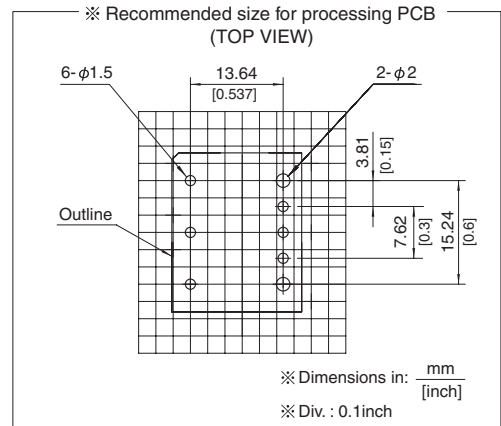
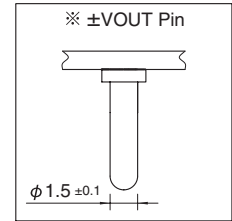
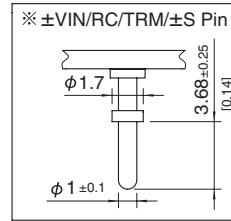

2. SMD (option S)

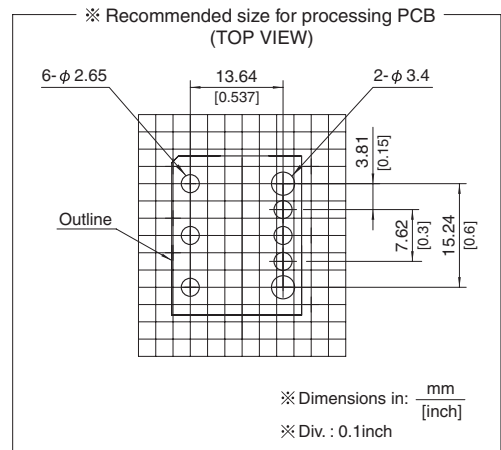
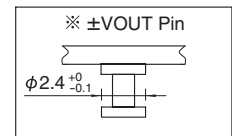
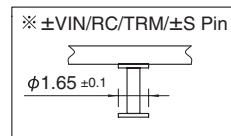
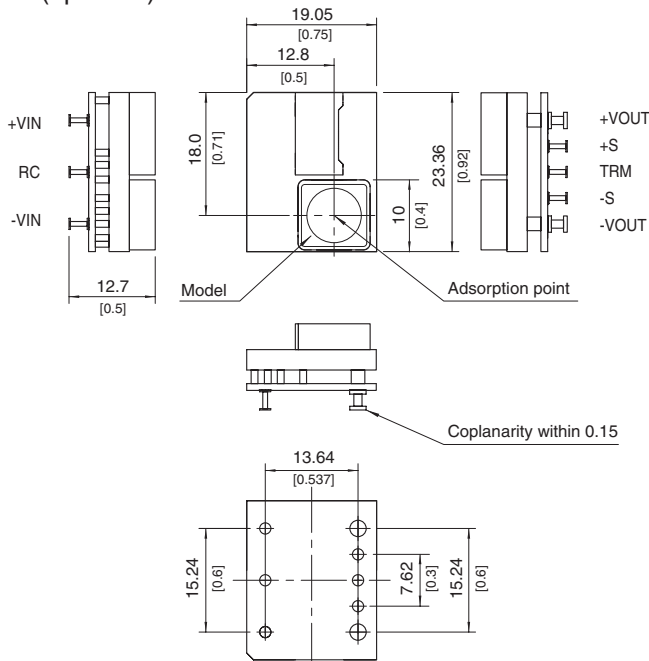

CHS80

CH S 80 48 05 -□

① ② ③ ④ ⑤ ⑥

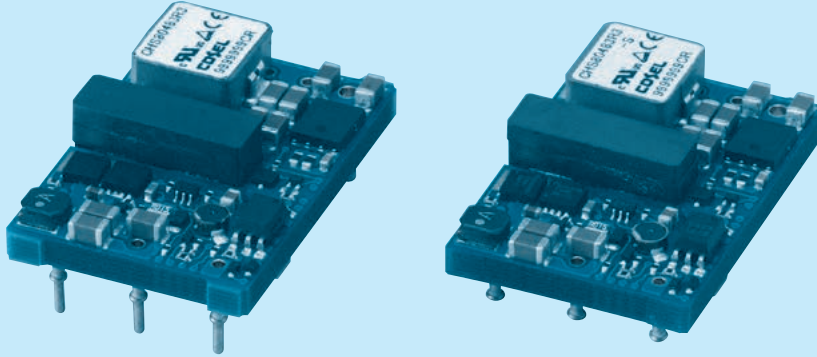
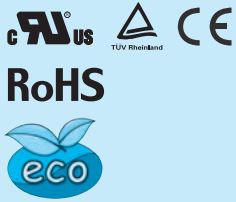

- ① Series name
- ② Single output
- ③ Output power
- ④ Input voltage
48:DC36-76V
- ⑤ Output voltage
3R3:3.3V
05:5.0V
12:12V
- ⑥ Optional
R :with Remote ON/OFF
Positive logic control
U :Shut down in protection
circuit working
S :SMD

MODEL	CHS80483R3	CHS804805	CHS804812
MAX OUTPUT WATTAGE[W]	82.5	80.0	90.0
DC OUTPUT	3.3V 25A	5.0V 16A	12V 7.5A

SPECIFICATIONS

	MODEL	CHS80483R3	CHS804805	CHS804812	
INPUT	VOLTAGE[V]	DC36 - 76			
	CURRENT[A]	*1 1.86typ	1.81typ	2.03typ	
	EFFICIENCY[%]	*1 92typ	92typ	92typ	
OUTPUT	VOLTAGE[V]	3.3	5	12	
	CURRENT[A]	25	16	7.5	
	LINE REGULATION[mV]	± 10max			
	LOAD REGULATION[mV]	± 10max			
	RIPPLE	[mVrms] *2	30max	30max	50max
		[mVp-p] *2	80max	100max	150max
	RIPPLE NOISE[mVp-p]	*2 120max	150max	180max	
	TEMPERATURE REGULATION[mV]	66max	100max	240max	
	DRIFT[mV]	*3 16max	20max	40max	
	START-UP TIME[ms]	200max (DCIN 48V, Io=100%)			
	OUTPUT VOLTAGE ADJUSTMENT RANGE	Fixed (TRM pin open), adjustable by external resistor			
	*4 -10% / +15%	-10% / +20%	-10% / +10%		
OUTPUT VOLTAGE SETTING	± 1.6%				
PROTECTION CIRCUIT AND OTHERS	OVERCURRENT PROTECTION	Works over 105% of rating (Auto restart)			
	OVERVOLTAGE PROTECTION	120% - 140% (Auto restart)	125% - 145% (Auto restart)	115% - 135% (Auto restart)	
	REMOTE SENSING	Provided			
	REMOTE ON/OFF	Provided (Negative logic L:ON, H:OFF)			
ISOLATION	INPUT-OUTPUT	DC2,250V or AC1,000V 1minute, Cutoff current = 10mA, DC500V 50MΩ min (20±15°C)			
ENVIRONMENT	OPERATING TEMP.,HUMID.AND ALTITUDE	-40 to +85°C, 20 - 95%RH (Non condensing) (Refer to DERATING CURVE), 3,000m (10,000feet) max			
	STORAGE TEMP.,HUMID.AND ALTITUDE	-40 to +100°C, 20 - 95%RH (Non condensing), 9,000m (30,000feet) max			
	VIBRATION	10 - 55Hz, 49.0m/s ² (5G), 3minutes period, 60minutes each along X, Y and Z axis			
	IMPACT	196.1m/s ² (20G), 11ms, once each along X, Y and Z axis			
SAFETY	AGENCY APPROVALS	UL60950-1, C-UL (CSA60950-1), EN60950-1			
OTHERS	CASE SIZE/WEIGHT	33.0 x 10.5 x 22.76mm [1.3 x 0.41 x 0.9 inches] (W x H x D) / 21g max			
	COOLING METHOD	Convection / Forced air			

*1 At rated input(DC48V) and rated load. Ta=25°C, 2m/s.

*2 Ripple and ripple noise is measured by using measuring board with ceramic capacitor 22 μF.

*3 Drift is the change in DC output for an eight hour period after a half-hour warm-up at 25°C, with the input voltage held constant at the rated input/output.

*4 Refer to the instruction manual for input voltage derating.

External view

1. DIP

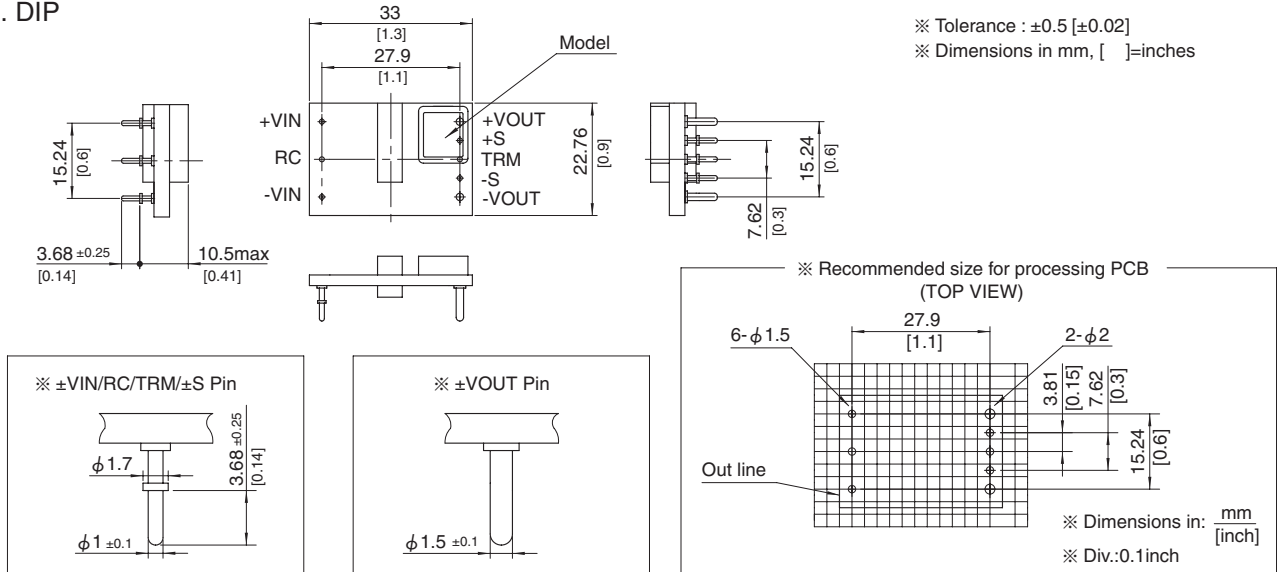

2. SMD (optionS)

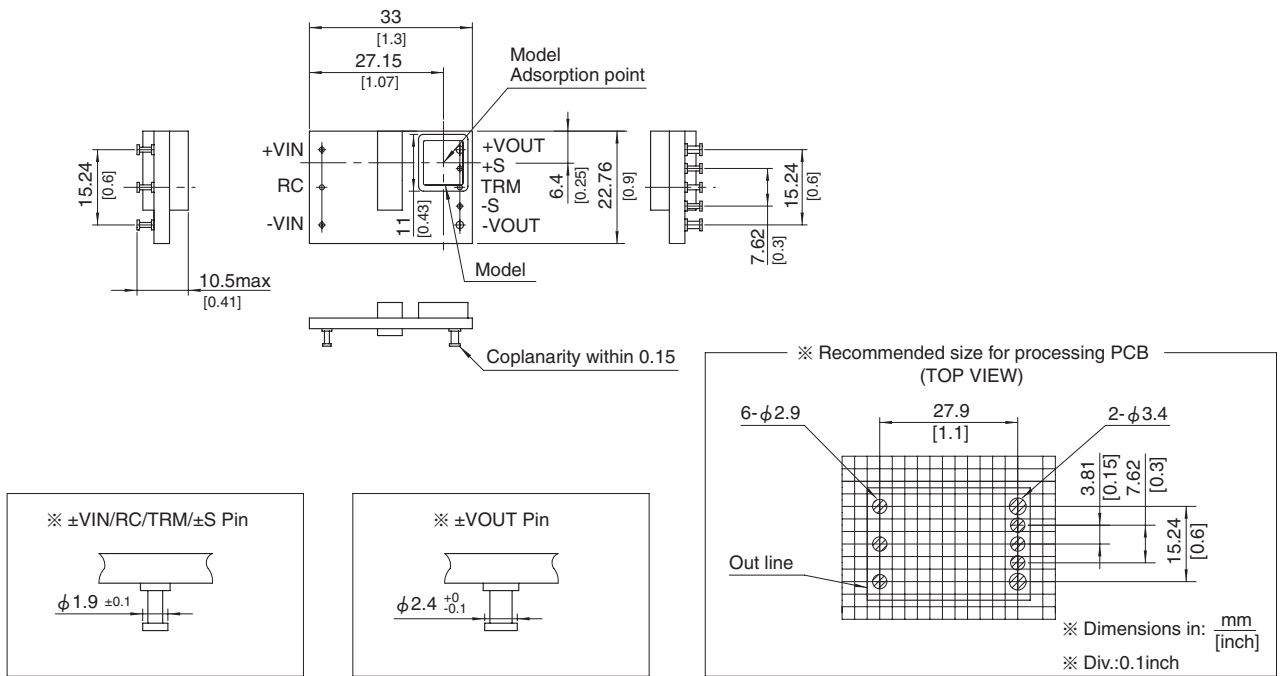

CHS120

CH S 120 48 05 -□

① ② ③ ④ ⑤ ⑥

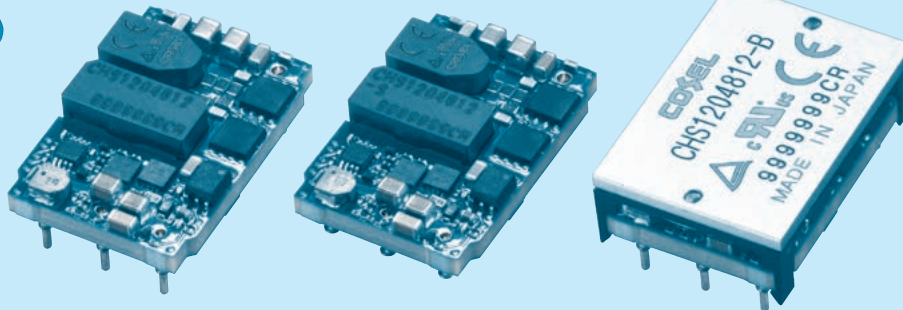

- ① Series name
- ② Single output
- ③ Output power
- ④ Input voltage
48:DC36-76V
- ⑤ Output voltage
3R3:3.3V
05:5.0V
12:12V
- ⑥ Optional
R :with Remote ON/OFF
Positive logic control
U :Shut down in protection
circuit working
S :SMD
B :BasePlate option
L2:Pin length 5.3mm
L5:5pins option
(+S,-S,TRM less)

MODEL	CHS120483R3	CHS1204805	CHS1204812
MAX OUTPUT WATTAGE[W]	99.0	120.0	120.0
DC OUTPUT	3.3V 30A	5V 24A	12V 10A

SPECIFICATIONS

	MODEL	CHS120483R3	CHS1204805	CHS1204812	
INPUT	VOLTAGE[V]	DC36 - 76			
	CURRENT[A]	*1 2.23typ	2.69typ	2.69typ	
	EFFICIENCY[%]	*1 92.5typ	93typ	93typ	
OUTPUT	VOLTAGE[V]	3.3	5	12	
	CURRENT[A]	30	24	10	
	LINE REGULATION[mV]	± 10max			
	LOAD REGULATION[mV]	± 10max			
	RIPPLE	[mVrms] *2	30max	30max	50max
		[mVp-p] *2	80max	100max	150max
	RIPPLE NOISE[mVp-p]	*2 120max	150max	180max	
	TEMPERATURE REGULATION[mV]	66max	100max	240max	
	DRIFT[mV]	*3 16max	20max	40max	
	START-UP TIME[ms]	50max (DCIN 48V, Io=100%)			
OUTPUT VOLTAGE ADJUSTMENT RANGE	Fixed (TRM pin open), adjustable by external resistor				
	*4 -10% / +15%	-10% / +20%	-10% / +10%		
OUTPUT VOLTAGE SETTING	± 1.6%				
PROTECTION CIRCUIT AND OTHERS	OVERCURRENT PROTECTION	Works over 105% of rating (Auto restart)			
	OVERVOLTAGE PROTECTION	120% - 140% (Auto restart)	125% - 145% (Auto restart)	115% - 135% (Auto restart)	
	REMOTE SENSING	Provided			
	REMOTE ON/OFF	Provided (Negative logic L:ON, H:OFF)			
ISOLATION	INPUT-OUTPUT	DC2,250V or AC1,000V 1minute, Cutoff current = 10mA, DC500V 50MΩ min (20±15°C)			
	INPUT-BASEPLATE	*5 DC2,250V or AC1,000V 1minute, Cutoff current = 10mA, DC500V 50MΩ min (20±15°C)			
	OUTPUT-BASEPLATE	*5 AC500V 1minute, Cutoff current = 10mA, DC500V 50MΩ min (20±15°C)			
ENVIRONMENT	OPERATING TEMP.,HUMID.AND ALTITUDE	-40 to +85°C, 20 - 95%RH (Non condensing) (Refer to DERATING CURVE), 5,000m (16,000feet) max			
	STORAGE TEMP.,HUMID.AND ALTITUDE	-40 to +100°C, 20 - 95%RH (Non condensing), 9,000m (30,000feet) max			
	VIBRATION	10 - 55Hz, 49.0m/s ² (5G), 3minutes period, 60minutes each along X, Y and Z axis			
	IMPACT	196.1m/s ² (20G), 11ms, once each along X, Y and Z axis			
SAFETY	AGENCY APPROVALS	UL60950-1, C-UL (CSA60950-1), EN60950-1			
OTHERS	CASE SIZE/WEIGHT	33.0 × 10.5 × 22.86mm [1.3 × 0.41 × 0.9 inches] (W × H × D) / 19g max			
	COOLING METHOD	33.5 × 12.7 × 23.36mm [1.32 × 0.5 × 0.92 inches] (W × H × D) / 28g max *5			
		Convection / Forced air / Conduction			

*1 At rated input(DC48V) and rated load. Ta=25°C, 2m/s.

*2 Ripple and ripple noise is measured by using measuring board with ceramic capacitor 22 μF.

*3 Drift is the change in DC output for an eight hour period after a half-hour warm-up at 25°C, with the input voltage held constant at the rated input/output.

*4 Refer to the instruction manual for input voltage derating.

*5 BasePlate Option.

External view

1. DIP

※ Tolerance : ±0.5
※ Dimensions in mm, []=inches

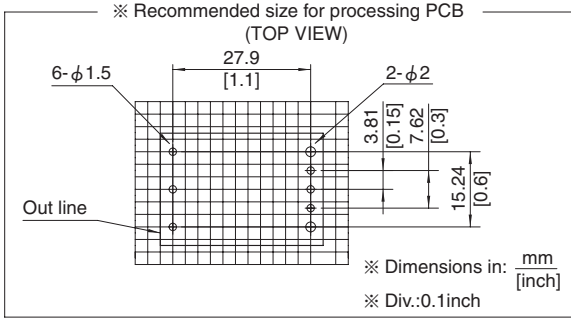
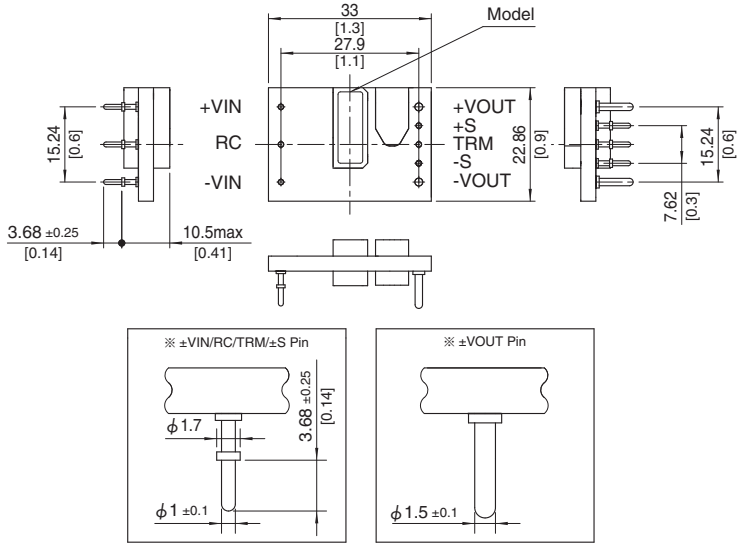

2. SMD (option S)

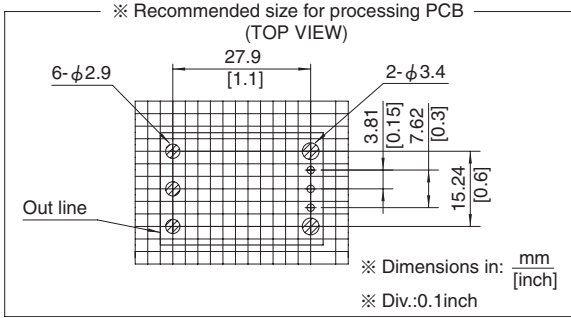
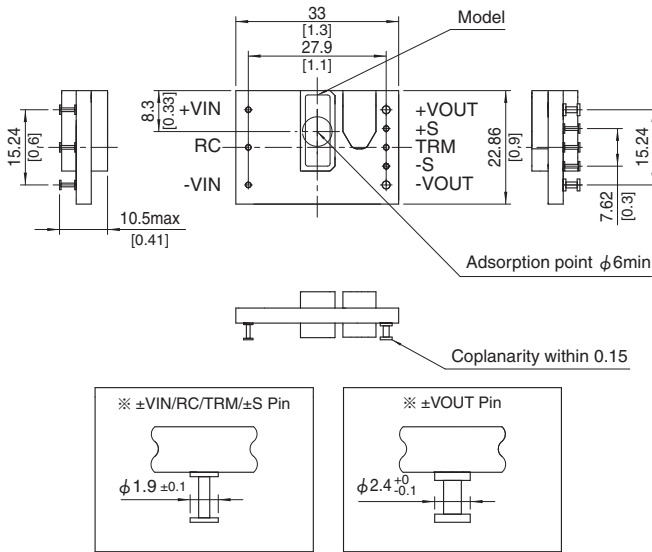

3. BasePlate (optionB)

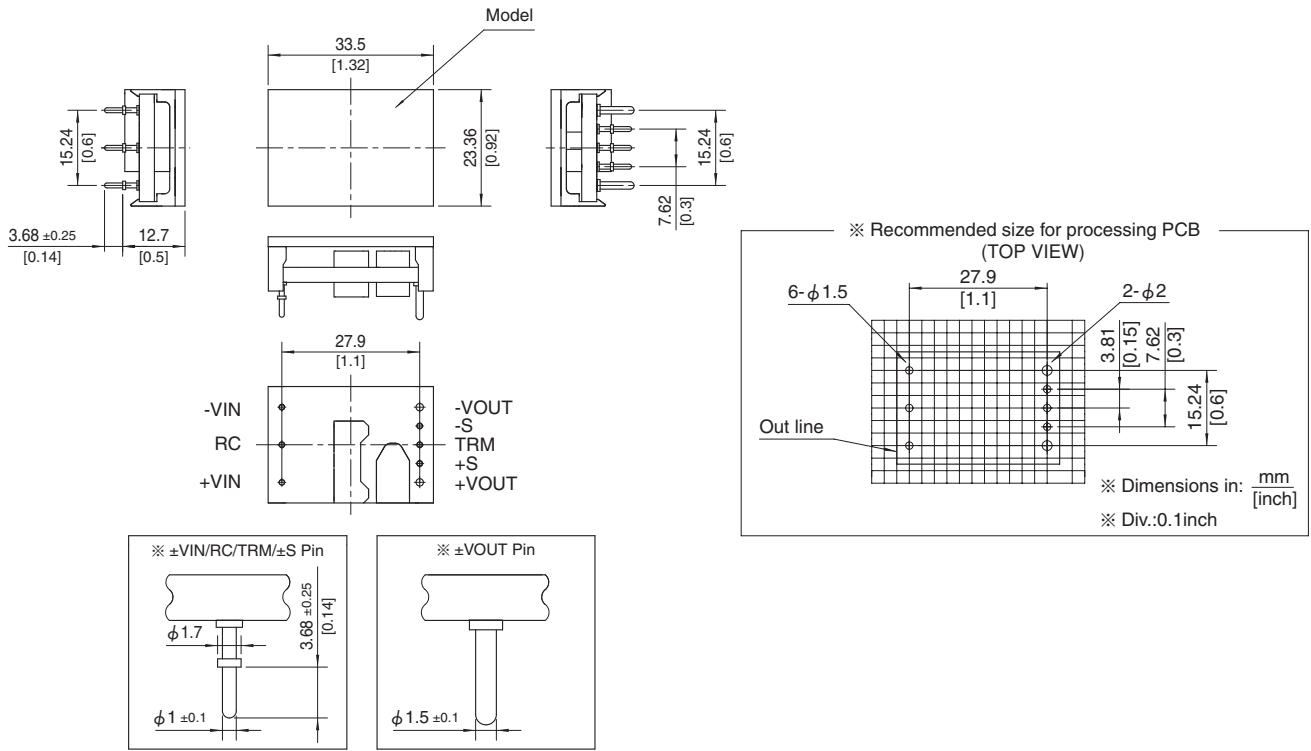

4. 5pins type (option L5)

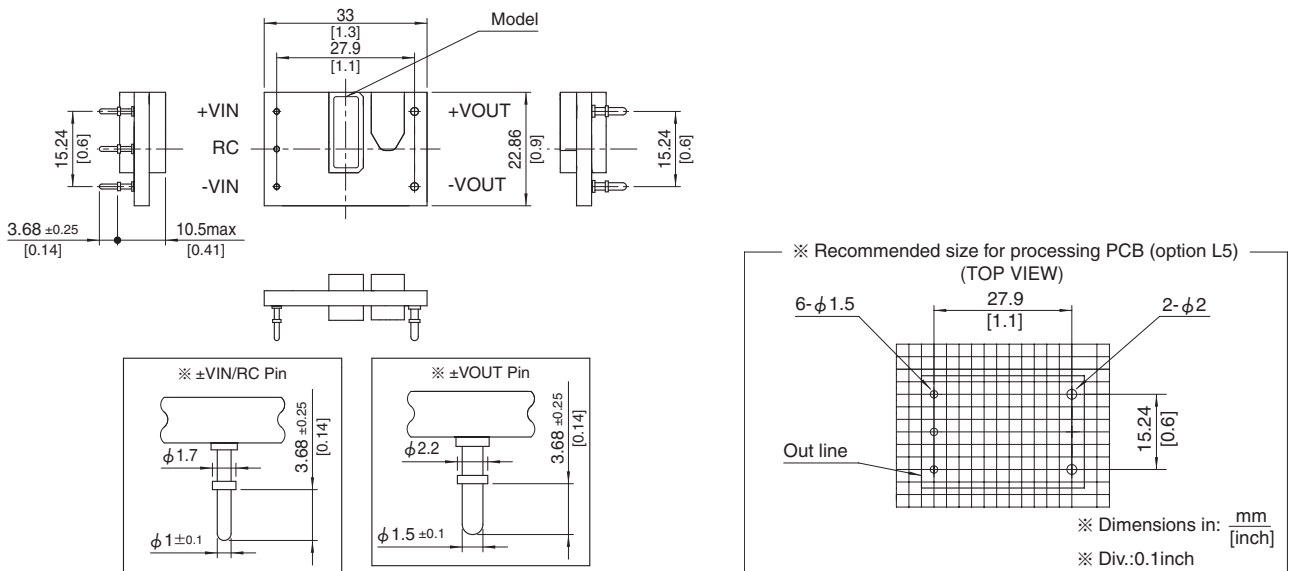

CHS200

CH S 200 48 05 -□

① ② ③ ④ ⑤ ⑥

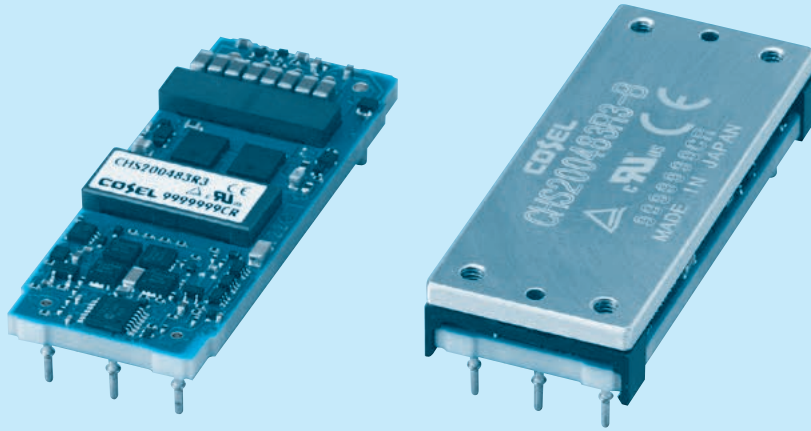
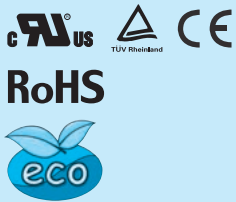

- ① Series name
- ② Single output
- ③ Output power
- ④ Input voltage
48:DC36-76V
- ⑤ Output voltage
3R3:3.3V
05:5.0V
12:12V
- ⑥ Optional
R :with Remote ON/OFF
Positive logic control
U :Shut down in protection
circuit working
B :BasePlate option with
Mounting hole M3
L2:Pin length 5.3mm
L5:5pins option
(+S,-S,TRM less)

MODEL	CHS200483R3	CHS2004805	CHS2004812
MAX OUTPUT WATTAGE[W]	165.0	200.0	192.0
DC OUTPUT	3.3V 50A	5.0V 40A	12V 16A

SPECIFICATIONS

	MODEL	CHS200483R3	CHS2004805	CHS2004812	
INPUT	VOLTAGE[V]	DC36 - 76			
	CURRENT[A]	*1 3.70typ	4.43typ	4.26typ	
	EFFICIENCY[%]	*1 93typ	94typ	94typ	
OUTPUT	VOLTAGE[V]	3.3	5	12	
	CURRENT[A]	50	40	16	
	LINE REGULATION[mV]	± 10max			
	LOAD REGULATION[mV]	± 10max			
	RIPPLE	[mVrms] *2	30max	30max	50max
		[mVp-p] *2	80max	100max	150max
	RIPPLE NOISE[mVp-p]	*2 120max	150max	180max	
	TEMPERATURE REGULATION[mV]	66max	100max	240max	
	DRIFT[mV]	*3 16max	20max	40max	
	START-UP TIME[ms]	200max (DCIN 48V, Io=100%)			
OUTPUT VOLTAGE ADJUSTMENT RANGE	Fixed (TRM pin open), adjustable by external resistor				
ADJUSTMENT RANGE	-10% / +15%	-10% / +20%	-10% / +10%		
OUTPUT VOLTAGE SETTING	± 1.6%				
PROTECTION CIRCUIT AND OTHERS	OVERCURRENT PROTECTION	Works over 105% of rating (Auto restart)			
	OVERVOLTAGE PROTECTION	120% - 140% (Auto restart)	125% - 145% (Auto restart)	115% - 135% (Auto restart)	
	REMOTE SENSING	Provided			
	REMOTE ON/OFF	Provided (Negative logic L:ON, H:OFF)			
ISOLATION	INPUT-OUTPUT	DC2,250V or AC1,000V 1minute, Cutoff current = 10mA, DC500V 50MΩ min (20±15°C)			
	INPUT-BASEPLATE	*5 DC2,250V or AC1,000V 1minute, Cutoff current = 10mA, DC500V 50MΩ min (20±15°C)			
	OUTPUT-BASEPLATE	*5 AC500V 1minute, Cutoff current = 10mA, DC500V 50MΩ min (20±15°C)			
ENVIRONMENT	OPERATING TEMP.,HUMID.AND ALTITUDE	-40 to +85°C, 20 - 95%RH (Non condensing) (Refer to DERATING CURVE), 3,000m (10,000feet) max			
	STORAGE TEMP.,HUMID.AND ALTITUDE	-40 to +100°C, 20 - 95%RH (Non condensing), 9,000m (30,000feet) max			
	VIBRATION	10 - 55Hz, 49.0m/s ² (5G), 3minutes period, 60minutes each along X, Y and Z axis			
	IMPACT	196.1m/s ² (20G), 11ms, once each along X, Y and Z axis			
SAFETY	AGENCY APPROVALS	UL60950-1, C-UL (CSA60950-1), EN60950-1			
OTHERS	CASE SIZE/WEIGHT	57.9 × 10.5 × 22.76mm [2.28 × 0.41 × 0.9 inches] (W × H × D) / 30g max			
	COOLING METHOD	58.4 × 12.7 × 23.26mm [2.3 × 0.5 × 0.92 inches] (W × H × D) / 45g max *5			
	CONDUCTION METHOD	Convection / Forced air / Conduction			

*1 At rated input(DC48V) and rated load. Ta=25°C, 2m/s.

*2 Ripple and ripple noise is measured by using measuring board with ceramic capacitor 22 μF.

*3 Drift is the change in DC output for an eight hour period after a half-hour warm-up at 25°C, with the input voltage held constant at the rated input/output.

*4 Refer to the instruction manual for input voltage derating.

*5 BasePlate Option.

External view

1. DIP

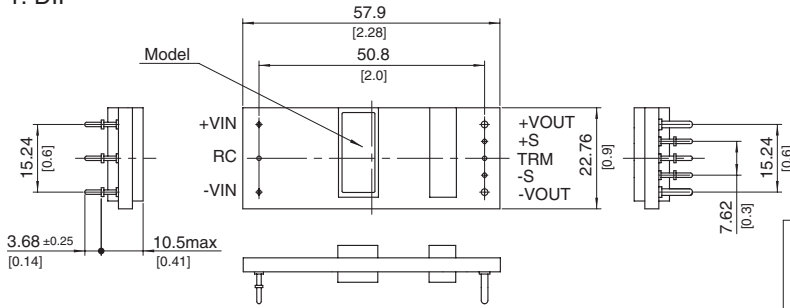

※ Tolerance : ±0.5 [±0.02]
 ※ Dimensions in mm, []=inches

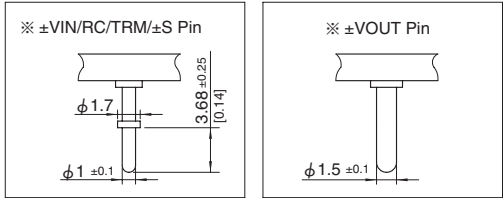

2. BasePlate (optionB)

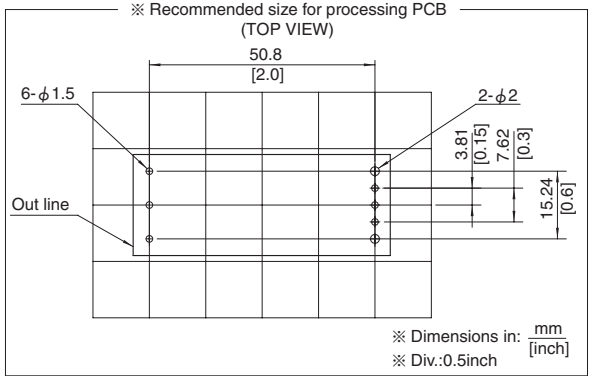
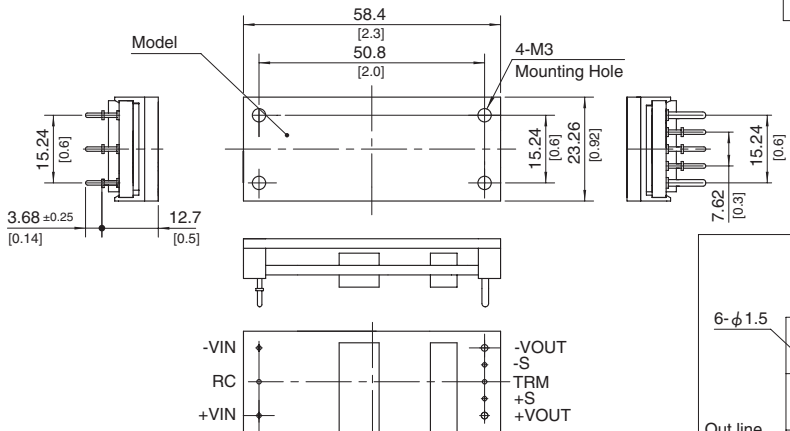

3. 5pins type (option L5)

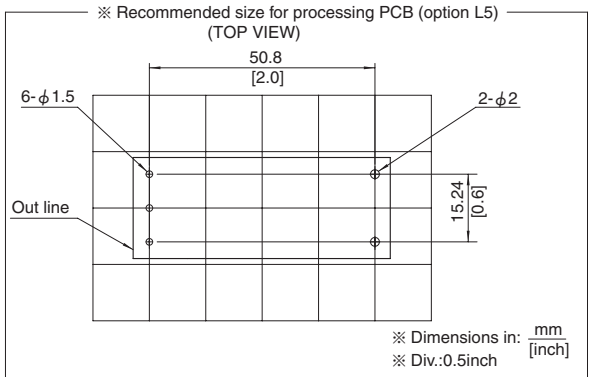
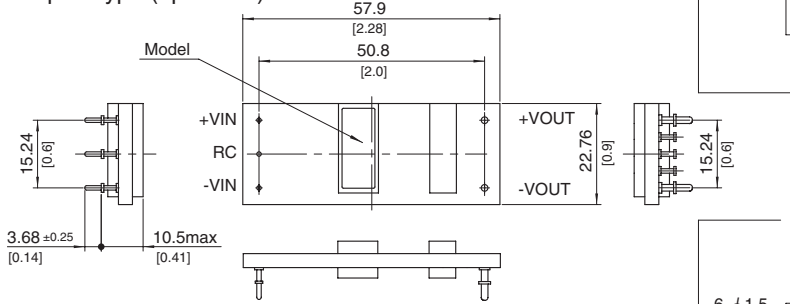

CHS300

CH S 300 48 10 - □

① ② ③ ④ ⑤ ⑥

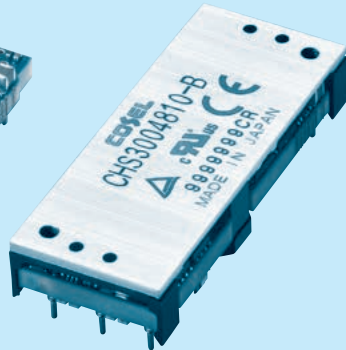
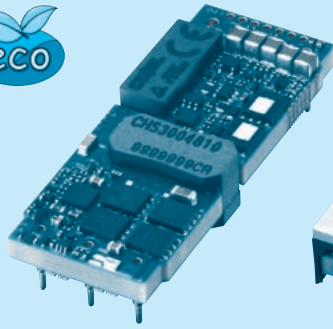

- ① Series name
- ② Single output
- ③ Output power
- ④ Input voltage
24:DC18 - 36V
48:DC36 - 76V
- ⑤ Output voltage
05:5V
10:10V
12:12V
12H:12V (High efficiency type)
15:15V
- ⑥ Optional
R :with Remote ON/OFF
Positive logic control
U :Shut down in protection
circuit working
B :Baseplate option with
mounting hole M3
BC:Baseplate and case option
with mounting hole M3
(only CHS30024)
L2:Pin length 5.3mm
L5:5pins option
(+S,-S,TRM less)
I :with the PMBus interface
(only CHS3004810/4812)

MODEL	CHS3002405	CHS3002412	CHS3002415
MAX OUTPUT WATTAGE[W]	200.0	200.4	202.5
DC OUTPUT	5V 40A	12V 16.7A	15V 13.5A

SPECIFICATIONS

	MODEL	CHS3002405	CHS3002412	CHS3002415	
INPUT	VOLTAGE[V]	DC18 - 36			
	CURRENT[A]	*1 8.91typ	9.08typ	9.02typ	
	EFFICIENCY[%]	*1 93.5typ	92.0typ	93.5typ	
OUTPUT	VOLTAGE[V]	5	12	15	
	CURRENT[A]	40	16.7	13.5	
	LINE REGULATION[mV]	10max	24max	30max	
	LOAD REGULATION[mV]	10max	24max	30max	
	RIPPLE	[mVrms] *2	40max	50max	100max
		[mVp-p] *2	120max	150max	280max
	RIPPLE NOISE[mVp-p]	*2 150max	180max	300max	
	TEMPERATURE REGULATION[mV]	120max	240max	300max	
	DRIFT[mV]	*3 20max	40max	50max	
	START-UP TIME[ms]	50max (DCIN 24V, Io=100%)			
	OUTPUT VOLTAGE ADJUSTMENT RANGE	*4 Fixed (TRM pin open), adjustable by external resistor			
OUTPUT VOLTAGE SETTING	*1 ±1.6%	-20% / +10%	-20% / +5%		
PROTECTION CIRCUIT AND OTHERS	OVERCURRENT PROTECTION	Works over 105% of rating (Auto restart)			
	OVERVOLTAGE PROTECTION	125% - 145% (Auto restart)	115% - 135% (Auto restart)	110% - 130% (Auto restart)	
	REMOTE SENSING	Provided			
	REMOTE ON/OFF	Provided (Negative Logic L : ON, H :OFF)			

MODEL	CHS3004810	CHS3004812	CHS3004812H
MAX OUTPUT WATTAGE[W]	300.0	300.0	300.0
DC OUTPUT	10V 30A	12V 25A	12V 25A

SPECIFICATIONS

	MODEL	CHS3004810	CHS3004812	CHS3004812H	
INPUT	VOLTAGE[V]	DC36 - 76			
	CURRENT[A]	*1 6.61typ	6.61typ	6.55typ	
	EFFICIENCY[%]	*1 94.5typ	94.5typ	95.5typ	
OUTPUT	VOLTAGE[V]	10	12	12	
	CURRENT[A]	30	25	25	
	LINE REGULATION[mV]	*6 20max	24max	24max	
	LOAD REGULATION[mV]	*6 20max	24max	24max	
	RIPPLE	[mVrms] *2	40max	50max	50max
		[mVp-p] *2	120max	150max	150max
	RIPPLE NOISE[mVp-p]	*2 150max	180max	180max	
	TEMPERATURE REGULATION[mV]	200max	240max	240max	
	DRIFT[mV]	*3 30max	40max	40max	
	START-UP TIME[ms]	50max (DCIN 48V, Io=100%)			
	OUTPUT VOLTAGE ADJUSTMENT RANGE	*4 Fixed (TRM pin open), adjustable by external resistor			
OUTPUT VOLTAGE SETTING	*1 ±1.6%	-10% / +10%			
PROTECTION CIRCUIT AND OTHERS	OVERCURRENT PROTECTION	Works over 105% of rating (Auto restart)			
	OVERVOLTAGE PROTECTION	115% - 135% (Auto restart)			
	REMOTE SENSING	Provided			
	REMOTE ON/OFF	Provided (Negative Logic L : ON, H :OFF)			

GENERAL SPECIFICATIONS

ISOLATION	INPUT-OUTPUT	DC2,250V or AC1,000V 1minute, Cutoff current = 10mA, DC500V 50MΩ min (20±15°C)
	INPUT-BASEPLATE *5,*7	DC2,250V or AC1,000V 1minute, Cutoff current = 10mA, DC500V 50MΩ min (20±15°C)
	OUTPUT-BASEPLATE *5,*7	AC500V 1minute, Cutoff current = 100mA, DC500V 50MΩ min (20±15°C)
ENVIRONMENT	OPERATING TEMP.,HUMID.AND ALTITUDE	-40 to +85°C, 20 - 95%RH (Non condensing) (Refer to DERATING CURVE), 5,000m (16,000 feet) max
	STORAGE TEMP.,HUMID.AND ALTITUDE	-40 to +100°C, 20 - 95%RH (Non condensing), 9,000m (30,000 feet) max
	VIBRATION	10 - 55Hz, 49.0m/s ² (5G), 3minutes period, 60minutes each along X, Y and Z axis
	IMPACT	196.1m/s ² (20G), 11ms, once each along X, Y and Z axis
SAFETY	AGENCY APPROVALS	UL60950-1, C-UL (CSA60950-1), EN60950-1
OTHERS	CASE SIZE/WEIGHT	58.4 × 11.0 × 22.86mm [2.3 × 0.43 × 0.9 inches] (W × H × D) / 38g max
		58.9 × 12.7 × 23.26mm [2.32 × 0.5 × 0.92 inches] (W × H × D) / 50g max *5
		61.1 × 14.3 × 26.1 [2.41 × 0.56 × 1.03inches] (W × H × D) / 57g max *7
	COOLING METHOD	Convection / Forced air / Conduction

*1 At rated input (DC24V, DC48V) and rated load. Ta=25°C, 2m/s.

*2 Ripple and ripple noise is measured by using measuring board with ceramic capacitor 22 μF.

*3 Drift is the change in DC output for an eight hour period after a half-hour warm-up at 25°C, with the input voltage held constant at the rated input/output.

*4 Refer to the instruction manual for input voltage derating.

*5 BasePlate Option.

*6 At input voltage DC36 - 76V (CHS3004810, CHS3004812), DC40 - 76V (CHS3004812H).

*7 Baseplate and case option.

External view

1. DIP

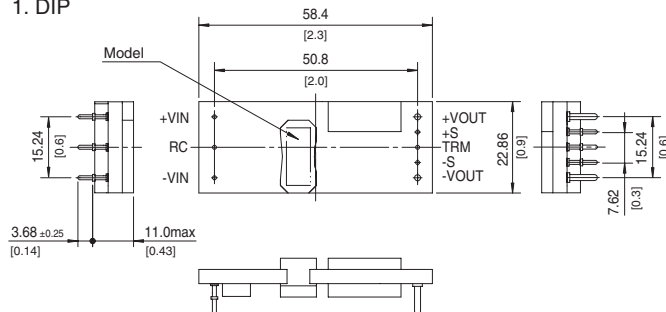

※ Tolerance: ±0.5 [±0.02]
 ※ Dimensions in mm, []=inches

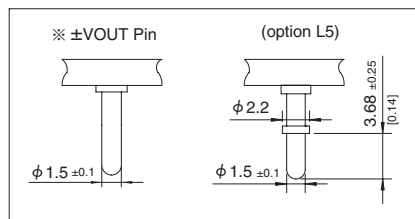

2. BasePlate (optionB)

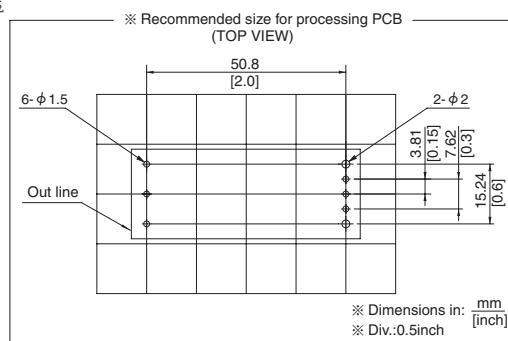
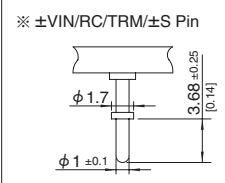
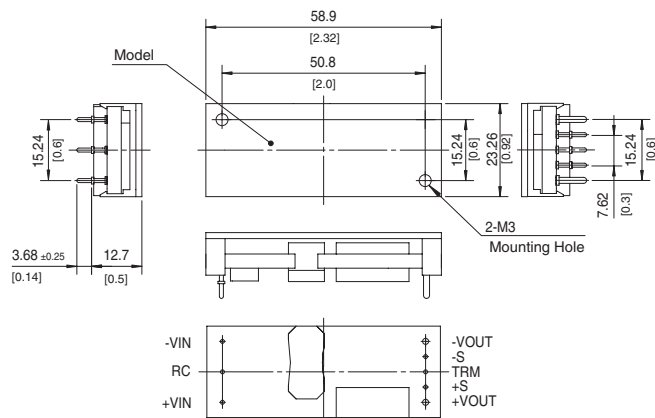

3. Baseplate and case (option BC)

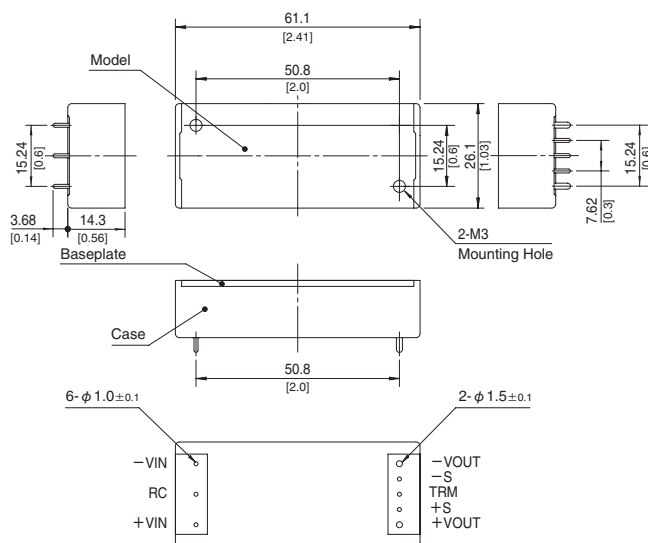

4. Spins type (option L5)

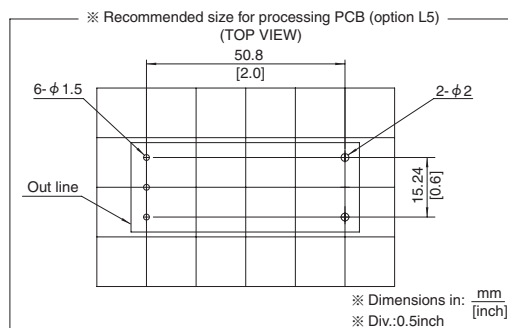
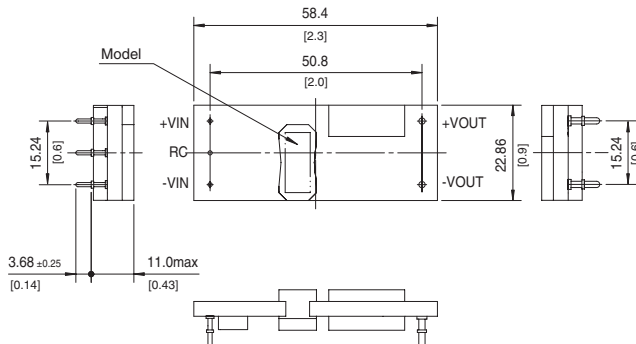

* Please contact us about external view of the PMBus interface (option I).

CHS400

CH S 400 48 12 - □

① ② ③ ④ ⑤ ⑥

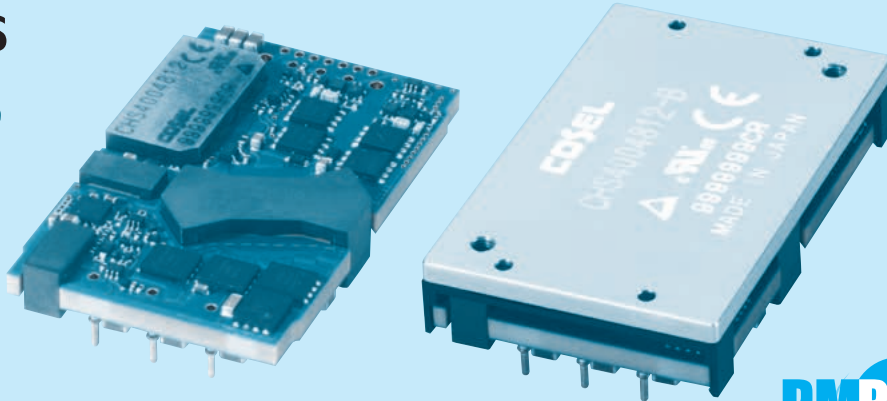

- ① Series name
- ② Single output
- ③ Output power
- ④ Input voltage
48:DC36 - 76V
- ⑤ Output voltage
10:10V
12:12V
12H:12V(High efficiency type)
- ⑥ Optional
R :with Remote ON/OFF
Positive logic control
U :Shut down in protection
circuit working
B :BasePlate option with
Mounting hole M3
P :Parallel operation (5Pins
:without +S,-S and TRM)
L2:Pin length 5.3mm
L5:5pins type (+S,-S,TRM
less)
I :with the PMBus interface
(Only CHS4004812)

MODEL	CHS4004810	CHS4004812	CHS4004812H
MAX OUTPUT WATTAGE[W]	400.0	396.0	396.0
DC OUTPUT	10V 40A	12V 33A	12V 33A

SPECIFICATIONS

	MODEL	CHS4004810	CHS4004812	CHS4004812H	
INPUT	VOLTAGE[V]	DC36 - 76			
	CURRENT[A]	*1 8.82typ	8.68typ	8.64typ	
	EFFICIENCY[%]	*1 94.5typ	95typ	95.5typ	
OUTPUT	VOLTAGE[V]	10			
	CURRENT[A]	40			
	LINE REGULATION[mV]	*7 ±10max	±12max	±12max	
	LOAD REGULATION[mV]	*6 *7 ±10max	±12max	±12max	
	RIPPLE	[mVrms]	*2 60max	60max	60max
		[mVp-p]	*2 160max	180max	180max
	RIPPLE NOISE[mVp-p]	*2 180max	200max	200max	
	TEMPERATURE REGULATION[mV]	200max			
	DRIFT[mV]	*3 30max	40max	40max	
	START-UP TIME[ms]	50max (DCIN 48V, Io=100%)			
OUTPUT VOLTAGE ADJUSTMENT RANGE[V]	*4 Fixed (TRM pin open), adjustable by external resistor (N/A : parallel operation)				
PROTECTION CIRCUIT AND OTHERS	OVERCURRENT PROTECTION	Works over 105% of rating (Auto restart)			
	OVERVOLTAGE PROTECTION	115% - 135% (Auto restart)			
	REMOTE SENSING	Provided (N/A : parallel operation)			
ISOLATION	REMOTE ON/OFF	Provided (Negative Logic L : ON, H :OFF)			
	INPUT-OUTPUT	DC2,250V or AC1,000V 1minute, Cutoff current = 10mA, DC500V 50MΩ min (20±15°C)			
	INPUT-BASEPLATE	*5 DC2,250V or AC1,000V 1minute, Cutoff current = 10mA, DC500V 50MΩ min (20±15°C)			
ENVIRONMENT	OUTPUT-BASEPLATE	*5 AC500V 1minute, Cutoff current = 10mA, DC500V 50MΩ min (20±15°C)			
	OPERATING TEMP.,HUMID.AND ALTITUDE	-40 to +85°C, 20 - 95%RH (Non condensing) (Refer to DERATING CURVE), 5,000m (16,000 feet) max			
	STORAGE TEMP.,HUMID.AND ALTITUDE	-40 to +100°C, 20 - 95%RH (Non condensing), 9,000m (30,000 feet) max			
	VIBRATION	10 - 55Hz, 49.0m/s ² (5G), 3minutes period, 60minutes each along X, Y and Z axis			
SAFETY	IMPACT	196.1m/s ² (20G), 11ms, once each along X, Y and Z axis			
	AGENCY APPROVALS	UL60950-1, C-UL (CSA60950-1), EN60950			
OTHERS	CASE SIZE/WEIGHT	58.4×9.5×36.8mm [2.3×0.37×1.45 inches] (W×H×D) / 60g max			
	COOLING METHOD	58.9×12.7×37.3mm [2.32×0.5×1.47 inches] (W×H×D) / 90g max *5			
		Convection / Forced air / Conduction			

*1 At rated input (DC48V) and rated load. Ta=25°C, 2m/s.
 *2 Ripple and ripple noise is measured by using measuring board with ceramic capacitor 22 μF.
 *3 Drift is the change in DC output for an eight hour period after a half-hour warm-up at 25°C, with the input voltage held constant at the rated input/output.
 *4 Refer to the instruction manual for input voltage derating.
 *5 BasePlate Option.
 *6 Parallel operation Option is not included.
 *7 At input voltage DC36-76V(CHS4004810, CHS4004812), DC40-76V(CHS4004812H).

External view

1. DIP

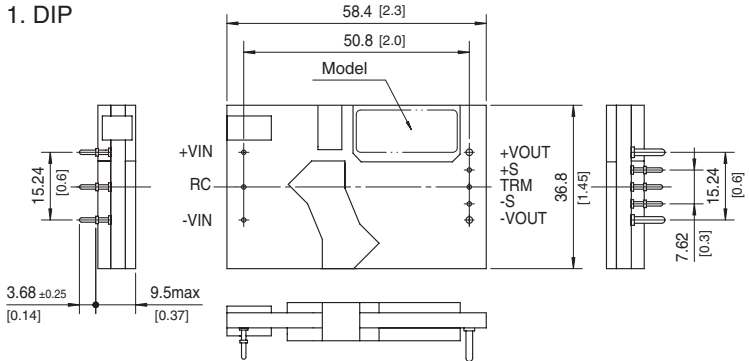

※ Tolerance: ±0.5 [±0.02]
 ※ Dimensions in mm, []=inches

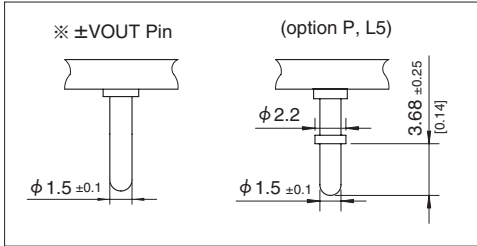

2. BasePlate (optionB)

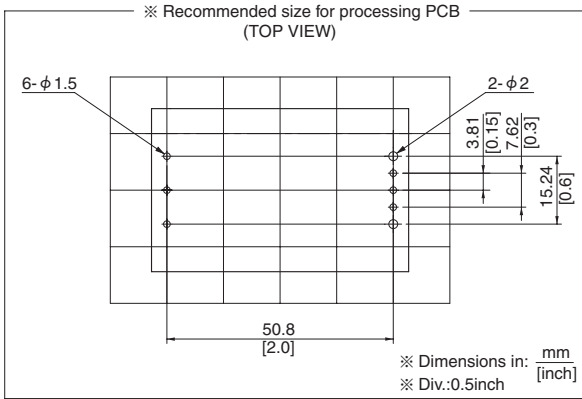
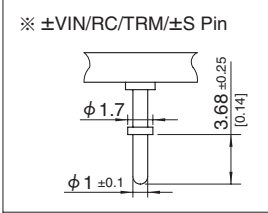
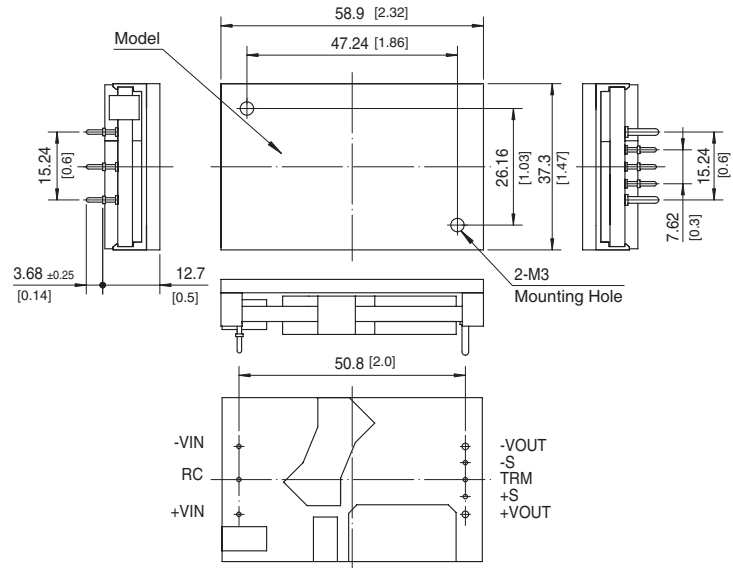

3. Parallel operation (option P)
 5pins type (option L5)

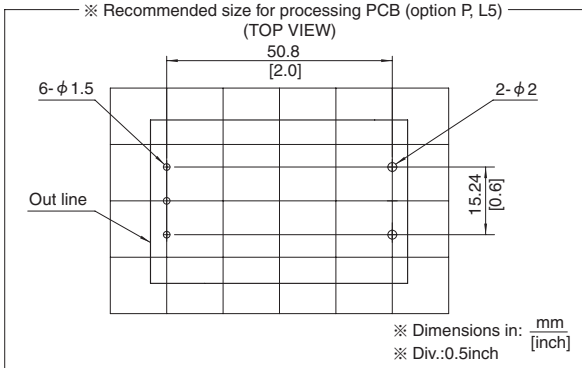
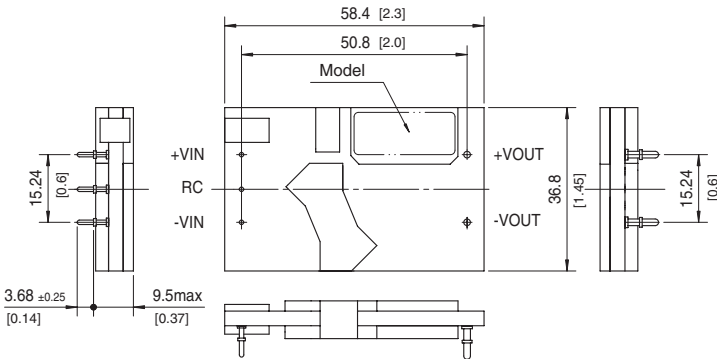

*Please contact us about external view of the PMBus interface (option I).

CHS500

CH S 500 48 12 - □

① ② ③ ④ ⑤ ⑥

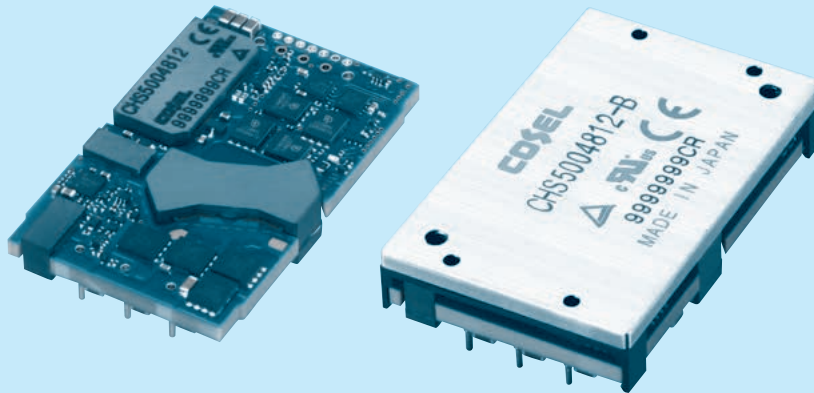
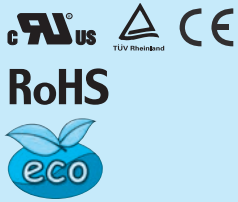

- ① Series name
- ② Single output
- ③ Output power
- ④ Input voltage
48:DC36 - 76V
- ⑤ Output voltage
12:12V
- ⑥ Optional
 - R :with Remote ON/OFF
Positive logic control
 - U :Shut down in protection
circuit working
 - B :BasePlate option with
Mounting hole M3
 - P :Parallel operation (5Pins
:without +S,-S and TRM)
 - L2:Pin length 5.3mm
 - L5:5pins type (+S,-S,TRM
less)

MODEL	CHS5004812
MAX OUTPUT WATTAGE[W]	504.0
DC OUTPUT	12V 42A

SPECIFICATIONS

	MODEL	CHS5004812	
INPUT	VOLTAGE[V]	DC36 - 76	
	CURRENT[A]	*1 11.06typ	
	EFFICIENCY[%]	*1 95typ	
OUTPUT	VOLTAGE[V]	12	
	CURRENT[A]	42	
	LINE REGULATION[mV]	±12max	
	LOAD REGULATION[mV]	*6 ±12max	
	RIPPLE	[mVrms] *2	60max
		[mVp-p] *2	180max
	RIPPLE NOISE[mVp-p]	*2 200max	
	TEMPERATURE REGULATION[mV]	240max	
	DRIFT[mV]	*3 40max	
	START-UP TIME[ms]	50max (DCIN 48V, Io=100%)	
OUTPUT VOLTAGE ADJUSTMENT RANGE[V]	*4 Fixed (TRM pin open), adjustable by external resistor (N/A : parallel operation) -10% / +10%		
OUTPUT VOLTAGE SETTING[V]	*1 *5 ±1.6%		
PROTECTION CIRCUIT AND OTHERS	OVERCURRENT PROTECTION	Works over 105% of rating (Auto restart)	
	OVERVOLTAGE PROTECTION	115% - 135% (Auto restart)	
	REMOTE SENSING	Provided (N/A : parallel operation)	
	REMOTE ON/OFF	Provided (Negative Logic L : ON, H :OFF)	
ISOLATION	INPUT-OUTPUT	DC2,250V or AC1,000V 1minute, Cutoff current = 10mA, DC500V 50MΩ min (20±15°C)	
	INPUT-BASEPLATE	*5 DC2,250V or AC1,000V 1minute, Cutoff current = 10mA, DC500V 50MΩ min (20±15°C)	
	OUTPUT-BASEPLATE	*5 AC500V 1minute, Cutoff current = 10mA, DC500V 50MΩ min (20±15°C)	
ENVIRONMENT	OPERATING TEMP.,HUMID.AND ALTITUDE	-40 to +85°C, 20 - 95%RH (Non condensing) (Refer to DERATING CURVE), 5,000m (16,000 feet) max	
	STORAGE TEMP.,HUMID.AND ALTITUDE	-40 to +100°C, 20 - 95%RH (Non condensing), 9,000m (30,000 feet) max	
	VIBRATION	10 - 55Hz, 49.0m/s ² (5G), 3minutes period, 60minutes each along X, Y and Z axis	
	IMPACT	196.1m/s ² (20G), 11ms, once each along X, Y and Z axis	
SAFETY	AGENCY APPROVALS	UL60950-1, C-UL (CSA60950-1), EN60950	
OTHERS	CASE SIZE/WEIGHT	58.4×9.5×36.8mm [2.3×0.37×1.45 inches] (W×H×D) / 60g max 58.9×12.7×37.3mm [2.32×0.5×1.47 inches] (W×H×D) / 90g max *5	
	COOLING METHOD	Convection / Forced air / Conduction	

*1 At rated input (DC48V) and rated load. Ta=25°C, 2m/s.
 *2 Ripple and ripple noise is measured by using measuring board with ceramic capacitor 22 μF.
 *3 Drift is the change in DC output for an eight hour period after a half-hour warm-up at 25°C, with the input voltage held constant at the rated input/output.
 *4 Refer to the instruction manual for input voltage derating.
 *5 BasePlate Option.
 *6 Parallel operation Option is not included.

External view

1. DIP

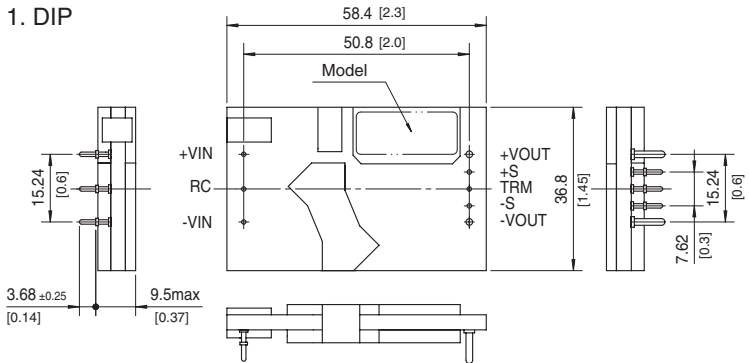

※ Tolerance: ±0.5 [±0.02]
※ Dimensions in mm, []=inches

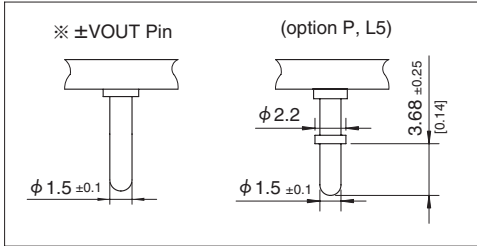

2. BasePlate (optionB)

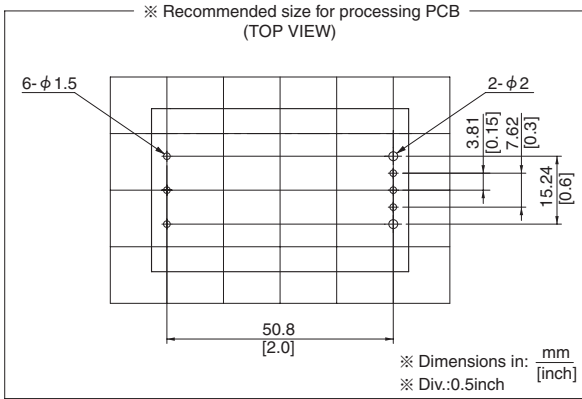
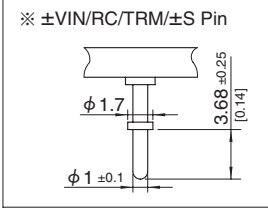
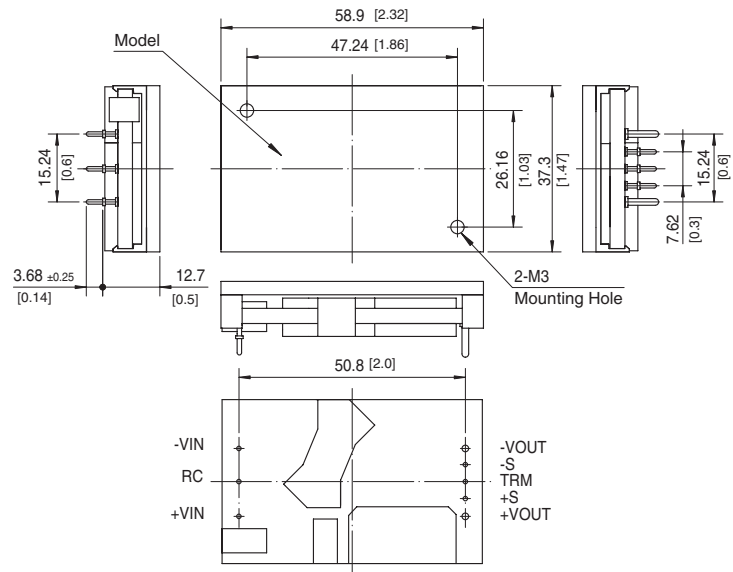

3. Parallel operation (option P)
5pins type (option L5)

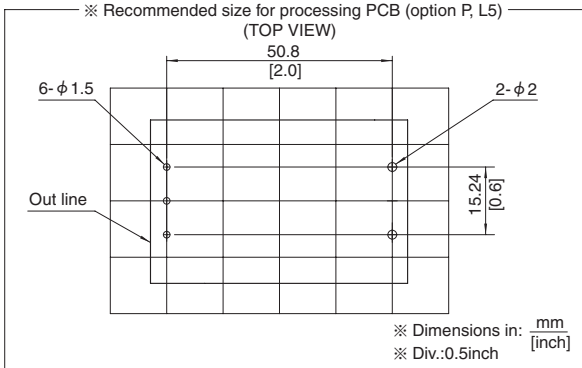
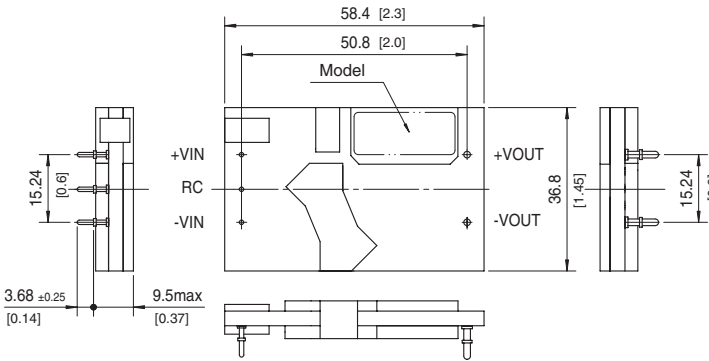

Mouser Electronics

Authorized Distributor

Click to View Pricing, Inventory, Delivery & Lifecycle Information:

Cosel:

[CHS2004812-R](#) [CHS804812](#) [CHS4004812](#) [CHS804812-U](#) [CHS804805-U](#) [CHS804805](#) [CHS200483R3-U](#)
[CHS80483R3-R](#) [CHS2004805-B](#) [CHS80483R3](#) [CHS804812-R](#) [CHS2004812-U](#) [CHS804805-R](#) [CHS80483R3-U](#)
[CHS2004805](#) [CHS200483R3-B](#) [CHS2004812-B](#) [CHS804812-S](#) [CHS200483R3](#) [CHS804805-S](#) [CHS2004805-U](#)
[CHS80483R3-S](#) [CHS2004805-R](#) [CHS2004812](#) [CHS200483R3-R](#) [CHS5004812](#) [CHS4004812H](#) [CHS60483R3](#)
[CHS604805](#) [CHS4004810](#) [CHS604812](#)



Компания «ЭлектроПласт» предлагает заключение долгосрочных отношений при поставках импортных электронных компонентов на взаимовыгодных условиях!

Наши преимущества:

- Оперативные поставки широкого спектра электронных компонентов отечественного и импортного производства напрямую от производителей и с крупнейших мировых складов;
- Поставка более 17-ти миллионов наименований электронных компонентов;
- Поставка сложных, дефицитных, либо снятых с производства позиций;
- Оперативные сроки поставки под заказ (от 5 рабочих дней);
- Экспресс доставка в любую точку России;
- Техническая поддержка проекта, помощь в подборе аналогов, поставка прототипов;
- Система менеджмента качества сертифицирована по Международному стандарту ISO 9001;
- Лицензия ФСБ на осуществление работ с использованием сведений, составляющих государственную тайну;
- Поставка специализированных компонентов (Xilinx, Altera, Analog Devices, Intersil, Interpoint, Microsemi, Aeroflex, Peregrine, Syfer, Eurofarad, Texas Instrument, Miteq, Cobham, E2V, MA-COM, Hittite, Mini-Circuits, General Dynamics и др.);

Помимо этого, одним из направлений компании «ЭлектроПласт» является направление «Источники питания». Мы предлагаем Вам помощь Конструкторского отдела:

- Подбор оптимального решения, техническое обоснование при выборе компонента;
- Подбор аналогов;
- Консультации по применению компонента;
- Поставка образцов и прототипов;
- Техническая поддержка проекта;
- Защита от снятия компонента с производства.



Как с нами связаться

Телефон: 8 (812) 309 58 32 (многоканальный)

Факс: 8 (812) 320-02-42

Электронная почта: org@eplast1.ru

Адрес: 198099, г. Санкт-Петербург, ул. Калинина, дом 2, корпус 4, литера А.