

THIS DRAWING IS UNPUBLISHED.

RELEASED FOR PUBLICATION

REVISIONS

© COPYRIGHT - TE Connectivity Ltd.

ALL RIGHTS RESERVED.

P	LTR	DESCRIPTION	DATE	DWN	APVD
	B	REVISED PER ECR-19-004770	10APR2019	SR	DD

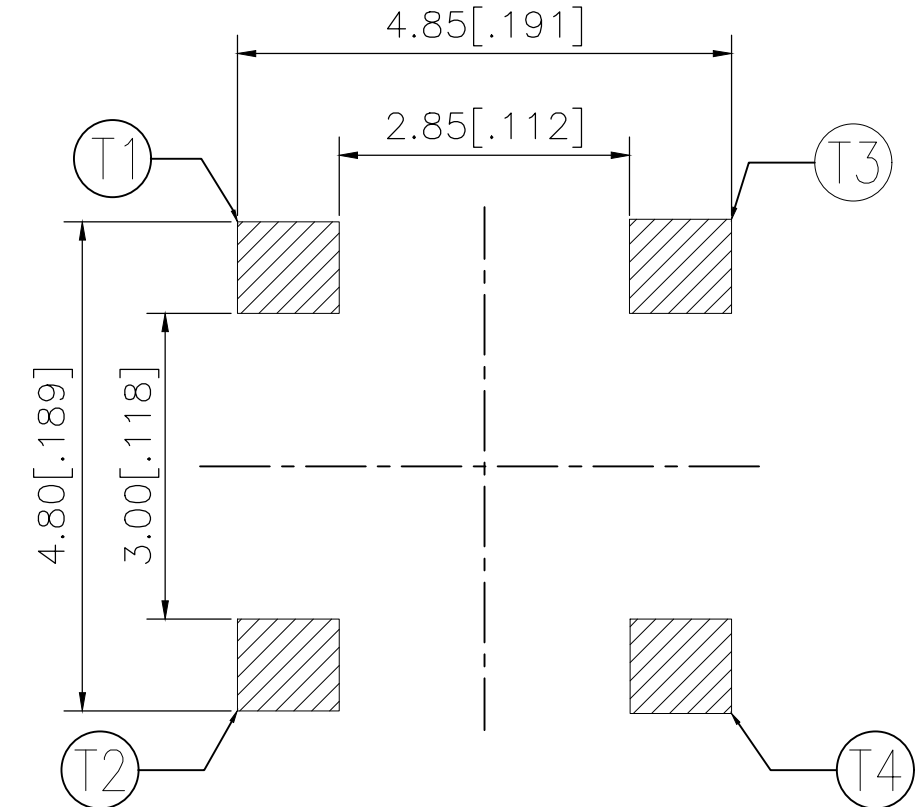
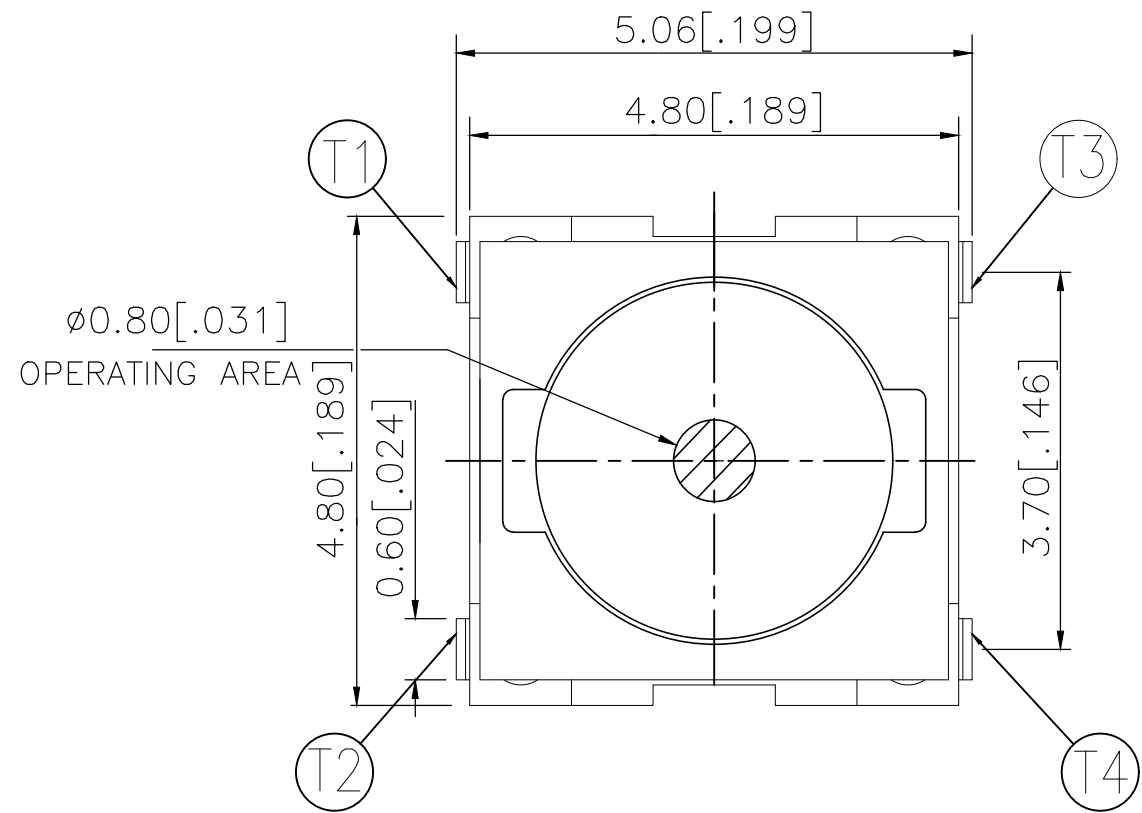

P.C.B. LAYOUT

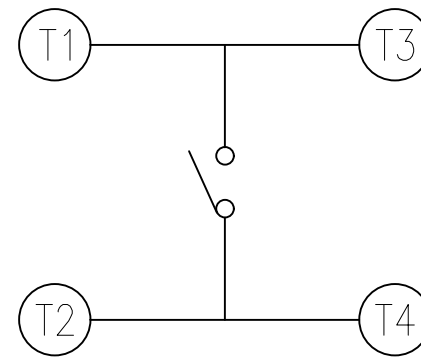
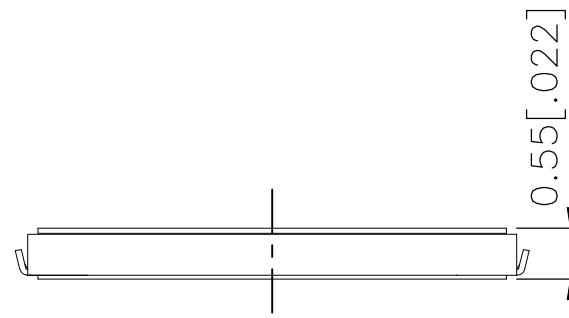

CIRCUIT DIAGRAM

360±60	MCSLPT4848C5DTR	2337233-5
260±50	MCSLPT4848C4DTR	2337233-4
200±50	MCSLPT4848C3DTR	2337233-3
160±50	MCSLPT4848C2DTR	2337233-2
100±50	MCSLPT4848C1DTR	2337233-1
ACTUATION FORCE (gf)	SMART PART NUMBER	PART NUMBER

THIS DRAWING IS A CONTROLLED DOCUMENT.

DWN GANESH C M 03JUL2018

DIMENSIONS: mm [INCHES]

TOLERANCES UNLESS OTHERWISE SPECIFIED:

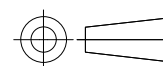

- 0 PLC ± -
- 1 PLC ± -
- 2 PLC ± 0.2 [.008]
- 3 PLC ± -
- 4 PLC ± -
- ANGLES ± -

MATERIAL

FINISH

CHK ALEXANDER SHARPE 03JUL2018

APVD ALEXANDER SHARPE 03JUL2018

PRODUCT SPEC

APPLICATION SPEC

WEIGHT

NAME  
**STE** TE Connectivity Ltd.  
 SWITCH, TACTILE, LOW-PROFILE, MICRO-MINI,  
 4.8 x 4.8 x 0.55, J BEND, 3.70 PITCH

SIZE	CAGE CODE	DRAWING NO	RESTRICTED TO
A3	00779	C-2337233	-

CUSTOMER DRAWING

SCALE NTS SHEET 1 of 3 REV B

THIS DRAWING IS UNPUBLISHED.

RELEASED FOR PUBLICATION

© COPYRIGHT - TE Connectivity Ltd.

ALL RIGHTS RESERVED.

REVISIONS

P	LTR	DESCRIPTION	DATE	DWN	APVD
-	-	SEE SHEET 1	-	-	-

NOTES:

1. MATERIALS:

TERMINAL: COPPER ALLOY, SILVER OVER NICKEL FINISH  
 BASE: THERMOPLASTIC, BLACK  
 TAPE: POLYIMIDE  
 CONTACT: STAINLESS STEEL, SILVER OVER NICKEL FINISH

2. COMPLIANCE:

ALL MATERIALS AND FINISHES SHALL COMPLY WITH  
 EU DIRECTIVE 2002/95/EC OF 27JAN2003(RoHS)

3. SPECIFICATIONS:

RATING: 50 mA, 12V DC  
 CONTACT RESISTANCE: 100mΩ MAXIMUM (INITIAL)  
 INSULATION RESISTANCE: 100MΩ MINIMUM (INITIAL)  
 DIELECTRIC STRENGTH: 100 V AC, 1 MINUTE  
 OPERATING LIFE: 2337233-1 (100gf) = 1,000,000 CYCLES WITH LOAD  
                   2337233-2 (160gf) = 1,000,000 CYCLES WITH LOAD  
                   2337233-3 (200gf) = 500,000 CYCLES WITH LOAD  
                   2337233-4 (260gf) = 500,000 CYCLES WITH LOAD  
                   2337233-5 (360gf) = 200,000 CYCLES WITH LOAD

TRAVEL: 0.2±0.1 [.008±.004]

ACTUATION FORCE: 2337233-1 = 100±50gf  
                   2337233-2 = 160±50gf  
                   2337233-3 = 200±50gf  
                   2337233-4 = 260±50gf  
                   2337233-5 = 360±60gf

OPERATING TEMPERATURE: -30° TO 80°C

STORAGE TEMPERATURE: -40° TO 85°C

4. SOLDER CONDITIONS :

SMT:

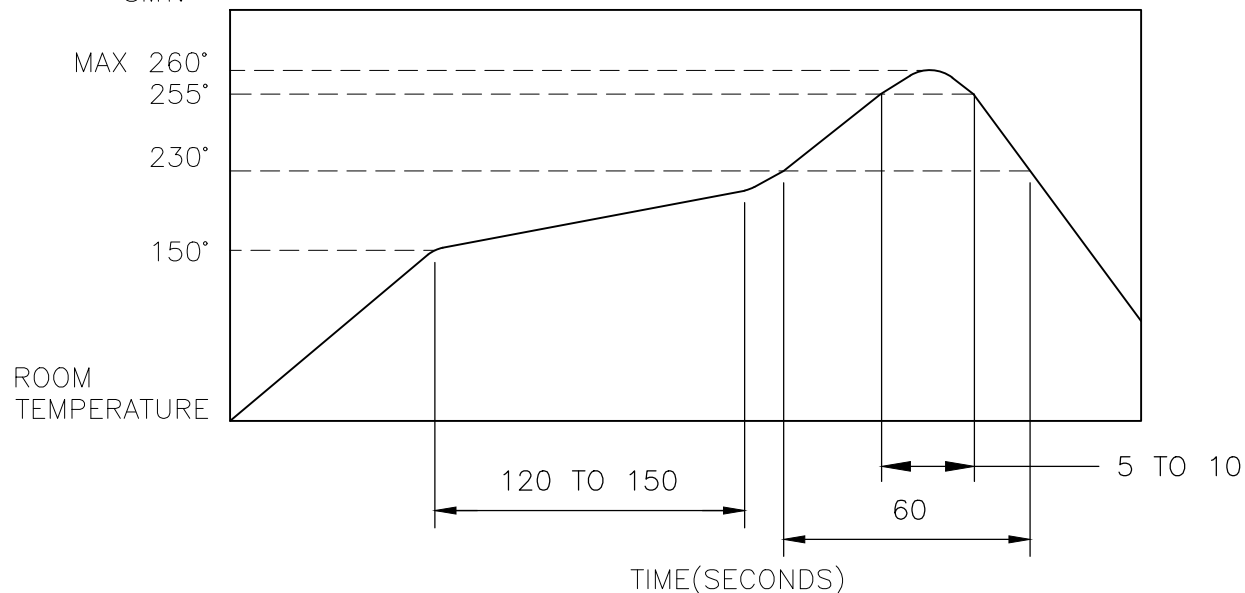

THE CONDITON NOTED ABOVE IS THE TEMPERATURE OF THE COPPER FOIL ON THE SURFACE OF THE PCB. THERE ARE CASES WHERE THE TEMPERATURE OF THE BOARD GREATLY DIFFERS FROM THE SURFACE OF THE SWITCH. DO NOT ALLOW THE SURFACE TEMPERATURE OF THE SWITCH TO EXCEED 260°C.

MANUAL SOLDERING:

SOLDERING TEMPERATURE	350°C MAXIMUM
CONTINUOUS SOLDERING TIME	5 SECONDS MAXIMUM

HANDLING PRECAUTIONS:

- CARE SHOULD BE EXERCISED SO THAT FLUX FROM THE TOP SURFACE OF THE PRINTED CIRCUIT BOARD DOES NOT ADHERE TO THE SWITCH.
- DO NOT WASH THE SWITCH

5. OPERATING PRECAUTIONS:

- DO NOT ACTUATE THE SWITCH WITH EXCESSIVE FORCE
- DISCONTINUE FORCE AFTER THE SWITCH HAS BEEN ACTUATED SO AS TO AVOID DEFORMATION OF THE COMPONENTS OF THE SWITCH. DEFORMATION OF THE COMPONENTS MAY CAUSE THE SWITCH TO MALFUNCTION.
- ALIGN THE PLUNGER WITH THE SWITCH TO INSURE PROPER OPERATION

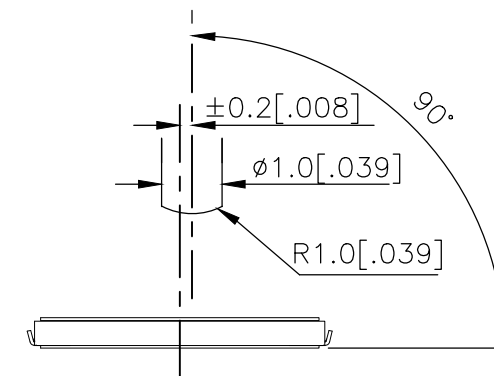

THIS DRAWING IS A CONTROLLED DOCUMENT.		DWN	GANESH C M		03JUL2018	TE Connectivity Ltd.					
DIMENSIONS: mm [INCHES]		CHK	ALEXANDER SHARPE		03JUL2018						
TOLERANCES UNLESS OTHERWISE SPECIFIED:		APVD	ALEXANDER SHARPE		03JUL2018	NAME					
0 PLC ± - 1 PLC ± - 2 PLC ± 0.2 [.008] 3 PLC ± - 4 PLC ± - ANGLES ± -		PRODUCT SPEC		-		SWITCH, TACTILE, LOW-PROFILE, MICRO-MINI, 4.8 x 4.8 x 0.55, J BEND, 3.70 PITCH					
MATERIAL		APPLICATION SPEC		-		SIZE	CAGE CODE	DRAWING NO	RESTRICTED TO		
FINISH		WEIGHT		-		A3	00779	C=2337233	-		
CUSTOMER DRAWING						SCALE	NTS	SHEET	2 OF 3	REV	B

THIS DRAWING IS UNPUBLISHED.

RELEASED FOR PUBLICATION

REVISIONS

© COPYRIGHT - TE Connectivity Ltd.

ALL RIGHTS RESERVED.

P	LTR	DESCRIPTION	DATE	DWN	APVD
-	-	SEE SHEET 1	-	-	-

THE DIMENSIONS OF CARRIER TAPE AND REEL

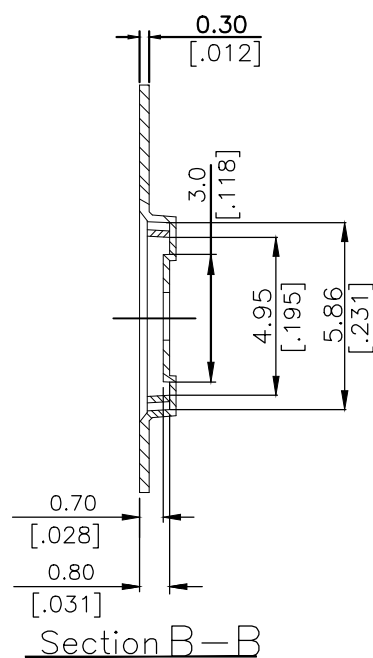
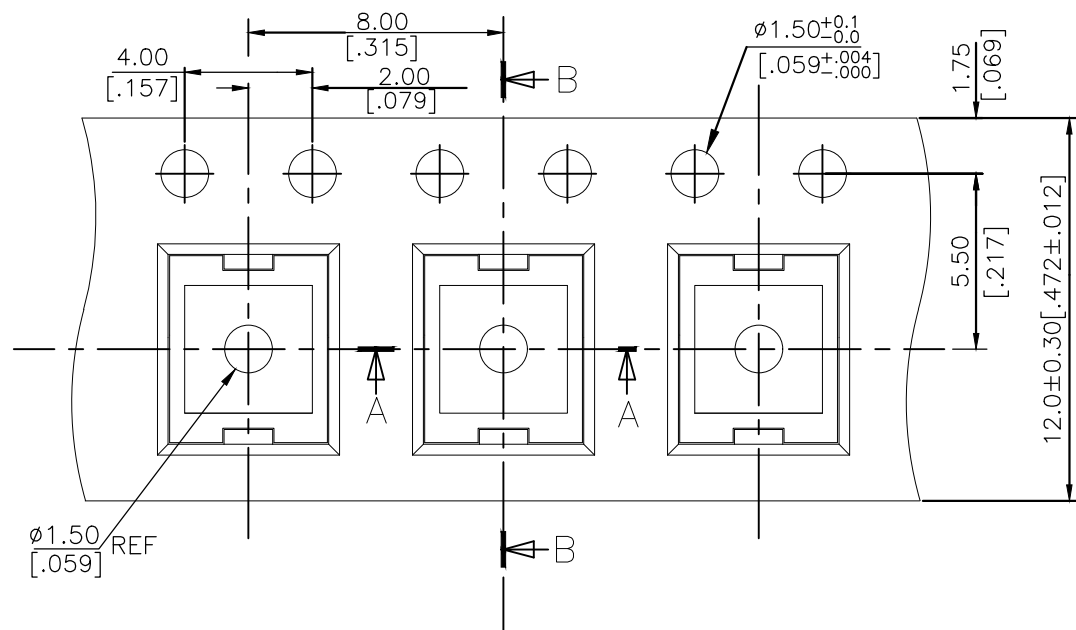

ORIENTATION OF PILOT HOLES

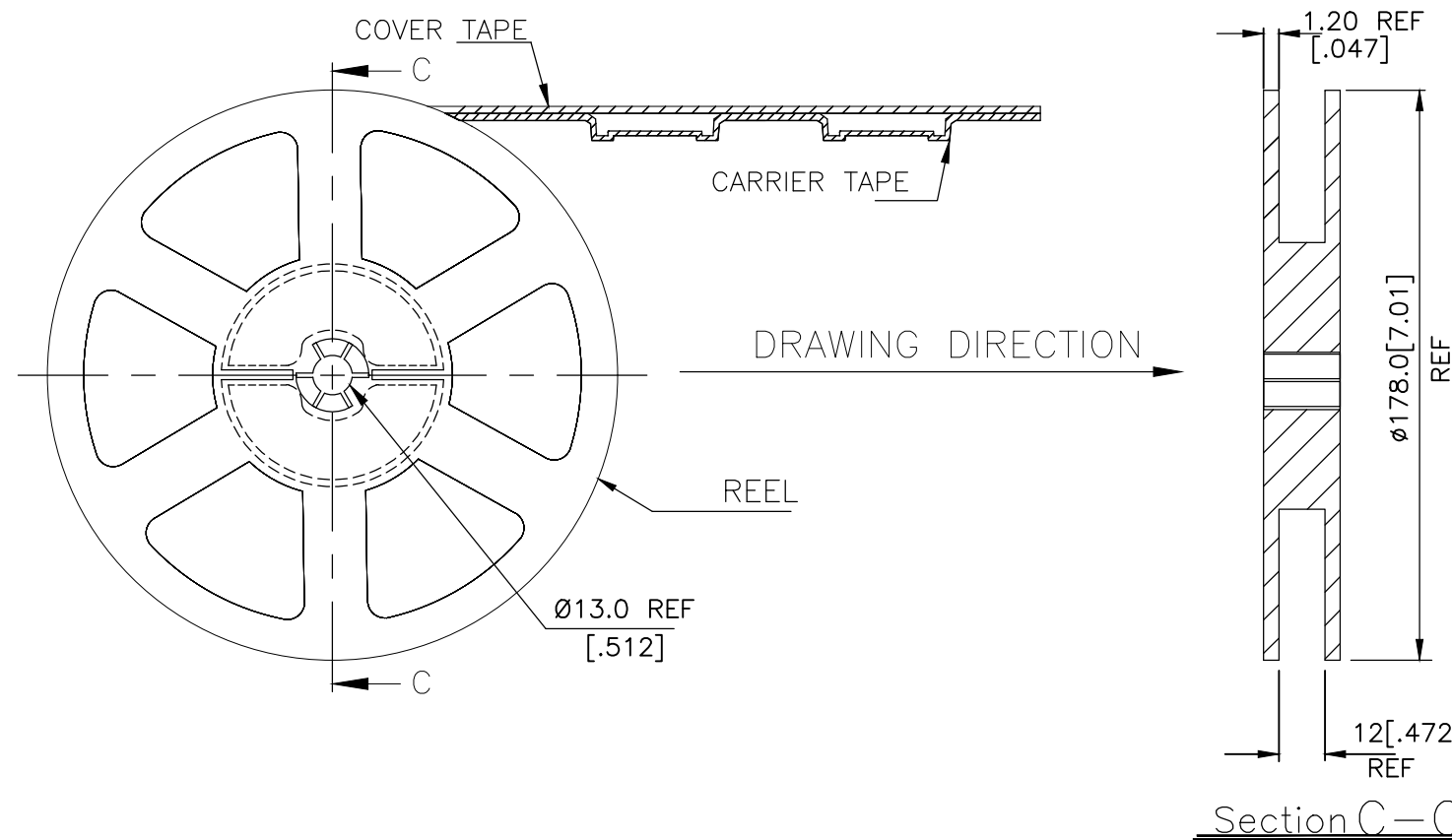
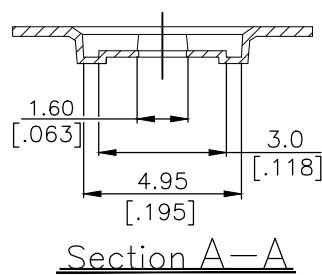
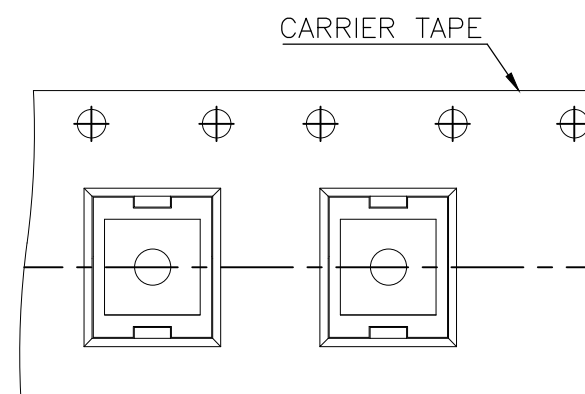

6. PACKAGING:

1. THE TAPE AND REEL ARE SHOWN FOR CUSTOMER APPLICATION REFERENCE. PACKAGING NOTES 3 AND 4 ARE REQUIRED BUT NOT ILLUSTRATED.
2. 2,500 SWITCHES PER REEL.
3. THE REEL, DESICCANT POUCH AND HUMIDITY CARD ARE SEALED IN A MOISTURE BARRIER BAG PER THE CURRENT REVISION OF IPC/JEDEC J-STD-033, MSL 2A REQUIREMENTS.
4. THE MOISTURE BARRIER BAG IS LABELED PER THE CURRENT REVISION OF IPC/JEDEC J-STD-033, MSL 2A REQUIREMENTS.

THIS DRAWING IS A CONTROLLED DOCUMENT.		DWN GANESH C M 03JUL2018	TE Connectivity Ltd.														
DIMENSIONS: mm [INCHES]		CHK ALEXANDER SHARPE 03JUL2018				NAME											
TOLERANCES UNLESS OTHERWISE SPECIFIED:		APVD ALEXANDER SHARPE 03JUL2018	SWITCH, TACTILE, LOW-PROFILE, MICRO-MINI, 4.8 x 4.8 x 0.55, J BEND, 3.70 PITCH														
<table border="0"> <tr><td>0 PLC</td><td>± -</td></tr> <tr><td>1 PLC</td><td>± -</td></tr> <tr><td>2 PLC</td><td>± 0.2 [.008]</td></tr> <tr><td>3 PLC</td><td>± -</td></tr> <tr><td>4 PLC</td><td>± -</td></tr> <tr><td>ANGLES</td><td>± -</td></tr> </table>		0 PLC	± -	1 PLC	± -	2 PLC	± 0.2 [.008]	3 PLC	± -	4 PLC	± -	ANGLES	± -	PRODUCT SPEC	SIZE CAGE CODE DRAWING NO RESTRICTED TO		
0 PLC	± -																
1 PLC	± -																
2 PLC	± 0.2 [.008]																
3 PLC	± -																
4 PLC	± -																
ANGLES	± -																
MATERIAL		APPLICATION SPEC	A3 00779 C-2337233														
FINISH		WEIGHT	CUSTOMER DRAWING SCALE NTS SHEET 3 OF 3 REV B														



Компания «ЭлектроПласт» предлагает заключение долгосрочных отношений при поставках импортных электронных компонентов на взаимовыгодных условиях!

Наши преимущества:

- Оперативные поставки широкого спектра электронных компонентов отечественного и импортного производства напрямую от производителей и с крупнейших мировых складов;
- Поставка более 17-ти миллионов наименований электронных компонентов;
- Поставка сложных, дефицитных, либо снятых с производства позиций;
- Оперативные сроки поставки под заказ (от 5 рабочих дней);
- Экспресс доставка в любую точку России;
- Техническая поддержка проекта, помощь в подборе аналогов, поставка прототипов;
- Система менеджмента качества сертифицирована по Международному стандарту ISO 9001;
- Лицензия ФСБ на осуществление работ с использованием сведений, составляющих государственную тайну;
- Поставка специализированных компонентов (Xilinx, Altera, Analog Devices, Intersil, Interpoint, Microsemi, Aeroflex, Peregrine, Syfer, Eurofarad, Texas Instrument, Miteq, Cobham, E2V, MA-COM, Hittite, Mini-Circuits, General Dynamics и др.);

Помимо этого, одним из направлений компании «ЭлектроПласт» является направление «Источники питания». Мы предлагаем Вам помощь Конструкторского отдела:

- Подбор оптимального решения, техническое обоснование при выборе компонента;
- Подбор аналогов;
- Консультации по применению компонента;
- Поставка образцов и прототипов;
- Техническая поддержка проекта;
- Защита от снятия компонента с производства.



#### Как с нами связаться

**Телефон:** 8 (812) 309 58 32 (многоканальный)

**Факс:** 8 (812) 320-02-42

**Электронная почта:** [org@eplast1.ru](mailto:org@eplast1.ru)

**Адрес:** 198099, г. Санкт-Петербург, ул. Калинина, дом 2, корпус 4, литера А.