

## Low-Voltage Dual SPST Analog Switch

### DESCRIPTION

The DG9232, 9233 is a single-pole/single-throw monolithic CMOS analog device designed for high performance switching of analog signals. Combining low power, high speed ( $t_{ON}$ : 35 ns,  $t_{OFF}$ : 20 ns), low on-resistance ( $R_{DS(on)}$ : 20  $\Omega$ ) and small physical size, the DG9232, 9233 is ideal for portable and battery powered applications requiring high performance and efficient use of board space.

The DG9232, 9233 is built on Vishay Siliconix's low voltage BCD-15 process. Minimum ESD protection, per method 3015.7 is 2000 V. An epitaxial layer prevents latchup. Break-before-make is guaranteed for DG9232, 9233.

Each switch conducts equally well in both directions when on, and blocks up to the power supply level when off.

### BENEFITS

- Reduced power consumption
- Simple logic interface
- High accuracy
- Reduce board space

### FEATURES

- Low voltage operation (+ 2.7 V to + 5 V)
- Low on-resistance -  $R_{DS(on)}$ : 20  $\Omega$
- Fast switching -  $t_{ON}$ : 35 ns,  $t_{OFF}$ : 20 ns
- Low leakage -  $I_{COM(on)}$ : 200 pA max.
- Low charge injection -  $Q_{INJ}$ : 1 pC
- Low power consumption
- TTL/CMOS compatible
- ESD protection > 2000 V (method 3015.7)
- Available in MSOP-8 and SOIC-8
- **Compliant to RoHS Directive 2002/95/EC**

**RoHS\***  
 COMPLIANT

### APPLICATIONS

- Battery operated systems
- Portable test equipment
- Sample and hold circuits
- Cellular phones
- Communication systems
- Military radio
- PBX, PABX guidance and control systems

### FUNCTIONAL BLOCK DIAGRAM AND PIN CONFIGURATION

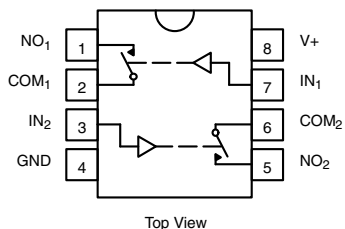
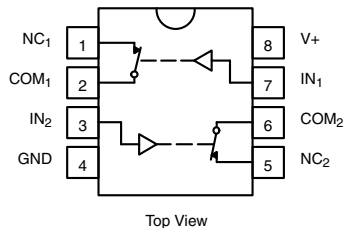
**TRUTH TABLE - DG9232**

Logic	Switch
0	On
1	Off

Logic "0"  $\leq$  0.8 V  
 Logic "1"  $\geq$  2.4 V

**TRUTH TABLE - DG9233**

Logic	Switch
0	Off
1	On

Logic "0"  $\leq$  0.8 V  
 Logic "1"  $\geq$  2.4 V

### ORDERING INFORMATION

Temp Range	Package	Part Number
- 40 °C to 85 °C	SOIC-8	DG9232DY
		DG9232DY-E3
		DG9232DY-T1
		DG9232DY-T1-E3
	MSOP-8	DG9233DY
		DG9233DY-E3
		DG9233DY-T1
		DG9233DY-T1-E3
		DG9232DQ-T1-E3
		DG9233DQ-T1-E3

\* Pb containing terminations are not RoHS compliant, exemptions may apply

ABSOLUTE MAXIMUM RATINGS			
Parameter		Limit	Unit
Reference V+ to GND		- 0.3 to + 13	V
IN, COM, NC, NO <sup>a</sup>		- 0.3 to (V+ + 0.3)	
Continuous Current (Any terminal)		± 20	mA
Peak Current (Pulsed at 1 ms, 10 % duty cycle)		± 40	
ESD (Method 3015.7)		> 2000	V
Storage Temperature	D suffix	- 65 to 125	°C
Power Dissipation (Packages) <sup>b</sup>	8-pin narrow body SOIC <sup>c</sup>	400	mW

Notes:

- a. Signals on NC, NO, or COM or IN exceeding V+ will be clamped by internal diodes. Limit forward diode current to maximum current ratings.
- b. All leads welded or soldered to PC board.
- c. Derate 6.5 mW/°C above 70 °C.

SPECIFICATIONS (V+ = 3 V)							
Parameter	Symbol	Test Conditions Otherwise Unless Specified V+ = 3 V, ± 10 %, V <sub>IN</sub> = 0.8 V or 2.4 V <sup>e</sup>	Temp. <sup>a</sup>	D Suffix - 40 °C to 85 °C			Unit
				Min. <sup>c</sup>	Typ. <sup>b</sup>	Max. <sup>c</sup>	
<b>Analog Switch</b>							
Analog Signal Range <sup>d</sup>	V <sub>ANALOG</sub>		Full	0		3	V
Drain-Source On-Resistance	R <sub>DS(on)</sub>	V <sub>NO</sub> or V <sub>NC</sub> = 1.5 V, V+ = 2.7 V I <sub>COM</sub> = 5 mA	Room Full		30	50 80	Ω
R <sub>DS(on)</sub> Match <sup>d</sup>	ΔR <sub>DS(on)</sub>	V <sub>NO</sub> or V <sub>NC</sub> = 1.5 V	Room		0.4	2	
R <sub>DS(on)</sub> Flatness <sup>d</sup>	R <sub>DS(on)</sub> Flatness	V <sub>NO</sub> or V <sub>NC</sub> = 1 and 2 V	Room		4	8	
NO or NC Off Leakage Current <sup>g</sup>	I <sub>NO/NC(off)</sub>	V <sub>NO</sub> or V <sub>NC</sub> = 1 V/2 V, V <sub>COM</sub> = 2 V/1 V	Room Full	- 100 - 5000	5	100 5000	pA
COM Off Leakage Current <sup>g</sup>	I <sub>COM(off)</sub>	V <sub>COM</sub> = 1 V/2 V, V <sub>NO</sub> or V <sub>NC</sub> = 2 V/1 V	Room Full	- 100 - 5000	5	100 5000	
Channel-On Leakage Current <sup>g</sup>	I <sub>COM(on)</sub>	V <sub>COM</sub> = V <sub>NO</sub> or V <sub>NC</sub> = 1 V/2 V	Room Full	- 200 - 10000	10	200 10000	
<b>Digital Control</b>							
Input Current	I <sub>INL</sub> or I <sub>INH</sub>		Full		1		μA
<b>Dynamic Characteristics</b>							
Turn-On Time	t <sub>ON</sub>	V <sub>NO</sub> or V <sub>NC</sub> = 1.5 V	Room Full		50	120 200	ns
Turn-Off Time	t <sub>OFF</sub>		Room Full		20	50 120	
Charge Injection <sup>d</sup>	Q <sub>INJ</sub>	C <sub>L</sub> = 1 nF, V <sub>GEN</sub> = 0 V, R <sub>GEN</sub> = 0 Ω	Room		1	5	pC
Off-Isolation	OIRR	R <sub>L</sub> = 50 Ω, C <sub>L</sub> = 5 pF, f = 1 MHz	Room		- 74		dB
Crosstalk	X <sub>TALK</sub>		Room		- 90		
NC and NO Capacitance	C <sub>S(off)</sub>	f = 1 MHz	Room		7		pF
Channel-On Capacitance	C <sub>COM(on)</sub>		Room		20		
COM-Off Capacitance	C <sub>COM(off)</sub>		Room		13		
<b>Power Supply</b>							
Positive Supply Range	V+			2.7		12	V
Power Supply Current	I+	V+ = 3.3 V, V <sub>IN</sub> = 0 or 3.3 V				1	μA

Notes:

- a. Room = 25 °C, Full = as determined by the operating suffix.
- b. Typical values are for design aid only, not guaranteed nor subject to production testing.
- c. The algebraic convention whereby the most negative value is a minimum and the most positive a maximum, is used in this datasheet.
- d. Guarantee by design, nor subjected to production test.
- e. V<sub>IN</sub> = input voltage to perform proper function.
- f. Difference of min and max values.
- g. Guaranteed by 5 V leakage tests, not production tested.



SPECIFICATIONS (V+ = 5 V)							
Parameter	Symbol	Test Conditions Otherwise Unless Specified V+ = 5 V, ± 10 %, VIN = 0.8 V or 2.4 V <sup>e</sup>	Temp. <sup>a</sup>	D Suffix - 40 °C to 85°C			Unit
				Min. <sup>c</sup>	Typ. <sup>b</sup>	Max. <sup>c</sup>	
<b>Analog Switch</b>							
Analog Signal Range <sup>d</sup>	V <sub>ANALOG</sub>		Full	0		5	V
Drain-Source On-Resistance	R <sub>DS(on)</sub>	V <sub>NO</sub> or V <sub>NC</sub> = 3.5 V, V+ = 4.5 V I <sub>COM</sub> = 5 mA	Room Full		20	30 50	Ω
R <sub>DS(on)</sub> Match <sup>d</sup>	ΔR <sub>DS(on)</sub>	V <sub>NO</sub> or V <sub>NC</sub> = 3.5 V	Room		0.4	2	
R <sub>DS(on)</sub> Flatness <sup>d</sup>	R <sub>DS(on)</sub> Flatness	V <sub>NO</sub> or V <sub>NC</sub> = 1, 2 and 3 V	Room		2	6	
NO or NC Off Leakage Current <sup>g</sup>	I <sub>NO/NC(off)</sub>	V <sub>NO</sub> or V <sub>NC</sub> = 1 V/4 V, V <sub>COM</sub> = 4 V/1 V	Room Full	- 100 - 5000	10	100 5000	pA
COM Off Leakage Current	I <sub>COM(off)</sub>	V <sub>COM</sub> = 1 V/4 V, V <sub>NO</sub> or V <sub>NC</sub> = 4 V/1 V	Room Full	- 100 - 5000	10	100 5000	
Channel-On Leakage Current	I <sub>COM(on)</sub>	V <sub>COM</sub> = V <sub>NO</sub> or V <sub>NC</sub> = 1 V/4 V	Room Full	- 200 - 10000		200 10000	
<b>Digital Control</b>							
Input Current	I <sub>INL</sub> or I <sub>INH</sub>		Full		1		μA
<b>Dynamic Characteristics</b>							
Turn-On Time	t <sub>ON</sub>	V <sub>NO</sub> or V <sub>NC</sub> = 3.0 V	Room Full		35	75 150	ns
Turn-Off Time	t <sub>OFF</sub>		Room Full		20	50 100	
Charge Injection <sup>d</sup>	Q <sub>INJ</sub>	C <sub>L</sub> = 1 nF, V <sub>GEN</sub> = 0 V, R <sub>GEN</sub> = 0 Ω	Room		2	5	pC
Off-Isolation	OIRR	R <sub>L</sub> = 50 Ω, C <sub>L</sub> = 5 pF, f = 1 MHz	Room		- 74		dB
Crosstalk	X <sub>TALK</sub>		Room		- 90		
NC and NO Capacitance	C <sub>(off)</sub>		f = 1 MHz	Room		7	
Channel-On Capacitance	C <sub>D(on)</sub>	Room			20		
COM-Off Capacitance	C <sub>D(off)</sub>	Room			13		
<b>Power Supply</b>							
Positive Supply Range	V+			2.7		12	V
Power Supply Current	I+	V+ = 5.5 V, V <sub>IN</sub> = 0 or 5.5 V				1	μA

Notes:

- a. Room = 25 °C, Full = as determined by the operating suffix.
- b. Typical values are for design aid only, not guaranteed nor subject to production testing.
- c. The algebraic convention whereby the most negative value is a minimum and the most positive a maximum, is used in this datasheet.
- d. Guarantee by design, nor subjected to production test.
- e. V<sub>IN</sub> = input voltage to perform proper function.
- f. Difference of min and max values.

Stresses beyond those listed under "Absolute Maximum Ratings" may cause permanent damage to the device. These are stress ratings only, and functional operation of the device at these or any other conditions beyond those indicated in the operational sections of the specifications is not implied. Exposure to absolute maximum rating conditions for extended periods may affect device reliability.

### TYPICAL CHARACTERISTICS $T_A = 25\text{ }^\circ\text{C}$ , unless otherwise noted

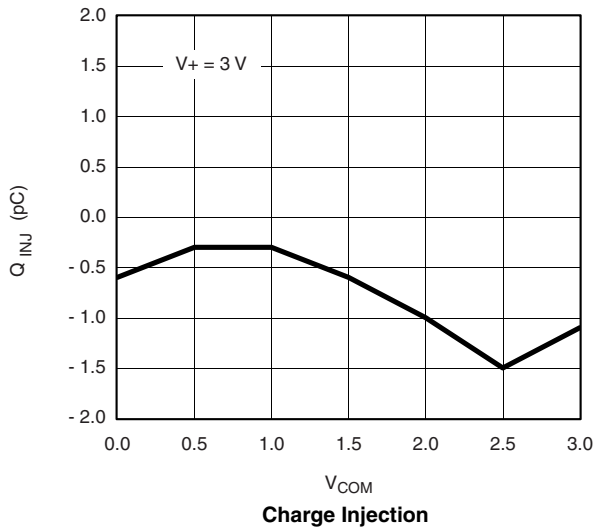

Charge Injection

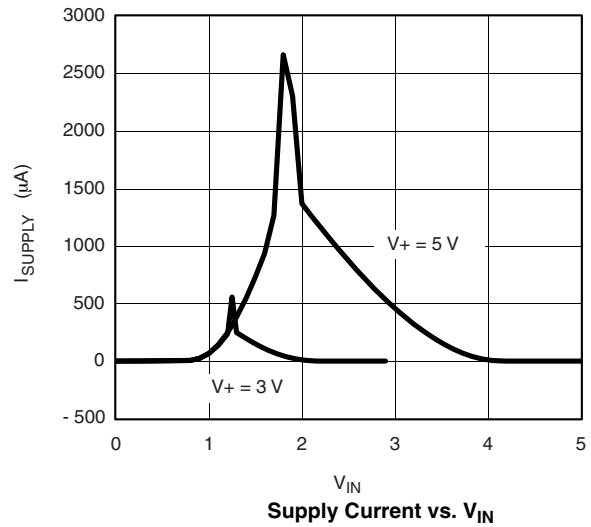

Supply Current vs.  $V_{IN}$

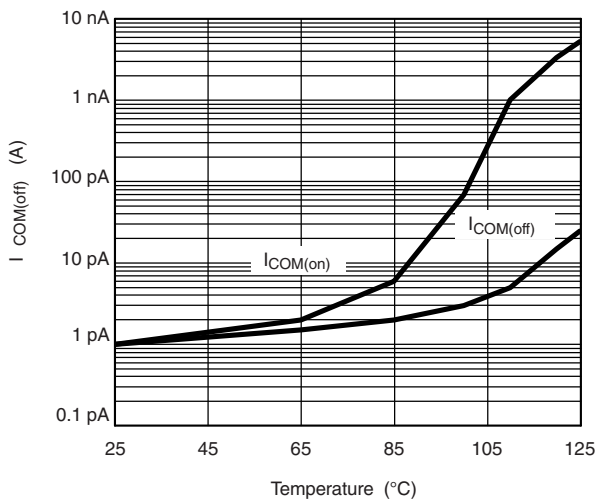

Leakage Current vs. Temperature

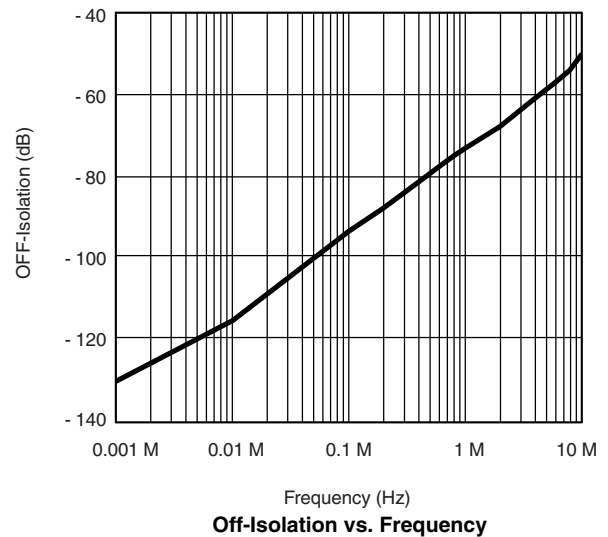

Off-Isolation vs. Frequency

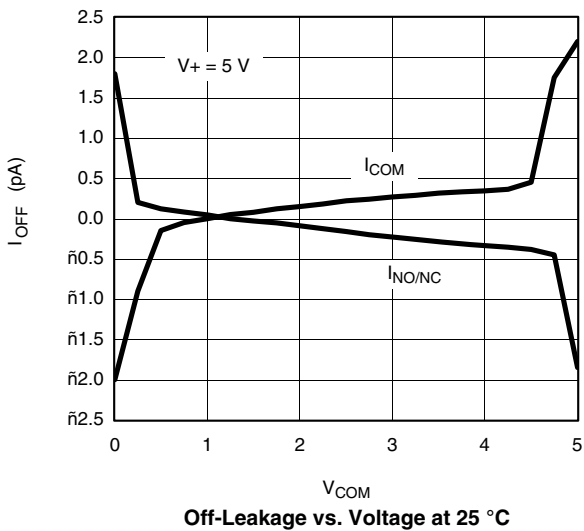

Off-Leakage vs. Voltage at  $25\text{ }^\circ\text{C}$

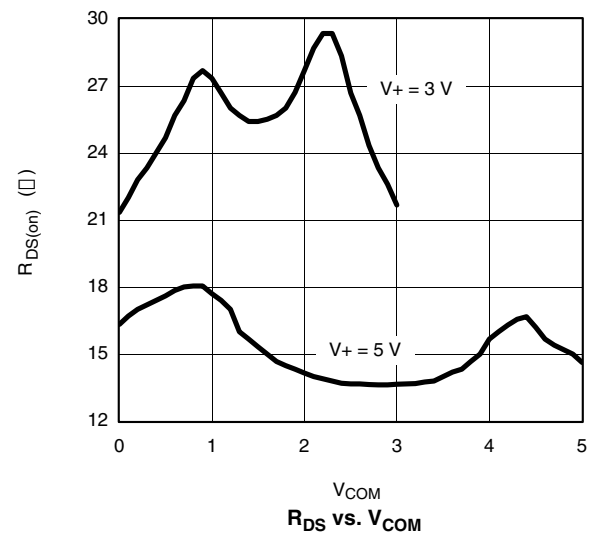

$R_{DS}$  vs.  $V_{COM}$

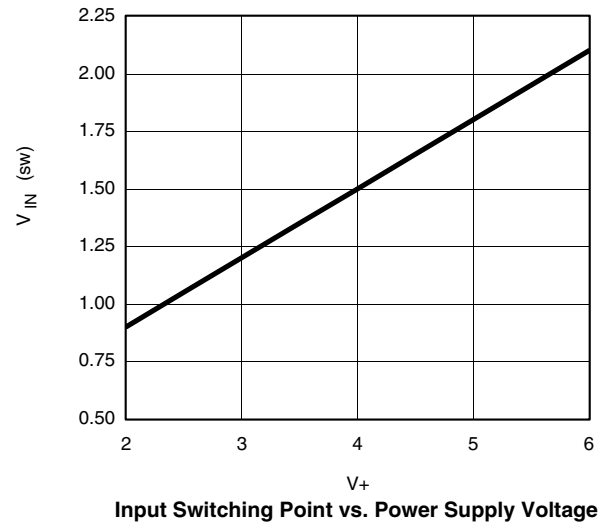
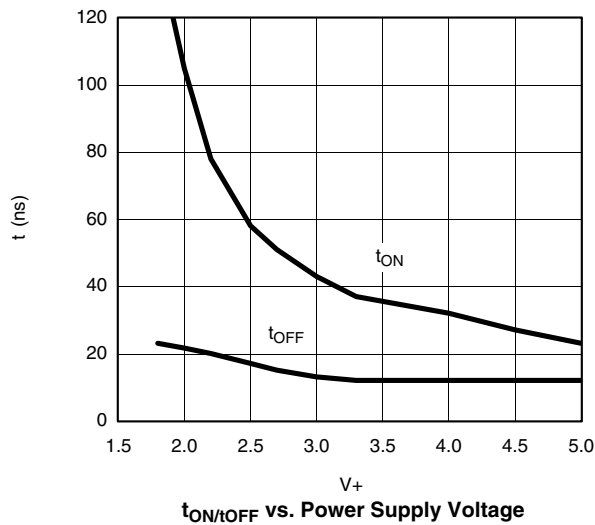
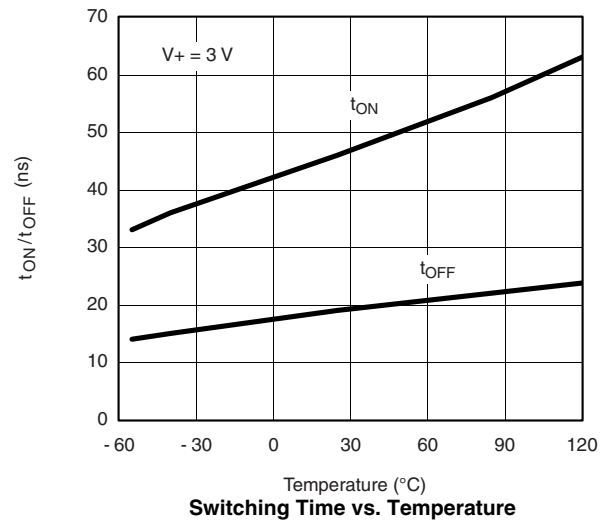
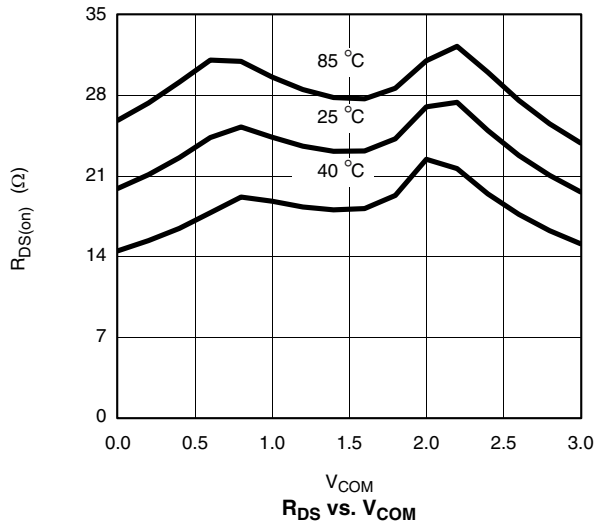
**TYPICAL CHARACTERISTICS**  $T_A = 25\text{ }^\circ\text{C}$ , unless otherwise noted

### TEST CIRCUITS

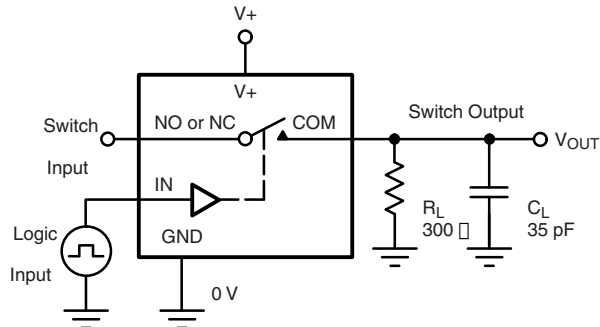

$C_L$  (includes fixture and stray capacitance)

$$V_{OUT} = V_{COM} \left( \frac{R_L}{R_L + R_{ON}} \right)$$

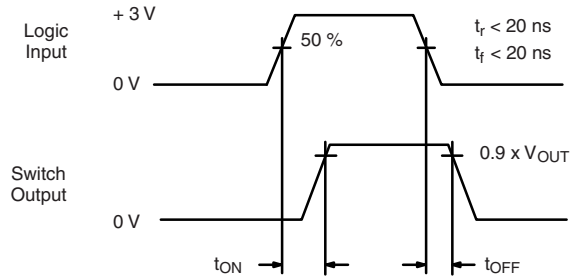

Logic "1" = Switch On  
Logic input waveforms inverted for switches that have the opposite logic sense.

Figure 1. Switching Time

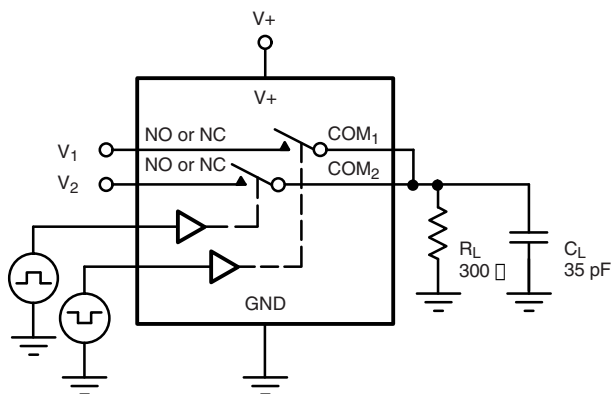

$C_L$  (includes fixture and stray capacitance)

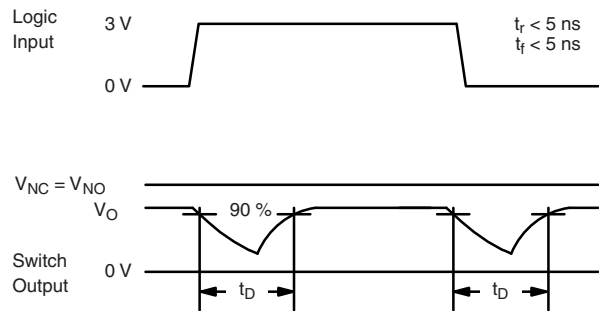
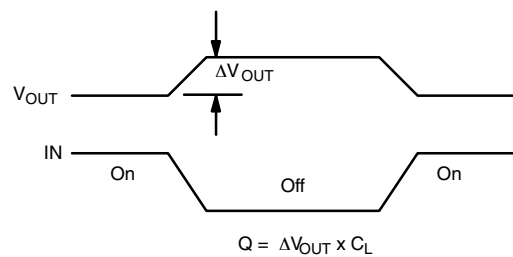
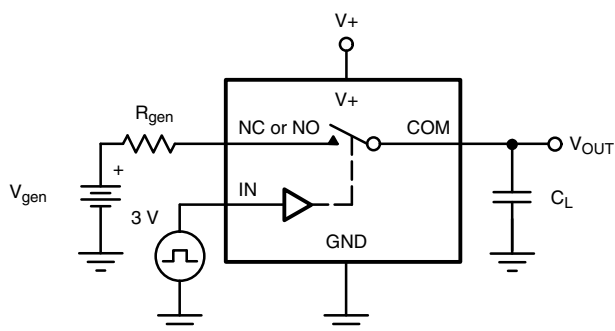

Figure 2. Break-Before-Make Interval



IN depends on switch configuration: input polarity determined by sense of switch.

Figure 3. Charge Injection

TEST CIRCUITS

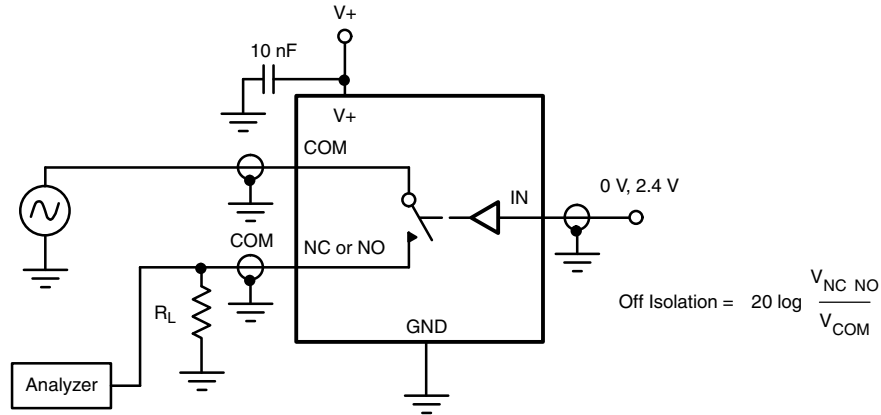

Figure 4. Off-Isolation

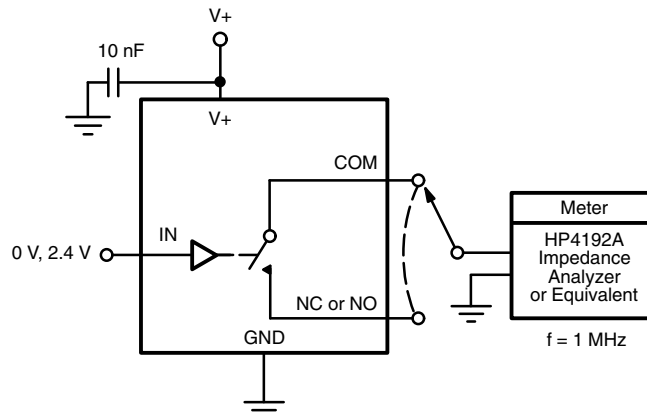

Figure 5. Channel Off/On Capacitance

Vishay Siliconix maintains worldwide manufacturing capability. Products may be manufactured at one of several qualified locations. Reliability data for Silicon Technology and Package Reliability represent a composite of all qualified locations. For related documents such as package/tape drawings, part marking, and reliability data, see <http://www.vishay.com/ppg?70837>.

## SOIC (NARROW): 8-LEAD

JEDEC Part Number: MS-012



DIM	MILLIMETERS		INCHES	
	Min	Max	Min	Max
A	1.35	1.75	0.053	0.069
A <sub>1</sub>	0.10	0.20	0.004	0.008
B	0.35	0.51	0.014	0.020
C	0.19	0.25	0.0075	0.010
D	4.80	5.00	0.189	0.196
E	3.80	4.00	0.150	0.157
e	1.27 BSC		0.050 BSC	
H	5.80	6.20	0.228	0.244
h	0.25	0.50	0.010	0.020
L	0.50	0.93	0.020	0.037
q	0°	8°	0°	8°
S	0.44	0.64	0.018	0.026
ECN: C-06527-Rev. I, 11-Sep-06				
DWG: 5498				





### MSOP: 8-LEADS

JEDEC Part Number: MO-187, (Variation AA and BA)

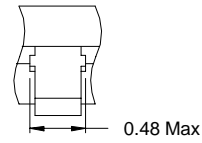
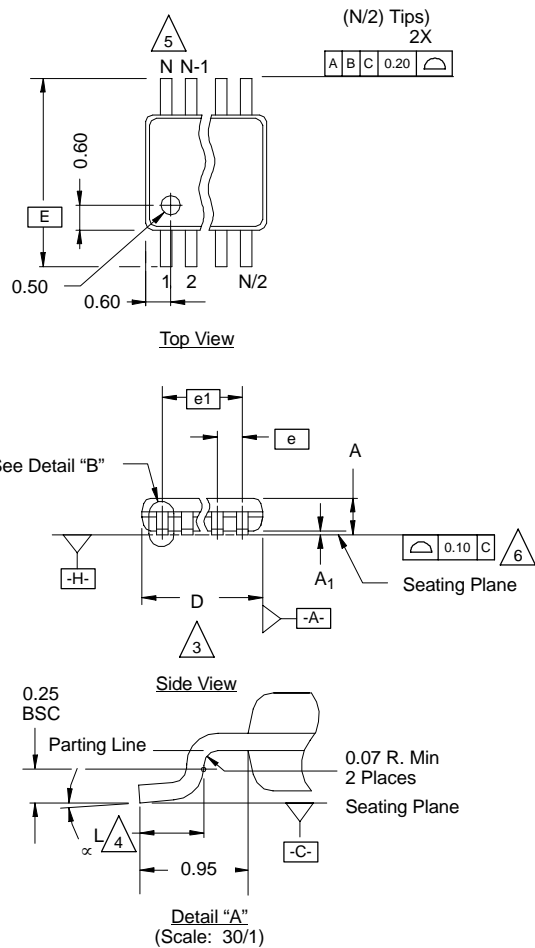

Detail "B"  
 (Scale: 30/1)  
 Dambar Protrusion

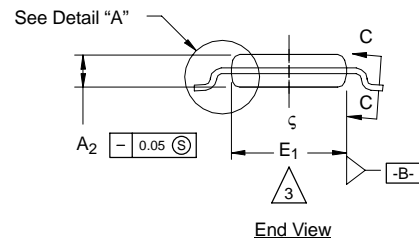
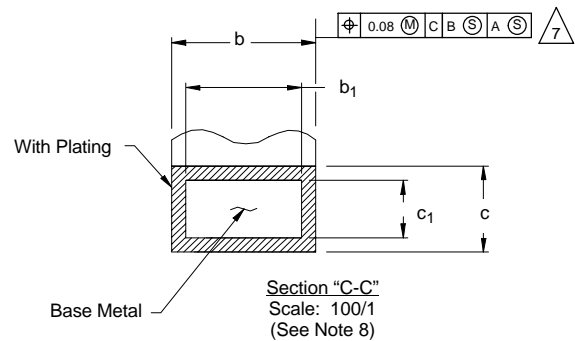

**NOTES:**

- Die thickness allowable is  $0.203 \pm 0.0127$ .
- Dimensioning and tolerances per ANSI.Y14.5M-1994.
- Dimensions "D" and "E<sub>1</sub>" do not include mold flash or protrusions, and are measured at Datum plane [-H-], mold flash or protrusions shall not exceed 0.15 mm per side.
- Dimension is the length of terminal for soldering to a substrate.
- Terminal positions are shown for reference only.
- Formed leads shall be planar with respect to one another within 0.10 mm at seating plane.
- The lead width dimension does not include Dambar protrusion. Allowable Dambar protrusion shall be 0.08 mm total in excess of the lead width dimension at maximum material condition. Dambar cannot be located on the lower radius or the lead foot. Minimum space between protrusions and an adjacent lead to be 0.14 mm. See detail "B" and Section "C-C".
- Section "C-C" to be determined at 0.10 mm to 0.25 mm from the lead tip.
- Controlling dimension: millimeters.
- This part is compliant with JEDEC registration MO-187, variation AA and BA.
- Datums [-A-] and [-B-] to be determined Datum plane [-H-].
- Exposed pad area in bottom side is the same as teh leadframe pad size.

**N = 8L**

Dim	MILLIMETERS			Note
	Min	Nom	Max	
<b>A</b>	-	-	1.10	
<b>A<sub>1</sub></b>	0.05	0.10	0.15	
<b>A<sub>2</sub></b>	0.75	0.85	0.95	
<b>b</b>	0.25	-	0.38	8
<b>b<sub>1</sub></b>	0.25	0.30	0.33	8
<b>c</b>	0.13	-	0.23	
<b>c<sub>1</sub></b>	0.13	0.15	0.18	
<b>D</b>	3.00 BSC			3
<b>E</b>	4.90 BSC			
<b>E<sub>1</sub></b>	2.90	3.00	3.10	3
<b>e</b>	0.65 BSC			
<b>e<sub>1</sub></b>	1.95 BSC			
<b>L</b>	0.40	0.55	0.70	4
<b>N</b>	8			5
$\alpha$	0°	4°	6°	

ECN: T-02080—Rev. C, 15-Jul-02  
 DWG: 5867



# Mounting LITTLE FOOT®, SO-8 Power MOSFETs

Wharton McDaniel

Surface-mounted LITTLE FOOT power MOSFETs use integrated circuit and small-signal packages which have been modified to provide the heat transfer capabilities required by power devices. Leadframe materials and design, molding compounds, and die attach materials have been changed, while the footprint of the packages remains the same.

See Application Note 826, *Recommended Minimum Pad Patterns With Outline Drawing Access for Vishay Siliconix MOSFETs*, (<http://www.vishay.com/ppg?72286>), for the basis of the pad design for a LITTLE FOOT SO-8 power MOSFET. In converting this recommended minimum pad to the pad set for a power MOSFET, designers must make two connections: an electrical connection and a thermal connection, to draw heat away from the package.

In the case of the SO-8 package, the thermal connections are very simple. Pins 5, 6, 7, and 8 are the drain of the MOSFET for a single MOSFET package and are connected together. In a dual package, pins 5 and 6 are one drain, and pins 7 and 8 are the other drain. For a small-signal device or integrated circuit, typical connections would be made with traces that are 0.020 inches wide. Since the drain pins serve the additional function of providing the thermal connection to the package, this level of connection is inadequate. The total cross section of the copper may be adequate to carry the current required for the application, but it presents a large thermal impedance. Also, heat spreads in a circular fashion from the heat source. In this case the drain pins are the heat sources when looking at heat spread on the PC board.

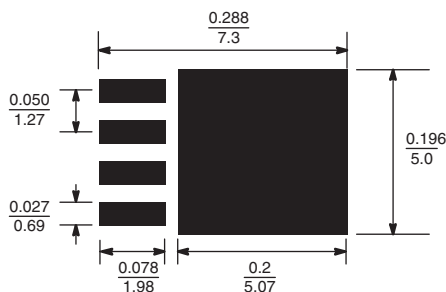

Figure 1. Single MOSFET SO-8 Pad Pattern With Copper Spreading

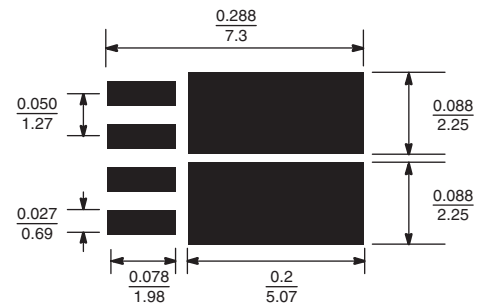

Figure 2. Dual MOSFET SO-8 Pad Pattern With Copper Spreading

The minimum recommended pad patterns for the single-MOSFET SO-8 with copper spreading (Figure 1) and dual-MOSFET SO-8 with copper spreading (Figure 2) show the starting point for utilizing the board area available for the heat-spreading copper. To create this pattern, a plane of copper overlies the drain pins. The copper plane connects the drain pins electrically, but more importantly provides planar copper to draw heat from the drain leads and start the process of spreading the heat so it can be dissipated into the ambient air. These patterns use all the available area underneath the body for this purpose.

Since surface-mounted packages are small, and reflow soldering is the most common way in which these are affixed to the PC board, “thermal” connections from the planar copper to the pads have not been used. Even if additional planar copper area is used, there should be no problems in the soldering process. The actual solder connections are defined by the solder mask openings. By combining the basic footprint with the copper plane on the drain pins, the solder mask generation occurs automatically.

A final item to keep in mind is the width of the power traces. The absolute minimum power trace width must be determined by the amount of current it has to carry. For thermal reasons, this minimum width should be at least 0.020 inches. The use of wide traces connected to the drain plane provides a low impedance path for heat to move away from the device.

## RECOMMENDED MINIMUM PADS FOR SO-8



Recommended Minimum Pads  
Dimensions in Inches/(mm)

[Return to Index](#)



## Disclaimer

ALL PRODUCT, PRODUCT SPECIFICATIONS AND DATA ARE SUBJECT TO CHANGE WITHOUT NOTICE TO IMPROVE RELIABILITY, FUNCTION OR DESIGN OR OTHERWISE.

Vishay Intertechnology, Inc., its affiliates, agents, and employees, and all persons acting on its or their behalf (collectively, "Vishay"), disclaim any and all liability for any errors, inaccuracies or incompleteness contained in any datasheet or in any other disclosure relating to any product.

Vishay makes no warranty, representation or guarantee regarding the suitability of the products for any particular purpose or the continuing production of any product. To the maximum extent permitted by applicable law, Vishay disclaims (i) any and all liability arising out of the application or use of any product, (ii) any and all liability, including without limitation special, consequential or incidental damages, and (iii) any and all implied warranties, including warranties of fitness for particular purpose, non-infringement and merchantability.

Statements regarding the suitability of products for certain types of applications are based on Vishay's knowledge of typical requirements that are often placed on Vishay products in generic applications. Such statements are not binding statements about the suitability of products for a particular application. It is the customer's responsibility to validate that a particular product with the properties described in the product specification is suitable for use in a particular application. Parameters provided in datasheets and/or specifications may vary in different applications and performance may vary over time. All operating parameters, including typical parameters, must be validated for each customer application by the customer's technical experts. Product specifications do not expand or otherwise modify Vishay's terms and conditions of purchase, including but not limited to the warranty expressed therein.

Except as expressly indicated in writing, Vishay products are not designed for use in medical, life-saving, or life-sustaining applications or for any other application in which the failure of the Vishay product could result in personal injury or death. Customers using or selling Vishay products not expressly indicated for use in such applications do so at their own risk. Please contact authorized Vishay personnel to obtain written terms and conditions regarding products designed for such applications.

No license, express or implied, by estoppel or otherwise, to any intellectual property rights is granted by this document or by any conduct of Vishay. Product names and markings noted herein may be trademarks of their respective owners.

## Material Category Policy

**Vishay Intertechnology, Inc. hereby certifies that all its products that are identified as RoHS-Compliant fulfill the definitions and restrictions defined under Directive 2011/65/EU of The European Parliament and of the Council of June 8, 2011 on the restriction of the use of certain hazardous substances in electrical and electronic equipment (EEE) - recast, unless otherwise specified as non-compliant.**

**Please note that some Vishay documentation may still make reference to RoHS Directive 2002/95/EC. We confirm that all the products identified as being compliant to Directive 2002/95/EC conform to Directive 2011/65/EU.**

**Vishay Intertechnology, Inc. hereby certifies that all its products that are identified as Halogen-Free follow Halogen-Free requirements as per JEDEC JS709A standards. Please note that some Vishay documentation may still make reference to the IEC 61249-2-21 definition. We confirm that all the products identified as being compliant to IEC 61249-2-21 conform to JEDEC JS709A standards.**



Компания «ЭлектроПласт» предлагает заключение долгосрочных отношений при поставках импортных электронных компонентов на взаимовыгодных условиях!

Наши преимущества:

- Оперативные поставки широкого спектра электронных компонентов отечественного и импортного производства напрямую от производителей и с крупнейших мировых складов;
- Поставка более 17-ти миллионов наименований электронных компонентов;
- Поставка сложных, дефицитных, либо снятых с производства позиций;
- Оперативные сроки поставки под заказ (от 5 рабочих дней);
- Экспресс доставка в любую точку России;
- Техническая поддержка проекта, помощь в подборе аналогов, поставка прототипов;
- Система менеджмента качества сертифицирована по Международному стандарту ISO 9001;
- Лицензия ФСБ на осуществление работ с использованием сведений, составляющих государственную тайну;
- Поставка специализированных компонентов (Xilinx, Altera, Analog Devices, Intersil, Interpoint, Microsemi, Aeroflex, Peregrine, Syfer, Eurofarad, Texas Instrument, Miteq, Cobham, E2V, MA-COM, Hittite, Mini-Circuits, General Dynamics и др.);

Помимо этого, одним из направлений компании «ЭлектроПласт» является направление «Источники питания». Мы предлагаем Вам помощь Конструкторского отдела:

- Подбор оптимального решения, техническое обоснование при выборе компонента;
- Подбор аналогов;
- Консультации по применению компонента;
- Поставка образцов и прототипов;
- Техническая поддержка проекта;
- Защита от снятия компонента с производства.



#### Как с нами связаться

**Телефон:** 8 (812) 309 58 32 (многоканальный)

**Факс:** 8 (812) 320-02-42

**Электронная почта:** [org@eplast1.ru](mailto:org@eplast1.ru)

**Адрес:** 198099, г. Санкт-Петербург, ул. Калинина, дом 2, корпус 4, литера А.