

DC Axial Fans

ebmpapst

Series 400, Type 412 40 x 40 x 20 mm

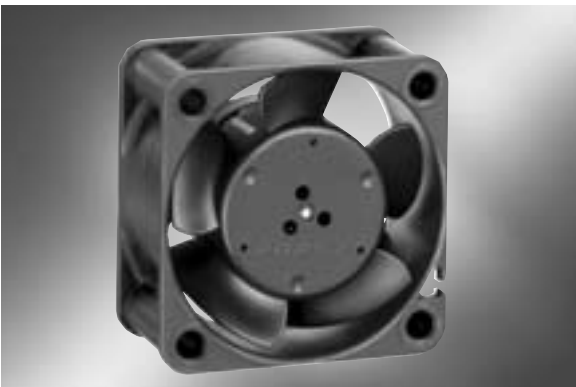

- DC fans with electronically commutated external rotor motor. Fully integrated commutation electronics.
- With electronic protection against reverse polarity. The fan only operates when the polarity is correct. Impedance-protected against blocking and overloading. Type 412 H and 414 H with electronic protection against blocking
- Fan of fibreglass reinforced plastic. PBT housing, PA impeller.
- Air exhaust over struts. Rotational direction CCW looking at rotor.
- Electrical connection via 2 leads AWG 28, TR 64. Stripped and tinned ends.
- Mass 27 g.

ebm-papst • St. Georgen

Nominal Data	Air Flow		Nominal Voltage	Voltage Range	Noise	Sinter-Sleeve Bearings Ball Bearings	Power Input	Nominal Speed	Temperature Range	Service Life L ₁₀		Curve
	m ³ /h	CFM								V DC	V DC	
405	10	5.9	5	4.5...5.5	18	3.8	■	0.9	6 000	-20...+70	50 000 / 20 000	1
412	10	5.9	12	10...14	18	3.8	□	0.9	6 000	-20...+70	50 000 / 20 000	1
412 H	13.5	7.9	12	10...14	29	4.7	■	1.6	8 100	-20...+60	45 000 / 15 000	2
414	10	5.9	24	20...28	18	3.8	■	1.0	6 000	-20...+70	50 000 / 20 000	1
414 H	13.5	7.9	24	20...26.5	29	4.7	■	1.6	8 100	-20...+60	45 000 / 15 000	2

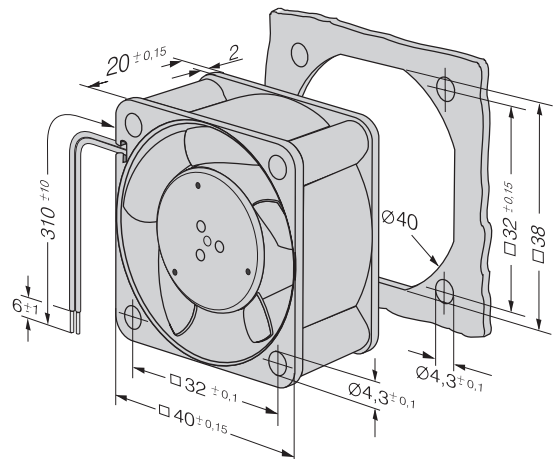
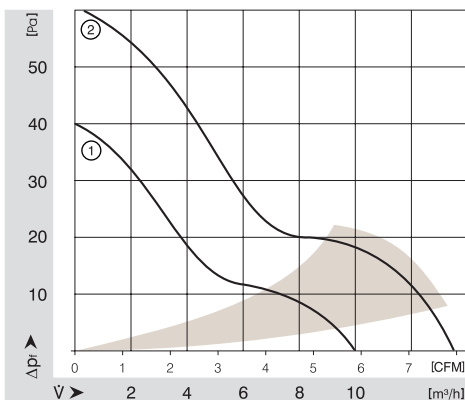



- Speed-proportional rectangular pulse for external speed monitoring of fan motor
- 2 pulses per revolution
- Open-Collector signal output
- Extremely wide operating voltage range (5 ... 60 V)
- Easy adaptation to user interface
- Connection via separate lead
- The sensor signal also serves as a major comparison variable for setting and maintaining the desired speed for interactive or controlled cooling with one or several interconnected fans.

ebm-papst • St. Georgen

Electrical connection

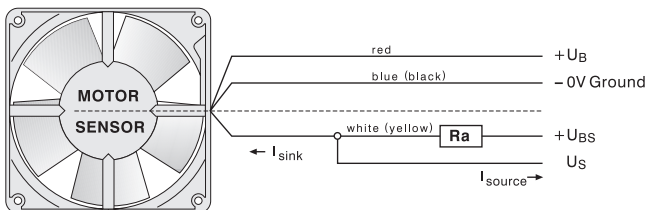

$$R_a = \frac{U_{BS} - U_{SLOW}}{I_{SINK}}$$

All voltages measured to ground.
External load resistance Ra from US to UBS required.

Signal output voltage

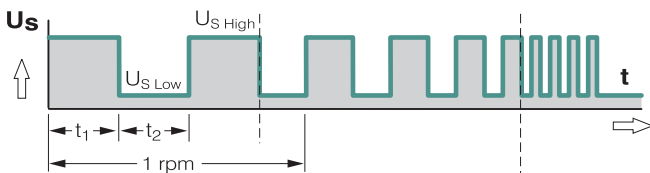

Fan speed

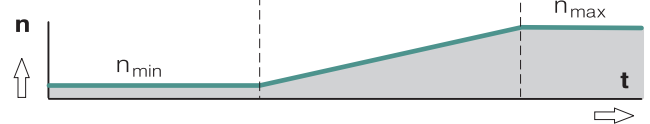

Signal symmetry $[t_1, t_2] = 0.8 \dots 1.2$
Signal frequency $[F] = 2 \times n/60$ Hz

Attention:

With these fan options, deviations in regard to temperature range, voltage range and power consumption are possible compared with standard fan data.

Signal data

Type	Sensor signal US Low V DC	Condition: Isink mA	Sensor signal US High V DC	Condition: Isource mA	Sensor operating voltage UBS V DC	Perm. sink current Isink max. mA
255 N/2	≤ 0.4	≤ 2	30	0	≤ 30	2
255 H/2	≤ 0.4	≤ 2	30	0	≤ 30	2
252 N/2	≤ 0.4	≤ 2	30	0	≤ 30	2
405 F/2	≤ 0.4	1	30	0	≤ 30	≤ 2
405 F/2 H	≤ 0.4	1	30	0	≤ 30	≤ 2
412 F/2 H	≤ 0.4	1	30	0	≤ 30	≤ 2
414 F/2	≤ 0.4	1	30	0	≤ 30	≤ 2
405 /2	≤ 0.4	1	30	0	≤ 30	≤ 2
412 /2	≤ 0.4	1	30	0	≤ 30	≤ 2
414 /2	≤ 0.4	1	30	0	≤ 30	≤ 2
414 /2 H	≤ 0.4	1	30	0	≤ 30	≤ 2
412 J/2 H	≤ 0.4	1	30	0	≤ 30	≤ 4
412 J/2 HH	≤ 0.4	1	30	0	≤ 30	≤ 4
414 J/2 H	≤ 0.4	2	30	0	≤ 30	≤ 4
414 J/2 HH	≤ 0.4	2	30	0	≤ 30	≤ 4
512 F/2	≤ 0.4	1	30	0	≤ 30	≤ 2
514 F/2	≤ 0.4	1	30	0	≤ 30	≤ 2
612 F/2	≤ 0.4	1	30	0	≤ 30	≤ 2
612 F/2 H	≤ 0.4	1	30	0	≤ 30	≤ 2
614 F/2	≤ 0.4	1	30	0	≤ 30	≤ 2
612 N/2 H	≤ 0.4	1	30	0	≤ 30	≤ 2
612 N/2 NHH-120	≤ 0.4	1	30	0	≤ 30	≤ 2
612 N/2 N	≤ 0.4	1	30	0	≤ 30	≤ 2
614 N/2 H	≤ 0.4	1	30	0	≤ 30	≤ 2
614 N/2 HH-121	≤ 0.4	1	30	0	≤ 30	≤ 2
614 N/2 M	≤ 0.4	2	28	0	≤ 30	≤ 4
712 F/2 L	≤ 0.4	1	30	0	≤ 30	≤ 2
712 F/2 M	≤ 0.4	1	30	0	≤ 30	≤ 2
8412 N/2 GL	≤ 0.4	2	28	0	≤ 28	≤ 4
8412 N/2 GM	≤ 0.4	2	28	0	≤ 28	≤ 4
8412 N/2 G	≤ 0.4	2	28	0	≤ 28	≤ 4
8414 N/2 GL	≤ 0.4	2	28	0	≤ 28	≤ 4
8414 N/2 GM	≤ 0.4	2	28	0	≤ 28	≤ 4
8414 N/2 G	≤ 0.4	2	28	0	≤ 28	≤ 4
8414 N/2	≤ 0.4	2	28	0	≤ 28	≤ 4
8412 N/2	≤ 0.4	2	28	0	≤ 28	≤ 4
8412 N/2 H	≤ 0.4	2	28	0	≤ 28	≤ 4
8414 N/2 H	≤ 0.4	2	28	0	≤ 28	≤ 4
8312 /2 HL	≤ 0.4	2	30	0	≤ 30	≤ 4
8314 /2	≤ 0.4	2	30	0	≤ 30	≤ 4
8314 /2 H	≤ 0.4	2	30	0	≤ 30	≤ 4

Available on request:

- Galvanically separated sensor signal circuit
- Varying voltage potentials for power and logic circuit.

Signal data	Sensor signal U _{S, Low}	Condition: I _{sink}	Sensor signal U _{S, High}	Condition: I _{source}	Sensor operating voltage U _{BS}	Perm. sink current I _{sink max.}
Type	V DC	mA	V DC	mA	V DC	mA
8318 /2	≤ 0.4	2	30	0	≤ 30	≤ 4
8318 /2 HL	≤ 0.4	2	30	0	≤ 30	≤ 4
8318 /2 H	≤ 0.4	2	30	0	≤ 30	≤ 4
3412 N/2 GL	≤ 0.4	2	28	0	≤ 28	≤ 4
3412 N/2 GM	≤ 0.4	2	28	0	≤ 28	≤ 4
3412 N/2	≤ 0.4	2	28	0	≤ 28	≤ 4
3412 N/2 G	≤ 0.4	2	28	0	≤ 28	≤ 4
3412 N/2 HH	≤ 0.4	2	28	0	≤ 28	≤ 4
3412 N/2 GHH	≤ 0.4	2	28	0	≤ 28	≤ 4
3412 N/2 H	≤ 0.4	2	28	0	≤ 28	≤ 4
3414 N/2 GH	≤ 0.4	2	28	0	≤ 28	≤ 4
3414 N/2	≤ 0.4	2	28	0	≤ 28	≤ 4
3312 /2	≤ 0.4	2	30	0	≤ 30	≤ 4
3318 /2	≤ 0.4	2	30	0	≤ 30	≤ 4
4412 F/2 GL	≤ 0.4	2	30	0	≤ 30	≤ 4
4412 F/2 GML	≤ 0.4	2	30	0	≤ 30	≤ 4
4412 F/2 M	≤ 0.4	2	30	0	≤ 30	≤ 4
4412 F/2	≤ 0.4	2	30	0	≤ 30	≤ 4
4414 F/2 L	≤ 0.4	2	30	0	≤ 30	≤ 4
4414 F/2 M	≤ 0.4	2	30	0	≤ 30	≤ 4
4414 F/2 G	≤ 0.4	2	30	0	≤ 30	≤ 4
4414 F/2	≤ 0.4	2	30	0	≤ 30	≤ 4
4418 F/2	≤ 0.4	2	30	0	≤ 30	≤ 4
4312 N/2 H	≤ 0.4	2	30	0	≤ 30	≤ 4
4312 N/2 HH	≤ 0.4	2	30	0	≤ 30	≤ 4
4312 /2	≤ 0.4	2	30	0	≤ 30	≤ 4
4314 /2 G	≤ 0.4	2	30	0	≤ 30	≤ 4
4314 /2	≤ 0.4	2	30	0	≤ 30	≤ 4
4318 /2 G	≤ 0.4	2	30	0	≤ 30	≤ 4
4318 /2 M	≤ 0.4	2	30	0	≤ 30	≤ 4
4318 /2	≤ 0.4	2	30	0	≤ 30	≤ 4
4212 N/2 GN	≤ 0.4	2	30	0	≤ 30	≤ 4
4212 N/2 H	≤ 0.4	2	30	0	≤ 30	≤ 4
4214 N/2 GN	≤ 0.4	2	30	0	≤ 30	≤ 4
4214 N/2 H	≤ 0.4	2	30	0	≤ 30	≤ 4
4218 N/2 GN	≤ 0.4	2	30	0	≤ 30	≤ 4
4218 N/2 H	≤ 0.4	2	30	0	≤ 30	≤ 4
4212 /2 M	≤ 0.4	2	30	0	≤ 30	≤ 4
4212 /2	≤ 0.4	2	30	0	≤ 30	≤ 4
4212 /2 H	≤ 0.4	2	30	0	≤ 30	≤ 4
4214 /2	≤ 0.4	2	30	0	4-30	≤ 4

Signal data	Sensor signal U _{S, Low}	Condition: I _{sink}	Sensor signal U _{S, High}	Condition: I _{source}	Sensor operating voltage U _{BS}	Perm. sink current I _{sink max.}
Type	V DC	mA	V DC	mA	V DC	mA
4214 /2 H	≤ 0.4	2	30	0	4-30	≤ 4
4218 /2	≤ 0.4	2	30	0	4-30	≤ 4
4218 /2 H	≤ 0.4	2	30	0	4-30	≤ 4
4182 N/2 X	≤ 0.4	2	30	0	4-30	≤ 4
4184 N/2 GX	≤ 0.4	2	30	0	4-30	≤ 4
4184 N/2 X	≤ 0.4	2	30	0	4-30	≤ 4
4184 N/2 XH	≤ 0.4	2	30	0	4-30	≤ 4
5112 N/2	≤ 0.4	2	15	0	≤ 5	≤ 20
5114 N/2	≤ 0.4	2	60	0	≤ 60	≤ 20
5118 N/2	≤ 0.4	2	60	0	≤ 60	≤ 20
5212 N/2 H	≤ 0.4	2	30	0	4-30	≤ 2
5212 N/2 N	≤ 0.4	2	30	0	4-30	≤ 2
5214 N/2 N	≤ 0.4	2	30	0	4-30	≤ 2
5218 N/2 H	≤ 0.4	2	30	0	4-30	≤ 2
7112 N/2	≤ 0.4	2	60	0	≤ 60	≤ 20
7114 N/2	≤ 0.4	2	30	0	≤ 30	≤ 20
7118 N/2	≤ 0.4	2	60	0	≤ 60	≤ 20
6224 N/2	≤ 0.4	8	30	0	≤ 30	≤ 20
6248 N/2	≤ 0.4	8	60	0	≤ 30	≤ 20
DV 6224 /2	≤ 0.4	2	30	0	≤ 60	≤ 20
6424 /2	≤ 0.4	2	60	0	≤ 60	≤ 20
6448 /2	≤ 0.4	2	60	0	≤ 60	≤ 20
6448 /2 T	≤ 0.4	2	60	0	≤ 60	≤ 20
RL 48-19/12/2	≤ 0.4	2	28	0	4-30	≤ 4
RL 48-19/14/2	≤ 0.4	2	28	0	4-30	≤ 4
RL 90-18/12N/2	≤ 0.4	2	30	0	≤ 30	≤ 4
RL 90-18/14N/2	≤ 0.4	2	30	0	≤ 30	≤ 4
RG 90-18/12N/2	≤ 0.4	2	30	0	≤ 30	≤ 4
RG 90-18/14N/2	≤ 0.4	2	30	0	≤ 30	≤ 4
RG 125-19/14N/2	≤ 0.4	2	30	0	≤ 30	≤ 4
RG 125-19/18N/2	≤ 0.4	2	60	0	≤ 30	≤ 4
RER 125-19/14N/2	≤ 0.4	2	30	0	≤ 30	≤ 4
RG 160-28/14N/2	≤ 0.4	2	30	0	≤ 30	≤ 20

Attention:

With these fan options, deviations in regard to temperature range, voltage range and power consumption are possible compared with standard fan data.



Компания «ЭлектроПласт» предлагает заключение долгосрочных отношений при поставках импортных электронных компонентов на взаимовыгодных условиях!

Наши преимущества:

- Оперативные поставки широкого спектра электронных компонентов отечественного и импортного производства напрямую от производителей и с крупнейших мировых складов;
- Поставка более 17-ти миллионов наименований электронных компонентов;
- Поставка сложных, дефицитных, либо снятых с производства позиций;
- Оперативные сроки поставки под заказ (от 5 рабочих дней);
- Экспресс доставка в любую точку России;
- Техническая поддержка проекта, помощь в подборе аналогов, поставка прототипов;
- Система менеджмента качества сертифицирована по Международному стандарту ISO 9001;
- Лицензия ФСБ на осуществление работ с использованием сведений, составляющих государственную тайну;
- Поставка специализированных компонентов (Xilinx, Altera, Analog Devices, Intersil, Interpoint, Microsemi, Aeroflex, Peregrine, Syfer, Eurofarad, Texas Instrument, Miteq, Cobham, E2V, MA-COM, Hittite, Mini-Circuits, General Dynamics и др.);

Помимо этого, одним из направлений компании «ЭлектроПласт» является направление «Источники питания». Мы предлагаем Вам помощь Конструкторского отдела:

- Подбор оптимального решения, техническое обоснование при выборе компонента;
- Подбор аналогов;
- Консультации по применению компонента;
- Поставка образцов и прототипов;
- Техническая поддержка проекта;
- Защита от снятия компонента с производства.



Как с нами связаться

Телефон: 8 (812) 309 58 32 (многоканальный)

Факс: 8 (812) 320-02-42

Электронная почта: org@eplast1.ru

Адрес: 198099, г. Санкт-Петербург, ул. Калинина, дом 2, корпус 4, литера А.