

LTC3310S 5V, 10A Synchronous Step Down Silent Switcher in 3mm x3mm LQFN

DESCRIPTION

Demonstration Circuit DC2629A features the **LTC®3310S** 10A, Low Voltage, Synchronous Step-Down Silent Switcher® 2 operating as a 2MHz 3.3V to 1.2V 10A buck regulator. The LTC3310S supports output voltages from 0.5V to V_{IN} with operating frequencies from 500kHz up to 5MHz. The LTC3310S is a compact, ultralow emission, high efficiency, and high speed synchronous monolithic step-down switching regulator. The integrated bypass capacitors optimize all the fast current loops and make it easier to minimize EMI/EMC emissions by reducing layout sensitivity. Fast minimum on-time of 35ns enables high V_{IN} to low V_{OUT} conversion at high frequency.

DC2629A is set up to run in Forced Continuous Mode with a 2MHz switching frequency but can be configured to Pulse Skip Mode and different switching frequencies. RT is connected to V_{IN} which sets the MODE/SYNC pin as an input and allows the LTC3310S to sync from an external clock. Connecting the MODE/SYNC pin to V_{IN} sets the mode to Forced Continuous Mode and connecting the MODE/SYNC pin to GND sets the mode to Pulse Skip Mode. The Efficiency vs. Load graph shows the efficiency

and the power loss of the circuit with a 3.3V input in forced continuous mode operation.

The DC2629A also has an EMI filter to reduce conducted EMI. This EMI filter can be included by applying the input voltage at the V_{IN} EMI terminal. The EMI performance of the board is shown in the EMI TEST RESULTS section. The red lines in the EMI performance graphs illustrate the CISPR25 Class 5 peak limits for the conducted and radiated emission tests.

The LTC3310S data sheet gives a complete description of the part, operation and application information. The data sheet must be read in conjunction with this demo. The LTC3310S is assembled in a 3mm x 3mm LQFN package with exposed pads for low thermal resistance. The layout recommendations for low EMI operation and maximum thermal performance are available in the data sheet section Low EMI PCB Layout.

[Design files for this circuit board are available.](#)

All registered trademarks and trademarks are the property of their respective owners.

PERFORMANCE SUMMARY

Specifications are at $T_A = 25^\circ\text{C}$

SYMBOL	PARAMETER	CONDITIONS	MIN	TYP	MAX	UNITS
V_{IN}/V_{IN} EMI	DC2629A Input Voltage Range		2.25		5.5	V
V_{OUT}	DC2629A V_{OUT} Voltage Range		1.183	1.2	1.217	V
I_{OUT}	DC2629A Output Current				10	A
f_{SW}	Switching Frequency		1.8		2.2	MHz
EFF	Efficiency	$V_{IN} = 3.3\text{V}, I_{OUT} = 5\text{A}$		91		%

DEMO MANUAL DC2629A

BOARD PHOTO

1.2V 10A Step-Down Converter

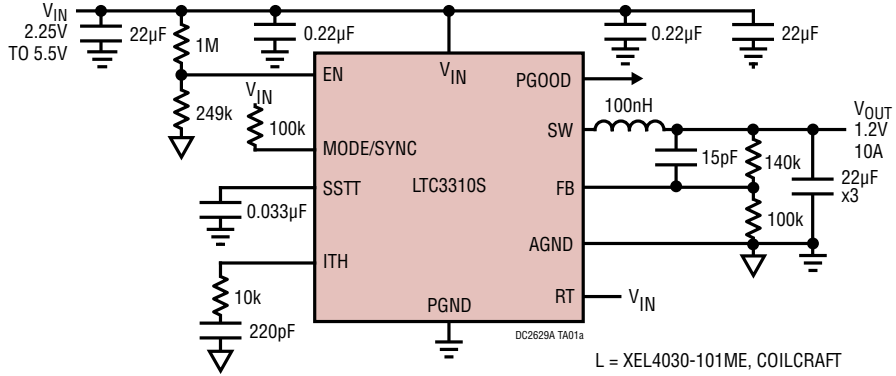

Efficiency vs Load Current

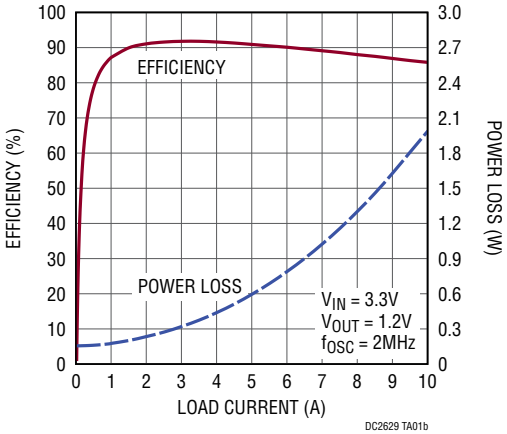

EMI TEST RESULTS

CISPR25 Conducted EMI Emissions with Class 5 Peak Limits (Voltage Method)

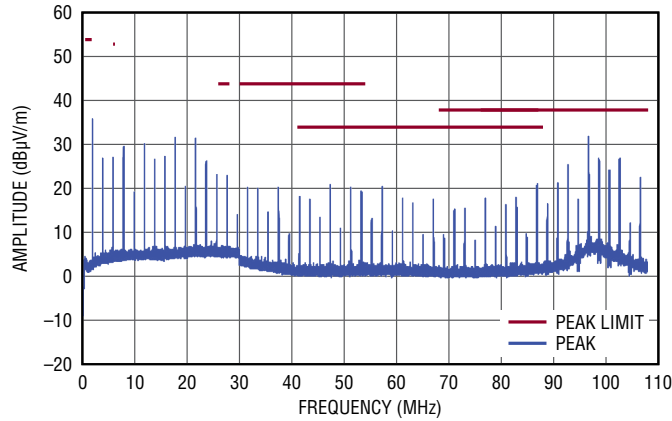

DC2629A DEMO BOARD
 (WITH VOLTAGE APPLIED TO V_{IN} EMI INPUT)
 3.3V INPUT TO 1.2V OUTPUT AT 7.5A, $f_{SW} = 2\text{MHz}$

DC2629A G01

Radiated EMI Performance (CISPR25 Radiated Emissions Test with Class 5 Peak Limits)

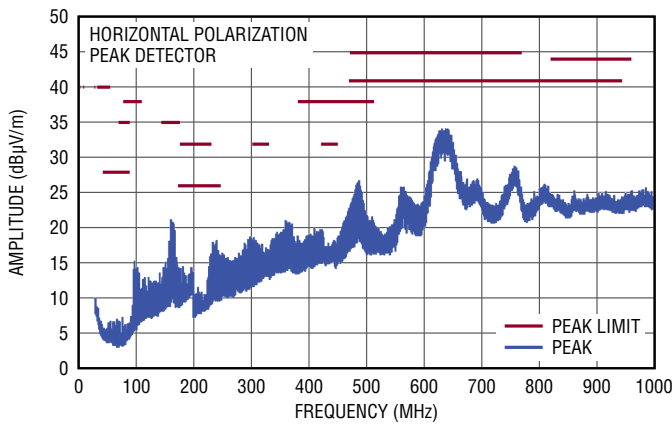

DC2629A DEMO BOARD
 (WITH VOLTAGE APPLIED TO V_{IN} EMI INPUT)
 3.3V INPUT TO 1.2V OUTPUT AT 7.5A, $f_{SW} = 2\text{MHz}$

DC2629A G02

Radiated EMI Performance (CISPR25 Radiated Emissions Test with Class 5 Peak Limits)

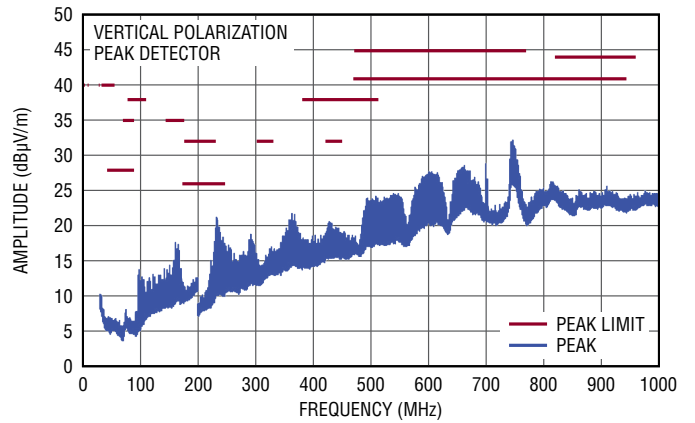

DC2629A DEMO BOARD
 (WITH VOLTAGE APPLIED TO V_{IN} EMI INPUT)
 3.3V INPUT TO 1.2V OUTPUT AT 7.5A, $f_{SW} = 2\text{MHz}$

DC2629A G03

QUICK START PROCEDURE

Demonstration circuit 2629A is easy to set up and evaluate the performance of the LTC3310S. Refer to Figure 1 for proper measurement equipment setup and follow the procedure below:

NOTE: For accurate V_{IN} , V_{OUT} and efficiency measurements, measure V_{IN} at the V_{IN} SNSE and GND SNSE turrets and V_{OUT} at the V_{OUT} SNSE and GND SNSE turrets as illustrated as VM1 and VM2 in Figure 1. When measuring the input or output voltage ripple, care must be taken to avoid a long ground lead on the oscilloscope probe. Measure the output voltage ripple by touching the probe tip directly across the output turrets or to TP1 as shown in Figure 2.

1. Set the JP1 Jumper to the HI position.
2. With power off, connect the input power supply to V_{IN} and GND. If the input EMI filter is desired, connect the input power supply to V_{IN} EMI and GND.
3. Slowly increase PS1 to 1.0V. If AM1 reads less than 20mA, increase PS1 to 3.3V. Verify that VM1 reads 3.3V and VM2 reads 1.2V. Record VM1, VM2, VM3 AM1 and AM2. Connect an oscilloscope voltage probe as shown in Figure 2. Set Channel to AC coupled, voltage scale to 20mV and time base to 10 μ s. Record V_{OUT} ripple voltage. Verify that PGOOD voltage is above 3V. Calculate Die temperature using formula below:

$$T_J(^{\circ}\text{C}) = \frac{V_{SSTT}}{4\text{mV}} - 237 \quad (1)$$

4. Increase the load by 1A intervals up to 10A and observe the voltage output regulation, ripple voltage, and the voltage on the SSTT turret.

5. If Pulse Skip Mode is desired, set PS1 to 0V. Install a 0 Ω resistor in the R6 location or short the MODE/SYNC turret to GND. Repeat steps 1 through 4. In step 4 observe that the switching waveform is now operating in Pulse Skip Mode at low currents.
6. To change the frequency, remove R4 and R6 if installed. Install the desired RT resistor in the R7 location. Note, the MODE/SYNC pin is an output when R4 is installed and the MODE/SYNC pin should have high impedance to GND and V_{IN} . Size the inductor, output capacitors and compensation components to provide the desired inductor ripple and a stable output. Refer to the LTC3310S datasheet and [LTPowerCAD](#) for more information on choosing the required components.
7. To test the transient response with a base load, add the desired resistor to produce a minimum load between V_{OUT} and I_STEP turrets (RL shown on Figure 1). Note that the total load resistance will be RL plus R14 (100m Ω). Adjust a signal generator with a 10ms period, 10% duty cycle and an amplitude from 1V to 2V to start.
8. Measure the I_STEP voltage to observe the current, $V_{I_STEP}/100\text{m}\Omega$. Adjust the amplitude of the pulse to provide the desired transient. Adjust the rising and falling edge of the pulse to provide the desired ramp rate. Figure 3 shows a load step from 2A ($R_L = 0.51\Omega$) to 8A. Refer to the following equations:

$$I_{OUT} = \frac{V_{I_STEP}}{100\text{m}\Omega} \quad (2)$$

$$V_{GS} = V_{SG_INPUT} - V_{I_STEP} \quad (3)$$
9. When done, turn off SG1, PS1 and Load. Remove all connections to demo board.

QUICK START PROCEDURE

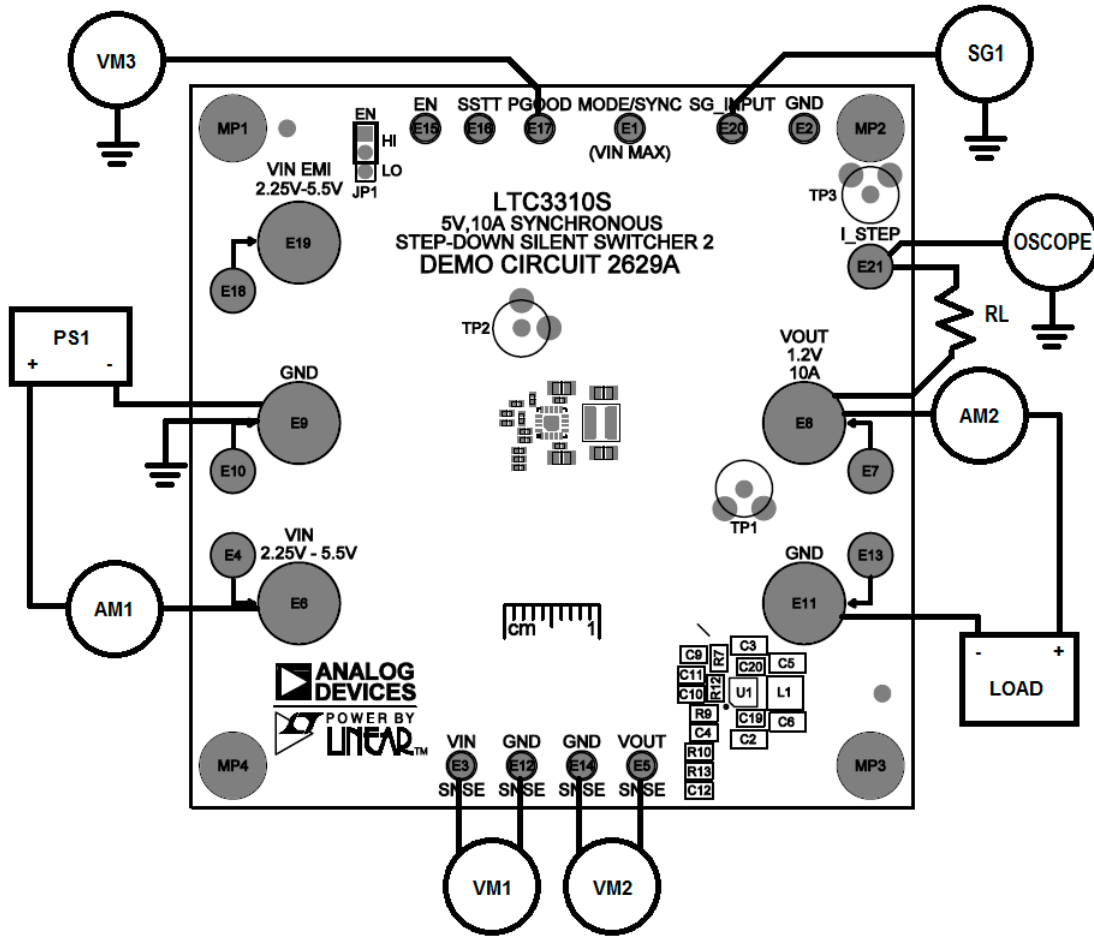

Figure 1. Test setup for the DC2629A Demo Board

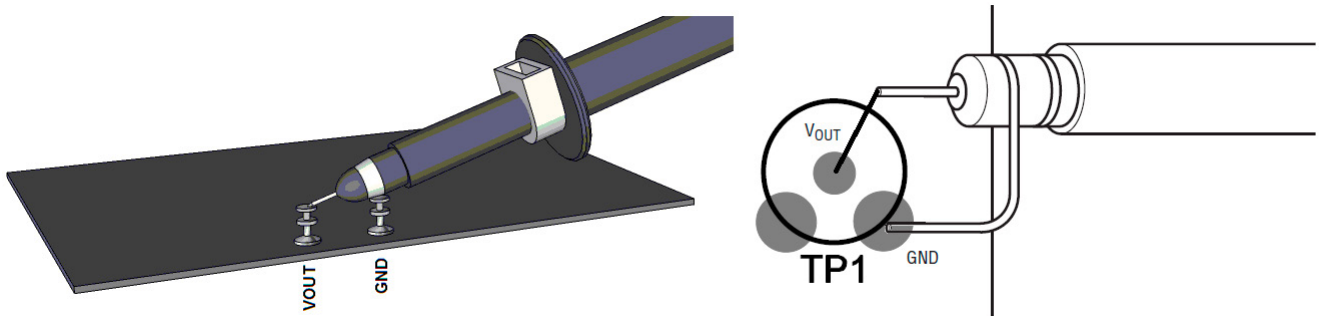

Figure 2. Technique for Measuring Output Ripple and Step Response

QUICK START PROCEDURE

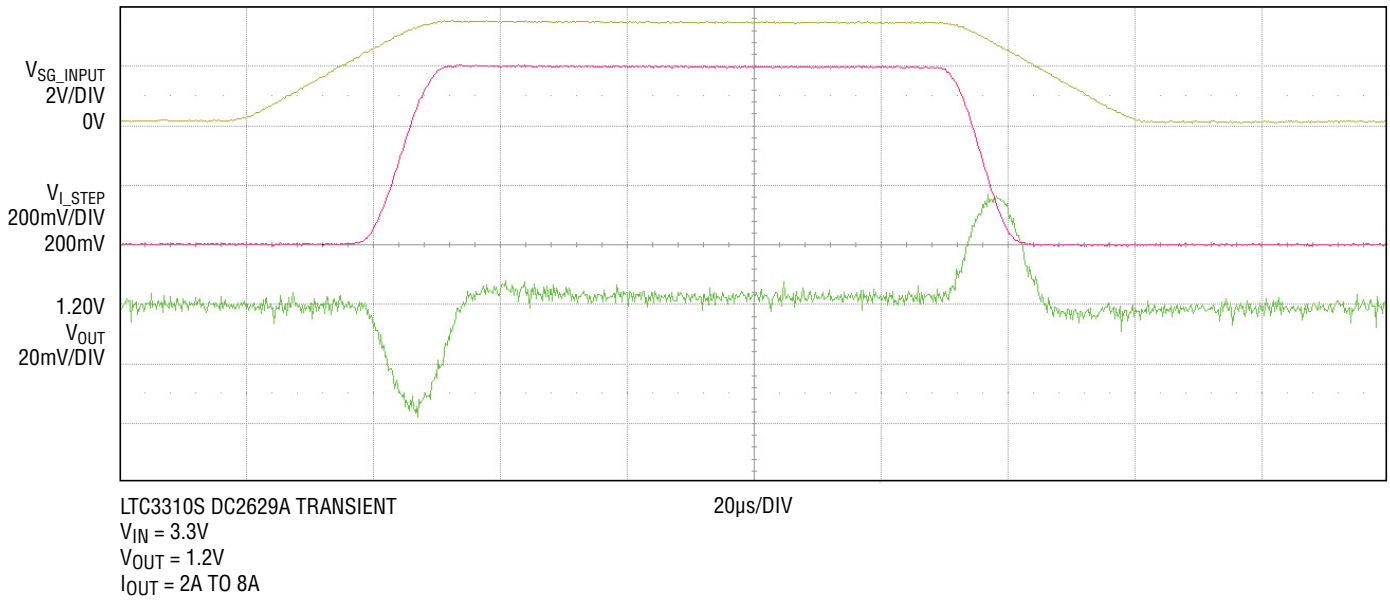

Figure 3. Technique for Measuring Load Step Response

THEORY OF OPERATION

Introduction to the DC2629A

The DC2629A demonstration circuit features the LTC3310S, a Low Voltage Synchronous Step-Down Silent Switcher. The LTC3310S is a monolithic, constant frequency, current mode step-down DC/DC converter. An oscillator, with frequency set using a resistor on the RT pin, turns on the internal top power switch at the beginning of each clock cycle. Current in the inductor then increases until the top switch comparator trips and turns off the top power switch. The peak inductor current, at which the top switch turns off, is controlled by the voltage on the internal ITH node. The error amplifier servos the ITH node by comparing the voltage on the V_{FB} pin with an internal 500mV reference. When the load current increases, it causes a reduction in the feedback voltage relative to the reference leading the error amplifier to raise the ITH voltage until the average inductor current matches the new load current. When the top switch turns off, the synchronous power switch turns on until the next clock cycle begins or the inductor current falls to zero. If overload conditions result in excessive current flowing through the bottom switch, the next clock cycle will be delayed until the switch current returns to a safe level.

If the EN pin is low, the LT3310S is in shutdown and in a low quiescent current state. When the EN pin is above its threshold, the switching regulator will be enabled.

The MODE/SYNC pin synchronizes the switching frequency to an external clock, is a clock output or sets the PWM mode. The PWM modes of operation are either pulse skip or forced continuous. See the LTC3310S datasheet for more detailed information.

The maximum allowable operating frequency is influenced by the minimum on time of the top switch, the ratio of V_{OUT} to V_{IN} and the available inductor values. The maximum allowable operating frequency may be calculated in the formula below.

$$f_{\text{SW}(\text{MAX})} = \frac{V_{\text{OUT}}}{V_{\text{IN}(\text{MAX})} \cdot T_{\text{ON}(\text{MIN})}} \quad (4)$$

Select an operating switching frequency below $f_{\text{SW}(\text{MAX})}$. Typically, it is desired to obtain an inductor current of 30% of the maximum LTC3310S operating load, 10A. Use the formulas below to calculate the inductor value to obtain a 30% (3A) inductor ripple for the operating frequency.

$$L \geq \frac{V_{\text{OUT}}}{3A \cdot f_{\text{SW}}} \cdot \left(1 - \frac{V_{\text{OUT}}}{V_{\text{IN}(\text{MAX})}} \right) \text{ for } \frac{V_{\text{OUT}}}{V_{\text{IN}(\text{MAX})}} \leq 0.5 \quad (5)$$

$$L \geq \frac{0.25 \cdot V_{\text{IN}(\text{MAX})}}{3A \cdot f_{\text{SW}}} \text{ for } \frac{V_{\text{OUT}}}{V_{\text{IN}(\text{MAX})}} > 0.5 \quad (6)$$

When determining the compensation components, C4, C10, C11 and R12, controlling the loop stability and transient response are the two main considerations. The LTC3310S has been designed to operate at a high bandwidth for fast transient response capabilities. This reduces output capacitance required to meet the desired transient voltage range. The mid-band gain of the loop increases with R12 and the bandwidth of the loop increases with decreasing C11. C4 along with R4 provides a phase lead which will improve the phase margin. C10 along with R12 provides a high frequency pole to reduce the high frequency gain.

Loop stability is generally measured using the Bode Plot method of plotting loop gain in dB and phase shift in degrees. The 0dB crossover frequency should be less than 1/6 of the operating frequency to reduce the effects of added phase shift of the modulator. The control loop phase margin goal should be 45° or greater and a gain margin goal of 8dB or greater.

DEMO MANUAL DC2629A

SCHEMATIC DIAGRAM

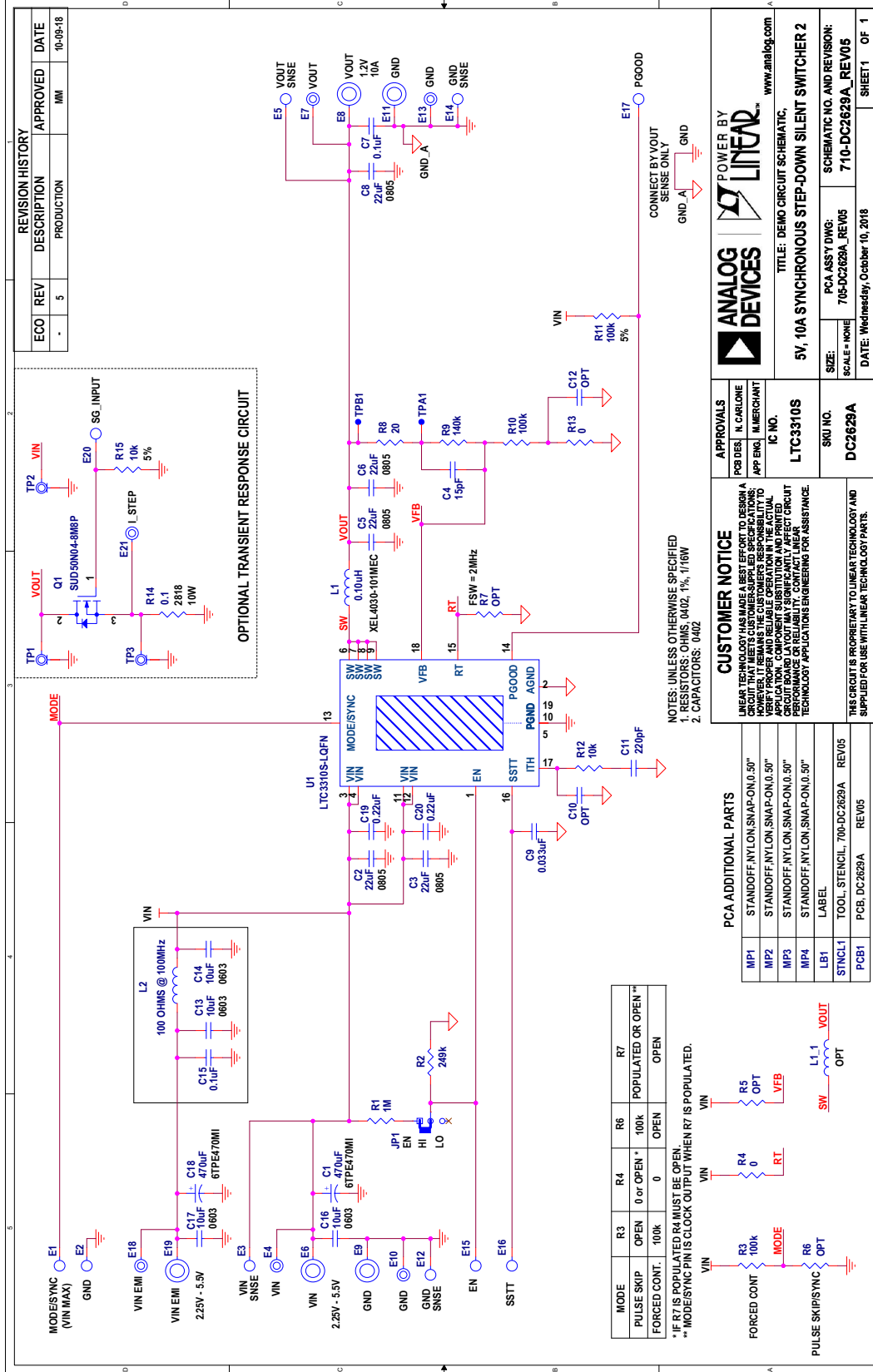

PARTS LIST

ITEM	QTY	REFERENCE	PART DESCRIPTION	MANUFACTURER/PART NUMBER
Required Circuit Components				
1	4	C2, C3, C5, C6	CAP., 22uF, X5R, 25V, 20%, 0805	SAMSUNG, CL21A226MAQNNNE
2	1	C4	CAP., 15pF, C0G, 50V, 5%, 0402	KEMET, C0402C150J5GAC7867
3	1	C9	CAP., 0.033uF, X7R, 25V, 10%, 0402	KEMET, C0402C333K3RACTU
4	1	C11	CAP., 220pF, X7R, 50V, 10%, 0402	YAGEO, CC0402KRX7R9BB221
5	2	C13, C14	CAP., 10uF, X5R, 10V, 20%, 0603	AVX, 0603ZD106MAT2A
6	1	L1	IND., 0.10uH 20% SHEILDDED POWER INDUCTOR	COILCRAFT, XEL4030-101MEC
7	1	R9	RES., 140k OHMS, 1%, 1/16W, 0402, AEC-Q200	VISHAY, CRCW0402140KFKED
8	1	R10	RES., 100k OHMS, 1%, 1/16W, 0402, AEC-Q200	VISHAY, CRCW0402100KFKED
9	1	R12	RES., 10k OHMS, 1%, 1/10W, 0402, AEC-Q200	PANASONIC, ERJ2RKF1002X
10	1	U1	IC, Low Voltage Syn. Stepdown Reg., LQFN-18	ANALOG DEVICES, LTC3310SEV#PBF
Additional Demo Board Circuit Components				
1	2	C1, C18	CAP., 470uF, TANT. POSCAP, 6.3V, 20%, 7343, 18mOHMS, TPE	PANASONIC, 6TPE470MI
2	2	C7, C15	CAP., 0.1uF, X5R, 25V, 10%, 0402	AVX, 04023D104KAT2A
3	1	C8	CAP., 22uF, X5R, 25V, 20%, 0805	SAMSUNG, CL21A226MAQNNNE
4	2	C16, C17	CAP., 10uF, X5R, 10V, 20%, 0603	AVX, 0603ZD106MAT2A
5	2	C19, C20	CAP., 0.22uF, X7R, 16V, 10%, 0402, AEC-Q200	MURATA, GCM155R71C224KE02D
6	1	L2	IND., 100 OHMS @ 100MHz, FERRITE BEAD, 25%, 8A, 6mOHMS, 1812	WURTH ELEKTRONIK, 74279226101
7	1	Q1	XSTR., MOSFET, N-CH, 40V, TO-252 (DPAK)	VISHAY, SUD50N04-8M8P-4GE3
8	1	R1	RES., 1M OHMS, 1%, 1/16W, 0402, AEC-Q200	VISHAY, CRCW04021M00FKED
9	1	R2	RES., 249k OHMS, 1%, 1/16W, 0402	VISHAY, CRCW0402249KFKED
10	2	R3, R11	RES., 100k OHMS, 5%, 1/16W, 0402, AEC-Q200	VISHAY, CRCW0402100KJNED
11	2	R4, R13	RES., 0 OHM, 1/16W, 0402, AEC-Q200	VISHAY, CRCW04020000Z0ED
12	1	R8	RES., 20 OHMS, 1%, 1/16W, 0402, AEC-Q200	VISHAY, CRCW040220R0FKED
13	1	R14	RES 0.1 OHM 1% 10W 2818	VISHAY DALE, WSH2818R1000FEA
14	1	R15	RES., 10k OHMS, 5%, 1/16W, 0402, AEC-Q200	VISHAY, CRCW040210K0JNED
Hardware: For Demo Board Only				
1	10	E1-E3, E5, E12, E14-E17, E20	TEST POINT, TURRET, 0.064", MTG. HOLE	MILL-MAX, 2308-2-00-80-00-00-07-0
2	6	E4, E7, E10, E13, E18, E21	TEST POINT, TURRET, 0.094", MTG. HOLE	MILL-MAX, 2501-2-00-80-00-00-07-0
3	5	E6, E8, E9, E11, E19	CONN., BANANA JACK, FEMALE, THT, NON-INSULATED, SWAGE	KEYSTONE, 575-4
4	1	JP1	CONN., HDR, MALE, 1x3, 2mm, VERT, STR, THT	WURTH ELEKTRONIK, 62000311121
5	4	MP1-MP4	STANDOFF, NYLON, SNAP-ON, 0.50"	KEYSTONE, 8833
6	1	XJP4	CONN., SHUNT, FEMALE, 2 POS, 2mm	WURTH ELEKTRONIK, 60800213421



ESD Caution

ESD (electrostatic discharge) sensitive device. Charged devices and circuit boards can discharge without detection. Although this product features patented or proprietary protection circuitry, damage may occur on devices subjected to high energy ESD. Therefore, proper ESD precautions should be taken to avoid performance degradation or loss of functionality.

Legal Terms and Conditions

By using the evaluation board discussed herein (together with any tools, components documentation or support materials, the "Evaluation Board"), you are agreeing to be bound by the terms and conditions set forth below ("Agreement") unless you have purchased the Evaluation Board, in which case the Analog Devices Standard Terms and Conditions of Sale shall govern. Do not use the Evaluation Board until you have read and agreed to the Agreement. Your use of the Evaluation Board shall signify your acceptance of the Agreement. This Agreement is made by and between you ("Customer") and Analog Devices, Inc. ("ADI"), with its principal place of business at One Technology Way, Norwood, MA 02062, USA. Subject to the terms and conditions of the Agreement, ADI hereby grants to Customer a free, limited, personal, temporary, non-exclusive, non-sublicensable, non-transferable license to use the Evaluation Board FOR EVALUATION PURPOSES ONLY. Customer understands and agrees that the Evaluation Board is provided for the sole and exclusive purpose referenced above, and agrees not to use the Evaluation Board for any other purpose. Furthermore, the license granted is expressly made subject to the following additional limitations: Customer shall not (i) rent, lease, display, sell, transfer, assign, sublicense, or distribute the Evaluation Board; and (ii) permit any Third Party to access the Evaluation Board. As used herein, the term "Third Party" includes any entity other than ADI, Customer, their employees, affiliates and in-house consultants. The Evaluation Board is NOT sold to Customer; all rights not expressly granted herein, including ownership of the Evaluation Board, are reserved by ADI. CONFIDENTIALITY. This Agreement and the Evaluation Board shall all be considered the confidential and proprietary information of ADI. Customer may not disclose or transfer any portion of the Evaluation Board to any other party for any reason. Upon discontinuation of use of the Evaluation Board or termination of this Agreement, Customer agrees to promptly return the Evaluation Board to ADI. ADDITIONAL RESTRICTIONS. Customer may not disassemble, decompile or reverse engineer chips on the Evaluation Board. Customer shall inform ADI of any occurred damages or any modifications or alterations it makes to the Evaluation Board, including but not limited to soldering or any other activity that affects the material content of the Evaluation Board. Modifications to the Evaluation Board must comply with applicable law, including but not limited to the RoHS Directive. TERMINATION. ADI may terminate this Agreement at any time upon giving written notice to Customer. Customer agrees to return to ADI the Evaluation Board at that time. LIMITATION OF LIABILITY. THE EVALUATION BOARD PROVIDED HEREUNDER IS PROVIDED "AS IS" AND ADI MAKES NO WARRANTIES OR REPRESENTATIONS OF ANY KIND WITH RESPECT TO IT. ADI SPECIFICALLY DISCLAIMS ANY REPRESENTATIONS, ENDORSEMENTS, GUARANTEES, OR WARRANTIES, EXPRESS OR IMPLIED, RELATED TO THE EVALUATION BOARD INCLUDING, BUT NOT LIMITED TO, THE IMPLIED WARRANTY OF MERCHANTABILITY, TITLE, FITNESS FOR A PARTICULAR PURPOSE OR NON-INFRINGEMENT OF INTELLECTUAL PROPERTY RIGHTS. IN NO EVENT WILL ADI AND ITS LICENSORS BE LIABLE FOR ANY INCIDENTAL, SPECIAL, INDIRECT, OR CONSEQUENTIAL DAMAGES RESULTING FROM CUSTOMER'S POSSESSION OR USE OF THE EVALUATION BOARD, INCLUDING BUT NOT LIMITED TO LOST PROFITS, DELAY COSTS, LABOR COSTS OR LOSS OF GOODWILL. ADI'S TOTAL LIABILITY FROM ANY AND ALL CAUSES SHALL BE LIMITED TO THE AMOUNT OF ONE HUNDRED US DOLLARS (\$100.00). EXPORT. Customer agrees that it will not directly or indirectly export the Evaluation Board to another country, and that it will comply with all applicable United States federal laws and regulations relating to exports. GOVERNING LAW. This Agreement shall be governed by and construed in accordance with the substantive laws of the Commonwealth of Massachusetts (excluding conflict of law rules). Any legal action regarding this Agreement will be heard in the state or federal courts having jurisdiction in Suffolk County, Massachusetts, and Customer hereby submits to the personal jurisdiction and venue of such courts. The United Nations Convention on Contracts for the International Sale of Goods shall not apply to this Agreement and is expressly disclaimed.



Компания «ЭлектроПласт» предлагает заключение долгосрочных отношений при поставках импортных электронных компонентов на взаимовыгодных условиях!

Наши преимущества:

- Оперативные поставки широкого спектра электронных компонентов отечественного и импортного производства напрямую от производителей и с крупнейших мировых складов;
- Поставка более 17-ти миллионов наименований электронных компонентов;
- Поставка сложных, дефицитных, либо снятых с производства позиций;
- Оперативные сроки поставки под заказ (от 5 рабочих дней);
- Экспресс доставка в любую точку России;
- Техническая поддержка проекта, помощь в подборе аналогов, поставка прототипов;
- Система менеджмента качества сертифицирована по Международному стандарту ISO 9001;
- Лицензия ФСБ на осуществление работ с использованием сведений, составляющих государственную тайну;
- Поставка специализированных компонентов (Xilinx, Altera, Analog Devices, Intersil, Interpoint, Microsemi, Aeroflex, Peregrine, Syfer, Eurofarad, Texas Instrument, Miteq, Cobham, E2V, MA-COM, Hittite, Mini-Circuits, General Dynamics и др.);

Помимо этого, одним из направлений компании «ЭлектроПласт» является направление «Источники питания». Мы предлагаем Вам помощь Конструкторского отдела:

- Подбор оптимального решения, техническое обоснование при выборе компонента;
- Подбор аналогов;
- Консультации по применению компонента;
- Поставка образцов и прототипов;
- Техническая поддержка проекта;
- Защита от снятия компонента с производства.



Как с нами связаться

Телефон: 8 (812) 309 58 32 (многоканальный)

Факс: 8 (812) 320-02-42

Электронная почта: org@eplast1.ru

Адрес: 198099, г. Санкт-Петербург, ул. Калинина, дом 2, корпус 4, литера А.