



Is Now Part of



ON Semiconductor®

To learn more about ON Semiconductor, please visit our website at
www.onsemi.com

Please note: As part of the Fairchild Semiconductor integration, some of the Fairchild orderable part numbers will need to change in order to meet ON Semiconductor's system requirements. Since the ON Semiconductor product management systems do not have the ability to manage part nomenclature that utilizes an underscore (_), the underscore (_) in the Fairchild part numbers will be changed to a dash (-). This document may contain device numbers with an underscore (_). Please check the ON Semiconductor website to verify the updated device numbers. The most current and up-to-date ordering information can be found at www.onsemi.com. Please email any questions regarding the system integration to Fairchild_questions@onsemi.com.

ON Semiconductor and the ON Semiconductor logo are trademarks of Semiconductor Components Industries, LLC dba ON Semiconductor or its subsidiaries in the United States and/or other countries. ON Semiconductor owns the rights to a number of patents, trademarks, copyrights, trade secrets, and other intellectual property. A listing of ON Semiconductor's product/patent coverage may be accessed at www.onsemi.com/site/pdf/Patent-Marking.pdf. ON Semiconductor reserves the right to make changes without further notice to any products herein. ON Semiconductor makes no warranty, representation or guarantee regarding the suitability of its products for any particular purpose, nor does ON Semiconductor assume any liability arising out of the application or use of any product or circuit, and specifically disclaims any and all liability, including without limitation special, consequential or incidental damages. Buyer is responsible for its products and applications using ON Semiconductor products, including compliance with all laws, regulations and safety requirements or standards, regardless of any support or applications information provided by ON Semiconductor. "Typical" parameters which may be provided in ON Semiconductor data sheets and/or specifications can and do vary in different applications and actual performance may vary over time. All operating parameters, including "Typicals" must be validated for each customer application by customer's technical experts. ON Semiconductor does not convey any license under its patent rights nor the rights of others. ON Semiconductor products are not designed, intended, or authorized for use as a critical component in life support systems or any FDA Class 3 medical devices or medical devices with a same or similar classification in a foreign jurisdiction or any devices intended for implantation in the human body. Should Buyer purchase or use ON Semiconductor products for any such unintended or unauthorized application, Buyer shall indemnify and hold ON Semiconductor and its officers, employees, subsidiaries, affiliates, and distributors harmless against all claims, costs, damages, and expenses, and reasonable attorney fees arising out of, directly or indirectly, any claim of personal injury or death associated with such unintended or unauthorized use, even if such claim alleges that ON Semiconductor was negligent regarding the design or manufacture of the part. ON Semiconductor is an Equal Opportunity/Affirmative Action Employer. This literature is subject to all applicable copyright laws and is not for resale in any manner.



FPF2488 Dual Channel Over-Voltage Protection Load Switch

Features

- Dual Channel Power Switch (V_{BUS} and V_{IF})
- Surge Protection under IEC 61000-4-5
 - V_{BUS} : ± 100 V
 - V_{IF} : ± 40 V
- Input Voltage Range
 - V_{BUS} : 2.5 V ~ 23 V
 - V_{IF} : 3.1 V ~ 5.5 V
- Max Continuous Current Capability
 - V_{BUS} : 2.5 A
 - V_{IF} : 6 A
- Ultra Low On-Resistance
 - V_{BUS} : Typ. 33 m Ω
 - V_{IF} : Typ. 10 m Ω
- Over Voltage Protection
 - V_{BUS} : 10 V \pm 100 mV
 - V_{IF} : 5.25 V \pm 250 mV
- LDO Output based V_{BUS_DET} for V_{BUS} Detection
- Active Low Control for V_{BUS} Path
- OTG Functionality on V_{BUS} Path
- Conditional Active High Control for V_{IF} Path
- Reverse-Current Blocking for V_{IF} Path

Applications

- Mobile Handsets and Tablets
- Wearable Devices

Description

The FPF2488 features a 2-channel power switch, which offers surge protection and Over-Voltage Protection (OVP), to protect downstream components and enhancing overall system robustness.

Channel one (V_{BUS}) is an active-low, 28 V/2.5 A rated, power MOSFET switch with an internal clamp supporting ± 100 V surge protection, highly accurate fixed OVP at 10.0 V (± 100 mV), and OTG functionality. Channel two (V_{IF}) is a conditional active-high, 6 V/6 A rated, power MOSFET switch with an integrated TVS supporting ± 40 V surge protection and fixed OVP at 5.25 V (± 250 mV). V_{IF} also provides Reverse Current Blocking (RCB) during its OFF state to minimize leakage current.

V_{BUS_DET} is paired with always ON LDO to power downstream devices even with V_{BUS} is greater than 2.5 V, even when disabled through the ONB pin. This provides power sequence control or a host controlled configuration in system.

The FPF2488 is available in a 15-bump, 1.6 mm x 2.2 mm Wafer-Level Chip-Scale Package (WLCSP) with 0.4 mm pitch.

Related Resources

- <http://www.fairchildsemi.com/>

Ordering Information

| Part Number | Operating Temperature Range | Top Mark | Package | Packing Method |
|-------------|-----------------------------|----------|-----------------------------|----------------|
| FPF2488UCX | -40°C – +85°C | GW | 15-Ball, 0.4 mm Pitch WLCSP | Tape & Reel |

Application Diagram

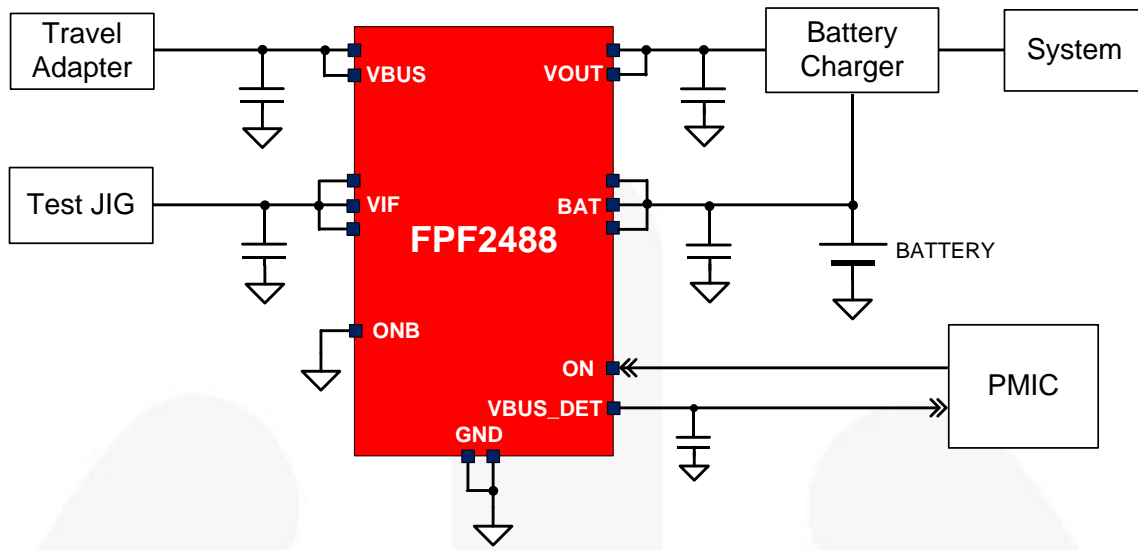

Figure 1. Typical Application

Block Diagram

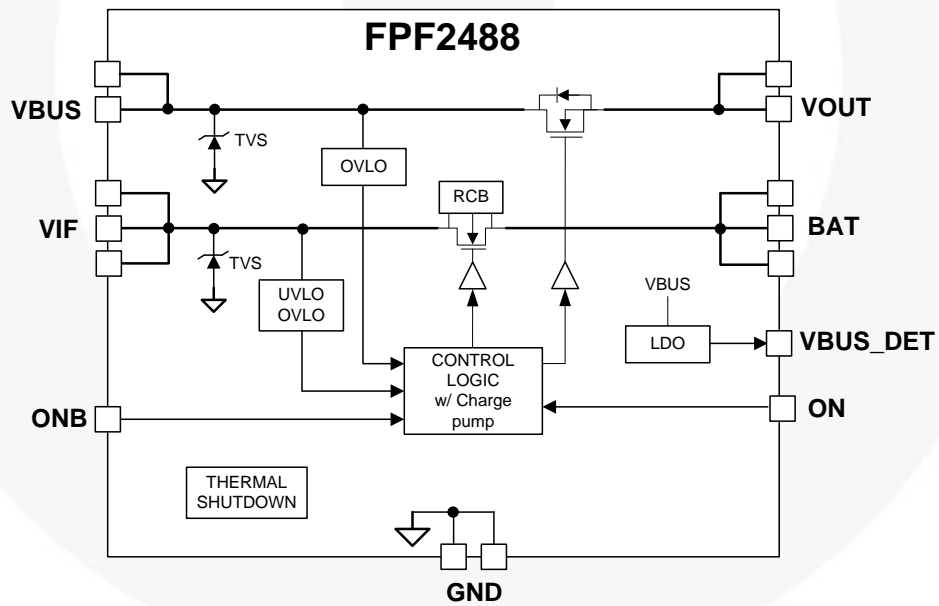

Figure 2. Functional Block Diagram

Pin Configuration

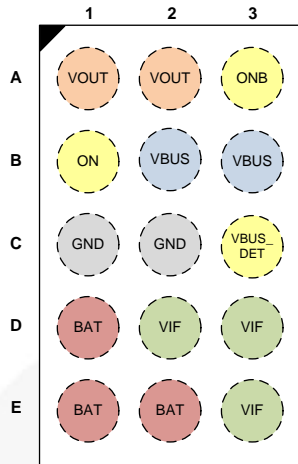

Figure 3. Pin Configuration (Top View)

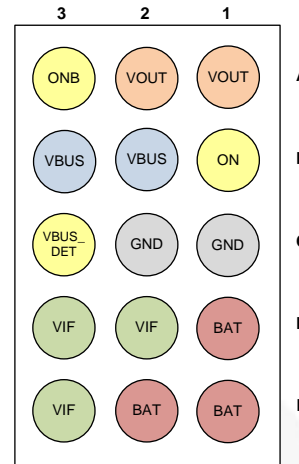

Figure 4. Pin Configuration (Bottom View)

Pin Definitions

| Name | Bump | Type | Description |
|----------------|------------|--------------|---|
| V_{BUS} | B2, B3 | Input/Supply | Switch Input and Device Supply |
| VOUT | A1, A2 | Output | Switch Output to Load |
| V_{IF} | D2, D3, E3 | Input/Supply | Switch Input and Device Supply |
| BAT | D1, E1, E2 | Output | Switch Output to Battery |
| V_{BUS_DET} | C3 | Output | Regulated Output according to V_{BUS} |
| ON | B1 | Input | Active HIGH: V_{IF} path only and when BAT is valid prior to V_{IF} |
| ONB | A3 | Input | Active LOW: V_{BUS} path only |
| GND | C1, C2 | GND | Ground |

Absolute Maximum Ratings

Stresses exceeding the absolute maximum ratings may damage the device. The device may not function or be operable above the recommended operating conditions and stressing the parts to these levels is not recommended. In addition, extended exposure to stresses above the recommended operating conditions may affect device reliability. The absolute maximum ratings are stress ratings only.

| Symbol | Parameter | | Min. | Max. | Unit | |
|--------------------------|---|---|-----------------------------------|-----------------------|------|----|
| V _{BUS} | V _{BUS} to GND & V _{BUS} to V _{OUT} =GND or Float | | -0.3 | 29.0 | V | |
| V _{IF} | V _{IF} to GND | | -2 ⁽¹⁾ | 6 | V | |
| V _{OUT} | V _{OUT} to GND | | -0.3 | V _{IN} + 0.3 | V | |
| BAT | BAT to GND | | -0.3 | V _{IF} + 0.3 | V | |
| V _{BUS_DET} | V _{BUS_DET} to GND | | | 8 | V | |
| V _{ON(B)} | ONB or ON to GND | | | 6 | V | |
| I _{IN_VBUS} | Continuous V _{BUS} Current | | | 2.5 | A | |
| | Peak V _{BUS} Current (5 ms) | | | 5 | A | |
| I _{IN_VIF} | Continuous V _{IF} Current | | | 6 | A | |
| | Peak V _{IF} Current (5 ms) | | | 12 | A | |
| I _{IN_VBUS_DET} | Continuous V _{BUS_DET} Current | | | 1 | mA | |
| t _{PD} | Total Power Dissipation at T _A =25°C | | | 1.54 | W | |
| T _{STG} | Storage Temperature Range | | -65 | +150 | °C | |
| T _J | Maximum Junction Temperature | | | +150 | °C | |
| T _L | Lead Temperature (Soldering, 10 Seconds) | | | +260 | °C | |
| θ _{JA} | Thermal Resistance, Junction-to-Ambient ⁽²⁾ (1-in. ² Pad of 2-oz. Copper) | | | 81 ⁽²⁾ | °C/W | |
| ESD | Electrostatic Discharge Capability | IEC 61000-4-2 System Level ESD | Air Discharge | 15.0 | | kV |
| | | | Contact Discharge | 8.0 | | |
| | | Human Body Model, ANSI/ESDA/JEDEC JS-001-2012 | All Pins | 2 | | |
| | | | Charged Device Model, JESD22-C101 | All Pins | 1 | |
| Surge | | IEC 61000-4-5, Surge Protection | V _{BUS} | ±100 | | V |
| | | | V _{IF} | ±40 | | |

Notes:

1. Pulsed, 50 ms maximum non-repetitive.
2. Measured using 2S2P JEDEC std. PCB.

Recommended Operating Conditions

The Recommended Operating Conditions table defines the conditions for actual device operation. Recommended operating conditions are specified to ensure optimal performance to the datasheet specifications. Fairchild does not recommend exceeding them or designing to Absolute Maximum Ratings.

| Symbol | Parameter | Min. | Max. | Unit |
|------------------------------------|----------------------------------|------|------|------|
| V _{BUS} | Supply Voltage, V _{BUS} | 2.5 | 23.0 | V |
| V _{IF} | Supply Voltage, V _{IF} | 3.1 | 5.5 | V |
| C _{IN} / C _{OUT} | Input and Output Capacitance | 0.1 | | µF |
| C _{VBUS_DET} | Output Capacitance | 0.47 | | µF |
| T _A | Operating Temperature | -40 | +85 | °C |

Electrical Characteristics

Unless otherwise noted, $V_{BUS}=2.5$ to 23 V, $V_{IF}=3.1$ to 5.5 V, $T_A=-40$ to 85°C ; Typical values are at $V_{BUS}=5$ V, $I_{IN} \leq 2$ A, $V_{IF}=4$ V, $C_{IN}=0.1$ μF and $T_A=25^\circ\text{C}$.

| Symbol | Parameter | Conditions | Min. | Typ. | Max. | Unit |
|--|--|---|------|------|------|------------------|
| Basic Operation | | | | | | |
| I_Q | Input Quiescent Current | $V_{BUS}=5$ V, $ONB=0$ V, V_{BUS_DET} =Floating | | 160 | 250 | μA |
| | | $V_{IF}=4$ V | | 100 | 150 | μA |
| I_{IN_Q} | OVLO Supply Current | $V_{BUS}=12$ V, $V_{OUT}=0$ V, V_{BUS_DET} =Floating | | 150 | 205 | μA |
| | | $V_{IF}=5.5$ V, $BAT=0$ V | | 100 | 180 | μA |
| T_{SDN} | Thermal Shutdown ⁽³⁾ | | | 140 | | $^\circ\text{C}$ |
| T_{SDN_HYS} | Thermal Shutdown Hysteresis ⁽³⁾ | | | 20 | | $^\circ\text{C}$ |
| V_{BUS} to V_{OUT} Switch | | | | | | |
| V_{BUS_CLAMP} | Input Clamping Voltage | $I_{IN}=10$ mA | | 35 | | V |
| V_{BUS_OVLO} | Over-Voltage Trip Level | V_{BUS} Rising, $T_A=-40$ to 85°C | 9.9 | 10.0 | 10.1 | V |
| | | V_{BUS} Falling, $T_A=-40$ to 85°C | 9.8 | | | V |
| R_{ON_VBUS} | On-Resistance | $V_{BUS}=5$ V, $I_{OUT}=1$ A, $T_A=25^\circ\text{C}$ | | 33 | 39 | $\text{m}\Omega$ |
| | | $V_{BUS}=9$ V, $I_{OUT}=1$ A, $T_A=25^\circ\text{C}$ | | 33 | 39 | $\text{m}\Omega$ |
| t_{DEB_VBUS} | Debounce Time | Time from $V_{BUS_MIN} < V_{BUS} < V_{BUS_OVLO}$ to $V_{OUT}=0.1 \times V_{BUS}$ | | 15 | | ms |
| t_{START_VBUS} | Soft-Start Time | Time from $V_{BUS}=V_{BUS_MIN}$ to $0.1 \times V_{BUS_DET}$ | | 30 | | ms |
| t_{ON_VBUS} | Switch Turn-On Time | $R_L=100$ Ω , $C_L=22$ μF , V_{OUT} from $0.1 \times V_{BUS}$ to $0.9 \times V_{BUS}$ | | 3 | | ms |
| t_{OFF_VBUS} | Switch Turn-Off Time | $R_L=100$ Ω , No C_L , $V_{BUS} > V_{BUS_OVLO}$ to $V_{OUT}=0.8 \times V_{BUS}$ | | | 150 | ns |
| V_{IF} to BAT Switch | | | | | | |
| V_{IF_CLAMP} | Input Clamping Voltage | $I_{IN}=10$ mA | | 6.4 | | V |
| V_{IF_UVLO} | Under-Voltage Trip Level | V_{IF} Rising, $T_A=-40$ to 85°C | | 2.85 | 3.05 | V |
| | | V_{IF} Falling, $T_A=-40$ to 85°C | | 2.7 | | V |
| V_{IF_OVLO} | Over-Voltage Trip Level | V_{IF} Rising, $T_A=-40$ to 85°C | 5.00 | 5.25 | 5.50 | V |
| | | V_{IF} Falling, $T_A=-40$ to 85°C | 4.8 | | | V |
| R_{ON_VIF} | On-Resistance | $V_{IF}=3.1$ V, $I_{OUT}=1$ A, $T_A=25^\circ\text{C}$ | | 10 | 15 | $\text{m}\Omega$ |
| I_{RCB} | Reverse Current | $V_{IF}=0$ V, $BAT=4.4$ V | | 3 | 7 | μA |
| t_{DEB_VIF} | Debounce Time | Time from $V_{IF_UVLO} < V_{IF} < V_{IF_OVLO}$ to $BAT=0.1 \times V_{IF}$ | | 15 | | ms |
| t_{QUAL_VIF} | Qualification Time | $BAT > V_{IH_BAT}$ First, Time from $ON > V_{IH_ON(B)}$ to BAT Voltage Increase | | 30 | | ms |
| t_{ON_VIF} | Switch Turn-On Time | $R_L=100$ Ω , $C_L=22$ μF , V_{OUT} from $0.1 \times V_{IF}$ to $0.9 \times V_{IF}$ | | 3 | | ms |
| t_{OFF_VIF} | Switch Turn-Off Time | $R_L=100$ Ω , No C_L , $V_{IN} > V_{OVLO}$ to $V_{OUT}=0.8 \times V_{IF}$ | | | 150 | ns |

Note:

- Guaranteed by characterization and design.

Continued on the following page...

Electrical Characteristics

Unless otherwise noted, $V_{BUS}=2.5$ to 23 V, $V_{IF}=3.1$ to 5.5 V, $T_A=-40$ to 85°C ; Typical values are at $V_{BUS}=5$ V, $I_{IN} \leq 2$ A, $V_{IF}=4$ V, $C_{IN}=0.1$ μF and $T_A=25^{\circ}\text{C}$.

| Symbol | Parameter | Conditions | Min. | Typ. | Max. | Unit |
|----------------------------------|--------------------------------|--|------|------|------|---------------|
| V_{BUS_DET} | | | | | | |
| V_{BUS_DET} | V_{BUS_DET} Output Voltage | $V_{BUS}=6.5$ V, $I_{BUS_DET}=0$ mA, $T_A=25^{\circ}\text{C}$ | 6.0 | | 6.5 | V |
| | | $V_{BUS}=15$ V, $I_{BUS_DET}=0$ mA, $T_A=25^{\circ}\text{C}$ | 6.0 | 7.0 | 7.9 | V |
| | | $V_{BUS}=6.5$ V, $I_{BUS_DET}=1$ mA, $T_A=25^{\circ}\text{C}$ | 6.0 | 6.3 | 6.5 | V |
| | | $V_{BUS}=15$ V, $I_{BUS_DET}=1$ mA, $T_A=25^{\circ}\text{C}$ | 6.0 | 7.0 | 7.9 | V |
| Digital Signals | | | | | | |
| $V_{IH_ON(B)}$ | Enable HIGH Voltage | V_{BUS} , V_{IF} Operating Range | 1.2 | | | V |
| $V_{IL_ON(B)}$ | Enable LOW Voltage | V_{BUS} , V_{IF} Operating Range | | | 0.5 | V |
| V_{IH_BAT} | BAT Presence HIGH Voltage | BAT Rising | 2.6 | | | V |
| V_{IL_BAT} | BAT Presence Low Voltage | BAT Falling | | | 1.7 | V |
| $I_{VBUS_DET_LEAK}$ | V_{BUS_DET} Leakage Current | $V_{VBUS_DET}=5$ V, $V_{BUS}=0$ V | | | 1 | μA |
| O_{NB_Leak} | ONB Leakage Current | $V_{BUS}=5$ V, $V_{OUT}=\text{Float}$ | | | 1 | μA |

Timing Diagrams

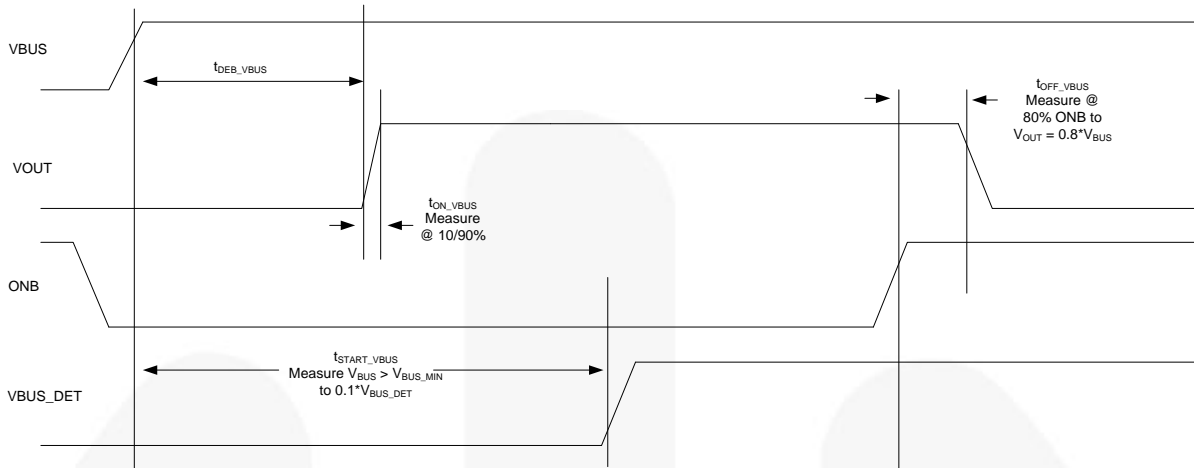

Figure 5. Timing for V_{BUS} Power Up/Down and Normal Operation

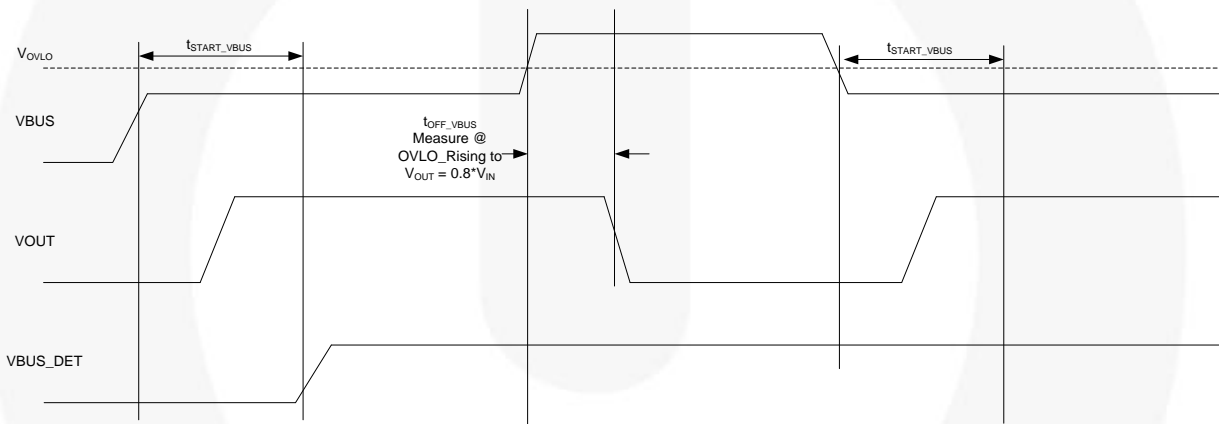

Figure 6. Timing for V_{BUS} OVLO Operation (ONB=LOW)

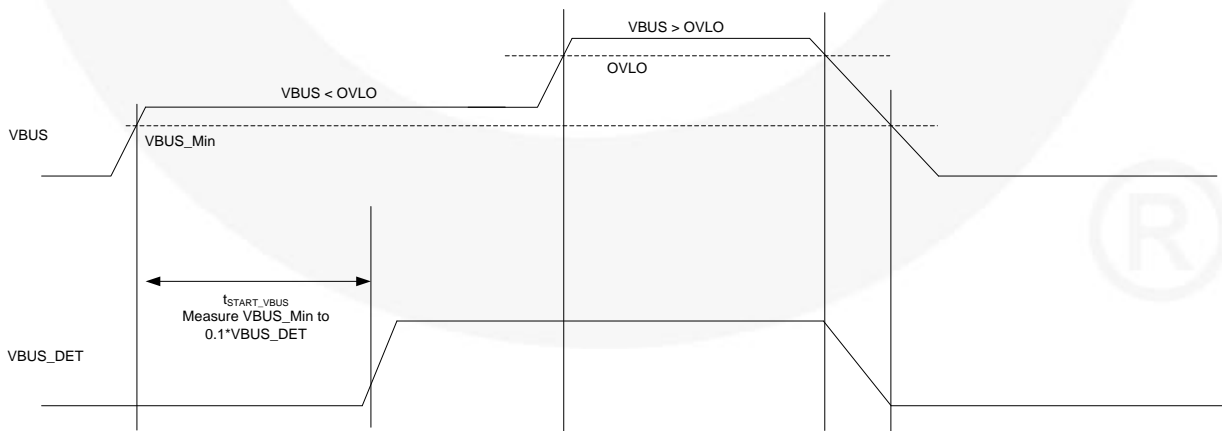

Figure 7. Always ON V_{BUS_DET} Operation (ONB=HIGH)

Timing Diagrams (Continued)

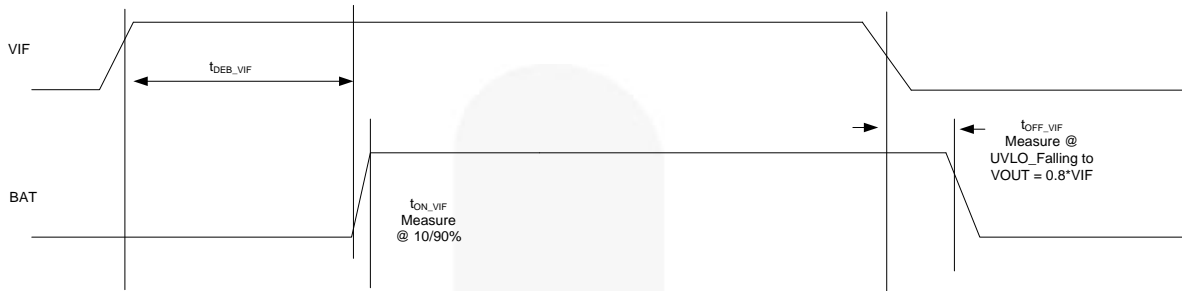

Figure 8. Timing for V_{IF} Power Up/Down and Normal Operation (ON=Don't Care)

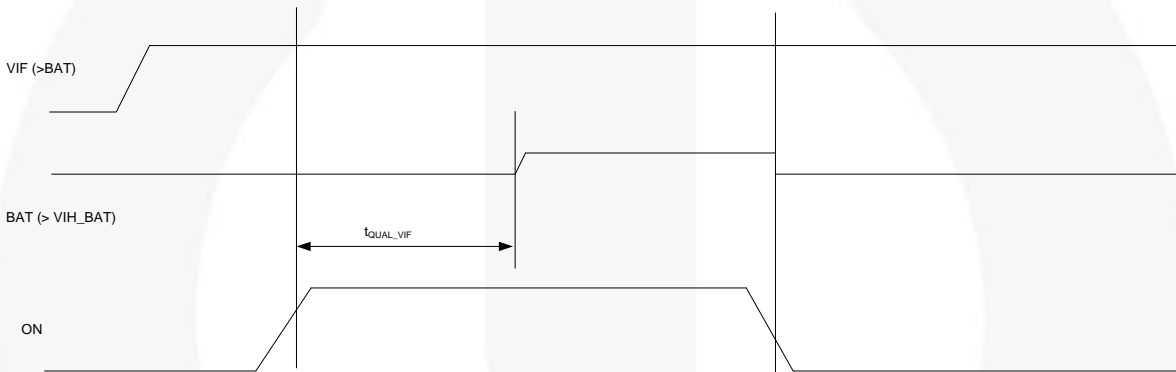

Figure 9. Timing for V_{IF} Power Up/Down and Normal Operation with ON Pin

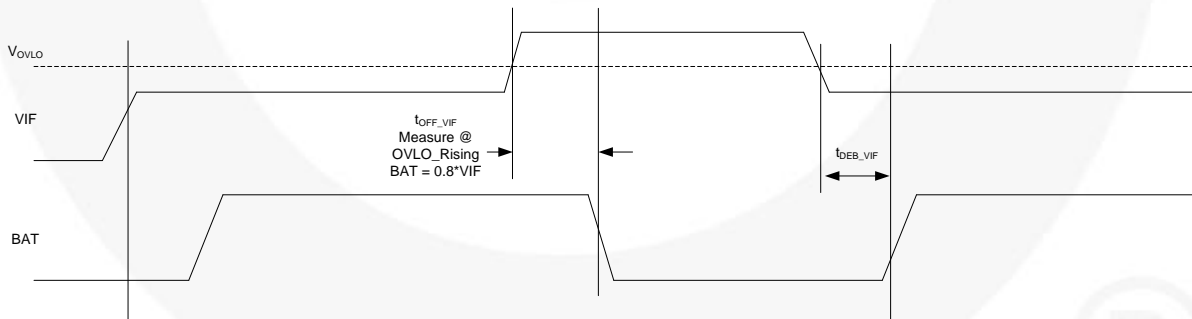

Figure 10. Timing for V_{IF} OVLO Operation (ON=Don't Care)

V_{IF} Turn-On Qualification State Diagram

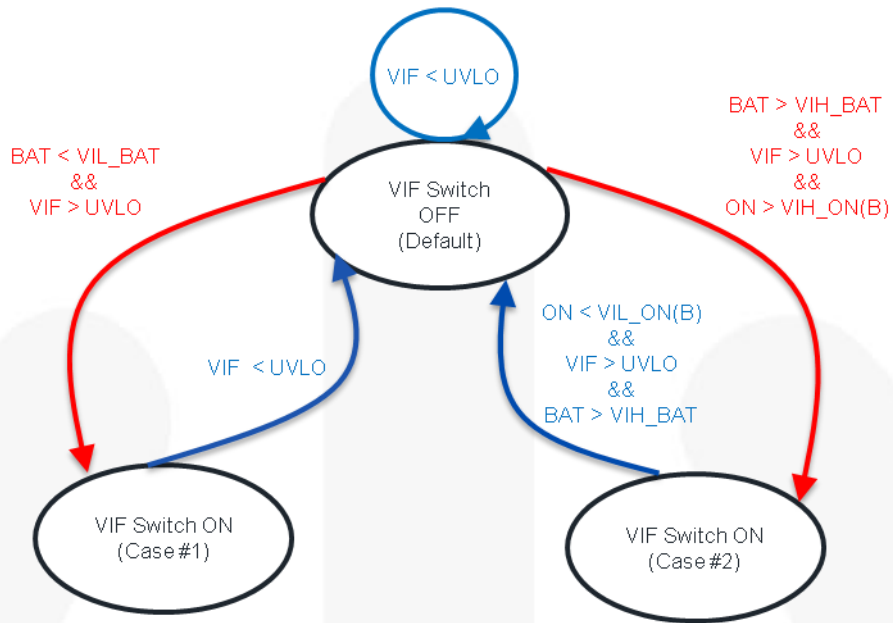

Figure 11. V_{IF} Turn-On Qualification State Diagram

Notes:

- 4. Case #1 is reflecting removable battery system without ON signal.
- 5. Case #2 is reflecting embedded battery system with ON signal.

Product-Specific Dimensions

| D | E | X | Y |
|----------------|----------------|---------------|---------------|
| 2200 μm ±30 μm | 1600 μm ±30 μm | 400 μm ±18 μm | 300 μm ±18 μm |



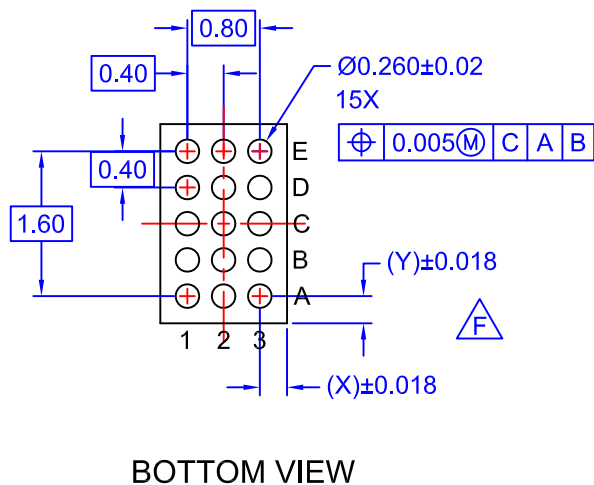
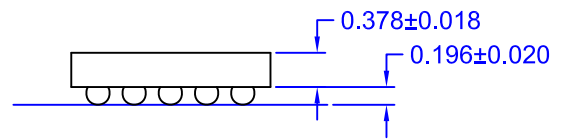
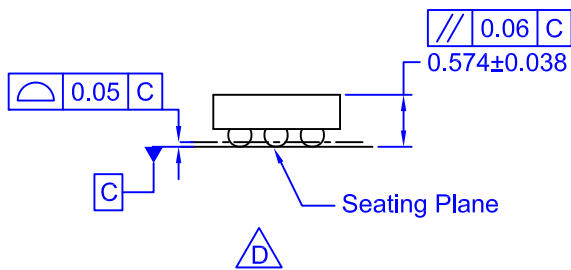
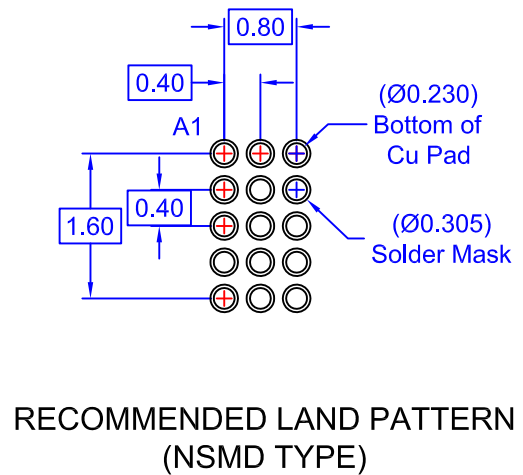
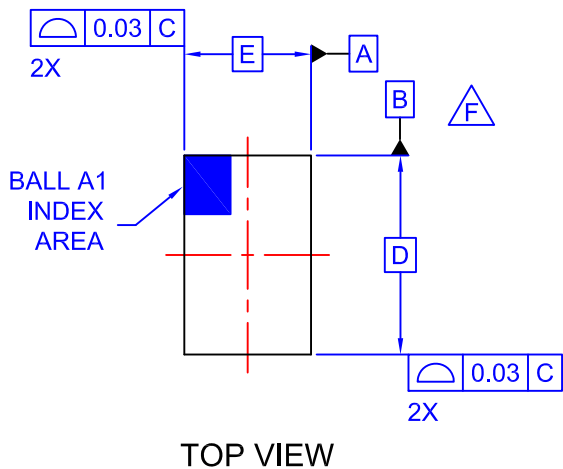

NOTES

- A. NO JEDEC REGISTRATION APPLIES.
- B. DIMENSIONS ARE IN MILLIMETERS.
- C. DIMENSIONS AND TOLERANCE PER ASMEY14.5M, 2009.
- D. DATUM C IS DEFINED BY THE SPHERICAL CROWNS OF THE BALLS.
- E. PACKAGE NOMINAL HEIGHT IS 574 ± 38 MICRONS (536-612 MICRONS).
- F. FOR DIMENSIONS D, E, X, AND Y SEE PRODUCT DATASHEET.
- G. DRAWING FILNAME: MKT-UC015AC REV2.



ON Semiconductor and  are trademarks of Semiconductor Components Industries, LLC dba ON Semiconductor or its subsidiaries in the United States and/or other countries. ON Semiconductor owns the rights to a number of patents, trademarks, copyrights, trade secrets, and other intellectual property. A listing of ON Semiconductor's product/patent coverage may be accessed at www.onsemi.com/site/pdf/Patent-Marking.pdf. ON Semiconductor reserves the right to make changes without further notice to any products herein. ON Semiconductor makes no warranty, representation or guarantee regarding the suitability of its products for any particular purpose, nor does ON Semiconductor assume any liability arising out of the application or use of any product or circuit, and specifically disclaims any and all liability, including without limitation special, consequential or incidental damages. Buyer is responsible for its products and applications using ON Semiconductor products, including compliance with all laws, regulations and safety requirements or standards, regardless of any support or applications information provided by ON Semiconductor. "Typical" parameters which may be provided in ON Semiconductor data sheets and/or specifications can and do vary in different applications and actual performance may vary over time. All operating parameters, including "Typicals" must be validated for each customer application by customer's technical experts. ON Semiconductor does not convey any license under its patent rights nor the rights of others. ON Semiconductor products are not designed, intended, or authorized for use as a critical component in life support systems or any FDA Class 3 medical devices or medical devices with a same or similar classification in a foreign jurisdiction or any devices intended for implantation in the human body. Should Buyer purchase or use ON Semiconductor products for any such unintended or unauthorized application, Buyer shall indemnify and hold ON Semiconductor and its officers, employees, subsidiaries, affiliates, and distributors harmless against all claims, costs, damages, and expenses, and reasonable attorney fees arising out of, directly or indirectly, any claim of personal injury or death associated with such unintended or unauthorized use, even if such claim alleges that ON Semiconductor was negligent regarding the design or manufacture of the part. ON Semiconductor is an Equal Opportunity/Affirmative Action Employer. This literature is subject to all applicable copyright laws and is not for resale in any manner.

PUBLICATION ORDERING INFORMATION

LITERATURE FULFILLMENT:

Literature Distribution Center for ON Semiconductor
19521 E. 32nd Pkwy, Aurora, Colorado 80011 USA
Phone: 303-675-2175 or 800-344-3860 Toll Free USA/Canada
Fax: 303-675-2176 or 800-344-3867 Toll Free USA/Canada
Email: orderlit@onsemi.com

N. American Technical Support: 800-282-9855 Toll Free
USA/Canada
Europe, Middle East and Africa Technical Support:
Phone: 421 33 790 2910
Japan Customer Focus Center
Phone: 81-3-5817-1050

ON Semiconductor Website: www.onsemi.com
Order Literature: <http://www.onsemi.com/orderlit>
For additional information, please contact your local
Sales Representative

Mouser Electronics

Authorized Distributor

Click to View Pricing, Inventory, Delivery & Lifecycle Information:

[ON Semiconductor:](#)

[FPF2488UCX](#)



Компания «ЭлектроПласт» предлагает заключение долгосрочных отношений при поставках импортных электронных компонентов на взаимовыгодных условиях!

Наши преимущества:

- Оперативные поставки широкого спектра электронных компонентов отечественного и импортного производства напрямую от производителей и с крупнейших мировых складов;
- Поставка более 17-ти миллионов наименований электронных компонентов;
- Поставка сложных, дефицитных, либо снятых с производства позиций;
- Оперативные сроки поставки под заказ (от 5 рабочих дней);
- Экспресс доставка в любую точку России;
- Техническая поддержка проекта, помощь в подборе аналогов, поставка прототипов;
- Система менеджмента качества сертифицирована по Международному стандарту ISO 9001;
- Лицензия ФСБ на осуществление работ с использованием сведений, составляющих государственную тайну;
- Поставка специализированных компонентов (Xilinx, Altera, Analog Devices, Intersil, Interpoint, Microsemi, Aeroflex, Peregrine, Syfer, Eurofarad, Texas Instrument, Miteq, Cobham, E2V, MA-COM, Hittite, Mini-Circuits, General Dynamics и др.);

Помимо этого, одним из направлений компании «ЭлектроПласт» является направление «Источники питания». Мы предлагаем Вам помощь Конструкторского отдела:

- Подбор оптимального решения, техническое обоснование при выборе компонента;
- Подбор аналогов;
- Консультации по применению компонента;
- Поставка образцов и прототипов;
- Техническая поддержка проекта;
- Защита от снятия компонента с производства.



Как с нами связаться

Телефон: 8 (812) 309 58 32 (многоканальный)

Факс: 8 (812) 320-02-42

Электронная почта: org@eplast1.ru

Адрес: 198099, г. Санкт-Петербург, ул. Калинина, дом 2, корпус 4, литера А.