

# Chip Beads(SMD) For Power Line

Conformity to RoHS Directive

## MPZ Series MPZ1608 Type

TDK has manufactured MPZ2012 type as EMI countermeasure product for power line, and now maximizes impedance to 600Ω (at 100MHz) and rated current to 1A, while minimizes Rdc under 150mΩ as 1608 type.

### FEATURES

- This type is the best for energy-saving in the low DC resistance.
- The products contain no lead and also support lead-free soldering.
- It is a product conforming to RoHS directive.

### APPLICATIONS

Noise suppression of personal computers, USB/IEEE1394 interfaces, HDDs, CD-ROMs, DVDs, DSCs, LCD panels, cellular phones, etc.

### PRODUCT IDENTIFICATION

MPZ 1608 S 221 A T  
(1) (2) (3) (4) (5) (6)

- (1) Series name
- (2) Dimensions L×W
- (3) Material code
- (4) Nominal impedance  
221: 220Ω at 100MHz
- (5) Characteristic type
- (6) Packaging style  
T: Taping

### RECOMMENDED SOLDERING CONDITION REFLOW SOLDERING

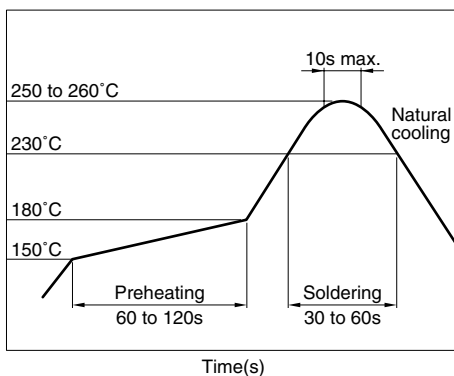

### SHAPES AND DIMENSIONS/RECOMMENDED PC BOARD PATTERN

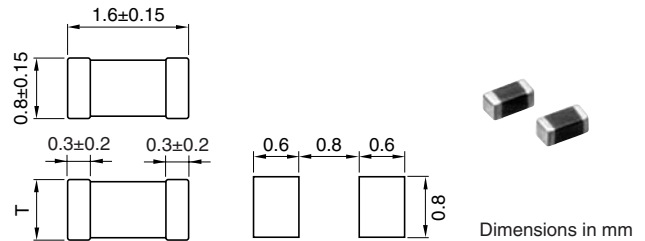

Thickness(T)	Weight
0.6±0.15mm	3mg
0.8±0.15mm	4mg

### TEMPERATURE RANGES

Operating/storage	-55 to +125°C
-------------------	---------------

### PACKAGING STYLE AND QUANTITIES

Packaging style	Quantity
Taping	4000 pieces/reel

### HANDLING AND PRECAUTIONS

- Before soldering, be sure to preheat components. The preheating temperature should be set so that the temperature difference between the solder temperature and product temperature does not exceed 150°C.
- After mounting components onto the printed circuit board, do not apply stress through board bending or mishandling.
- The inductance value may change due to magnetic saturation if the current exceeds the rated maximum.
- Do not expose the inductors to stray magnetic fields.
- Avoid static electricity discharge during handling.
- When hand soldering, apply the soldering iron to the printed circuit board only. Temperature of the iron tip should not exceed 350°C. Soldering time should not exceed 3 seconds.

• Conformity to RoHS Directive: This means that, in conformity with EU Directive 2002/95/EC, lead, cadmium, mercury, hexavalent chromium, and specific bromine-based flame retardants, PBB and PBDE, have not been used, except for exempted applications.

• Please contact our Sales office when your application are considered the following:  
The device's failure or malfunction may directly endanger human life (e.g. application for automobile/aircraft/medical/nuclear power devices, etc.)

• All specifications are subject to change without notice.

### ELECTRICAL CHARACTERISTICS

Part No.	Impedance ( $\Omega$ )[100MHz] <sup>*1</sup>	DC resistance ( $\Omega$ )max.	Rated current <sup>*2</sup> (A)max.	Thickness T(mm)
MPZ1608S300A	30 $\pm$ 10 $\Omega$	0.01	5	0.6
MPZ1608S600A	60 $\pm$ 25%	0.02	3.5	0.6
MPZ1608S101A	100 $\pm$ 25%	0.03	3	0.6
MPZ1608S221A	220 $\pm$ 25%	0.05	2	0.8
MPZ1608R391A	390 $\pm$ 25%	0.12	1.2	0.8
MPZ1608S601A	600 $\pm$ 25%	0.15	1	0.8
MPZ1608Y600B	60 $\pm$ 25%	0.03	2.3	0.8
MPZ1608Y101B	100 $\pm$ 25%	0.05	2.0	0.8
MPZ1608Y151B	150 $\pm$ 25%	0.07	1.8	0.8
MPZ1608D300B	30 $\pm$ 10 $\Omega$	0.07	1.8	0.8
MPZ1608D600B	60 $\pm$ 25%	0.12	1.2	0.8
MPZ1608D101B	100 $\pm$ 25%	0.15	1.0	0.8

\*1 Test equipment: E4991A or equivalent

Test tool: 16192A or equivalent

\*2 Please refer to the graph of RATED CURRENT vs. TEMPERATURE CHARACTERISTICS(DERATING) about the rating current at 85°C or more in temperature of the product.

### RATED CURRENT vs. TEMPERATURE CHARACTERISTICS (DERATING)

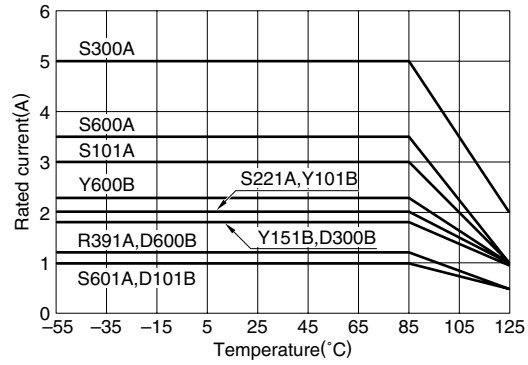

### TYPICAL ELECTRICAL CHARACTERISTICS

#### Z, X, R vs. FREQUENCY CHARACTERISTICS

MPZ1608S300A

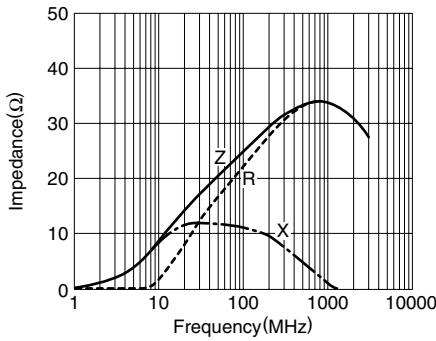

MPZ1608S600A

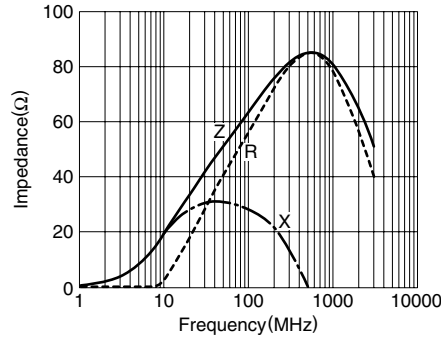

MPZ1608S101A

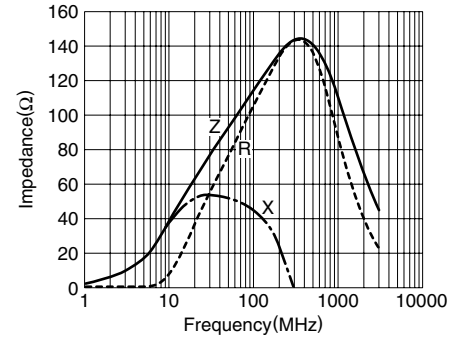

MPZ1608S221A

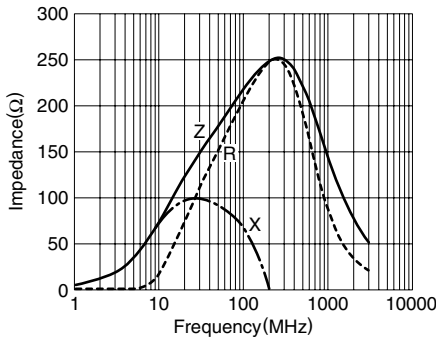

MPZ1608R391A

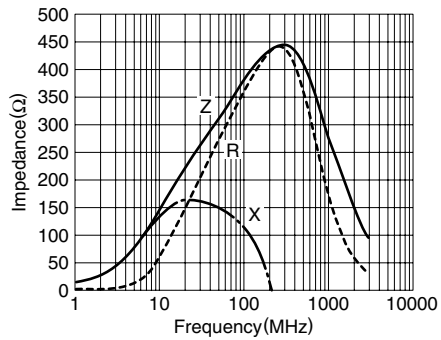

MPZ1608S601A

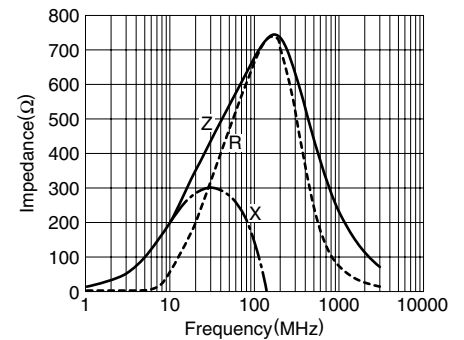

MPZ1608Y600B

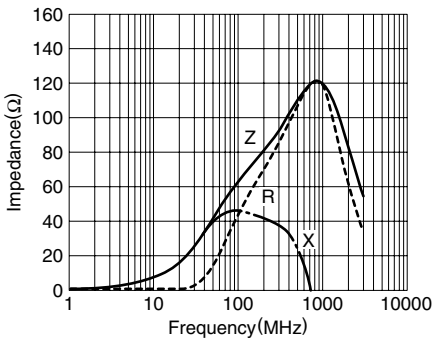

MPZ1608Y101B

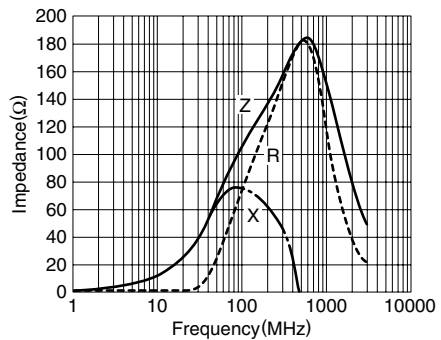

MPZ1608Y151B

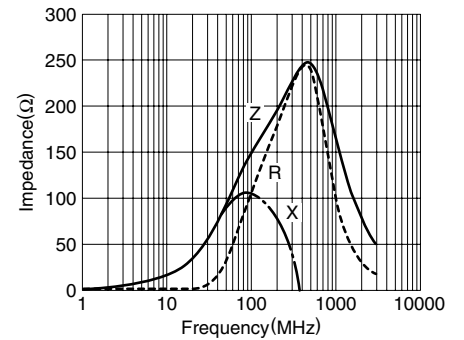

• All specifications are subject to change without notice.

**TYPICAL ELECTRICAL CHARACTERISTICS**  
**Z, X, R vs. FREQUENCY CHARACTERISTICS**  
**MPZ1608D300B**

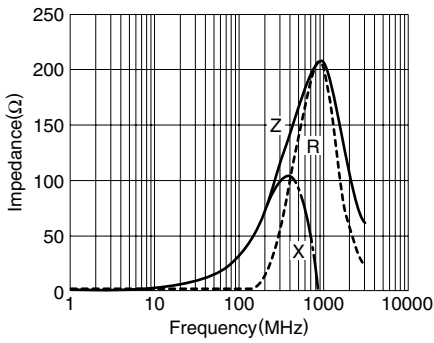

**MPZ1608D600B**

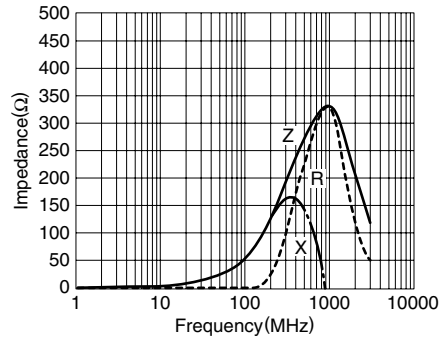

**MPZ1608D101B**

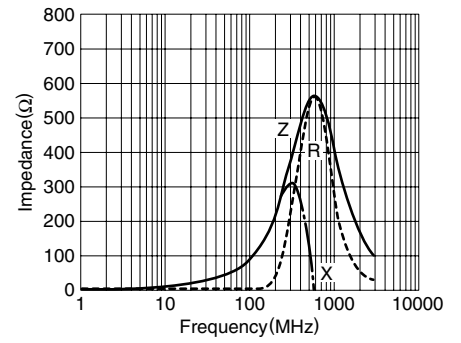

**PACKAGING STYLES**  
**REEL DIMENSIONS**

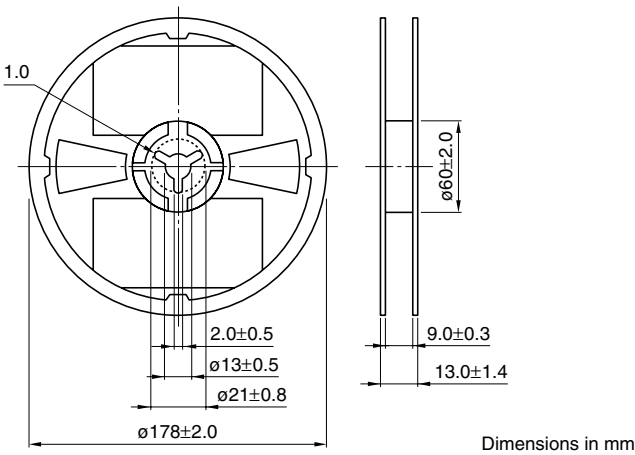

**TAPE DIMENSIONS**

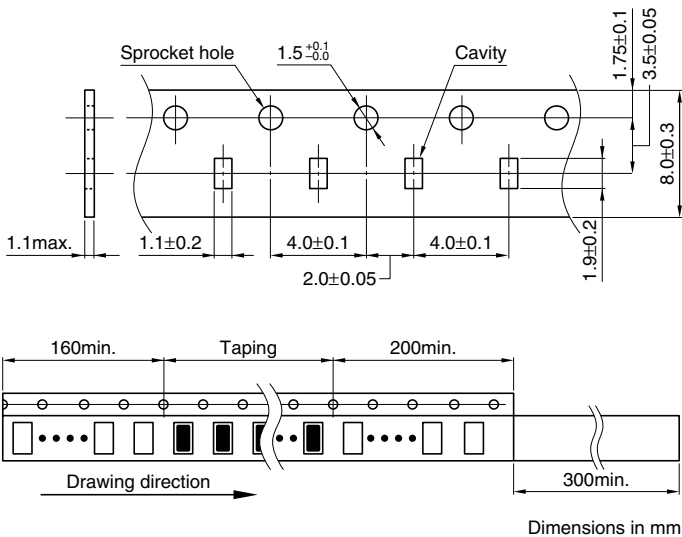

• All specifications are subject to change without notice.



Компания «ЭлектроПласт» предлагает заключение долгосрочных отношений при поставках импортных электронных компонентов на взаимовыгодных условиях!

Наши преимущества:

- Оперативные поставки широкого спектра электронных компонентов отечественного и импортного производства напрямую от производителей и с крупнейших мировых складов;
- Поставка более 17-ти миллионов наименований электронных компонентов;
- Поставка сложных, дефицитных, либо снятых с производства позиций;
- Оперативные сроки поставки под заказ (от 5 рабочих дней);
- Экспресс доставка в любую точку России;
- Техническая поддержка проекта, помощь в подборе аналогов, поставка прототипов;
- Система менеджмента качества сертифицирована по Международному стандарту ISO 9001;
- Лицензия ФСБ на осуществление работ с использованием сведений, составляющих государственную тайну;
- Поставка специализированных компонентов (Xilinx, Altera, Analog Devices, Intersil, Interpoint, Microsemi, Aeroflex, Peregrine, Syfer, Eurofarad, Texas Instrument, Miteq, Cobham, E2V, MA-COM, Hittite, Mini-Circuits, General Dynamics и др.);

Помимо этого, одним из направлений компании «ЭлектроПласт» является направление «Источники питания». Мы предлагаем Вам помощь Конструкторского отдела:

- Подбор оптимального решения, техническое обоснование при выборе компонента;
- Подбор аналогов;
- Консультации по применению компонента;
- Поставка образцов и прототипов;
- Техническая поддержка проекта;
- Защита от снятия компонента с производства.



#### Как с нами связаться

**Телефон:** 8 (812) 309 58 32 (многоканальный)

**Факс:** 8 (812) 320-02-42

**Электронная почта:** [org@eplast1.ru](mailto:org@eplast1.ru)

**Адрес:** 198099, г. Санкт-Петербург, ул. Калинина, дом 2, корпус 4, литера А.