



# Low-Power, Quad, 10-Bit Voltage-Output DAC with Serial Interface

MAX5250

## General Description

The +5V MAX5250 combines four low-power, voltage-output, 10-bit digital-to-analog converters (DACs) and four precision output amplifiers in a space-saving, 20-pin package. In addition to the four voltage outputs, each amplifier's negative input is also available to the user. This facilitates specific gain configurations, remote sensing, and high output drive capacity, making the MAX5250 ideal for industrial-process-control applications. Other features include software shutdown, hardware shutdown lockout, an active-low reset that clears all registers and DACs to zero, a user-programmable logic output, and a serial-data output.

Each DAC has a double-buffered input organized as an input register followed by a DAC register. A 16-bit serial word loads data into each input/DAC register. The 3-wire serial interface is compatible with SPI™/QSPI™ and MICROWIRE™. It allows the input and DAC registers to be updated independently or simultaneously with a single software command. All logic inputs are TTL/CMOS-logic compatible.

## Applications

Digital Offset and Gain Adjustment  
 Microprocessor-Controlled Systems  
 Industrial Process Controls  
 Automatic Test Equipment  
 Remote Industrial Controls  
 Motion Control

## Features

- ◆ Four 10-Bit DACs with Configurable Output Amplifiers
- ◆ +5V Single-Supply Operation
- ◆ Low Supply Current: 0.85mA Normal Operation  
10µA Shutdown Mode
- ◆ Available in 20-Pin SSOP and DIP Packages
- ◆ Power-On Reset Clears all Registers and DACs to Zero
- ◆ SPI/QSPI and MICROWIRE Compatible
- ◆ Simultaneous or Independent Control of DACs through 3-Wire Serial Interface
- ◆ User-Programmable Digital Output
- ◆ Schmitt-Trigger Inputs for Direct Optocoupler Interface
- ◆ 12-Bit Upgrade Available: MAX525

## Ordering Information

PART	TEMP RANGE	PIN-PACKAGE	INL (LSB)
MAX5250ACPP	0°C to +70°C	20 Plastic DIP	±1/2
MAX5250BCPP	0°C to +70°C	20 Plastic DIP	±1
MAX5250ACAP	0°C to +70°C	20 SSOP	±1/2
MAX5250BCAP	0°C to +70°C	20 SSOP	±1

Ordering Information continued on last page.

Pin Configuration appears at end of data sheet.

## Functional Diagram



SPI and QSPI are trademarks of Motorola, Inc. MICROWIRE is a trademark of National Semiconductor Corp.



Maxim Integrated Products 1

**For pricing, delivery, and ordering information, please contact Maxim/Dallas Direct! at 1-888-629-4642, or visit Maxim's website at [www.maxim-ic.com](http://www.maxim-ic.com).**

# Low-Power, Quad, 10-Bit Voltage-Output DAC with Serial Interface

## ABSOLUTE MAXIMUM RATINGS

V <sub>DD</sub> to AGND	-0.3V to +6V	Continuous Power Dissipation (T <sub>A</sub> = +70°C)
V <sub>DD</sub> to DGND	-0.3V to +6V	Plastic DIP (derate 8.00mW/°C above +70°C)
AGND to DGND	±0.3V	SSOP (derate 8.00mW/°C above +70°C)
REFAB, REFCD to AGND	-0.3V to (V <sub>DD</sub> + 0.3V)	CERDIP (derate 11.11mW/°C above +70°C)
OUT <sub>-</sub> , FB <sub>-</sub> to AGND	-0.3V to (V <sub>DD</sub> + 0.3V)	Operating Temperature Ranges
Digital Inputs to DGND	-0.3V to +6V	MAX5250_C_P
DOUT, UPO to DGND	-0.3V to (V <sub>DD</sub> + 0.3V)	MAX5250_E_P
Continuous Current into Any Pin	±20mA	MAX5250BMJP
		Storage Temperature Range
		Lead Temperature (soldering, 10s)

Stresses beyond those listed under "Absolute Maximum Ratings" may cause permanent damage to the device. These are stress ratings only, and functional operation of the device at these or any other conditions beyond those indicated in the operational sections of the specifications is not implied. Exposure to absolute maximum rating conditions for extended periods may affect device reliability.

## ELECTRICAL CHARACTERISTICS

(V<sub>DD</sub> = +5V ±10%, AGND = DGND = 0V, REFAB = REFCD = 2.5V, R<sub>L</sub> = 5kΩ, C<sub>L</sub> = 100pF, T<sub>A</sub> = T<sub>MIN</sub> to T<sub>MAX</sub>, unless otherwise noted. Typical values are at T<sub>A</sub> = +25°C. Output buffer connected in unity-gain configuration (Figure 9).)

PARAMETER	SYMBOL	CONDITIONS	MIN	TYP	MAX	UNITS
<b>STATIC PERFORMANCE—ANALOG SECTION</b>						
Resolution	N		10			Bits
Integral Nonlinearity (Note 1)	INL	MAX5250A		±0.25	±0.5	LSB
		MAX5250B			±1.0	
Differential Nonlinearity	DNL	Guaranteed monotonic			±1.0	LSB
Offset Error	V <sub>OS</sub>				±6.0	mV
Offset-Error Tempco				6		ppm/°C
Gain Error	GE	(Note 1)			±1.0	LSB
Gain-Error Tempco				1		ppm/°C
Power-Supply Rejection Ratio	PSRR	4.5V ≤ V <sub>DD</sub> ≤ 5.5V		100	800	μV/V
<b>REFERENCE INPUT</b>						
Reference Input Range	V <sub>REF</sub>		0		V <sub>DD</sub> - 1.4	V
Reference Input Resistance	R <sub>REF</sub>	Code dependent, minimum at code 554 hex	8			kΩ
<b>MULTIPLYING-MODE PERFORMANCE</b>						
Reference -3dB Bandwidth		V <sub>REF</sub> = 0.67V <sub>P-P</sub>		650		kHz
Reference Feedthrough		Input code = all 0s, V <sub>REF</sub> = 3.6V <sub>P-P</sub> at 1kHz		-84		dB
Signal-to-Noise Plus Distortion Ratio	SINAD	V <sub>REF</sub> = 1V <sub>P-P</sub> at 25kHz, code = full scale		72		dB

# Low-Power, Quad, 10-Bit Voltage-Output DAC with Serial Interface

MAX5250

## ELECTRICAL CHARACTERISTICS (continued)

( $V_{DD} = +5V \pm 10\%$ ,  $AGND = DGND = 0V$ ,  $REFAB = REFCD = 2.5V$ ,  $R_L = 5k\Omega$ ,  $C_L = 100pF$ ,  $T_A = T_{MIN}$  to  $T_{MAX}$ , unless otherwise noted. Typical values are at  $T_A = +25^\circ C$ . Output buffer connected in unity-gain configuration (Figure 9).)

PARAMETER	SYMBOL	CONDITIONS	MIN	TYP	MAX	UNITS
<b>DIGITAL INPUTS</b>						
Input High Voltage	$V_{IH}$		2.4			V
Input Low Voltage	$V_{IL}$				0.8	V
Input Leakage Current	$I_{IN}$	$V_{IN} = 0V$ or $V_{DD}$		0.01	$\pm 1.0$	$\mu A$
Input Capacitance	$C_{IN}$			8		pF
<b>DIGITAL OUTPUTS</b>						
Output High Voltage	$V_{OH}$	$I_{SOURCE} = 2mA$	$V_{DD} - 0.5$			V
Output Low Voltage	$V_{OL}$	$I_{SINK} = 2mA$		0.13	0.4	V
<b>DYNAMIC PERFORMANCE</b>						
Voltage Output Slew Rate	SR			0.6		V/ $\mu s$
Output Settling Time		$T_o \pm 1/2LSB$ , $V_{STEP} = 2.5V$		10		$\mu s$
Output Voltage Swing		Rail-to-Rail® (Note 2)		0 to $V_{DD}$		V
Current into FB <sub>-</sub>				0	0.1	$\mu A$
OUT <sub>-</sub> Leakage Current in Shutdown		$R_L = \infty$		0.01	$\pm 1$	$\mu A$
Start-Up Time Exiting Shutdown Mode				15		$\mu s$
Digital Feedthrough		$\overline{CS} = V_{DD}$ , $DIN = 100kHz$		5		nV-s
Digital Crosstalk				5		nV-s
<b>POWER SUPPLIES</b>						
Supply Voltage	$V_{DD}$		4.5		5.5	V
Supply Current	$I_{DD}$	(Note 3)		0.85	0.98	mA
Supply Current in Shutdown		(Note 3)		10	20	$\mu A$
Reference Current in Shutdown				0.01	$\pm 1$	$\mu A$

**Note 1:** Guaranteed from code 3 to code 1023 in unity-gain configuration.

**Note 2:** Accuracy is better than 1LSB for  $V_{OUT} = 6mV$  to  $V_{DD} - 60mV$ , guaranteed by a power-supply rejection test at the end points.

**Note 3:**  $R_L = \infty$ , digital inputs at DGND or  $V_{DD}$ .

*Rail-to-Rail is a registered trademark of Nippon Motorola, Inc.*

# Low-Power, Quad, 10-Bit Voltage-Output DAC with Serial Interface

## ELECTRICAL CHARACTERISTICS (continued)

( $V_{DD} = +5V \pm 10\%$ ,  $AGND = DGND = 0V$ ,  $REFAB = REFCD = 2.5V$ ,  $R_L = 5k\Omega$ ,  $C_L = 100pF$ ,  $T_A = T_{MIN}$  to  $T_{MAX}$ , unless otherwise noted. Typical values are at  $T_A = +25^\circ C$ . Output buffer connected in unity-gain configuration (Figure 9).)

PARAMETER	SYMBOL	CONDITIONS	MIN	TYP	MAX	UNITS
<b>TIMING CHARACTERISTICS</b> (Figure 6)						
SCLK Clock Period	t <sub>CP</sub>		100			ns
SCLK Pulse Width High	t <sub>CH</sub>		40			ns
SCLK Pulse Width Low	t <sub>CL</sub>		40			ns
$\overline{CS}$ Fall to SCLK Rise Setup Time	t <sub>CSS</sub>		40			ns
SCLK Raise to $\overline{CS}$ Rise Hold Time	t <sub>CSH</sub>		0			ns
DIN Setup Time	t <sub>DS</sub>		40			ns
DIN Hold Time	t <sub>DH</sub>		0			ns
SCLK Rise to DOUT Valid Propagation Delay	t <sub>D01</sub>	$C_{LOAD} = 200pF$			80	ns
SCLK Fall to DOUT Valid Propagation Delay	t <sub>D02</sub>	$C_{LOAD} = 200pF$			80	ns
SCLK Rise to $\overline{CS}$ Fall Delay	t <sub>CS0</sub>		40			ns
$\overline{CS}$ Rise to SCLK Rise Hold Time	t <sub>CS1</sub>		40			ns
$\overline{CS}$ Pulse Width High	t <sub>CSW</sub>		100			ns

## Typical Operating Characteristics

( $V_{DD} = +5V$ ,  $T_A = +25^\circ C$ , unless otherwise noted.)

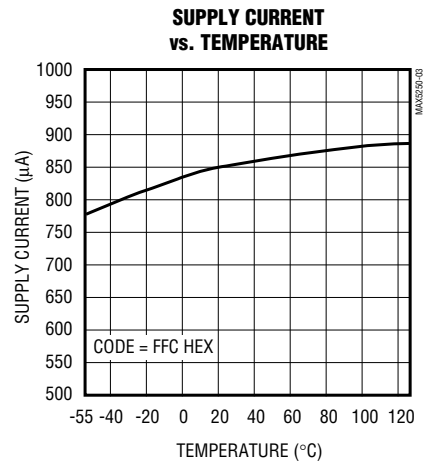
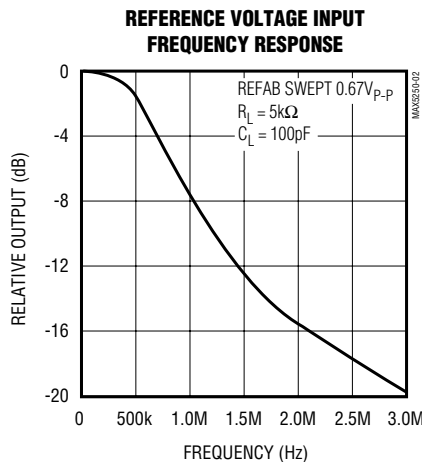

# Low-Power, Quad, 10-Bit Voltage-Output DAC with Serial Interface

MAX5250

## Typical Operating Characteristics (continued)

( $V_{DD} = +5V$ ,  $T_A = +25^\circ C$ , unless otherwise noted.)

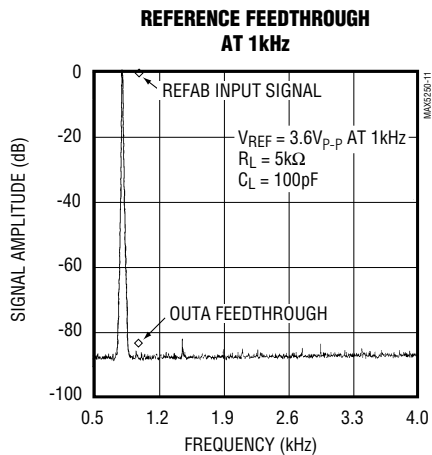
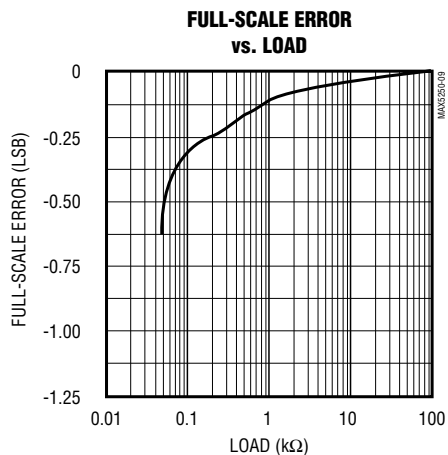
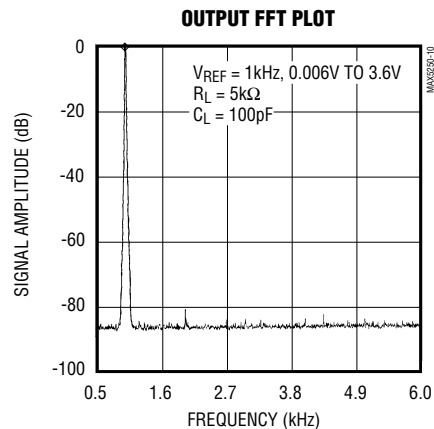
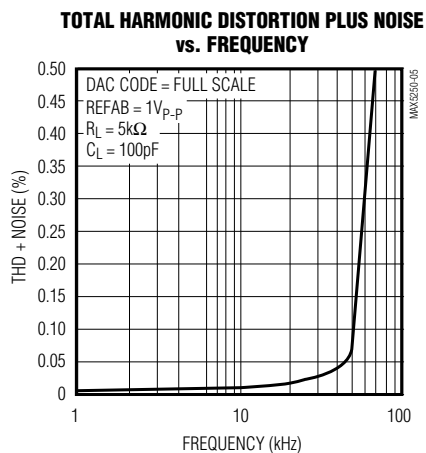
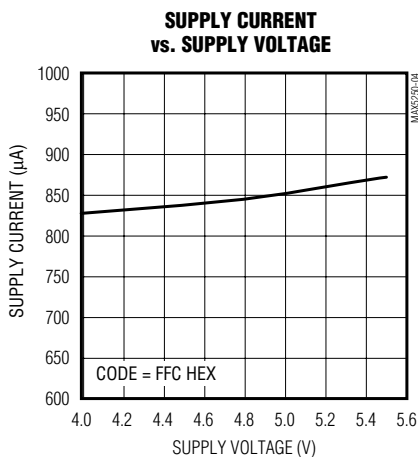

# Low-Power, Quad, 10-Bit Voltage-Output DAC with Serial Interface

## Typical Operating Characteristics (continued)

( $V_{DD} = +5V$ ,  $V_{REF} = 2.5V$ ,  $R_L = 5k\Omega$ ,  $C_L = 100pF$ ,  $T_A = +25^\circ C$ , unless otherwise noted.)

**MAJOR-CARRY TRANSITION**



10µs/div

**DIGITAL FEEDTHROUGH (SCLK = 100kHz)**



2µs/div

$\overline{CS} = \overline{PDL} = \overline{CL} = 5V$ ,  $DIN = 0V$   
DAC A CODE SET TO 800 HEX

**ANALOG CROSSTALK**



10µs/div

DAC A CODE SWITCHING FROM 00C HEX TO FFC HEX  
DAC B CODE SET TO 800 HEX

**DYNAMIC RESPONSE**



10µs/div

SWITCHING FROM CODE 000 HEX TO FB4 HEX  
OUTPUT AMPLIFIER GAIN = +2

# Low-Power, Quad, 10-Bit Voltage-Output DAC with Serial Interface

## Pin Description

**MAX5250**

PIN	NAME	FUNCTION
1	AGND	Analog Ground
2	FBA	DAC A Output Amplifier Feedback
3	OUTA	DAC A Output Voltage
4	OUTB	DAC B Output Voltage
5	FBB	DAC B Output Amplifier Feedback
6	REFAB	Reference Voltage Input for DAC A and DAC B
7	$\overline{CL}$	Clear All DACs and Registers. Resets all outputs (OUT_, UPO, DOUT) to 0, active low.
8	$\overline{CS}$	Chip-Select Input. Active low.
9	DIN	Serial-Data Input
10	SCLK	Serial-Clock Input
11	DGND	Digital Ground
12	DOUT	Serial-Data Output
13	UPO	User-Programmable Logic Output
14	$\overline{PDL}$	Power-Down Lockout. Active low. Locks out software shutdown if low.
15	REFCD	Reference Voltage Input for DAC C and DAC D
16	FBC	DAC C Output Amplifier Feedback
17	OUTC	DAC C Output Voltage
18	OUTD	DAC D Output Voltage
19	FBD	DAC D Output Amplifier Feedback
20	VDD	Positive Power Supply

# Low-Power, Quad, 10-Bit Voltage-Output DAC with Serial Interface

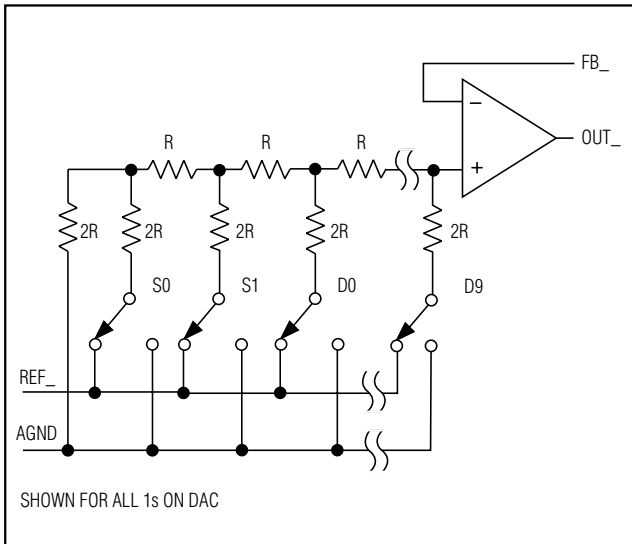

Figure 1. Simplified DAC Circuit Diagram

## Detailed Description

The MAX5250 contains four 10-bit, voltage-output digital-to-analog converters (DACs) that are easily addressed using a simple 3-wire serial interface. It includes a 16-bit data-in/data-out shift register, and each DAC has a doubled-buffered input composed of an input register and a DAC register (see *Functional Diagram*). In addition to the four voltage outputs, each amplifier's negative input is available to the user.

The DACs are inverted R-2R ladder networks that convert a digital input (10 data bits plus 2 sub-bits) into equivalent analog output voltages in proportion to the applied reference voltage inputs. DACs A and B share the REFAB reference input, while DACs C and D share the REFCD reference input. The two reference inputs allow different full-scale output voltage ranges for each pair of DACs. Figure 1 shows a simplified circuit diagram of one of the four DACs.

### Reference Inputs

The two reference inputs accept positive DC and AC signals. The voltage at each reference input sets the full-scale output voltage for its two corresponding DACs. The reference input voltage range is 0V to ( $V_{DD} - 1.4V$ ). The output voltages ( $V_{OUT\_}$ ) are represented by a digitally programmable voltage source as:

$$V_{OUT\_} = (V_{REF} \times NB / 1024) \times \text{Gain}$$

where NB is the numeric value of the DAC's binary input code (0 to 1023),  $V_{REF}$  is the reference voltage, and Gain is the externally set voltage gain.

The impedance at each reference input is code dependent, ranging from a low value of  $10k\Omega$  when both DACs connected to the reference have an input code of 554 hex, to a high value exceeding several giga ohms (leakage currents) with an input code of 000 hex. Because the input impedance at the reference pins is code dependent, load regulation of the reference source is important.

The REFAB and REFCD reference inputs have a  $10k\Omega$  guaranteed minimum input impedance. When the two reference inputs are driven from the same source, the effective minimum impedance is  $5k\Omega$ . A voltage reference with a load regulation of 6ppm/mA, such as the MAX873, would typically deviate by 0.006LSB (0.015LSB worst case) when driving both MAX5250 reference inputs simultaneously at 2.5V. Driving the REFAB and REFCD pins separately improves reference accuracy.

In shutdown mode, the MAX5250's REFAB and REFCD inputs enter a high-impedance state with a typical input leakage current of  $0.01\mu A$ .

The reference input capacitance is also code dependent and typically ranges from 20pF with an input code of all 0s to 100pF at full scale.

### Output Amplifiers

All MAX5250 DAC outputs are internally buffered by precision amplifiers with a typical slew rate of  $0.6V/\mu s$ . Access to each output amplifier's inverting input provides the user greater flexibility in output gain setting/signal conditioning (see the *Applications Information* section).

With a full-scale transition at the MAX5250 output, the typical settling time to  $\pm 1/2LSB$  is  $10\mu s$  when loaded with  $5k\Omega$  in parallel with 100pF (loads less than  $2k\Omega$  degrade performance).

The MAX5250 output amplifier's output dynamic responses and settling performances are shown in the *Typical Operating Characteristics*.

### Power-Down Mode

The MAX5250 features a software-programmable shutdown that reduces supply current to a typical value of  $10\mu A$ . The power-down lockout pin (PDL) must be high to enable shutdown mode. Writing 1100XXXXXXXXXXXX as the input-control word puts the MAX5250 in power-down mode (Table 1).



# Low-Power, Quad, 10-Bit Voltage-Output DAC with Serial Interface

In power-down mode, the MAX5250 output amplifiers and the reference inputs enter a high-impedance state. The serial interface remains active. Data in the input registers is retained in power-down, allowing the MAX5250 to recall the output states prior to entering shutdown. Start up from power-down either by recalling the previous configuration or by updating the DACs with new data. When powering up the device or bringing it out of shutdown, allow 15µs for the outputs to stabilize.

### Serial-Interface Configurations

The MAX5250's 3-wire serial interface is compatible with both MICROWIRE (Figure 2) and SPI/QSPI (Figure 3). The serial input word consists of two address bits and two control bits followed by 10+2 data bits (MSB first), as shown in Figure 4. The 4-bit address/control code determines the MAX5250's response outlined in Table 1. The connection between DOUT and the serial-interface port is not necessary, but may be used for data echo. Data held in the MAX5250's shift register can be shifted out of DOUT and returned to the microprocessor (µP) for data verification.

The MAX5250's digital inputs are double buffered. Depending on the command issued through the serial interface, the input register(s) can be loaded without affecting the DAC register(s), the DAC register(s) can be loaded directly, or all four DAC registers can be updated simultaneously from the input registers (Table 1).

### Serial-Interface Description

The MAX5250 requires 16 bits of serial data. Table 1 lists the serial-interface programming commands. For certain commands, the 10+2 data bits are "don't cares." Data is sent MSB first and can be sent in two 8-bit packets or one 16-bit word (CS must remain low until 16 bits are transferred). The serial data is composed of two DAC address bits (A1, A0) and two control bits (C1, C0), followed by the 10+2 data bits D9...D0, S1, S0 (Figure 4). Set both sub-bits (S1, S0) to zero. The 4-bit address/control code determines:

- The register(s) to be updated
- The clock edge on which data is to be clocked out through the serial-data output (DOUT)
- The state of the user-programmable logic output (UPO)
- If the part is to go into shutdown mode (assuming PDL is high)
- How the part is configured when coming out of shutdown mode.



Figure 2. Connections for Microwire



Figure 3. Connections for SPI/QSPI



Figure 4. Serial-Data Format

# Low-Power, Quad, 10-Bit Voltage-Output DAC with Serial Interface

**Table 1. Serial-Interface Programming Commands**

16-BIT SERIAL WORD						FUNCTION
A1	A0	C1	C0	D9.....D0 MSB.....LSB	S1 S0	
0	0	0	1	10-bit DAC data	0 0	Load input register A; DAC registers unchanged.
0	1	0	1	10-bit DAC data	0 0	Load input register B; DAC registers unchanged.
1	0	0	1	10-bit DAC data	0 0	Load input register C; DAC registers unchanged.
1	1	0	1	10-bit DAC data	0 0	Load input register D; DAC registers unchanged.
0	0	1	1	10-bit DAC data	0 0	Load input register A; all DAC registers updated.
0	1	1	1	10-bit DAC data	0 0	Load input register B; all DAC registers updated.
1	0	1	1	10-bit DAC data	0 0	Load input register C; all DAC registers updated.
1	1	1	1	10-bit DAC data	0 0	Load input register D; all DAC registers updated.
0	1	0	0	XXXXXXXXXX	X X	Update all DAC registers from their respective input registers (also exit shutdown mode).
1	0	0	0	10-bit DAC data	0 0	Load all DAC registers from shift register (also exit shutdown mode).
1	1	0	0	XXXXXXXXXX	X X	Enter shutdown mode (provided $\overline{PDL} = 1$ ).
0	0	1	0	XXXXXXXXXX	X X	UPO goes low (default).
0	1	1	0	XXXXXXXXXX	X X	UPO goes high.
0	0	0	0	XXXXXXXXXX	X X	No operation (NOP) to DAC registers
1	1	1	0	XXXXXXXXXX	X X	Mode 1, DOUT clocked out on SCLK's rising edge. All DAC registers updated.
1	0	1	0	XXXXXXXXXX	X X	Mode 0, DOUT clocked out on SCLK's falling edge. All DAC registers updated (default).

"X" = Don't care

Figure 5 shows the serial-interface timing requirements. The chip-select pin ( $\overline{CS}$ ) must be low to enable the DAC's serial interface. When  $\overline{CS}$  is high, the interface control circuitry is disabled.  $\overline{CS}$  must go low at least  $t_{CSS}$  before the rising serial clock (SCLK) edge to properly clock in the first bit. When  $\overline{CS}$  is low, data is clocked into the internal shift register through the serial-data input pin (DIN) on SCLK's rising edge. The maximum guaranteed clock frequency is 10MHz. Data is latched into the appropriate MAX5250 input/DAC registers on  $\overline{CS}$ 's rising edge.

The programming command Load-All-DACs-From-Shift-Register allows all input and DAC registers to be simultaneously loaded with the same digital code from the input shift register. The no operation (NOP) command leaves the register contents unaffected and is useful when the MAX5250 is configured in a daisy chain (see the *Daisy Chaining Devices* section). The command to

change the clock edge on which serial data is shifted out of DOUT also loads data from all input registers to their respective DAC registers.

### Serial-Data Output (DOUT)

The serial-data output, DOUT, is the internal shift register's output. The MAX5250 can be programmed so that data is clocked out of DOUT on SCLK's rising edge (Mode 1) or falling edge (Mode 0). In Mode 0, output data at DOUT lags input data at DIN by 16.5 clock cycles, maintaining compatibility with MICROWIRE, SPI/QSPI, and other serial interfaces. In Mode 1, output data lags input data by 16 clock cycles. On power-up, DOUT defaults to Mode 0 timing.

### User-Programmable Logic Output (UPO)

The user-programmable logic output, UPO, allows an external device to be controlled through the MAX5250 serial interface (Table 1).

# Low-Power, Quad, 10-Bit Voltage-Output DAC with Serial Interface

MAX5250

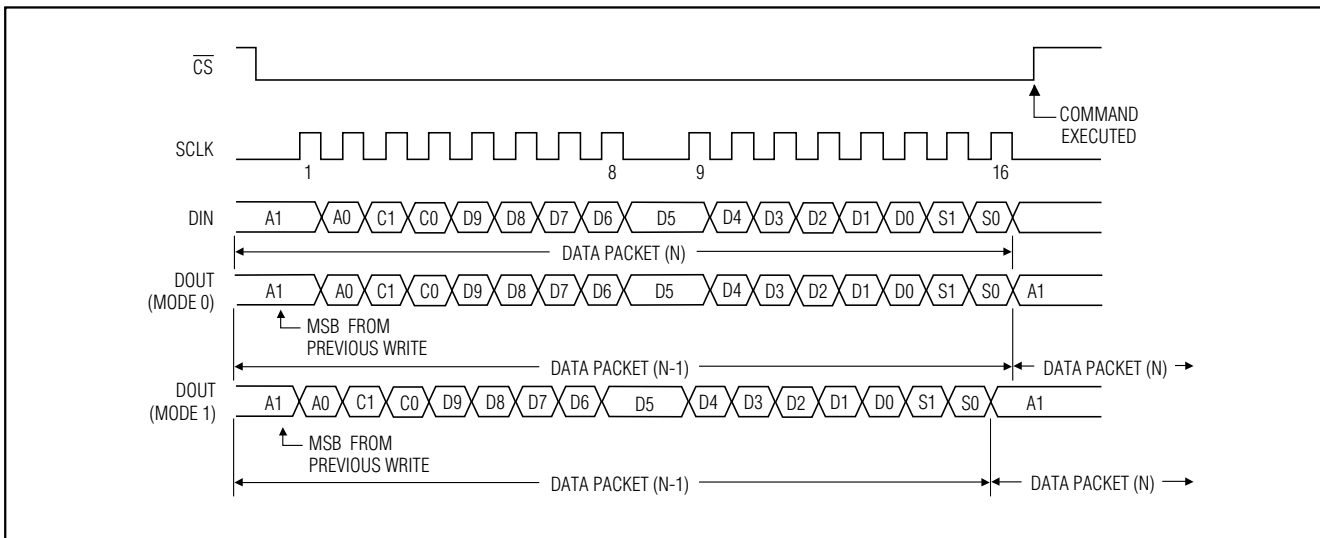

Figure 5. Serial-Interface Timing Diagram

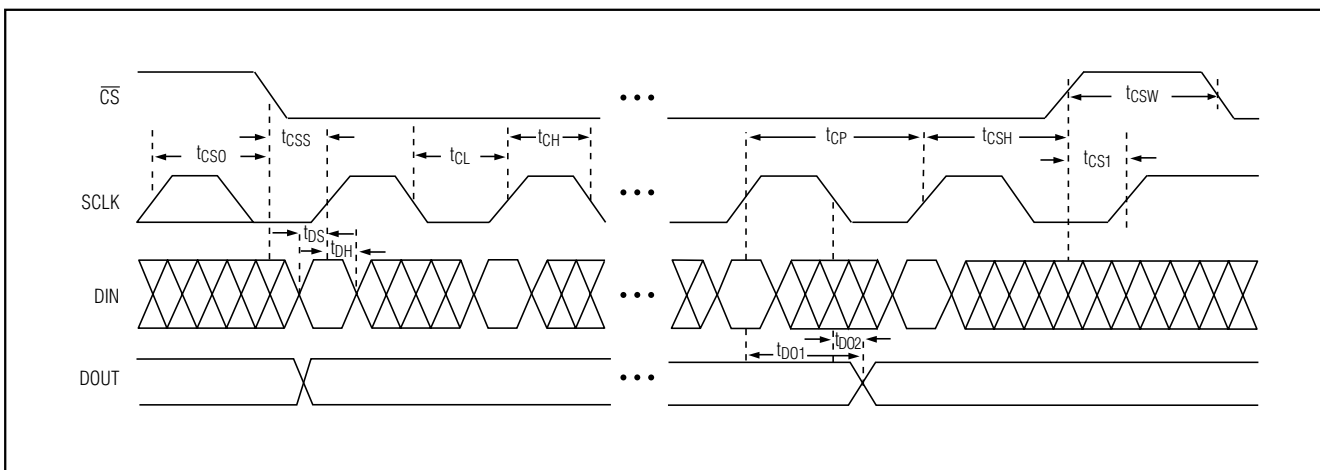

Figure 6. Detailed Serial-Interface Timing Diagram

## Power-Down (PDL)

The power-down lockout pin  $\overline{\text{PDL}}$  disables software shutdown when low. When in shutdown, transitioning  $\overline{\text{PDL}}$  from high to low wakes up the part with the output set to the state prior to shutdown.  $\overline{\text{PDL}}$  can also be used to wake up the device asynchronously.

## Daisy Chaining Devices

Any number of MAX5250s can be daisy chained by connecting the DOUT pin of one device to the DIN pin of the following device in the chain (Figure 7).

Since the MAX5250's DOUT pin has an internal active pull-up, the DOUT sink/source capability determines the time required to discharge/charge a capacitive load. Refer to the serial-data-out  $\text{VOH}$  and  $\text{VOL}$  specifications in the *Electrical Characteristics*.

Figure 8 shows an alternate method of connecting several MAX5250s. In this configuration, the data bus is common to all devices; data is not shifted through a daisy chain. More I/O lines are required in this configuration because a dedicated chip-select input (CS) is required for each IC.

# Low-Power, Quad, 10-Bit Voltage-Output DAC with Serial Interface

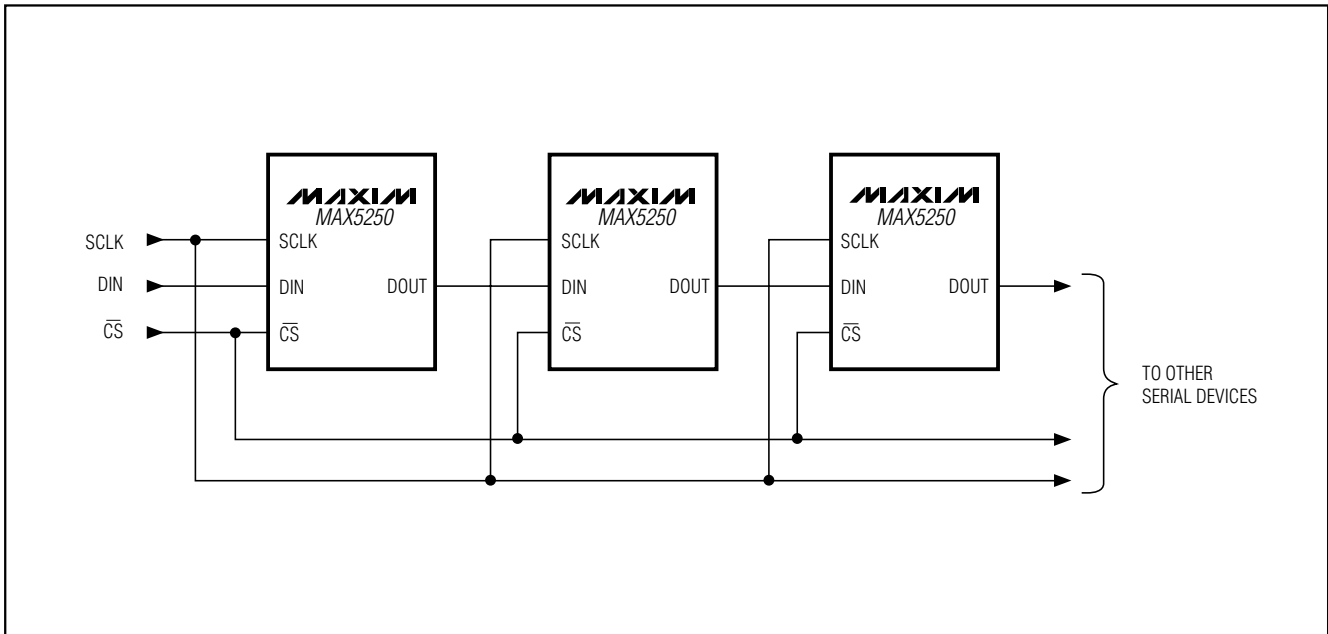

Figure 7. Daisy-Chaining MAX5250s

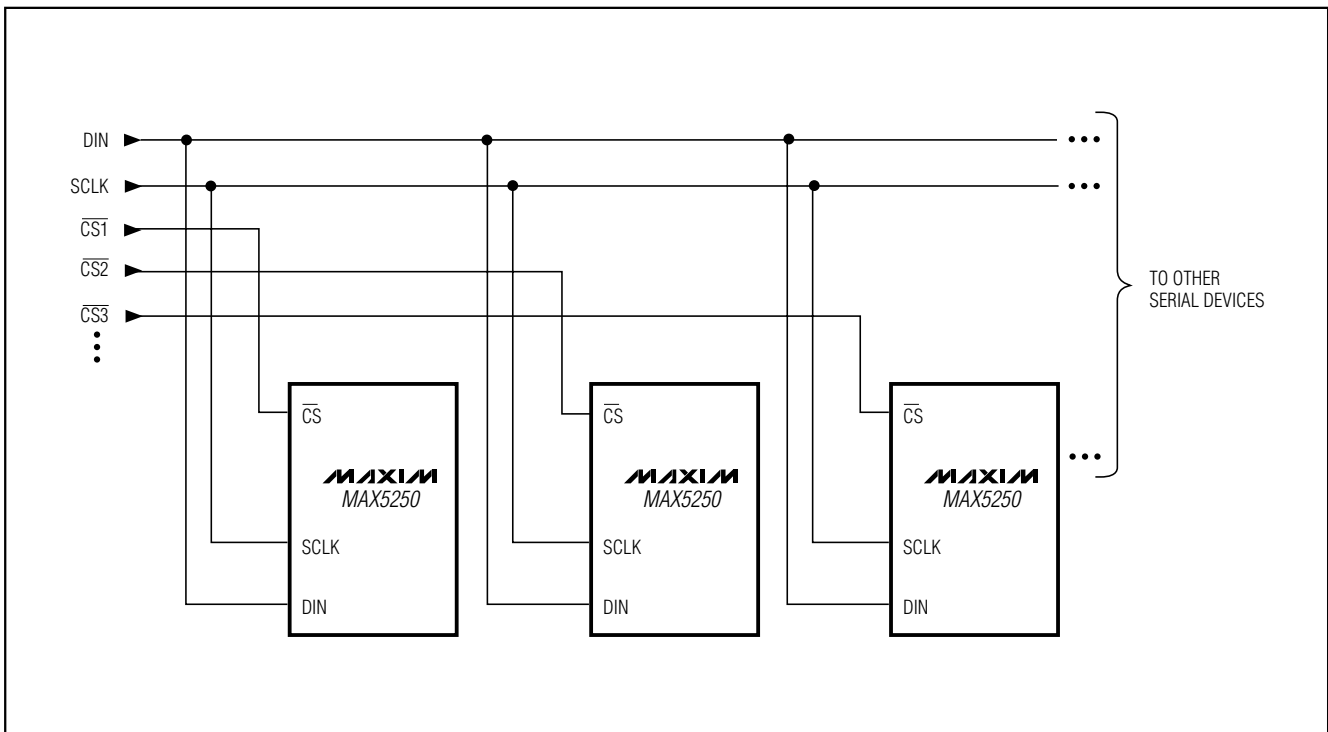

Figure 8. Multiple MAX5250s Sharing a Common DIN Line

# Low-Power, Quad, 10-Bit Voltage-Output DAC with Serial Interface

## Applications Information

### Unipolar Output

For a unipolar output, the output voltages and the reference inputs have the same polarity. Figure 9 shows the MAX5250 unipolar output circuit, which is also the typical operating circuit. Table 2 lists the unipolar output codes.

For rail-to-rail outputs, see Figure 10. This circuit shows the MAX5250 with the output amplifiers configured with a closed-loop gain of +2 to provide 0V to 5V full-scale range when a 2.5V reference is used.

**Table 2. Unipolar Code Table**

DAC CONTENTS			ANALOG OUTPUT
MSB	LSB		
1111	1111	11(00)	$+V_{REF} \left( \frac{1023}{1024} \right)$
1000	0000	01(00)	$+V_{REF} \left( \frac{513}{1024} \right)$
1000	0000	00(00)	$+V_{REF} \left( \frac{512}{1024} \right) = \frac{+V_{REF}}{2}$
0111	1111	11(00)	$+V_{REF} \left( \frac{511}{1024} \right)$
0000	0000	01(00)	$+V_{REF} \left( \frac{1}{1024} \right)$
0000	0000	00(00)	0V

**Table 3. Bipolar Code Table**

DAC CONTENTS			ANALOG OUTPUT
MSB	LSB		
1111	1111	11(00)	$+V_{REF} \left( \frac{511}{512} \right)$
1000	0000	01(00)	$+V_{REF} \left( \frac{1}{512} \right)$
1000	0000	00(00)	0V
0111	1111	11(00)	$-V_{REF} \left( \frac{1}{512} \right)$
0000	0000	01(00)	$-V_{REF} \left( \frac{511}{512} \right)$
0000	0000	00(00)	$-V_{REF} \left( \frac{512}{512} \right) = -V_{REF}$

( ) Sub-bits

### Bipolar Output

The MAX5250 outputs can be configured for bipolar operation using Figure 11's circuit:

$$V_{OUT} = V_{REF} [(2NB / 1024) - 1]$$

where NB is the numeric value of the DAC's binary input code. Table 3 shows digital codes (offset binary) and corresponding output voltages for Figure 11's circuit.

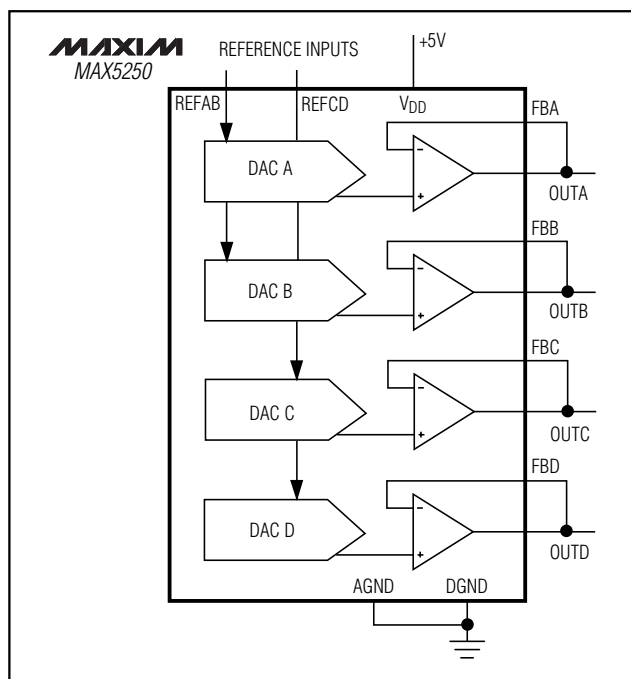

Figure 9. Unipolar Output Circuit

# Low-Power, Quad, 10-Bit Voltage-Output DAC with Serial Interface

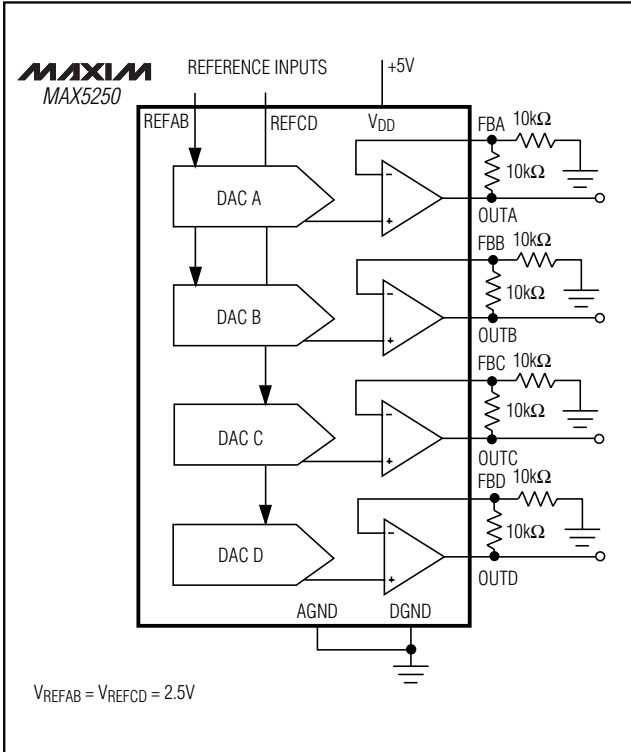

Figure 10. Unipolar Rail-to-Rail Output Circuit

### Using an AC Reference

In applications where the reference has AC signal components, the MAX5250 has multiplying capability within the reference input range specifications. Figure 12 shows a technique for applying a sine-wave signal to the reference input where the AC signal is offset before being applied to REFAB/REFCO. The reference voltage must never be more negative than DGND.

The MAX5250's total harmonic distortion plus noise (THD + N) is typically less than -72dB (full-scale code), given a 1V<sub>P-P</sub> signal swing and input frequencies up to 25kHz. The typical -3dB frequency is 650kHz, as shown in the *Typical Operating Characteristics* graphs.

### Digitally Programmable Current Source

The circuit of Figure 13 places an NPN transistor (2N3904 or similar) within the op-amp feedback loop to implement a digitally programmable, unidirectional current source. This circuit can be used to drive 4–20mA current loops, which are commonly used in industrial-control applications. The output current is calculated with the following equation:

$$I_{OUT} = (V_{REF} / R) \times (NB / 1024)$$

where NB is the numeric value of the DAC's binary input code and R is the sense resistor shown in Figure 13.

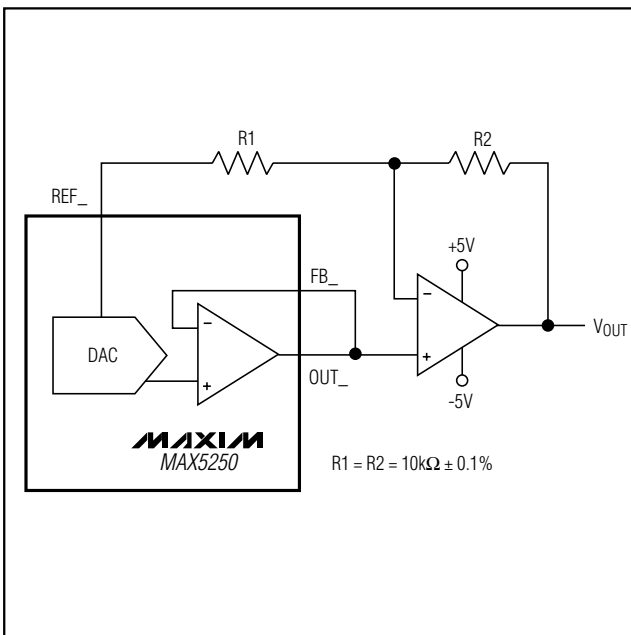

Figure 11. Bipolar Output Circuit

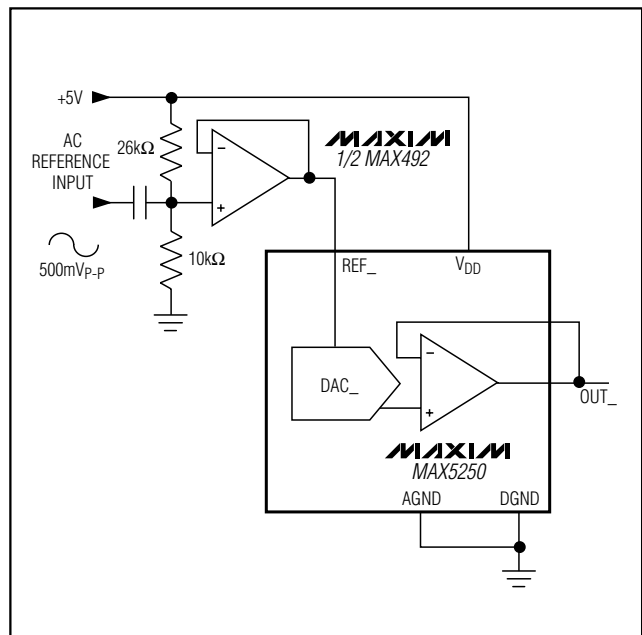

Figure 12. AC Reference Input Circuit

# Low-Power, Quad, 10-Bit Voltage-Output DAC with Serial Interface

**MAX5250**

## Pin Configuration

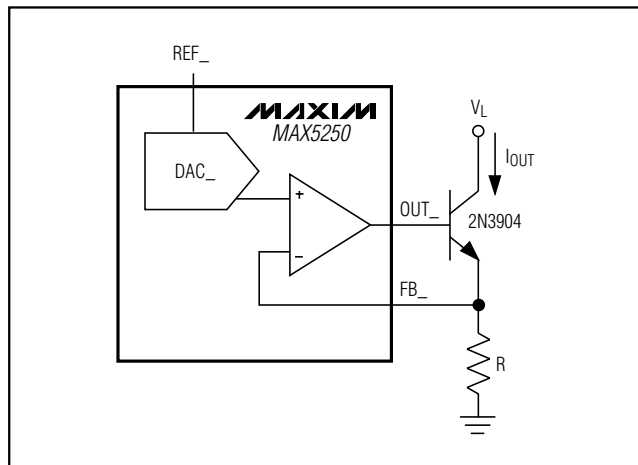

Figure 13. Digitally Programmable Current Source

### Power-Supply Considerations

On power-up, all input and DAC registers are cleared (set to zero code) and DOUT is in Mode 0 (serial data is shifted out of DOUT on the clock's falling edge).

For rated MAX5250 performance, limit REFAB/REFCD to less than 1.4V below V<sub>DD</sub>. Bypass V<sub>DD</sub> with a 4.7μF capacitor in parallel with a 0.1μF capacitor to AGND. Use short lead lengths and place the bypass capacitors as close to the supply pins as possible.

### Grounding and Layout Considerations

Digital or AC transient signals between AGND and DGND can create noise at the analog outputs. Tie AGND and DGND together at the DAC, then tie this point to the highest-quality ground available.

Good printed circuit board ground layout minimizes crosstalk between DAC outputs, reference inputs, and digital inputs. Reduce crosstalk by keeping analog lines away from digital lines. Wire-wrapped boards are not recommended.



# Low-Power, Quad, 10-Bit Voltage-Output DAC with Serial Interface

## Ordering Information (continued)

PART	TEMP RANGE	PIN-PACKAGE	INL (LSB)
MAX5250AEPP	-40°C to +85°C	20 Plastic DIP	±1/2
MAX5250BEPP	-40°C to +85°C	20 Plastic DIP	±1
MAX5250AEAP	-40°C to +85°C	20 SSOP	±1/2
MAX5250BEAP	-40°C to +85°C	20 SSOP	±1
MAX5250BMJP	-55°C to +125°C	20 CERDIP*	±1

\*Contact factory for availability and processing to MIL-STD-883.

## Chip Information

TRANSISTOR COUNT: 4337

## Package Information

(The package drawing(s) in this data sheet may not reflect the most current specifications. For the latest package outline information, go to [www.maxim-ic.com/packages](http://www.maxim-ic.com/packages).)

DIM	INCHES		MILLIMETERS	
	MIN	MAX	MIN	MAX
A	0.068	0.078	1.73	1.99
A1	0.002	0.008	0.05	0.21
B	0.010	0.015	0.25	0.38
C	0.004	0.008	0.09	0.20
D	SEE VARIATIONS			
E	0.205	0.212	5.20	5.38
e	0.0256 BSC		0.65 BSC	
H	0.301	0.311	7.65	7.90
L	0.025	0.037	0.63	0.95
α	0°	8°	0°	8°

DIM	INCHES		MILLIMETERS		N
	MIN	MAX	MIN	MAX	
D	0.239	0.249	6.07	6.33	14L
D	0.239	0.249	6.07	6.33	16L
D	0.278	0.289	7.07	7.33	20L
D	0.317	0.328	8.07	8.33	24L
D	0.397	0.407	10.07	10.33	28L

NOTES:

- D&E DO NOT INCLUDE MOLD FLASH.
- MOLD FLASH OR PROTRUSIONS NOT TO EXCEED .15 MM (.006").
- CONTROLLING DIMENSION: MILLIMETERS.
- MEETS JEDEC MO150.
- LEADS TO BE COPLANAR WITHIN 0.10 MM.

**DALLAS SEMICONDUCTOR** **MAXIM**

PROPRIETARY INFORMATION

TITLE: PACKAGE OUTLINE, SSOP, 5.3 MM

APPROVAL: \_\_\_\_\_ DOCUMENT CONTROL NO: 21-0056 REV: C 1/1

Maxim cannot assume responsibility for use of any circuitry other than circuitry entirely embodied in a Maxim product. No circuit patent licenses are implied. Maxim reserves the right to change the circuitry and specifications without notice at any time.

16 **Maxim Integrated Products, 120 San Gabriel Drive, Sunnyvale, CA 94086 (408) 737-7600**





Компания «ЭлектроПласт» предлагает заключение долгосрочных отношений при поставках импортных электронных компонентов на взаимовыгодных условиях!

Наши преимущества:

- Оперативные поставки широкого спектра электронных компонентов отечественного и импортного производства напрямую от производителей и с крупнейших мировых складов;
- Поставка более 17-ти миллионов наименований электронных компонентов;
- Поставка сложных, дефицитных, либо снятых с производства позиций;
- Оперативные сроки поставки под заказ (от 5 рабочих дней);
- Экспресс доставка в любую точку России;
- Техническая поддержка проекта, помощь в подборе аналогов, поставка прототипов;
- Система менеджмента качества сертифицирована по Международному стандарту ISO 9001;
- Лицензия ФСБ на осуществление работ с использованием сведений, составляющих государственную тайну;
- Поставка специализированных компонентов (Xilinx, Altera, Analog Devices, Intersil, Interpoint, Microsemi, Aeroflex, Peregrine, Syfer, Eurofarad, Texas Instrument, Miteq, Cobham, E2V, MA-COM, Hittite, Mini-Circuits, General Dynamics и др.);

Помимо этого, одним из направлений компании «ЭлектроПласт» является направление «Источники питания». Мы предлагаем Вам помощь Конструкторского отдела:

- Подбор оптимального решения, техническое обоснование при выборе компонента;
- Подбор аналогов;
- Консультации по применению компонента;
- Поставка образцов и прототипов;
- Техническая поддержка проекта;
- Защита от снятия компонента с производства.



#### Как с нами связаться

**Телефон:** 8 (812) 309 58 32 (многоканальный)

**Факс:** 8 (812) 320-02-42

**Электронная почта:** [org@eplast1.ru](mailto:org@eplast1.ru)

**Адрес:** 198099, г. Санкт-Петербург, ул. Калинина, дом 2, корпус 4, литера А.