

Product Description

Qorvo's QPA2576N is a wideband power amplifier fabricated on Qorvo's proven 0.25 μm GaN on SiC production technology. Operating from 2.5 to 6 GHz, the QPA2576N achieves 40 W of saturated output power, greater than 36% power-added efficiency and 29 dB small signal gain.

For ideal thermal management and handling, the QPA2576N is offered in a CuW –based flanged packaged and can operate in both CW and pulsed modes.

Both RF ports are fully matched to 50 Ω , the QPA2576N is ideally suited to support a variety of commercial and defense related applications.

Lead-free and RoHS compliant

Evaluation Boards are available up on request.

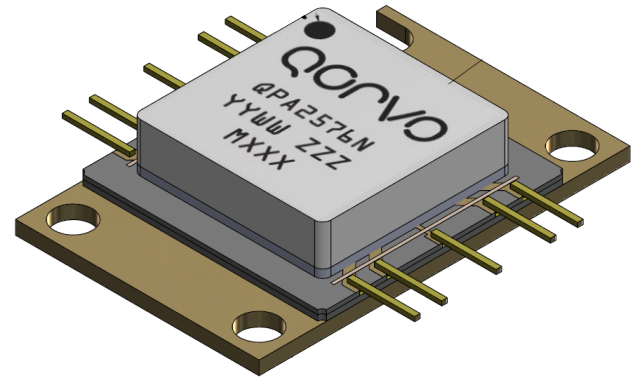

Product Features

- Frequency Range: 2.5 to 6 GHz
- P_{SAT} : 46.5 dBm ($P_{IN} = 26$ dBm, CW)
- PAE: 36% ($P_{IN} = 26$ dBm, CW)
- Small Signal Gain: 29 dB
- Bias: $V_D = 30$ V, $I_{DQ} = 1.55$ A, $V_G = -2.5$ V Typical
- Dimensions: 11.4 x 17.3 x 3.0 mm

Performance is typical across frequency. Please reference electrical specification table and data plots for more details.

Functional Block Diagram

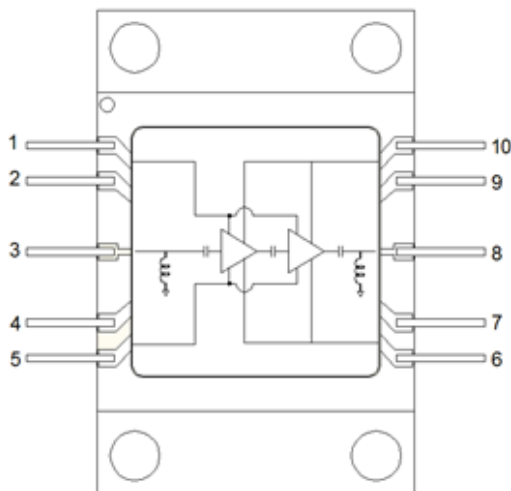

Applications

- Communications
- Electronic Warfare
- Test Instrumentation
- EMC Amplifier

Ordering Information

Part	Description
QPA2576N	2.5 to 6.0 GHz 40 W GaN PA



Absolute Maximum Ratings

Parameter	Value / Range
Drain Voltage (V_D)	40 V
Gate Voltage (V_G)	-5 to 0 V
Drain Current (I_D)	5000 mA
Gate Current (I_G)	-18 to +35 mA
Dissipated Power (P_{DISS}) ¹	93 W
Input Power (50 Ω , 25 °C)	28 dBm
Mounting Temperature (30 seconds)	260 °C
Storage Temperature	-40 to 150 °C

Operation of this device outside the parameter ranges given above may cause permanent damage. These are stress ratings only, and functional operation of the device at these conditions is not implied.

Recommended Operating Conditions

Parameter	Value
Drain Voltage	30 V
Drain Current (quiescent, I_{DQ})	1550 mA
Drain Current (under drive, I_D)	4300 mA
Gate Voltage	-2.5 V
Operating Temperature Range	-40 to 85 °C

Electrical specifications are measured at specified test conditions. Specifications are not guaranteed over all recommended operating conditions.

Electrical Specifications

Test conditions, unless otherwise noted: 25 °C, $V_D = 30$ V, $I_{DQ} = 1550$ mA, $V_G = -2.5$ V typical, CW

Parameter	Min	Typ	Max	Units
Operational Frequency Range	2.5		6.0	GHz
Output Power ($P_{IN} = 26$ dBm)		46.5		dBm
Power Added Efficiency ($P_{IN} = 26$ dBm, midband)		36		%
Small Signal Gain		29		dB
Input Return Loss		11		dB
Output Return Loss		13		dB
Small Signal Gain Temperature Coefficient		-0.020		dBm/°C
Output Power Temperature Coefficient		-0.020		dBm/°C

Performance Plots – Large Signal (CW)

Test conditions unless otherwise noted: $V_D = 30\text{ V}$, $I_{DQ} = 1550\text{ mA}$, $V_G = -2.5\text{ V}$ typical, CW

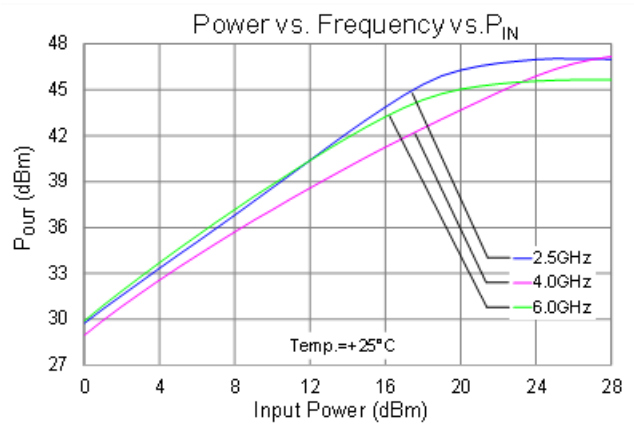
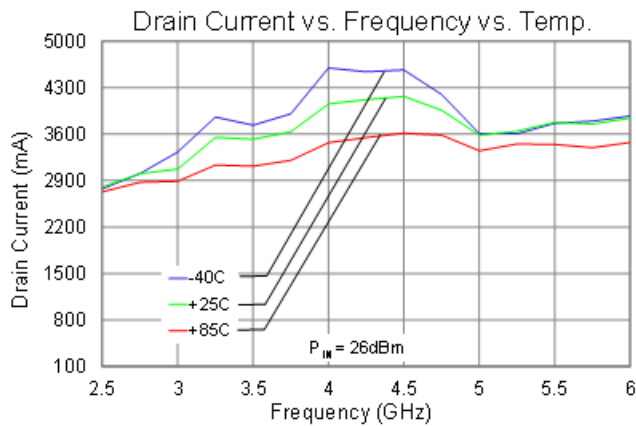
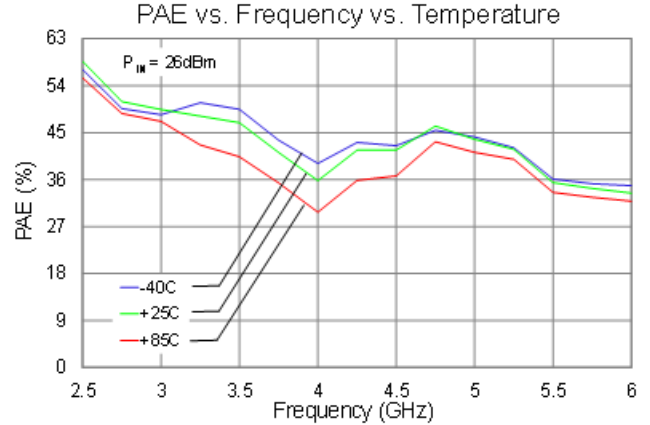
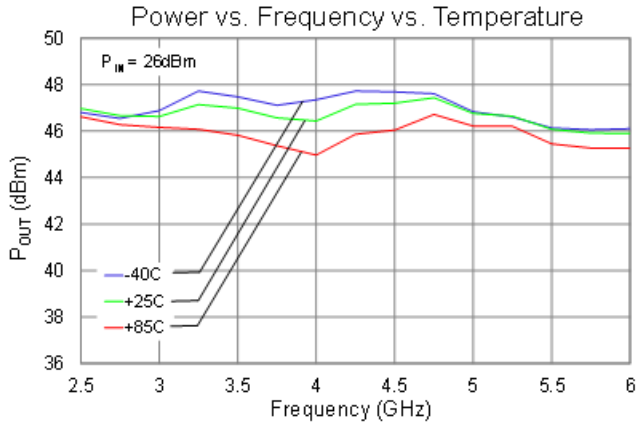

Performance Plots – Large Signal (CW)

Test conditions unless otherwise noted: $V_D = 30\text{ V}$, $I_{DQ} = 1550\text{ mA}$, $V_G = -2.5\text{ V}$ typical, CW

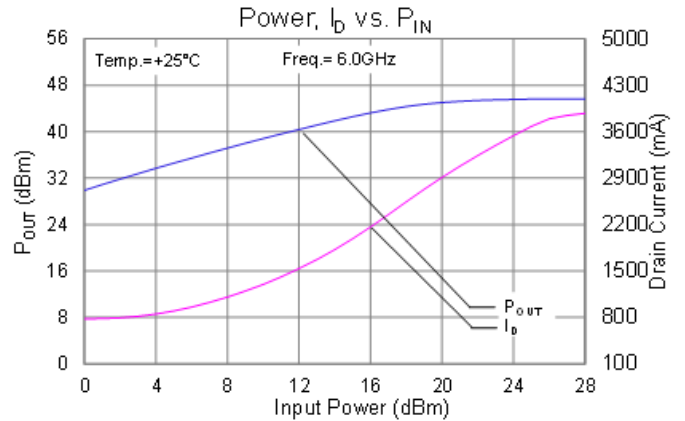
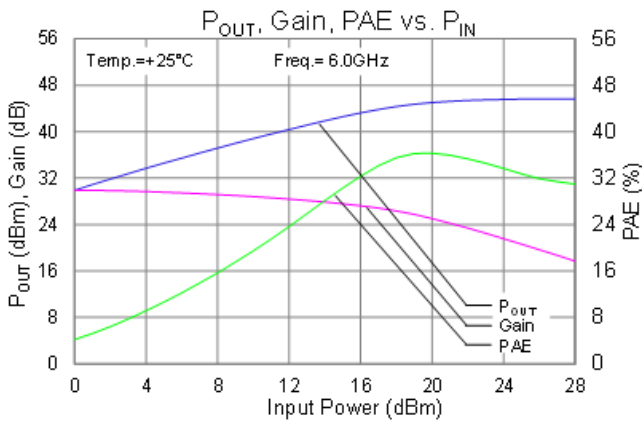
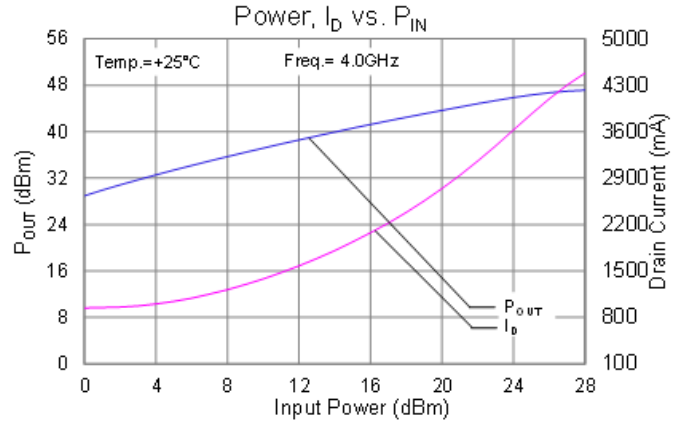
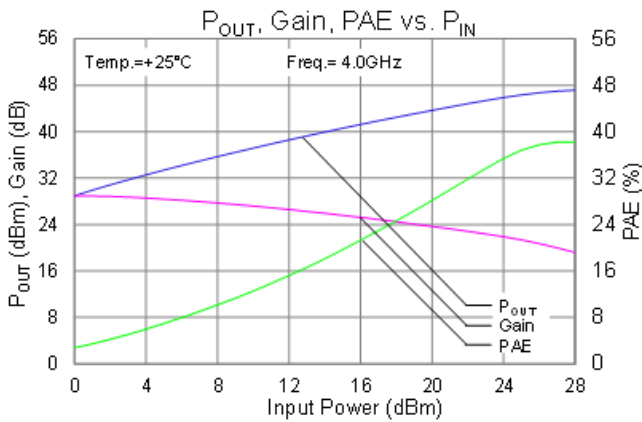
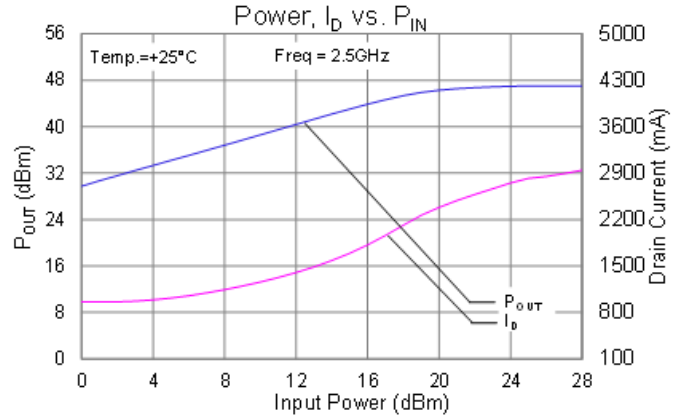
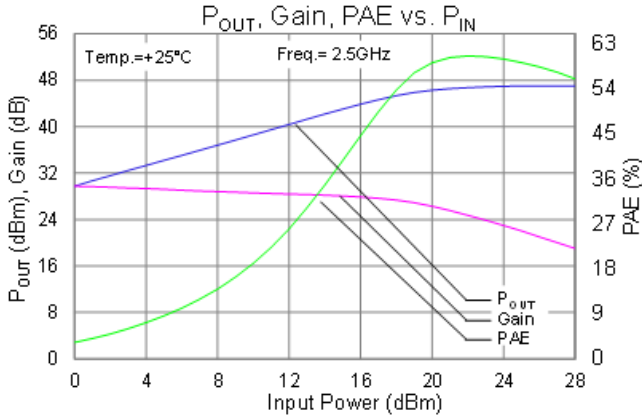

Performance Plots – Small Signal

Test conditions unless otherwise noted: $V_D = 30\text{ V}$, $I_{DQ} = 1550\text{ mA}$, $V_G = -2.5\text{ V}$ typical, CW

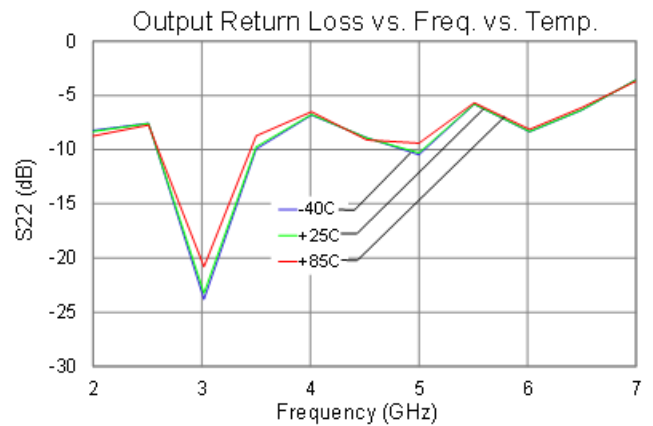
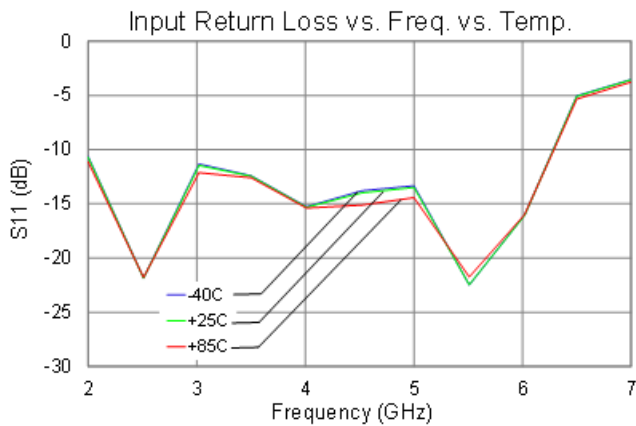
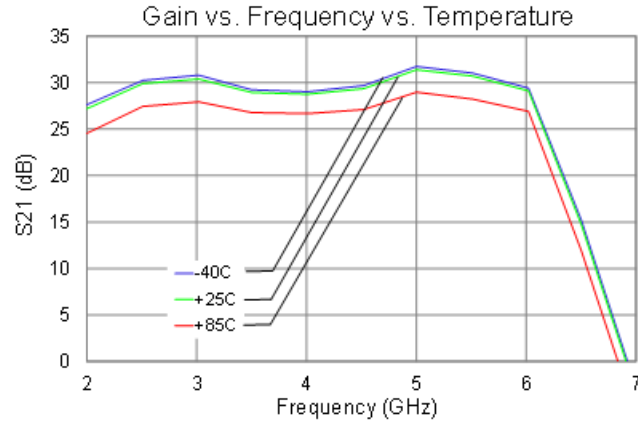

Thermal and Reliability Information

Parameter	Test Conditions	Value	Units
Thermal Resistance (θ_{JC}) ⁽¹⁾	$T_{base} = 85^{\circ}\text{C}$	1.32	$^{\circ}\text{C/W}$
Channel Temperature (T_{CH}) (Quiescent)	$V_D = 30\text{ V}$, $I_{DQ} = 1500\text{ mA}$, $I_{D_DRIVE} = 3600\text{ mA}$, $P_{OUT} = 46\text{ dBm}$, $P_{DISS} = 68\text{ W}$	175	$^{\circ}\text{C}$

Notes:

1. Thermal resistance is measured to the backside of the package.
2. Refer to the following document: [GaN Device Channel Temperature, Thermal Resistance, and Reliability Estimates](#)

Applications Circuit

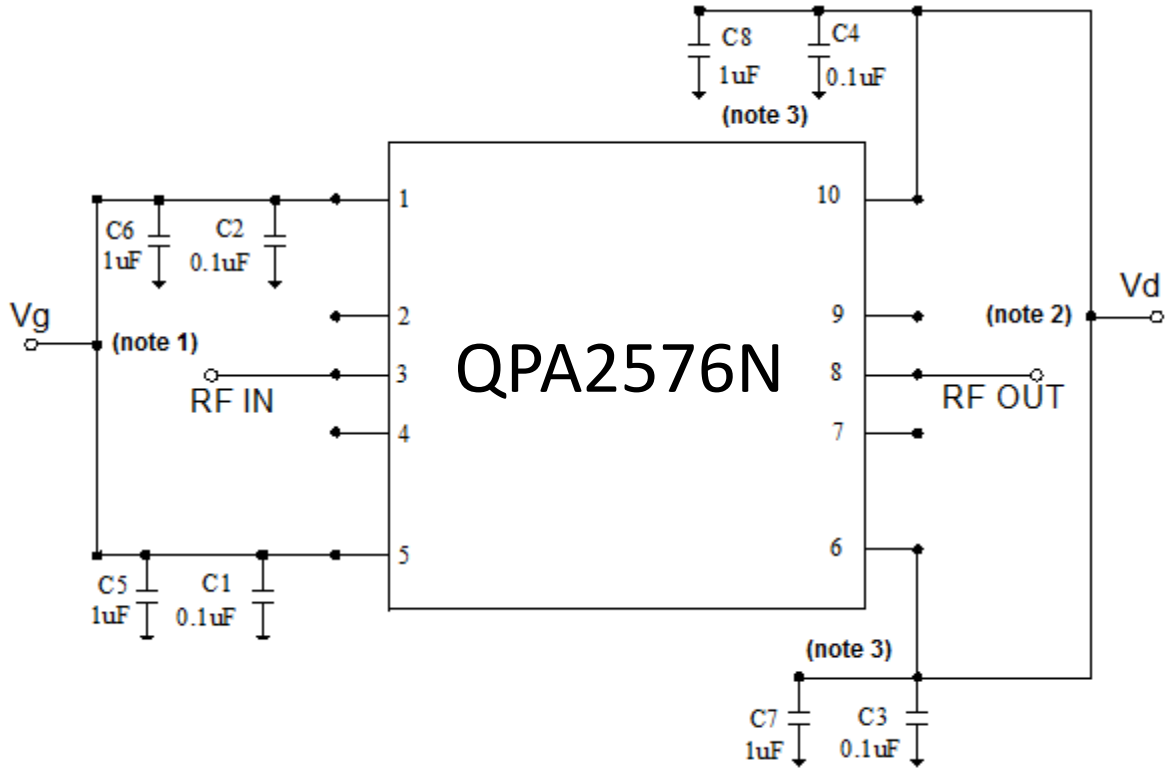

Notes:

1. V_G must be biased from both sides (pins 1 and 5).
2. V_D must be biased from both sides (pins 6 and 10).
3. Remove large capacitors for pulsed drain operation.

Bias Up Procedure

1. Set I_D limit to 4500 mA, I_G limit to 20 mA
2. Set V_G to -5.0 V
3. Set V_D +30 V
4. Adjust V_G more positive until $I_{DQ} = 1550$ mA ($V_G \sim -2.5$ V Typical)
5. Apply RF signal

Bias Down Procedure

1. Turn off RF signal
2. Reduce V_G to -5.0 V. Ensure $I_{DQ} \sim 0$ mA
3. Set V_D to 0 V
4. Set V_G to 0 V

Pin Description

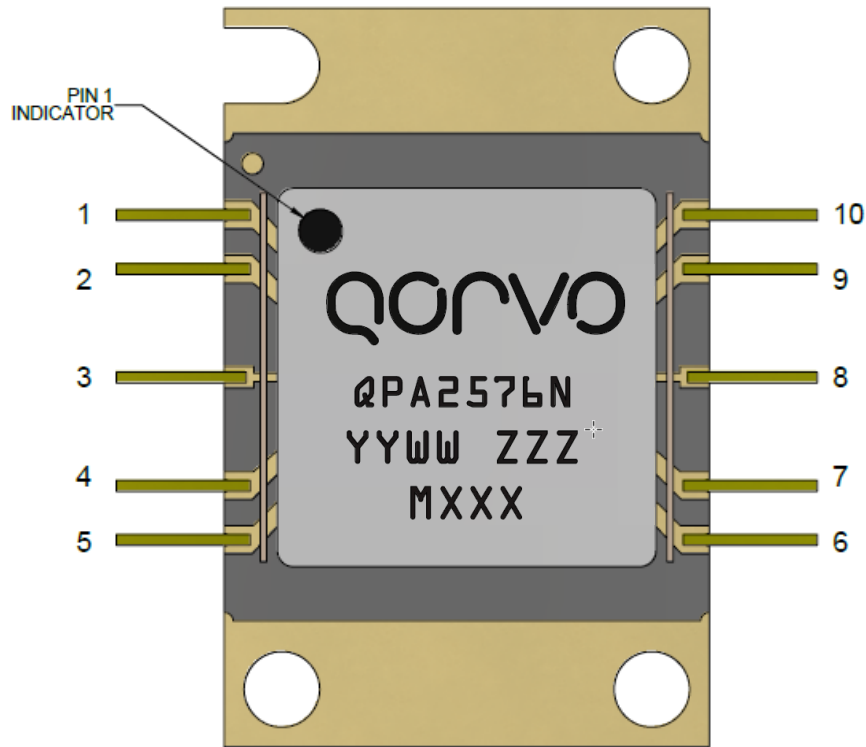

Pin Number	Symbol	Description
1, 5	V_G	Gate voltage ⁽¹⁾
2, 4, 7, 9	N/C	No internal connection; may be grounded or left open on PCB
3	RF IN	Input; matched to 50 Ω ; DC blocked and shorted to ground
6, 10	V_D	Drain voltage ⁽²⁾
8	RF OUT	Output; matched to 50 Ω ; DC blocked and shorted to ground
	(Package Base)	RF and DC ground

Notes:

1. Bias network is required; must be biased from both sides (Pins 1 and 5); see Application Circuit on page 7 as an example.
2. Bias network is required; must be biased from both sides (Pins 6 and 10); see Application Circuit on page 7 as an example

Evaluation Board and Mounting Detail

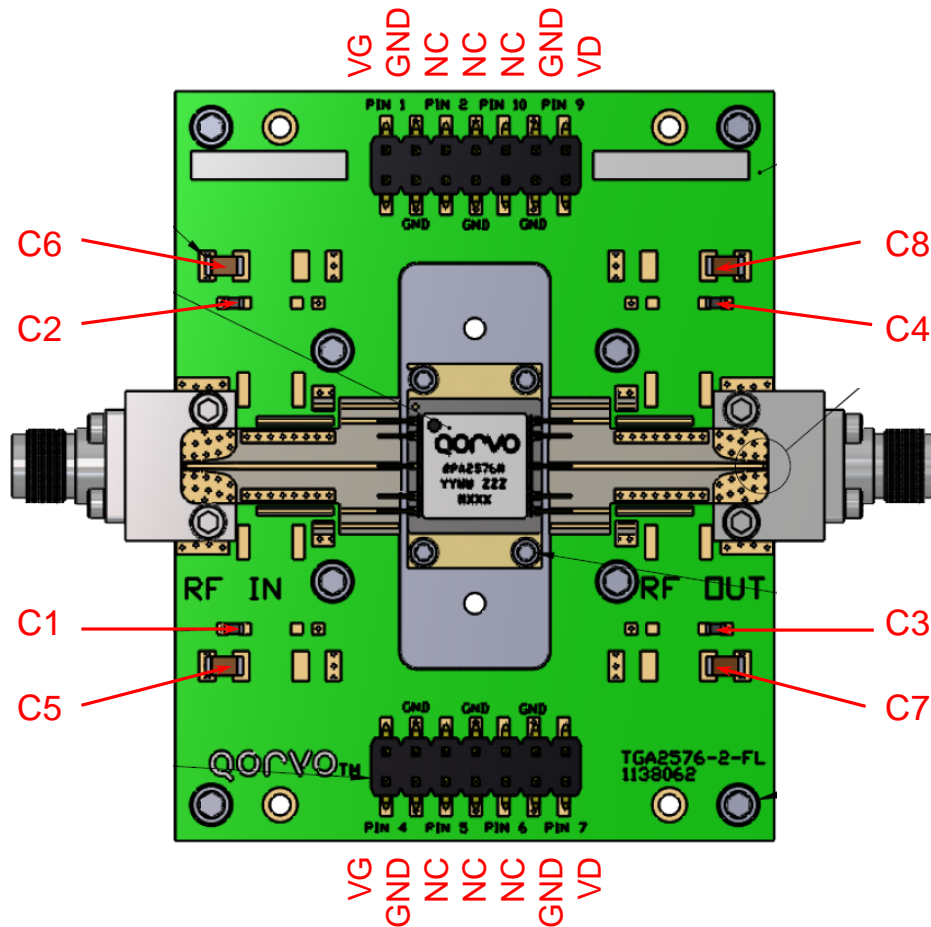

RF Layer is 0.008" thick Rogers Corp. RO4003C ($\epsilon_r = 3.35$). Metal layers are 0.5 oz. copper. Note: Can remove C3, C4, C7, C8 for pulsed operation.

Bill of Materials

Reference Des.	Value	Description	Manuf.	Part Number
C1 – C4	0.1 μ F	CAP, 0.1 uF, 10%, 50 V, X7R, 0603	Various	
C5 – C8	1 μ F	CAP, 1 uF, 5% 50 V, X7R, 1206	Various	
J1, J2	2.92 mm	CONNECTOR, FEMALE, ENDLAUNCH	Southwest Microwave	1092-01A-5

Mechanical Information

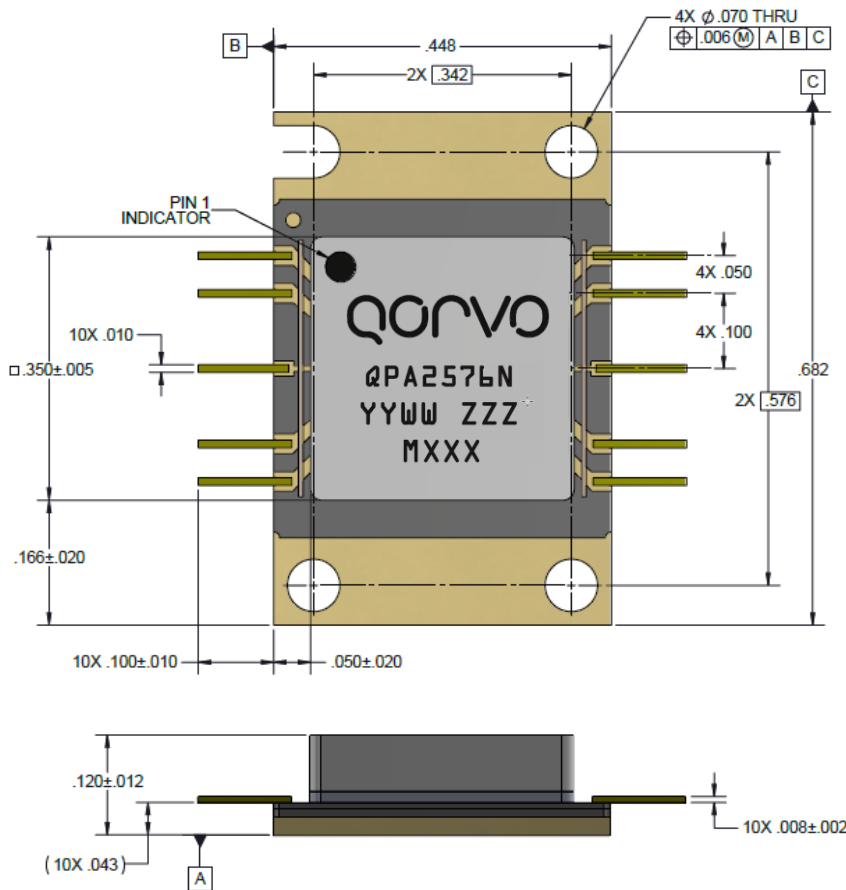

NOTES:

1. PACKAGE; CERAMIC ON METAL FLANGE
2. THE PART IS EPOXY SEALED
3. ALL METALIZED FEATURES ARE GOLD PLATED
4. UNLESS SPECIFIED OTHERWISE, DIMENSIONS ARE IN INCHES
5. UNLESS SPECIFIED OTHERWISE, TOLERANCES ARE ±0.005

MARKING:

1. PART NUMBER: QPA2576N
2. YEAR/WEEK/LOT CODE: YYWW ZZZ
3. BATCH ID: MXXX

Assembly Notes

1. 0-80 screws are recommended for mounting the QPA2576N to the heat sink
2. To improve the thermal and RF performance, attach a heat sink to the bottom of the board and apply thermal compound or 4 mils indium shim between the heat sink and the package
3. Apply solder to each pin of the QPA2576N
4. The use of no-clean solder to avoid washing after soldering is recommended.

Recommended Soldering Temperature Profile

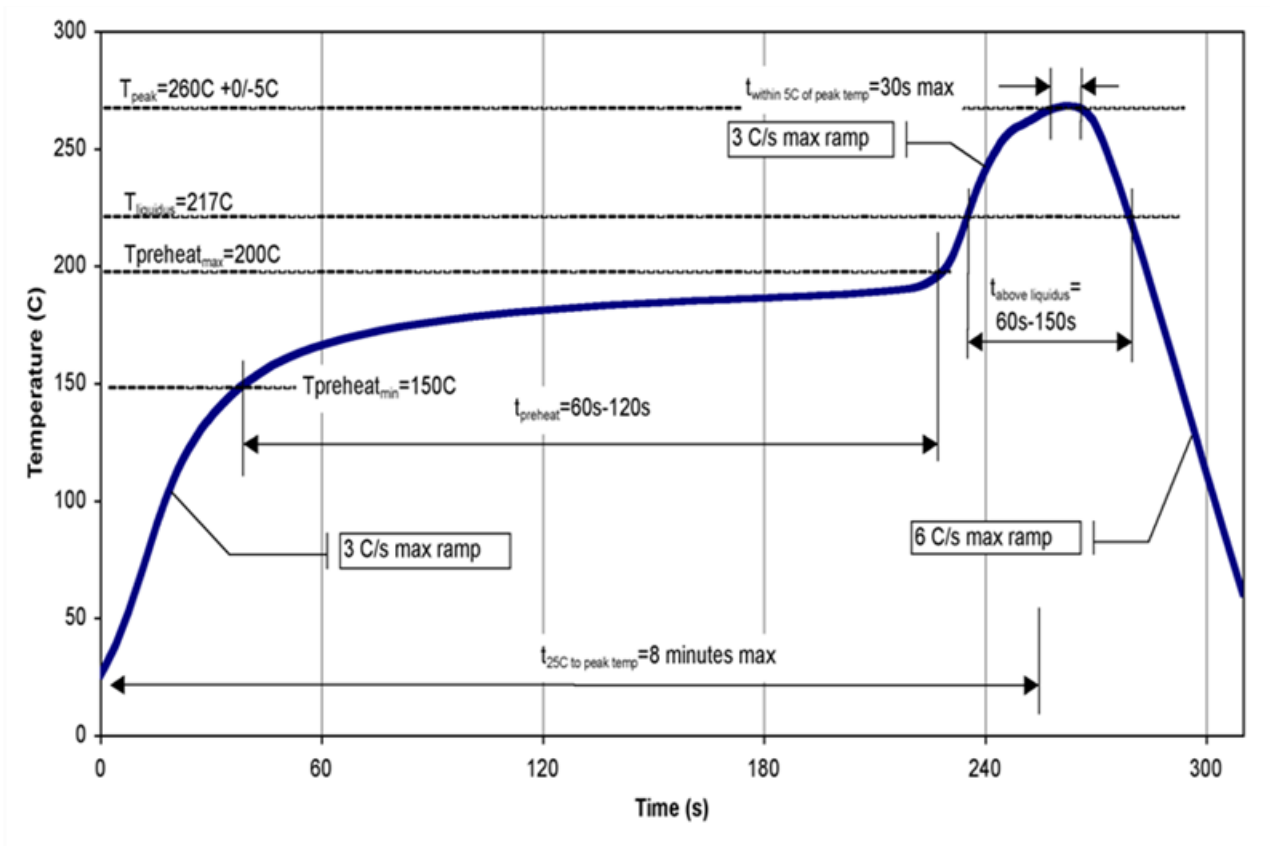

Handling Precautions

Parameter	Rating	Standard
ESD – Human Body Model (HBM)	Class 1B	ANSI/ESD/JEDEC JS-001
MSL – Moisture Sensitivity Level	Level 5A	IPC/JEDEC J-STD-020



Caution!
ESD-Sensitive Device

Solderability

Compatible with the latest version of J-STD-020 Lead free solder, 260 °C. The use of no-clean solder to avoid washing after soldering is recommended.

RoHS Compliance

This product is compliant with the 2011/65/EU RoHS directive (Restrictions on the Use of Certain Hazardous Substances in Electrical and Electronic Equipment), as amended by Directive 2015/863/EU. This product also has the following attributes:

- Lead Free
- Halogen Free (Chlorine, Bromine)
- Antimony Free
- TBBP-A (C₁₅H₁₂Br₄O₂) Free
- PFOS Free
- SVHC Free
- Qorvo Green

Contact Information

For the latest specifications, additional product information, worldwide sales and distribution locations:

Tel: **1-844-890-8163**

Web: www.qorvo.com

Email: customer.support@qorvo.com

Important Notice

The information contained herein is believed to be reliable. Qorvo makes no warranties regarding the information contained herein. Qorvo assumes no responsibility or liability whatsoever for any of the information contained herein. Qorvo assumes no responsibility or liability whatsoever for the use of the information contained herein. The information contained herein is provided "AS IS, WHERE IS" and with all faults, and the entire risk associated with such information is entirely with the user. All information contained herein is subject to change without notice. Customers should obtain and verify the latest relevant information before placing orders for Qorvo products. The information contained herein or any use of such information does not grant, explicitly or implicitly, to any party any patent rights, licenses, or any other intellectual property rights, whether with regard to such information itself or anything described by such information.

Qorvo products are not warranted or authorized for use as critical components in medical, life-saving, or life-sustaining applications, or other applications where a failure would reasonably be expected to cause severe personal injury or death.

Copyright 2016 © Qorvo, Inc. | Qorvo is a registered trademark of Qorvo, Inc.



Компания «ЭлектроПласт» предлагает заключение долгосрочных отношений при поставках импортных электронных компонентов на взаимовыгодных условиях!

Наши преимущества:

- Оперативные поставки широкого спектра электронных компонентов отечественного и импортного производства напрямую от производителей и с крупнейших мировых складов;
- Поставка более 17-ти миллионов наименований электронных компонентов;
- Поставка сложных, дефицитных, либо снятых с производства позиций;
- Оперативные сроки поставки под заказ (от 5 рабочих дней);
- Экспресс доставка в любую точку России;
- Техническая поддержка проекта, помощь в подборе аналогов, поставка прототипов;
- Система менеджмента качества сертифицирована по Международному стандарту ISO 9001;
- Лицензия ФСБ на осуществление работ с использованием сведений, составляющих государственную тайну;
- Поставка специализированных компонентов (Xilinx, Altera, Analog Devices, Intersil, Interpoint, Microsemi, Aeroflex, Peregrine, Syfer, Eurofarad, Texas Instrument, Miteq, Cobham, E2V, MA-COM, Hittite, Mini-Circuits, General Dynamics и др.);

Помимо этого, одним из направлений компании «ЭлектроПласт» является направление «Источники питания». Мы предлагаем Вам помощь Конструкторского отдела:

- Подбор оптимального решения, техническое обоснование при выборе компонента;
- Подбор аналогов;
- Консультации по применению компонента;
- Поставка образцов и прототипов;
- Техническая поддержка проекта;
- Защита от снятия компонента с производства.



Как с нами связаться

Телефон: 8 (812) 309 58 32 (многоканальный)

Факс: 8 (812) 320-02-42

Электронная почта: org@eplast1.ru

Адрес: 198099, г. Санкт-Петербург, ул. Калинина, дом 2, корпус 4, литера А.