

High Luminous Efficacy
Amber LED Emitter

LZ1-00A100



Key Features

- High Luminous Efficacy Amber LED
- Ultra-small foot print – 4.4mm x 4.4mm
- Surface mount ceramic package with integrated glass lens
- Very high Luminous Flux density
- New industry standard for Lumen Maintenance
- Autoclave compliant (JEDEC JESD22-A102-C)
- JEDEC Level 1 for Moisture Sensitivity Level
- Lead (Pb) free and RoHS compliant
- Reflow solderable (up to 6 cycles)
- Emitter available on Standard or Miniature MCPCB (optional)

Typical Applications

- Emergency vehicle lighting
- Strobe and warning lights
- Marine and buoy lighting
- Aviation and obstruction lighting
- Roadway beacons and traffic signaling
- Architectural lighting
- Stage and studio lighting
- Landscape lighting
- Automotive signal and marker lights

Description

The LZ1-00A100 Amber LED emitter provides 5W power in an extremely small package. With a 4.4mm x 4.4mm ultra-small footprint, this package provides exceptional luminous flux density. The patent-pending design has unparalleled thermal and optical performance. The high quality materials used in the package are chosen to optimize light output and minimize stresses which results in monumental reliability and lumen maintenance. The robust product design thrives in outdoor applications with high ambient temperatures and high humidity.

Part number options

Base part number

Part number	Description
LZ1-00A100-xxxx	LZ1 emitter
LZ1-10A100-xxxx	LZ1 emitter on Standard Star MCPCB
LZ1-30A100-xxxx	LZ1 emitter on Miniature round MCPCB

Bin kit option codes

A1, Amber (590nm)			
Kit number suffix	Min flux Bin	Color Bin Range	Description
0000	K	A3 – A6	full distribution flux; full distribution wavelength

Notes:

1. Default bin kit option is -0000

Luminous Flux Bins

Table 1:

Bin Code	Minimum	Maximum
	Luminous Flux (Φ_v) @ $I_F = 1000\text{mA}^{[1,2]}$ (lm)	Luminous Flux (Φ_v) @ $I_F = 1000\text{mA}^{[1,2]}$ (lm)
K	75	93
L	93	117
M	117	146

Notes for Table 1:

- Luminous flux performance guaranteed within published operating conditions. LED Engin maintains a tolerance of $\pm 10\%$ on flux measurements.
- Future products will have even higher levels of luminous flux performance. Contact LED Engin Sales for updated information.

Dominant Wavelength Bins

Table 2:

Bin Code	Minimum	Maximum
	Dominant Wavelength (λ_D) @ $I_F = 1000\text{mA}^{[1]}$ (nm)	Dominant Wavelength (λ_D) @ $I_F = 1000\text{mA}^{[1]}$ (nm)
A3	587.5	590.0
A4	590.0	592.5
A5	592.5	595.0
A6	595.0	597.5

Notes for Table 2:

- Dominant wavelength is derived from the CIE 1931 Chromaticity Diagram and represents the perceived hue.
- LED Engin maintains a tolerance of $\pm 1.0\text{nm}$ on dominant wavelength measurements.

Forward Voltage Bins

Table 3:

Bin Code	Minimum	Maximum
	Forward Voltage (V_F) @ $I_F = 1000\text{mA}^{[1]}$ (V)	Forward Voltage (V_F) @ $I_F = 1000\text{mA}^{[1]}$ (V)
0	2.24	2.9

Notes for Table 3:

- LED Engin maintains a tolerance of $\pm 0.04\text{V}$ for forward voltage measurements.

Absolute Maximum Ratings

Table 4:

Parameter	Symbol	Value	Unit
DC Forward Current at $T_{jmax}=100^{\circ}\text{C}^{[1]}$	I_F	1200	mA
DC Forward Current at $T_{jmax}=125^{\circ}\text{C}^{[1]}$	I_F	1000	mA
Peak Pulsed Forward Current ^[2]	I_{FP}	2000	mA
Reverse Voltage	V_R	See Note 3	V
Storage Temperature	T_{stg}	-40 ~ +125	$^{\circ}\text{C}$
Junction Temperature	T_J	125	$^{\circ}\text{C}$
Soldering Temperature ^[4]	T_{sol}	260	$^{\circ}\text{C}$
Allowable Reflow Cycles		6	
Autoclave Conditions ^[5]		121 $^{\circ}\text{C}$ at 2 ATM, 100% RH for 168 hours	
ESD Sensitivity ^[6]		> 8,000 V HBM Class 3B JESD22-A114-D	

Notes for Table 4:

- Maximum DC forward current is determined by the overall thermal resistance and ambient temperature. Follow the curves in Figure 10 for current derating.
- Pulse forward current conditions: Pulse Width $\leq 10\text{msec}$ and Duty Cycle $\leq 10\%$.
- LEDs are not designed to be reverse biased.
- Solder conditions per JEDEC 020D. See Reflow Soldering Profile Figure 3.
- Autoclave Conditions per JEDEC JESD22-A102-C.
- LED Engin recommends taking reasonable precautions towards possible ESD damages and handling the LZ1-00A100 in an electrostatic protected area (EPA). An EPA may be adequately protected by ESD controls as outlined in ANSI/ESD S6.1.

Optical Characteristics @ $T_C = 25^{\circ}\text{C}$

Table 5:

Parameter	Symbol	Typical	Unit
Luminous Flux (@ $I_F = 1000\text{mA}$)	Φ_V	105	lm
Dominant Wavelength (@ $I_F = 1000\text{mA}$) ^[1]	λ_D	590	nm
Viewing Angle ^[2]	$2\theta_{1/2}$	76	Degrees
Total Included Angle ^[3]	$\Theta_{0.9V}$	115	Degrees

Notes for Table 5:

- Amber LEDs have a significant shift in wavelength over temperature; please refer to Figure 6 for details. Caution must be exercised if designing to meet a regulated color space due to this behavior as product may shift out of legal color space under elevated temperatures.
- Viewing Angle is the off axis angle from emitter centerline where the luminous intensity is $\frac{1}{2}$ of the peak value.
- Total Included Angle is the total angle that includes 90% of the total luminous flux.

Electrical Characteristics @ $T_C = 25^{\circ}\text{C}$

Table 6:

Parameter	Symbol	Typical	Unit
Forward Voltage (@ $I_F = 1000\text{mA}$)	V_F	2.6	V
Forward Voltage (@ $I_F = 1200\text{mA}$)	V_F	2.7	V
Temperature Coefficient of Forward Voltage	$\Delta V_F / \Delta T_J$	-1.9	mV/ $^{\circ}\text{C}$
Thermal Resistance (Junction to Case)	$R\theta_{J-C}$	10	$^{\circ}\text{C}/\text{W}$

IPC/JEDEC Moisture Sensitivity Level

Table 7 - IPC/JEDEC J-STD-20D.1 MSL Classification:

Level	Floor Life		Soak Requirements			
	Time	Conditions	Standard	Accelerated	Time (hrs)	Conditions
1	Unlimited	≤ 30°C/ 85% RH	168 +5/-0	85°C/ 85% RH	n/a	n/a

Notes for Table 7:

1. The standard soak time includes a default value of 24 hours for semiconductor manufacturer's exposure time (MET) between bake and bag and includes the maximum time allowed out of the bag at the distributor's facility.

Average Lumen Maintenance Projections

Lumen maintenance generally describes the ability of a lamp to retain its output over time. The useful lifetime for solid state lighting devices (Power LEDs) is also defined as Lumen Maintenance, with the percentage of the original light output remaining at a defined time period.

Based on long-term WHTOL testing, LED Engin projects that the LZ Series will deliver, on average, 70% Lumen Maintenance at 65,000 hours of operation at a forward current of 1000 mA. This projection is based on constant current operation with junction temperature maintained at or below 110°C.

Mechanical Dimensions (mm)

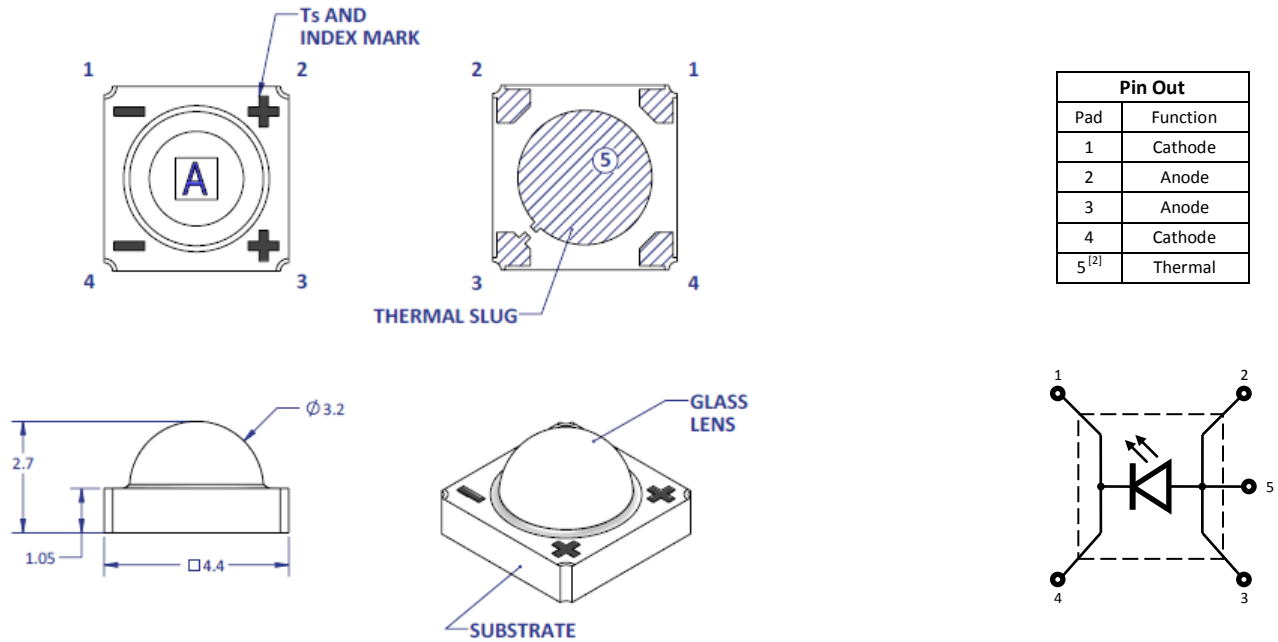

Figure 1: Package outline drawing.

Notes for Figure 1:

1. Unless otherwise noted, the tolerance = ± 0.20 mm.
2. Thermal contact, Pad 5, is electrically connected to the Anode, Pads 2 and 3. Do not electrically connect any electrical pads to the thermal contact, Pad 5. LED Engin recommends mounting the LZ1-00A100 to a MCPCB that provides insulation between all electrical pads and the thermal contact, Pad 5. LED Engin offers LZ1-10A100 and LZ1-30A100 MCPCB options which provide both electrical and thermal contact insulation with low thermal resistance. Please refer to Application Note MCPCB Options 1 and 3, or contact a LED Engin sales representative for more information.

Recommended Solder Pad Layout (mm)

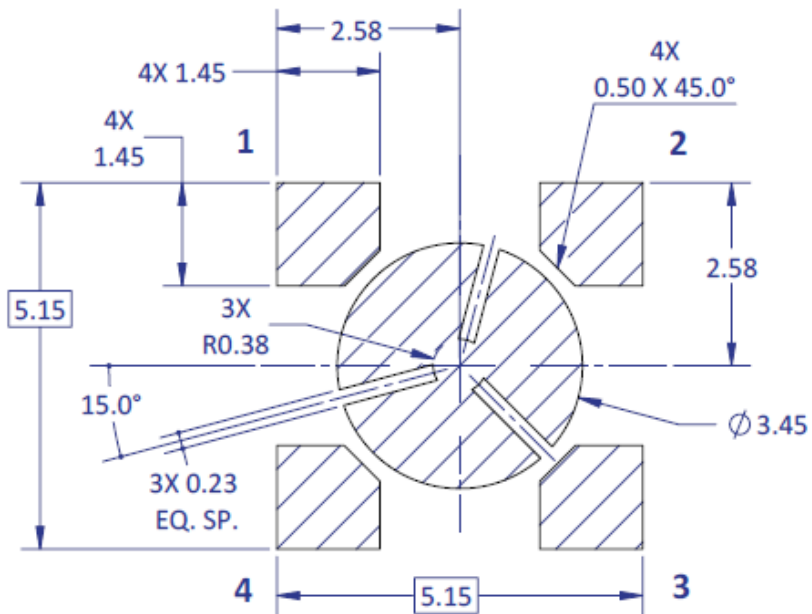

Figure 2a: Recommended solder pad layout for anode, cathode, and thermal pad

Note for Figure 2a:

1. Unless otherwise noted, the tolerance = ± 0.20 mm.

Recommended Solder Mask Layout (mm)

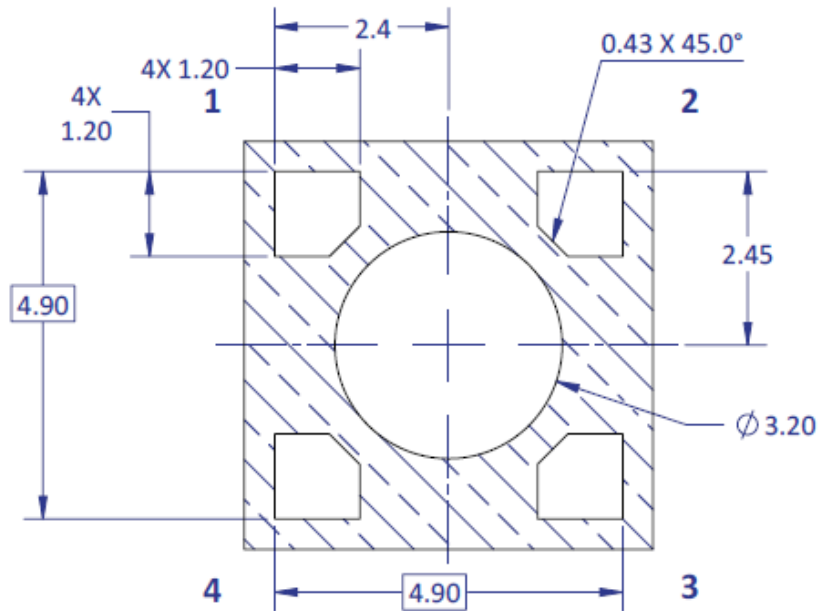

Figure 2b: Recommended solder mask opening for anode, cathode, and thermal pad

Note for Figure 2b:

1. Unless otherwise noted, the tolerance = ± 0.20 mm.

Recommended 8mil Stencil Apertures Layout (mm)

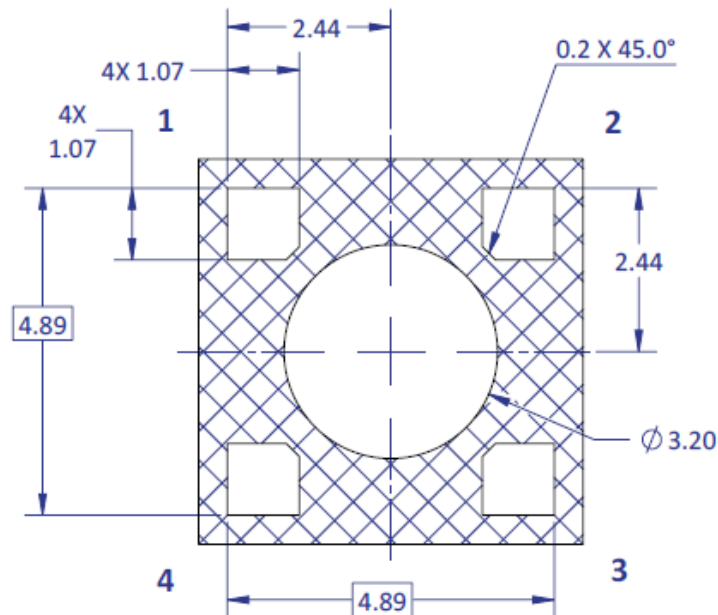

Figure 2c: Recommended 8mil stencil apertures layout for anode, cathode, and thermal pad

Note for Figure 2c:

1. Unless otherwise noted, the tolerance = ± 0.20 mm.

Reflow Soldering Profile

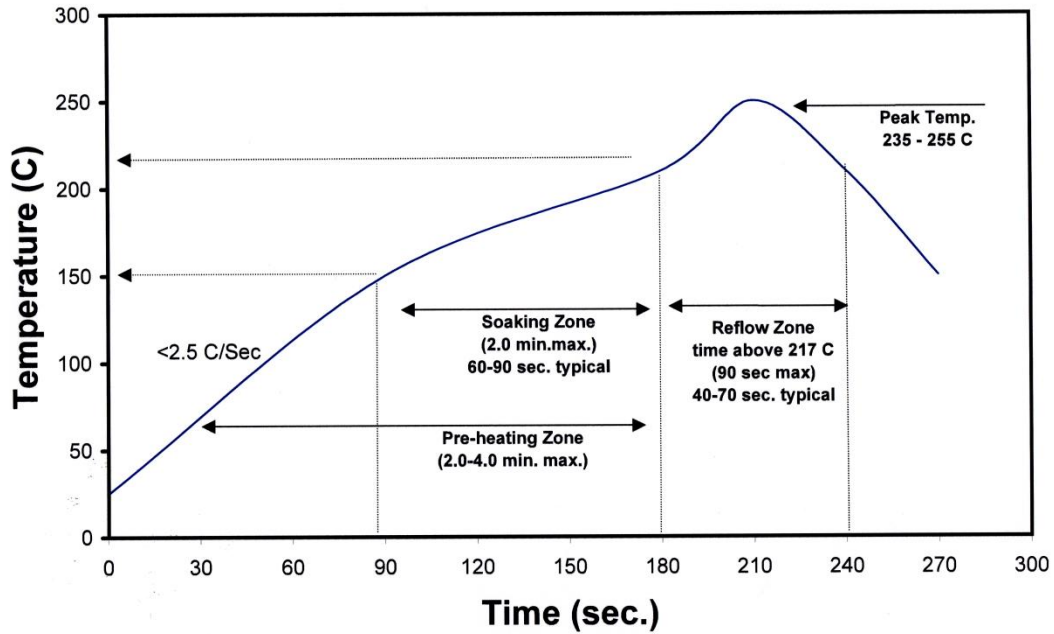

Figure 3: Reflow soldering profile for lead free soldering.

Typical Radiation Pattern

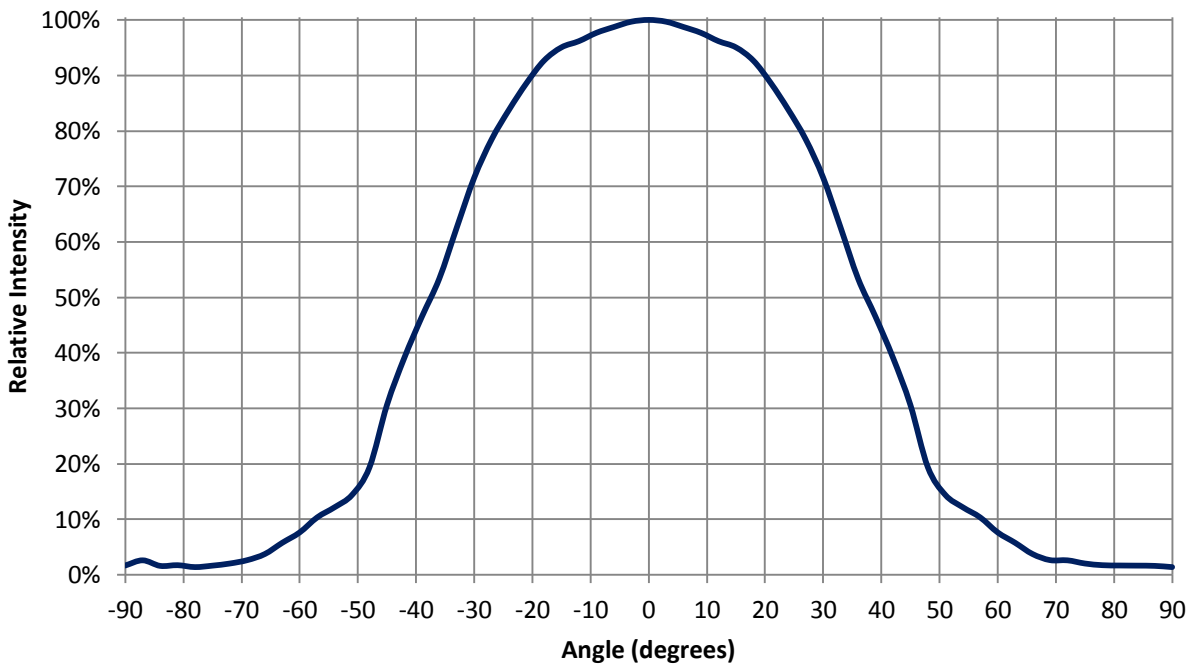

Figure 4: Typical representative spatial radiation pattern.

Typical Relative Spectral Power Distribution

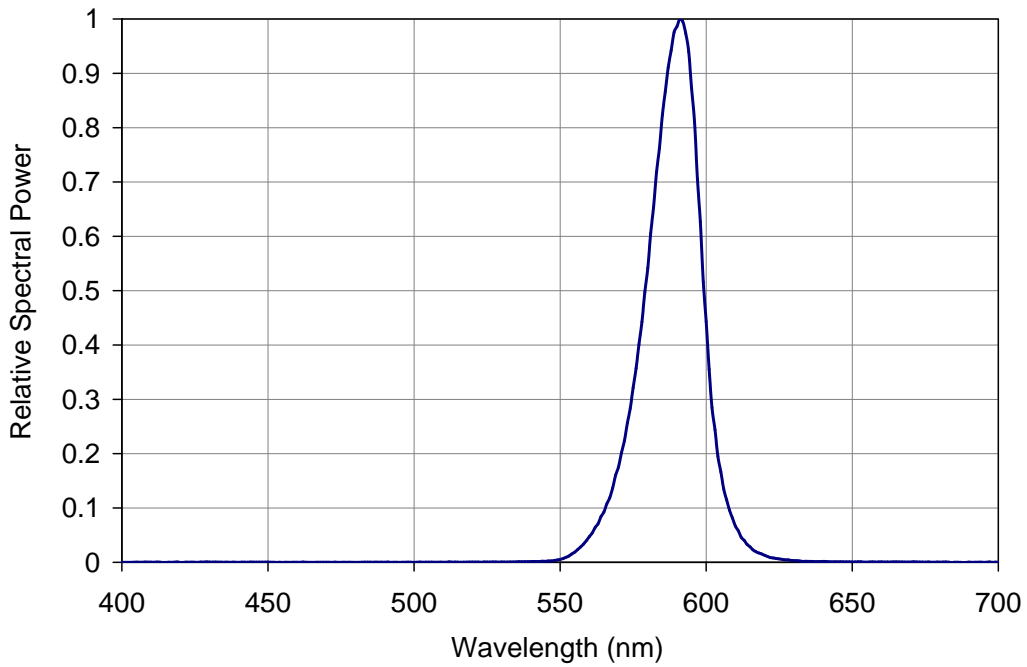

Figure 5: Relative spectral power vs. wavelength @ $T_c = 25^\circ\text{C}$.

Typical Relative Dominant Wavelength Shift over Temperature

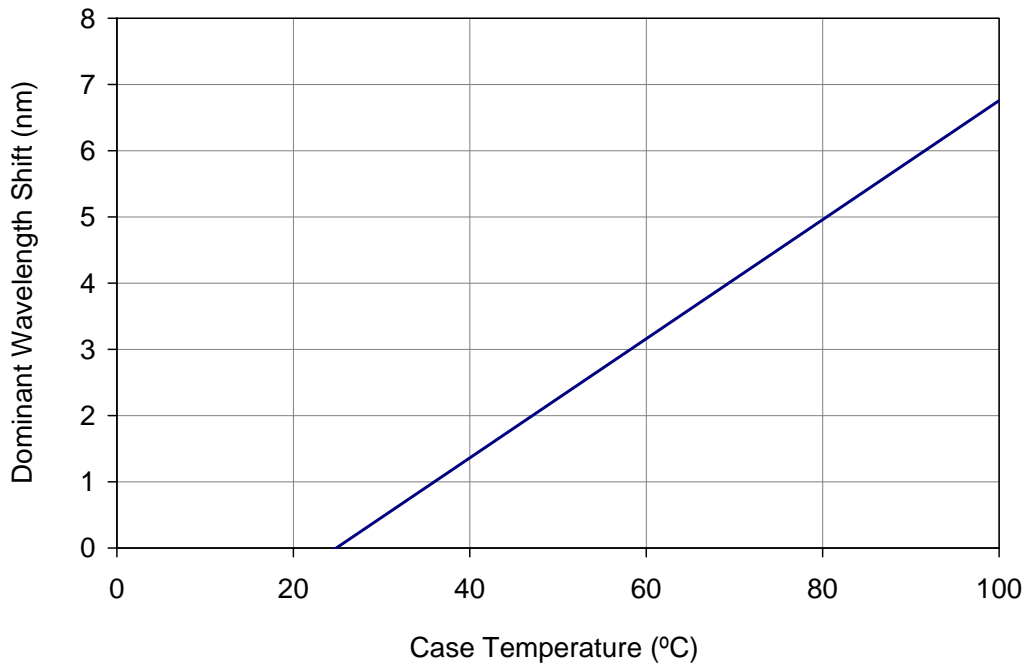

Figure 6: Typical dominant wavelength shift vs. case temperature.

Typical Relative Light Output

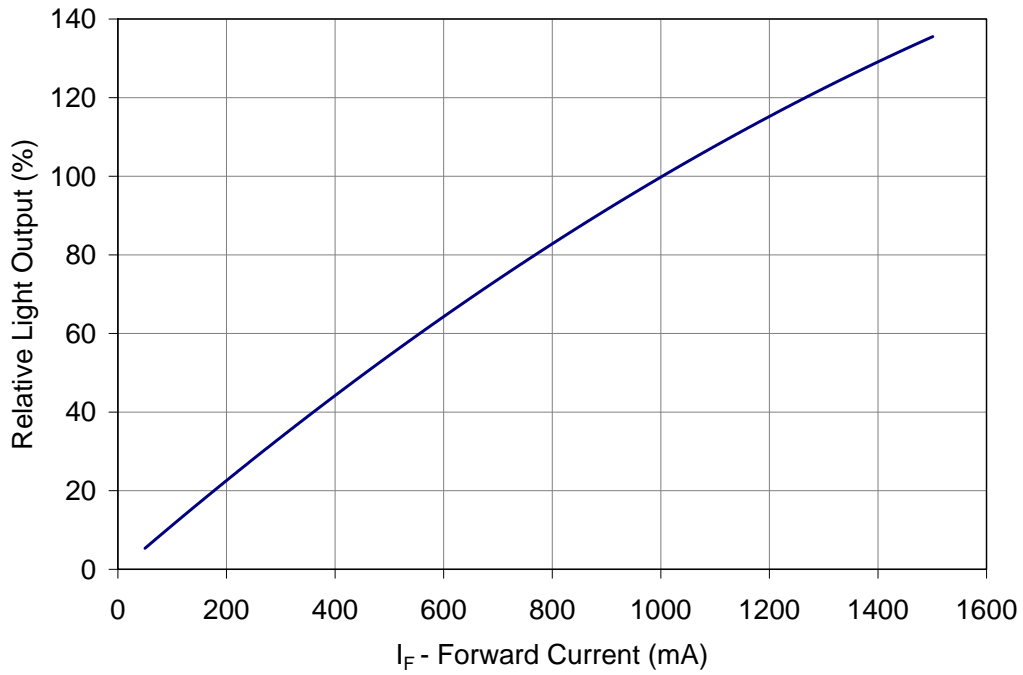

Figure 7: Typical relative light output vs. forward current @ $T_C = 25^\circ\text{C}$.

Typical Relative Light Output over Temperature

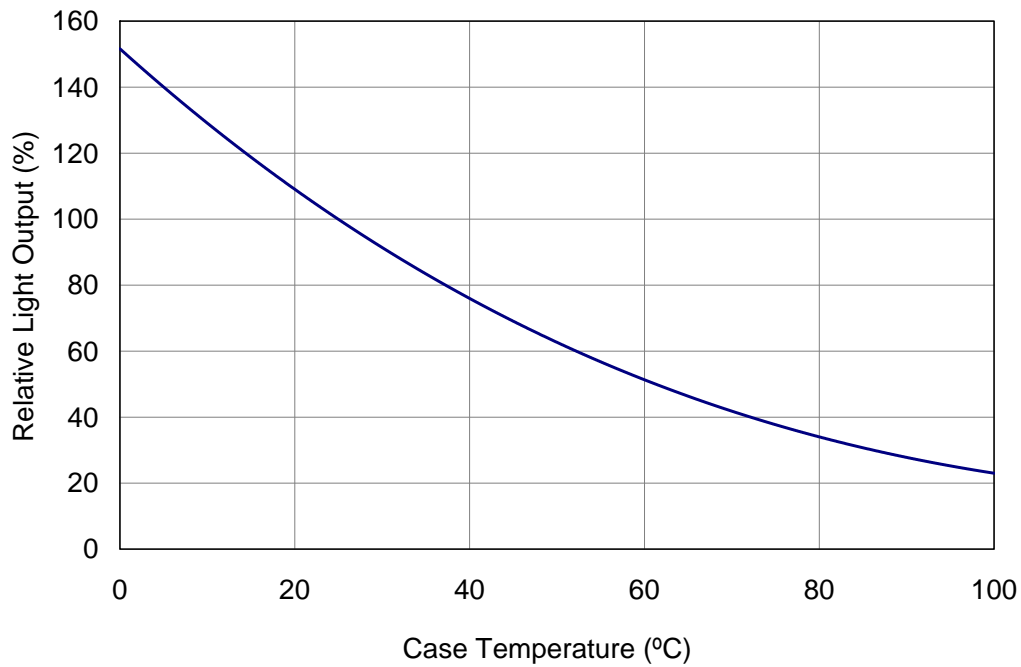

Figure 8: Typical relative light output vs. case temperature.

Typical Forward Current Characteristics

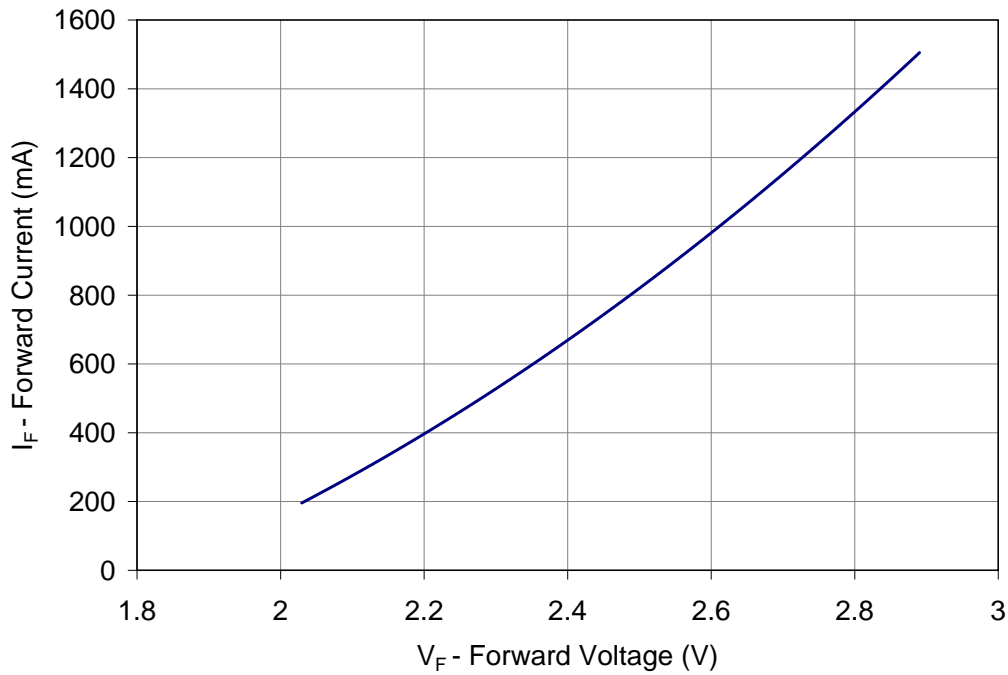

Figure 9: Typical forward current vs. forward voltage @ T_C = 25°C.

Current De-rating

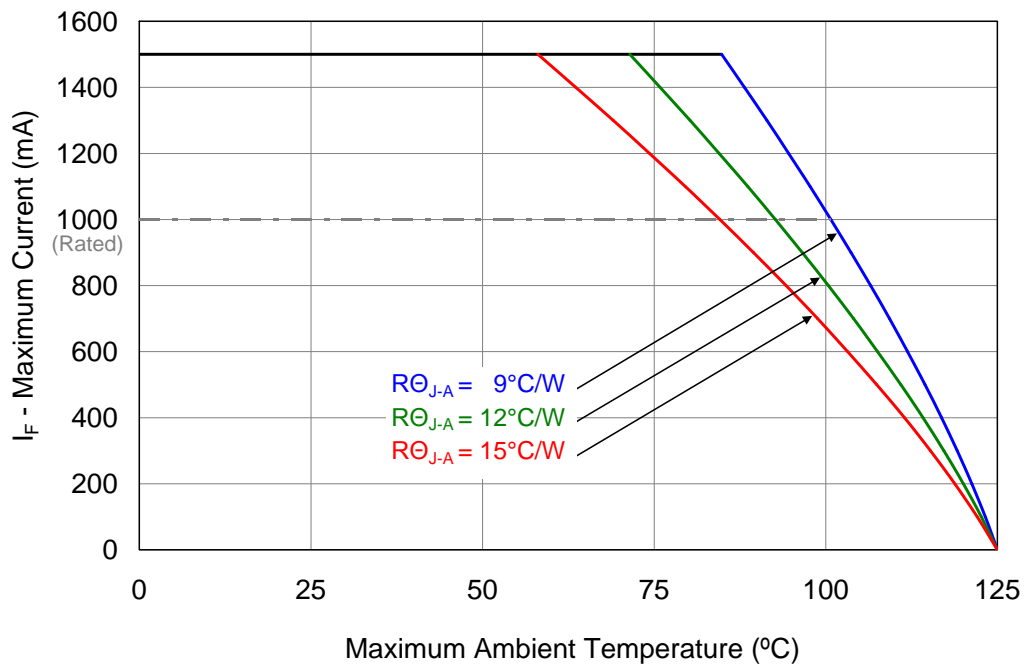

Figure 10: Maximum forward current vs. ambient temperature based on T_{J(MAX)} = 125°C.

Notes for Figure 10:

1. R_{θ_{J-C}} [Junction to Case Thermal Resistance] for the LZ1-00A100 is typically 10°C/W.
2. R_{θ_{J-A}} [Junction to Ambient Thermal Resistance] = R_{θ_{J-C}} + R_{θ_{C-A}} [Case to Ambient Thermal Resistance].

Emitter Tape and Reel Specifications (mm)

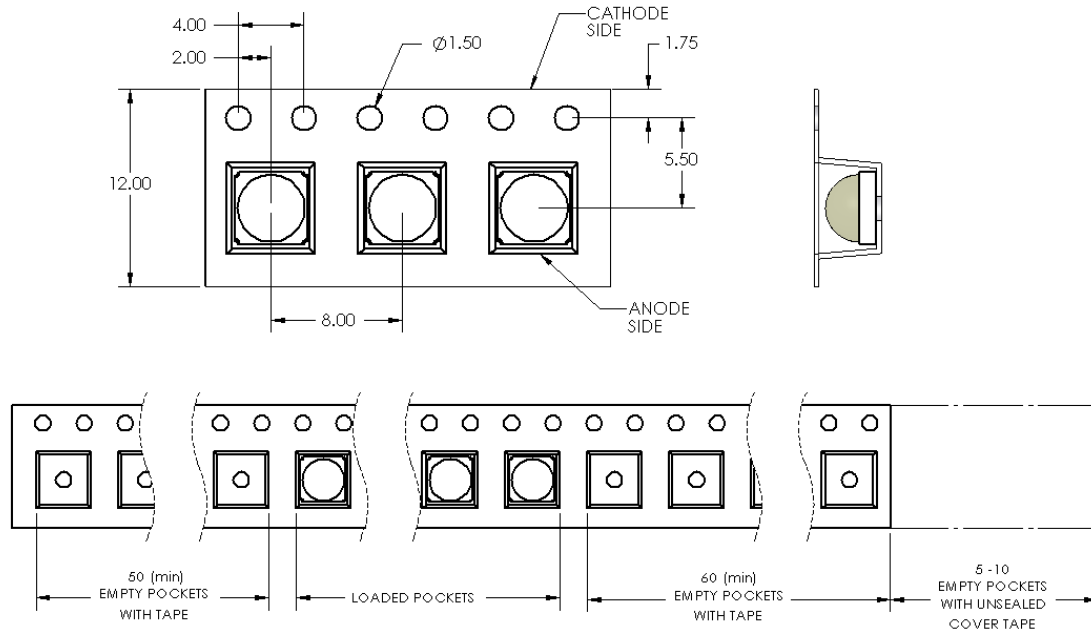

Figure 11: Emitter carrier tape specifications (mm).

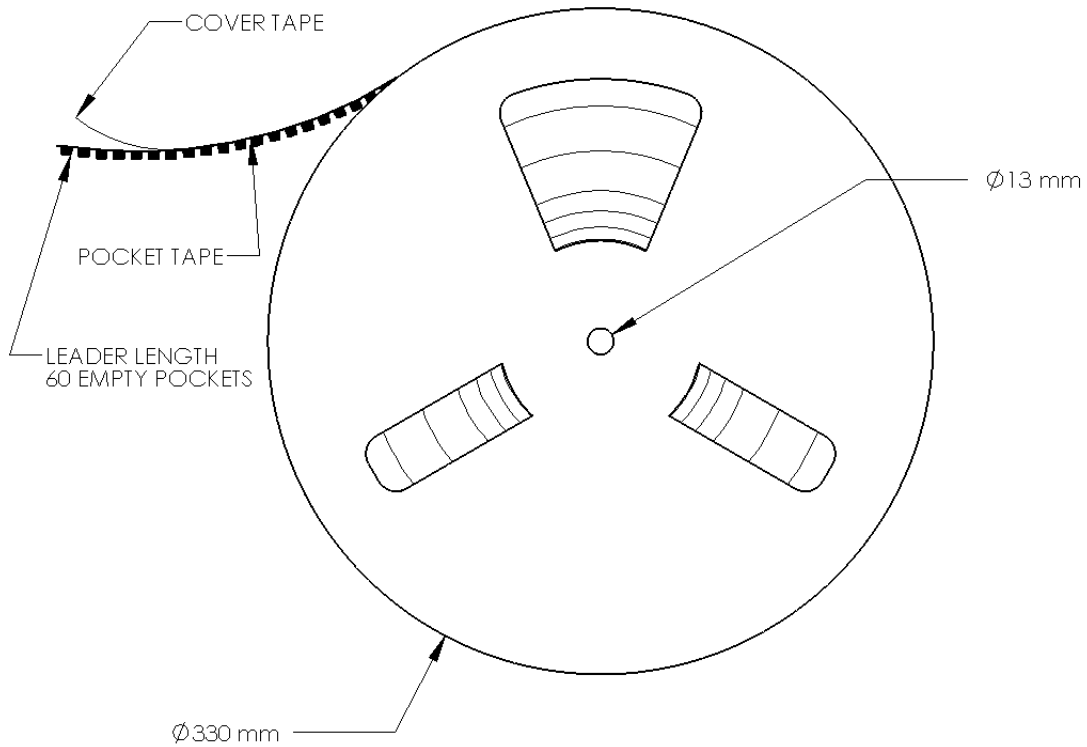

Figure 12: Emitter reel specifications (mm).

Notes for Figure 12:

1. Reel quantity minimum: 200 emitters. Reel quantity maximum: 2500 emitters.

LZ1 MCPCB Family

Part number	Type of MCPCB	Diameter (mm)	Emitter + MCPCB Thermal Resistance (°C/W)	Typical V_f (V)	Typical I_f (mA)
LZ1-1xxxxxx	1-channel Star	19.9	10.5 + 1.5 = 12.0	2.6	1000
LZ1-3xxxxxx	1-channel Mini	11.5	10.5 + 2.0 = 12.5	2.6	1000

Mechanical Mounting of MCPCB

- MCPCB bending should be avoided as it will cause mechanical stress on the emitter, which could lead to substrate cracking and subsequently LED dies cracking.
- To avoid MCPCB bending:
 - Special attention needs to be paid to the flatness of the heat sink surface and the torque on the screws.
 - Care must be taken when securing the board to the heat sink. This can be done by tightening three M3 screws (or #4-40) in steps and not all the way through at once. Using fewer than three screws will increase the likelihood of board bending.
 - It is recommended to always use plastics washers in combinations with the three screws.
 - If non-taped holes are used with self-tapping screws, it is advised to back out the screws slightly after tightening (with controlled torque) and then re-tighten the screws again.

Thermal interface material

- To properly transfer heat from LED emitter to heat sink, a thermally conductive material is required when mounting the MCPCB on to the heat sink.
- There are several varieties of such material: thermal paste, thermal pads, phase change materials and thermal epoxies. An example of such material is Electrolube EHTC.
- It is critical to verify the material's thermal resistance to be sufficient for the selected emitter and its operating conditions.

Wire soldering

- To ease soldering wire to MCPCB process, it is advised to preheat the MCPCB on a hot plate of 125-150°C. Subsequently, apply the solder and additional heat from the solder iron will initiate a good solder reflow. It is recommended to use a solder iron of more than 60W.
- It is advised to use lead-free, no-clean solder. For example: SN-96.5 AG-3.0 CU 0.5 #58/275 from Kester (pn: 24-7068-7601)

LZ1-1xxxxx

1 channel, Standard Star MCPCB (1x1) Dimensions (mm)

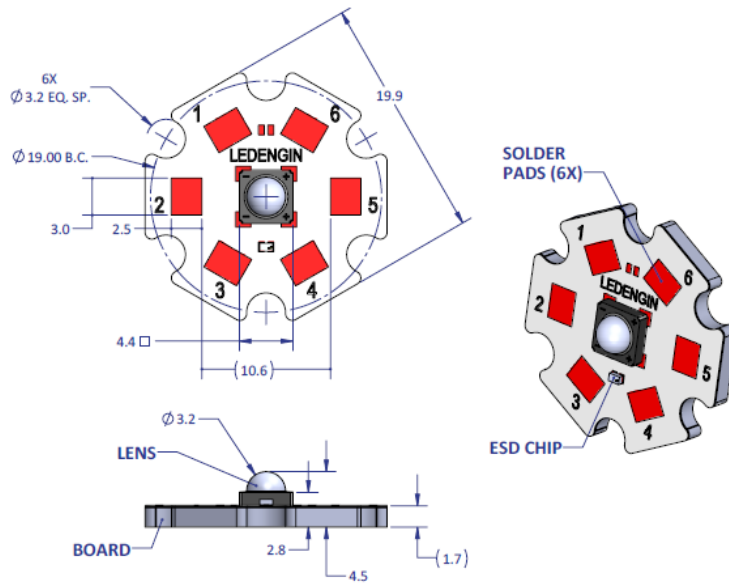

Notes:

- Unless otherwise noted, the tolerance = ± 0.2 mm.
- Slots in MCPCB are for M3 or #4-40 mounting screws.
- LED Engin recommends plastic washers to electrically insulate screws from solder pads and electrical traces.
- Electrical connection pads on MCPCB are labeled “+” for Anode and “-” for Cathode.
- LED Engin recommends using thermal interface material when attaching the MCPCB to a heat sink.
- The thermal resistance of the MCPCB is: $R_{\theta C-B} 1.5^{\circ}\text{C}/\text{W}$

Components used

MCPCB:	HT04503	(Bergquist)
ESD/TVS Diode:	BZT52C5V1LP-7	(Diodes, Inc., for 1 LED die)
	VBUS05L1-DD1	(Vishay Semiconductors, for 1 LED die)

Pad layout			
Ch.	MCPCB Pad	String/die	Function
1	1,2,3	1/A	Cathode -
	4,5,6		Anode +

LZ1-3xxxxx

1 channel, Mini Round MCPCB (1x1) Dimensions (mm)

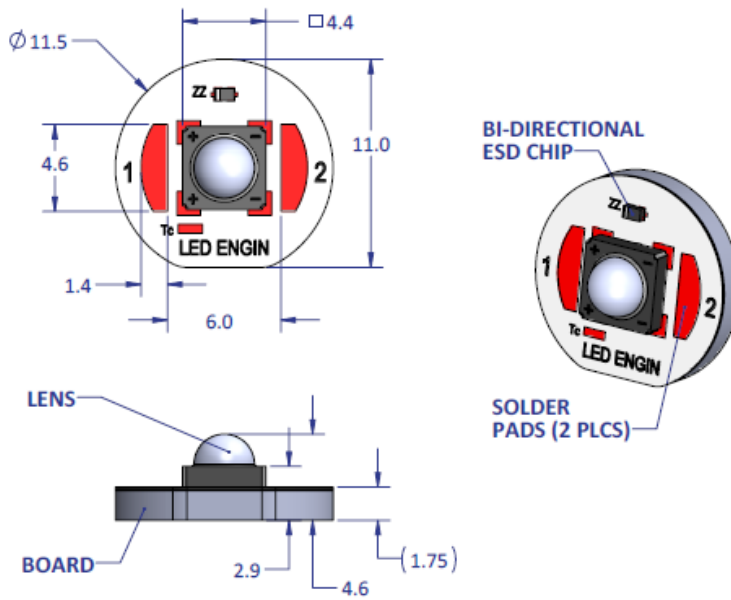

Notes:

- Unless otherwise noted, the tolerance = ± 0.20 mm.
- Electrical connection pads on MCPCB are labeled "+" for Anode and "-" for Cathode.
- LED Engin recommends using thermal interface material when attaching the MCPCB to a heat sink.
- The thermal resistance of the MCPCB is: R θ C-B 2.0°C/W

Components used

MCPCB: HT04503 (Bergquist)
 ESD/TVS Diode: BZT52C5V1LP-7 (Diodes, Inc., for 1 LED die)
 VBUS05L1-DD1 (Vishay Semiconductors, for 1 LED die)

Pad layout			
Ch.	MCPCB Pad	String/die	Function
1	1	1/A	Anode +
	2		Cathode -

Company Information

LED Engin, Inc., based in California's Silicon Valley, specializes in ultra-bright, ultra compact solid state lighting solutions allowing lighting designers & engineers the freedom to create uncompromised yet energy efficient lighting experiences. The LuxiGen™ Platform — an emitter and lens combination or integrated module solution, delivers superior flexibility in light output, ranging from 3W to 90W, a wide spectrum of available colors, including whites, multi-color and UV, and the ability to deliver upwards of 5,000 high quality lumens to a target. The small size combined with powerful output allows for a previously unobtainable freedom of design wherever high-flux density, directional light is required. LED Engin's packaging technologies lead the industry with products that feature lowest thermal resistance, highest flux density and consummate reliability, enabling compact and efficient solid state lighting solutions.

LED Engin is committed to providing products that conserve natural resources and reduce greenhouse emissions.

LED Engin reserves the right to make changes to improve performance without notice.

Please contact sales@ledengin.com or (408) 922-7200 for more information.



Компания «ЭлектроПласт» предлагает заключение долгосрочных отношений при поставках импортных электронных компонентов на взаимовыгодных условиях!

Наши преимущества:

- Оперативные поставки широкого спектра электронных компонентов отечественного и импортного производства напрямую от производителей и с крупнейших мировых складов;
- Поставка более 17-ти миллионов наименований электронных компонентов;
- Поставка сложных, дефицитных, либо снятых с производства позиций;
- Оперативные сроки поставки под заказ (от 5 рабочих дней);
- Экспресс доставка в любую точку России;
- Техническая поддержка проекта, помощь в подборе аналогов, поставка прототипов;
- Система менеджмента качества сертифицирована по Международному стандарту ISO 9001;
- Лицензия ФСБ на осуществление работ с использованием сведений, составляющих государственную тайну;
- Поставка специализированных компонентов (Xilinx, Altera, Analog Devices, Intersil, Interpoint, Microsemi, Aeroflex, Peregrine, Syfer, Eurofarad, Texas Instrument, Miteq, Cobham, E2V, MA-COM, Hittite, Mini-Circuits, General Dynamics и др.);

Помимо этого, одним из направлений компании «ЭлектроПласт» является направление «Источники питания». Мы предлагаем Вам помощь Конструкторского отдела:

- Подбор оптимального решения, техническое обоснование при выборе компонента;
- Подбор аналогов;
- Консультации по применению компонента;
- Поставка образцов и прототипов;
- Техническая поддержка проекта;
- Защита от снятия компонента с производства.



Как с нами связаться

Телефон: 8 (812) 309 58 32 (многоканальный)

Факс: 8 (812) 320-02-42

Электронная почта: org@eplast1.ru

Адрес: 198099, г. Санкт-Петербург, ул. Калинина, дом 2, корпус 4, литера А.