

## Analog Microphone with Low Power Mode

### GENERAL DESCRIPTION

The ICS-40212 is an analog MEMS microphone with very high dynamic range and a low-power AlwaysOn mode. The ICS-40212 includes a MEMS microphone element, an impedance converter, and an output amplifier.

This microphone features a low-power mode, which is active when the supply voltage is <math><2.0V</math>. In this mode, the ICS-40212 operates with 55  $\mu A</math>.$

Other high-performance specifications include 128 dB SPL acoustic overload point in high performance mode, tight  $\pm 1</math> dB sensitivity tolerance.$

The ICS-40212 is available in a small 3.50 mm  $\times$  2.65 mm  $\times$  0.98 mm bottom port surface-mount package.

### FUNCTIONAL BLOCK DIAGRAM

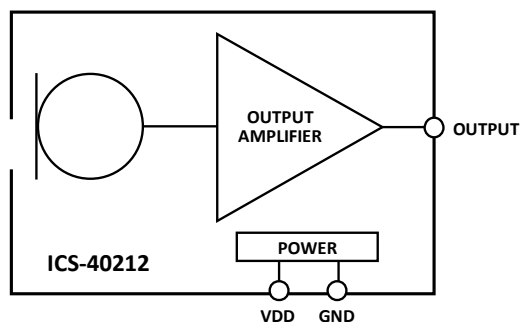

### APPLICATIONS

- Smartphones
- “AlwaysOn” listening
- Wearable devices
- Still and video cameras
- IoT devices

### FEATURES

SPEC	HIGH PERFORMANCE MODE	LOW-POWER MODE
SNR	66 dBA	66 dBA
Current	165 $\mu A$	55 $\mu A$
AOP	128 dB SPL	123 dB SPL

- Analog output
- $-38</math> dBV sensitivity$
- $\pm 1</math> dB sensitivity tolerance$
- Extended frequency response from 35 Hz to 20 kHz
- $-84</math> dB PSRR$
- 3.50  $\times$  2.65  $\times$  0.98 mm surface-mount package
- Compatible with Sn/Pb and Pb-free solder processes
- RoHS/WEEE compliant

### ORDERING INFORMATION

PART	TEMP RANGE	PACKAGING
ICS-40212	$-40^{\circ}C$ to $+85^{\circ}C$	13” Tape and Reel
EV_IC3-40212-FX	—	

**TABLE OF CONTENTS**

	General Description .....	1
	Functional Block Diagram .....	1
	Applications .....	1
	Features .....	1
	Ordering Information.....	1
1	Specifications .....	3
	1.1 Table 1. Electrical Characteristics.....	3
2	Absolute Maximum Ratings .....	5
	2.1 Table 2. Absolute Maximum Ratings.....	5
	2.2 ESD Caution .....	5
	2.3 Soldering Profile .....	6
	2.4 Table 3. Recommended Soldering Profile .....	6
3	Pin Configurations And Function Descriptions .....	7
	3.1 Table 4. Pin Function Descriptions .....	7
4	Typical Performance Characteristics.....	8
5	Theory Of Operation .....	9
	5.1 Low-Power Mode .....	9
6	Applications Information .....	10
	6.1 Codec Connection .....	10
7	Supporting Documents .....	11
	7.1 Evaluation Board User Guide .....	11
	7.2 Application Notes.....	11
8	PCB Design And Land Pattern Layout .....	12
	8.1 PCB Material And Thickness.....	12
9	Handling Instructions.....	13
	9.1 Pick And Place Equipment.....	13
	9.2 Reflow Solder .....	13
	9.3 Board Wash.....	13
10	Outline Dimensions.....	14
	10.1 Ordering Guide.....	14
	10.2 Revision History.....	15
11	Compliance Declaration Disclaimer .....	16

# 1 SPECIFICATIONS

## 1.1 TABLE 1. ELECTRICAL CHARACTERISTICS

T<sub>A</sub> = 25°C, V<sub>DD</sub> = 1.52 to 3.63 V, unless otherwise noted. Typical specifications are not guaranteed.

PARAMETER	CONDITIONS	MIN	TYP	MAX	UNITS	NOTES
<b>PERFORMANCE</b>						
Directionality		Omni				
Output Polarity		Inverted				
Sensitivity	1 kHz, 94 dB SPL	-39	-38	-37	dBV	
<b>HIGH PERFORMANCE MODE</b>						
Signal-to-Noise Ratio (SNR)	20 kHz bandwidth, A-weighted		66		dB	
Equivalent Input Noise (EIN)	20 kHz bandwidth, A-weighted		28		dB	
Dynamic Range	Derived from EIN and acoustic overload point		100		dB	
Total Harmonic Distortion (THD)	105 dB SPL		0.2	1	%	
Power Supply Rejection Ratio (PSRR)	1 kHz, 100 mV p-p sine wave superimposed on V <sub>DD</sub> = 2.75V		-84		dB	
Power Supply Rejection (PSR)	217 Hz, 100 mVp-p square wave superimposed on V <sub>DD</sub> = 2.75V		-102		dBV	
Acoustic Overload Point	10% THD		128		dB SPL	
<b>LOW-POWER MODE</b>						
Signal-to-Noise Ratio (SNR)	20 kHz bandwidth, A-weighted		66		dB	
Equivalent Input Noise (EIN)	20 kHz bandwidth, A-weighted		28		dB	
Dynamic Range	Derived from EIN and acoustic overload point		95		dB	
Total Harmonic Distortion (THD)	105 dB SPL		0.2	1	%	
Power Supply Rejection Ratio (PSRR)	1 kHz, 100 mV p-p sine wave superimposed on V <sub>DD</sub> = 1.8V		-75		dB	
Power Supply Rejection (PSR)	217 Hz, 100 mVp-p square wave superimposed on V <sub>DD</sub> = 1.8V		-96		dBV	
Acoustic Overload Point	10% THD, V <sub>DD</sub> = 1.8 V		123		dB SPL	
<b>POWER SUPPLY</b>						
Supply Voltage (V <sub>DD</sub> )	Low-power mode	1.52		2.0	V	
	High performance mode	2.2		3.63	V	
Supply Current (I <sub>S</sub> )	V <sub>DD</sub> = 1.8V		55	65	μA	
	V <sub>DD</sub> = 2.75V		165	190	μA	

PARAMETER	CONDITIONS	MIN	TYP	MAX	UNITS	NOTES
<b>OUTPUT CHARACTERISTICS</b>						
Output Impedance	High-performance mode		190		$\Omega$	
	Low-power mode		2.90		k $\Omega$	
Output Common Mode Voltage	High-performance mode		1.0		V	
	Low-power mode		0.8		V	
Startup Time	Output to within $\pm 0.5$ dB of stable sensitivity		15	20	ms	
Mode Switching Time	High performance mode to low-power mode			1	ms	
	Low-power mode to high performance mode			1	ms	
Maximum Output Voltage	128 dB SPL input		0.631		V rms	
Noise Floor	20 Hz to 20 kHz, A-weighted, rms, high performance mode		-104		dBV	

## 2 ABSOLUTE MAXIMUM RATINGS

Stress above those listed as Absolute Maximum Ratings may cause permanent damage to the device. These are stress ratings only and functional operation of the device at these conditions is not implied. Exposure to the absolute maximum ratings conditions for extended periods may affect device reliability.

### 2.1 TABLE 2. ABSOLUTE MAXIMUM RATINGS

PARAMETER	RATING
Supply Voltage (V <sub>DD</sub> )	-0.3V to +3.63V
Sound Pressure Level	160 dB
Mechanical Shock	10,000g
Vibration	Per MIL-STD-883 Method 2007, Test Condition B
Temperature Range	
Biased	-40°C to +85°C
Storage	-55°C to +150°C

### 2.2 ESD CAUTION



ESD (electrostatic discharge) sensitive device. Charged devices and circuit boards can discharge without detection. Although this product features patented or proprietary protection circuitry, damage may occur on devices subjected to high energy ESD. Therefore proper ESD precautions should be taken to avoid performance degradation or loss of functionality.

**2.3 SOLDERING PROFILE**

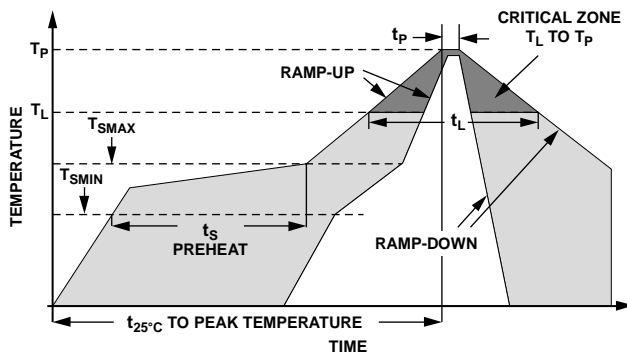

**Figure 1. Recommended Soldering Profile Limits**

**2.4 TABLE 3. RECOMMENDED SOLDERING PROFILE**

PROFILE FEATURE		SN63/PB37	PB-FREE
Average Ramp Rate ( $T_L$ to $T_P$ )		1.25°C/sec max	1.25°C/sec max
Preheat	Minimum Temperature ( $T_{SMIN}$ )	100°C	100°C
	Minimum Temperature ( $T_{SMIN}$ )	150°C	200°C
	Time ( $T_{SMIN}$ to $T_{SMAX}$ ), $t_S$	60 sec to 75 sec	60 sec to 75 sec
Ramp-Up Rate ( $T_{SMAX}$ to $T_L$ )		1.25°C/sec	1.25°C/sec
Time Maintained Above Liquidous ( $t_L$ )		45 sec to 75 sec	~50 sec
Liquidous Temperature ( $T_L$ )		183°C	217°C
Peak Temperature ( $T_P$ )		215°C +3°C/-3°C	260°C +0°C/-5°C
Time Within +5°C of Actual Peak Temperature ( $t_P$ )		20 sec to 30 sec	20 sec to 30 sec
Ramp-Down Rate		3°C/sec max	3°C/sec max
Time +25°C ( $t_{25^\circ\text{C}}$ ) to Peak Temperature		5 min max	5 min max

**Note:** The reflow profile in Table 3 is recommended for board manufacturing with InvenSense MEMS microphones. All microphones are also compatible with the J-STD-020 profile.

### 3 PIN CONFIGURATIONS AND FUNCTION DESCRIPTIONS

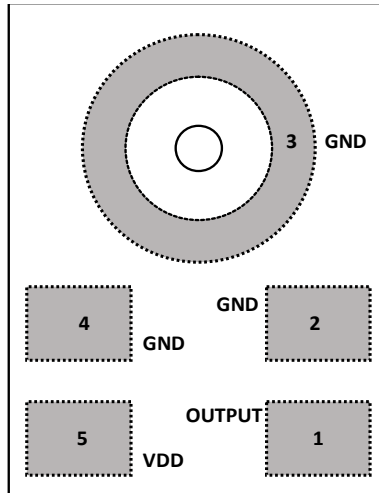
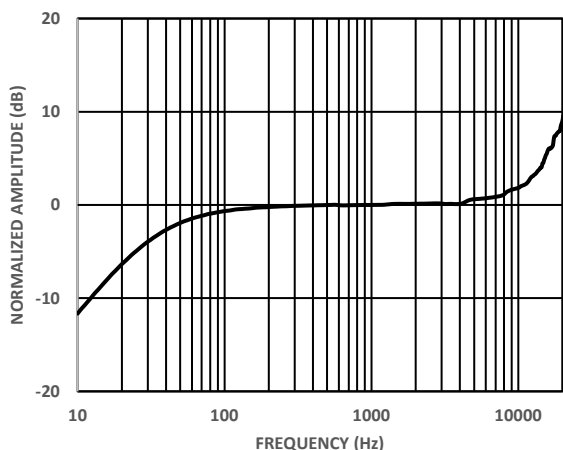

Figure 2. Pin Configuration (Top View, Terminal Side Down)

#### 3.1 TABLE 4. PIN FUNCTION DESCRIPTIONS

PIN	NAME	FUNCTION
1	OUTPUT	Analog Output Signal
2	GND	Ground
3	GND	Ground
4	GND	Ground
5	VDD	Power Supply

**4 TYPICAL PERFORMANCE CHARACTERISTICS**



**Figure 3. Typical Frequency Response (Measured)**

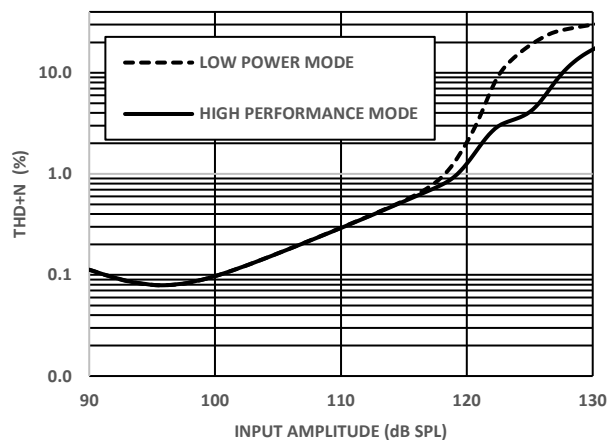

**Figure 4. THD + N vs. Input Amplitude**

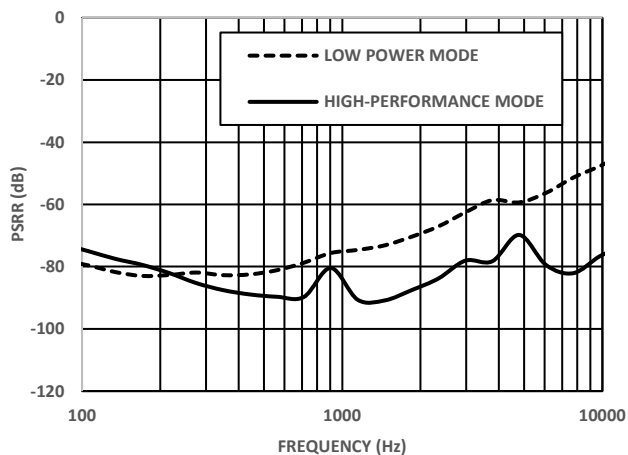

**Figure 5. Power-Supply Rejection Ratio (PSRR) vs. Frequency**

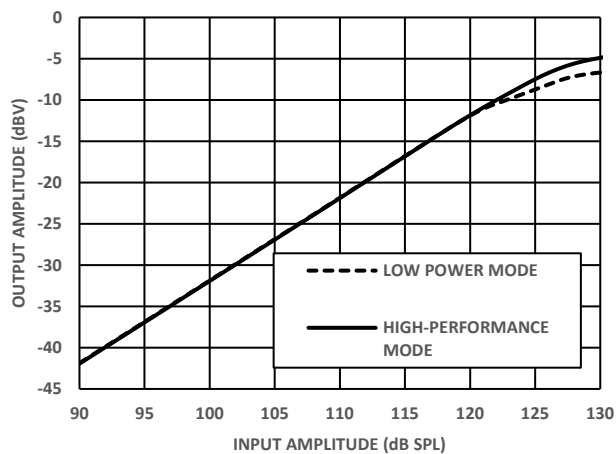

**Figure 6. Linearity**



## **5 THEORY OF OPERATION**

### **5.1 LOW-POWER MODE**

The ICS-40212 will enter a low-power mode when the supply voltage  $V_{DD}$  falls below 2.0 V. In this mode, the microphone will operate with 55  $\mu$ A supply current. While the microphone is switched between the two modes, the output signals should be muted for a short time.

## 6 APPLICATIONS INFORMATION

### 6.1 CODEC CONNECTION

The ICS-40212 output can be connected to a dedicated codec microphone input (see Figure 7) or to a high input impedance gain stage. A 0.1  $\mu\text{F}$  ceramic capacitor placed close to the ICS-40212 supply pin is used for testing and is recommended to adequately decouple the microphone from noise on the power supply. A dc blocking capacitor is required at the output of the microphone. This capacitor creates a high-pass filter with a corner frequency at

$$f_c = 1/(2\pi \times C \times R)$$

where R is the input impedance of the codec.

A minimum value of 2.2  $\mu\text{F}$  is recommended in Figure 7 for codecs, which may have a very low input impedance at some PGA gain settings.

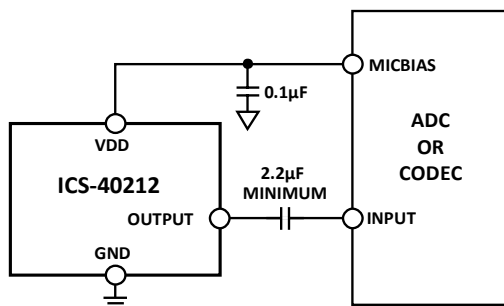

Figure 7. ICS-40212 Connected to a Codec

## **7 SUPPORTING DOCUMENTS**

For additional information, see the following documents.

### **7.1 EVALUATION BOARD USER GUIDE**

AN-000013, *Analog Output MEMS Microphone Flex Evaluation Board*

### **7.2 APPLICATION NOTES**

AN-100, *MEMS Microphone Handling and Assembly Guide*

AN-1003, *Recommendations for Mounting and Connecting the InvenSense Bottom-Ported MEMS Microphones*

AN-1112, *Microphone Specifications Explained*

AN-1124, *Recommendations for Sealing InvenSense Bottom-Port MEMS Microphones from Dust and Liquid Ingress*

AN-1140, *Microphone Array Beamforming*

AN-1165, *Op Amps for Microphone Preamp Circuits*

AN-1181, *Using a MEMS Microphone in a 2-Wire Microphone Circuit*

AN-000056, *MEMS Microphones for Active Noise Cancellation Applications*

## 8 PCB DESIGN AND LAND PATTERN LAYOUT

Lay out the PCB land pattern for the ICS-40212 at a 1:1 ratio to the solder pads on the microphone package (see Figure 8.) Avoid applying solder paste to the sound hole in the PCB. Figure 9 shows a suggested solder paste stencil pattern layout.

The response of the ICS-40212 is not affected by the PCB hole size, as long as the hole is not smaller than the sound port of the microphone (0.325 mm in diameter). A 0.5 mm to 1 mm diameter for the hole is recommended.

Align the hole in the microphone package with the hole in the PCB. The exact degree of the alignment does not affect the performance of the microphone as long as the holes are not partially or completely blocked.

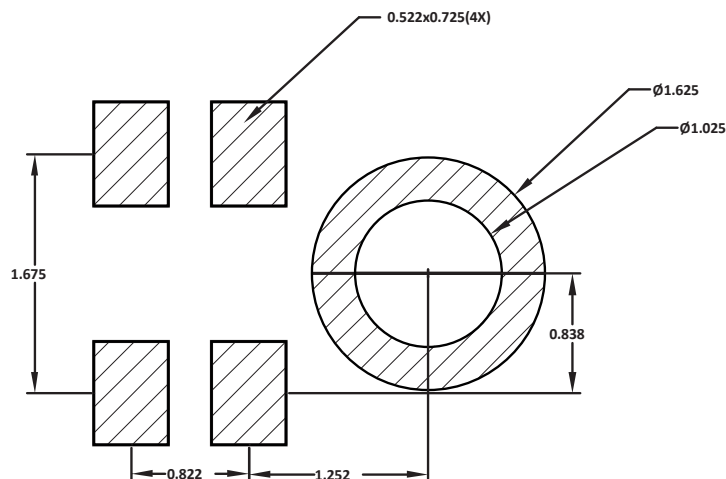

Figure 8. Recommended PCB Land Pattern Layout

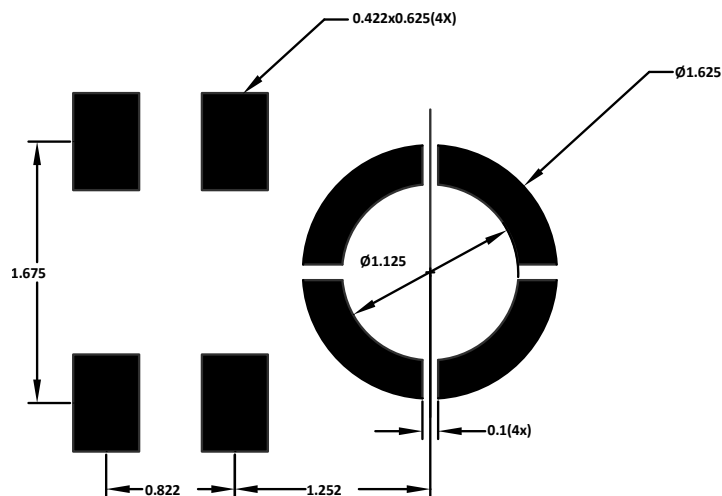

Figure 9. Recommended Solder Paste Stencil Pattern Layout

### 8.1 PCB MATERIAL AND THICKNESS

The performance of the ICS-40212 is not affected by PCB thickness. The ICS-40212 can be mounted on either a rigid or flexible PCB. A flexible PCB with the microphone can be attached directly to the device housing with an adhesive layer. This mounting method offers a reliable seal around the sound port while providing the shortest acoustic path for good sound quality.

## **9 HANDLING INSTRUCTIONS**

### **9.1 PICK AND PLACE EQUIPMENT**

The MEMS microphone can be handled using standard pick-and-place and chip shooting equipment. Take care to avoid damage to the MEMS microphone structure as follows:

- Use a standard pickup tool to handle the microphone. Because the microphone hole is on the bottom of the package, the pickup tool can make contact with any part of the lid surface.
- Do not pick up the microphone with a vacuum tool that makes contact with the bottom side of the microphone. Do not pull air out of or blow air into the microphone port.
- Do not use excessive force to place the microphone on the PCB.

### **9.2 REFLOW SOLDER**

For best results, the soldering profile must be in accordance with the recommendations of the manufacturer of the solder paste used to attach the MEMS microphone to the PCB. It is recommended that the solder reflow profile not exceed the limit conditions specified in Figure 1 and Table 3.

### **9.3 BOARD WASH**

When washing the PCB, ensure that water does not make contact with the microphone port. Do not use blow-off procedures or ultrasonic cleaning.

## 10 OUTLINE DIMENSIONS

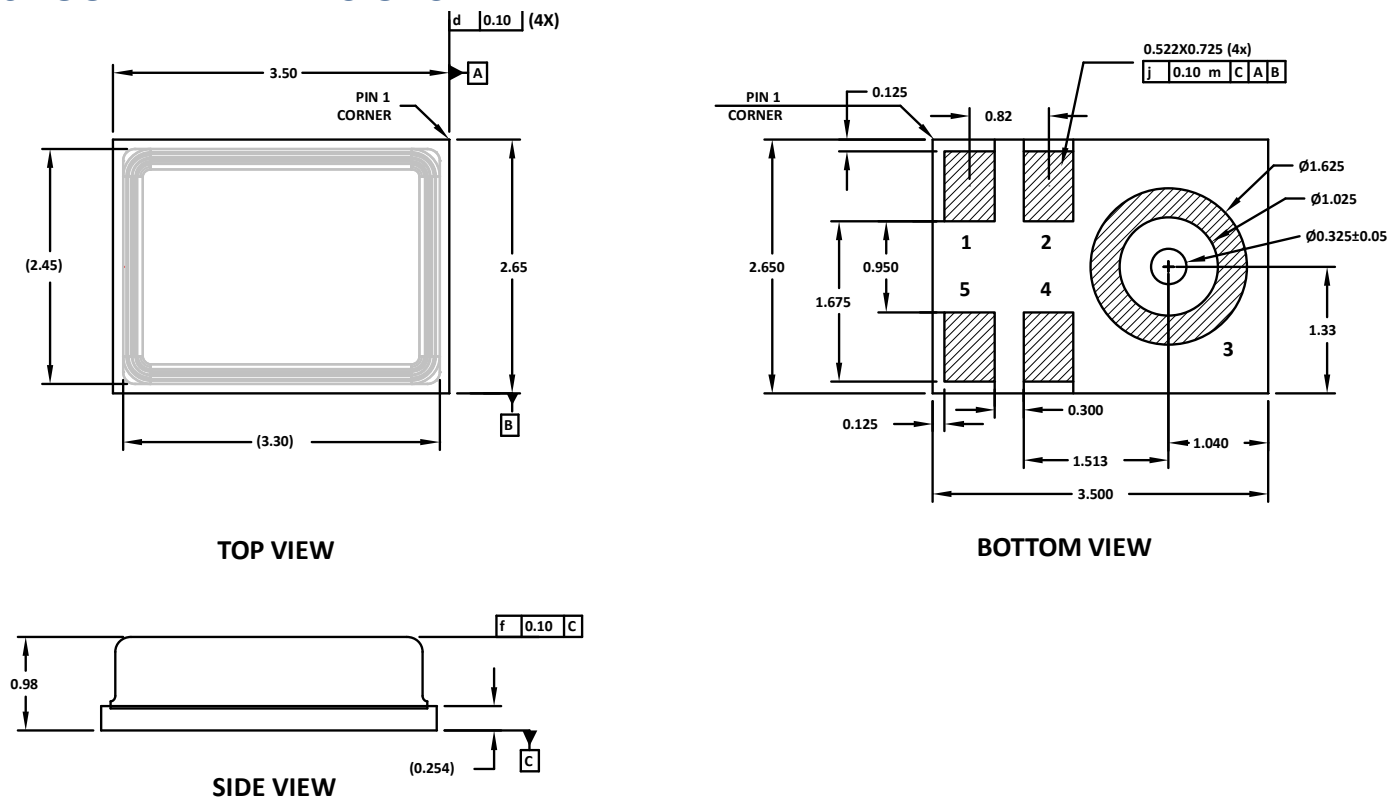

Figure 10. 5-Terminal Chip Array Small Outline No Lead Cavity  
3.50 mm × 2.65 mm × 0.98 mm Body  
Dimensions shown in millimeters

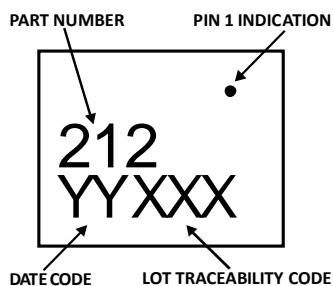

Figure 11. Package Marking Specification (Top View, not to scale)

### 10.1 ORDERING GUIDE

PART	TEMP RANGE	PACKAGE	QUANTITY	PACKAGING
ICS-40212	-40°C to +85°C	5-Terminal LGA_CAV	10,000	13" Tape and Reel
EV_IC3-40212-FX	—	Flexible Evaluation Board	—	

**10.2 REVISION HISTORY**

REVISION DATE	REVISION	DESCRIPTION
2/16/2017	1.0	Initial Version
7/05/2017	1.1	Updated Setion 2 and 4

## **11 COMPLIANCE DECLARATION DISCLAIMER**

InvenSense believes the environmental and other compliance information given in this document to be correct but cannot guarantee accuracy or completeness. Conformity documents substantiating the specifications and component characteristics are on file. InvenSense subcontracts manufacturing, and the information contained herein is based on data received from vendors and suppliers, which has not been validated by InvenSense.

This information furnished by InvenSense, Inc. ("InvenSense") is believed to be accurate and reliable. However, no responsibility is assumed by InvenSense for its use, or for any infringements of patents or other rights of third parties that may result from its use. Specifications are subject to change without notice. InvenSense reserves the right to make changes to this product, including its circuits and software, in order to improve its design and/or performance, without prior notice. InvenSense makes no warranties, neither expressed nor implied, regarding the information and specifications contained in this document. InvenSense assumes no responsibility for any claims or damages arising from information contained in this document, or from the use of products and services detailed therein. This includes, but is not limited to, claims or damages based on the infringement of patents, copyrights, mask work and/or other intellectual property rights.

Certain intellectual property owned by InvenSense and described in this document is patent protected. No license is granted by implication or otherwise under any patent or patent rights of InvenSense. This publication supersedes and replaces all information previously supplied. Trademarks that are registered trademarks are the property of their respective companies. InvenSense sensors should not be used or sold in the development, storage, production or utilization of any conventional or mass-destructive weapons or for any other weapons or life threatening applications, as well as in any other life critical applications such as medical equipment, transportation, aerospace and nuclear instruments, undersea equipment, power plant equipment, disaster prevention and crime prevention equipment.

©2017 InvenSense. All rights reserved. InvenSense, MotionTracking, MotionProcessing, MotionProcessor, MotionFusion, MotionApps, DMP, AAR, and the InvenSense logo are trademarks of InvenSense, Inc.



©2017 InvenSense. All rights reserved.





Компания «ЭлектроПласт» предлагает заключение долгосрочных отношений при поставках импортных электронных компонентов на взаимовыгодных условиях!

Наши преимущества:

- Оперативные поставки широкого спектра электронных компонентов отечественного и импортного производства напрямую от производителей и с крупнейших мировых складов;
- Поставка более 17-ти миллионов наименований электронных компонентов;
- Поставка сложных, дефицитных, либо снятых с производства позиций;
- Оперативные сроки поставки под заказ (от 5 рабочих дней);
- Экспресс доставка в любую точку России;
- Техническая поддержка проекта, помощь в подборе аналогов, поставка прототипов;
- Система менеджмента качества сертифицирована по Международному стандарту ISO 9001;
- Лицензия ФСБ на осуществление работ с использованием сведений, составляющих государственную тайну;
- Поставка специализированных компонентов (Xilinx, Altera, Analog Devices, Intersil, Interpoint, Microsemi, Aeroflex, Peregrine, Syfer, Eurofarad, Texas Instrument, Miteq, Cobham, E2V, MA-COM, Hittite, Mini-Circuits, General Dynamics и др.);

Помимо этого, одним из направлений компании «ЭлектроПласт» является направление «Источники питания». Мы предлагаем Вам помощь Конструкторского отдела:

- Подбор оптимального решения, техническое обоснование при выборе компонента;
- Подбор аналогов;
- Консультации по применению компонента;
- Поставка образцов и прототипов;
- Техническая поддержка проекта;
- Защита от снятия компонента с производства.



#### Как с нами связаться

**Телефон:** 8 (812) 309 58 32 (многоканальный)

**Факс:** 8 (812) 320-02-42

**Электронная почта:** [org@eplast1.ru](mailto:org@eplast1.ru)

**Адрес:** 198099, г. Санкт-Петербург, ул. Калинина, дом 2, корпус 4, литера А.